

# 16-Bit Rail-to-Rail Micropower DACs in SO-8 Package

## FEATURES

- 16-Bit Monotonicity Over Temperature
- Deglitched Rail-to-Rail Voltage Output
- SO-8 Package
- $I_{CC(TYP)}$ : 600 $\mu$ A
- Internal Reference: 2.048V (LTC1655)  
1.25V (LTC1655L)
- Maximum DNL Error:  $\pm 1$ LSB
- Settling Time: 20 $\mu$ s to  $\pm 1$ LSB
- 750kHz Max Update Rate
- Power-On Reset to Zero Volts
- 3-Wire Cascadable Serial Interface
- Low Cost
- Pin Compatible Upgrade for LTC1451 12-Bit DAC Family

## APPLICATIONS

- Digital Calibration
- Industrial Process Control
- Automatic Test Equipment
- Cellular Telephones

## DESCRIPTION

The LTC<sup>®</sup>1655/LTC1655L are rail-to-rail voltage output, 16-bit digital-to-analog converters in an SO-8 package. They include an output buffer and a reference. The 3-wire serial interface is compatible with SPI/QSPI and MICROWIRE<sup>™</sup> protocols. The CLK input has a Schmitt trigger that allows direct optocoupler interface.

The LTC1655 has an onboard 2.048V reference that can be overdriven to a higher voltage. The output swings from 0V to 4.096V when using the internal reference. The typical power dissipation is 3.0mW on a single 5V supply.

The LTC1655L has an onboard 1.25V reference that can be overdriven to a higher voltage. The output swings from 0V to 2.5V when using the internal reference. The typical power dissipation is 1.8mW on a single 3V supply.

The LTC1655/LTC1655L are pin compatible with Linear Technology's 12-bit  $V_{OUT}$  DAC family, allowing an easy upgrade path. They are the only buffered 16-bit DACs in an SO-8 package and they include an onboard reference for standalone performance.

LT, LTC and LT are registered trademarks of Linear Technology Corporation. MICROWIRE is a trademark of National Semiconductor Corporation.

## FUNCTIONAL BLOCK DIAGRAM

Functional Block Diagram: 16-Bit Rail-to-Rail DAC

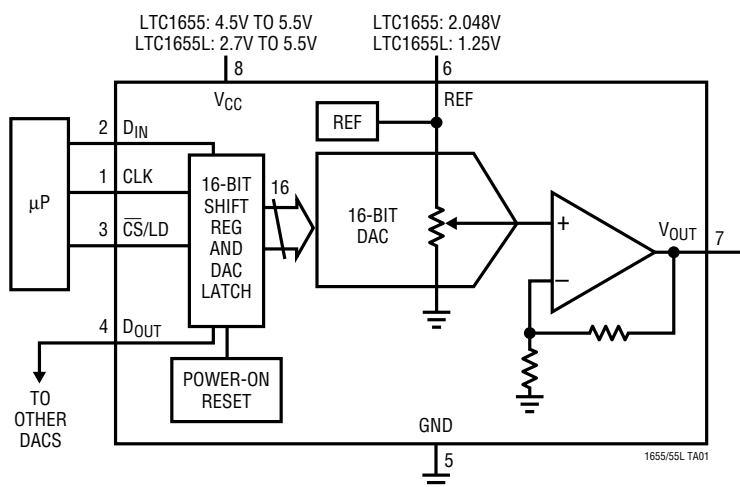

Differential Nonlinearity vs Input Code

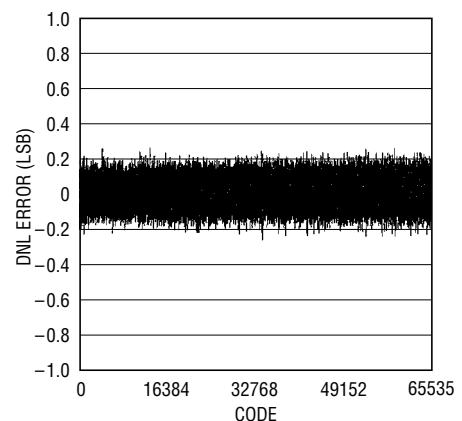

# LTC1655/LTC1655L

## ABSOLUTE MAXIMUM RATINGS

(Note 1)

$V_{CC}$ to GND .....	-0.5V to 7.5V
TTL Input Voltage .....	-0.5V to 7.5V
$V_{OUT, REF}$ .....	-0.5V to $V_{CC} + 0.5V$
Maximum Junction Temperature .....	125°C
Operating Temperature Range	
LTC1655C/LTC1655LC .....	0°C to 70°C
LTC1655I/LTC1655LI .....	-40°C to 85°C
Storage Temperature Range .....	-65°C to 150°C
Lead Temperature (Soldering, 10 sec) .....	300°C

## PACKAGE/ORDER INFORMATION

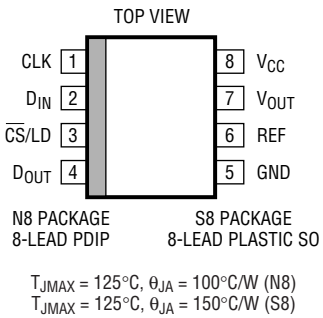
 <p>TOP VIEW</p> <p>CLK 1, DIN 2, CS/LD 3, DOUT 4, 5 GND, 6 REF, 7 VOUT, 8 VCC</p> <p>N8 PACKAGE 8-LEAD PDIP, S8 PACKAGE 8-LEAD PLASTIC SO</p> <p><math>T_{JMAX} = 125^{\circ}C, \theta_{JA} = 100^{\circ}C/W</math> (N8)  <math>T_{JMAX} = 125^{\circ}C, \theta_{JA} = 150^{\circ}C/W</math> (S8)</p>	ORDER PART NUMBER
	<p>LTC1655CN8</p> <p>LTC1655IN8</p> <p>LTC1655CS8</p> <p>LTC1655IS8</p> <p>LTC1655LCN8</p> <p>LTC1655LIN8</p> <p>LTC1655LCS8</p> <p>LTC1655LIS8</p>
	S8 PART MARKING
	<p>1655</p> <p>1655I</p> <p>1655L</p> <p>1655LI</p>

Consult factory for Military grade parts.

## ELECTRICAL CHARACTERISTICS

The ● denotes specifications which apply over the full operating temperature range, otherwise specifications are at  $T_A = 25^{\circ}C$ .  $V_{CC} = 4.5V$  to  $5.5V$  (LTC1655),  $V_{CC} = 2.7V$  to  $5.5V$  (LTC1655L);  $V_{OUT}$  unloaded, REF unloaded, unless otherwise noted.

SYMBOL	PARAMETER	CONDITIONS	MIN	TYP	MAX	UNITS
<b>DAC</b>						
	Resolution		●	16		Bits
	Monotonicity		●	16		Bits
DNL	Differential Nonlinearity	Guaranteed Monotonic (Note 2)				
		LTC1655, REF = 2.2V, $V_{CC} = 5V$ (Note 8) (External)	●	±0.3	±1.0	LSB
		LTC1655L, REF = 2.2V, $V_{CC} = 5V$ (Note 8) (External)	●	±0.5	±1.0	LSB
INL	Integral Nonlinearity	LTC1655, REF = 2.2V, $V_{CC} = 5V$ (Note 8) (External)	●	±8	±20	LSB
		LTC1655L, REF = 2.2V, $V_{CC} = 5V$ (Note 8) (External)	●	±8	±20	LSB
ZSE	Zero Scale Error	LTC1655	●	0	3.0	mV
		LTC1655L	●	0	3.5	mV
$V_{OS}$	Offset Error	Measured at Code 200				
		LTC1655, REF = 2.2V, $V_{CC} = 5V$ (Note 8) (External)	●	±0.5	±3.0	mV
		LTC1655L, REF = 1.3V, $V_{CC} = 2.7V$ (Note 8) (External)	●	±0.5	±3.5	mV
$V_{OS}TC$	Offset Error Tempco			±5		$\mu V/^{\circ}C$
	Gain Error	REF = 2.2V (External), $V_{CC} = 5V$ (Note 8)	●	±5	±16	LSB
	Gain Error Drift			0.5		ppm/ $^{\circ}C$
<b>Power Supply</b>						
$V_{CC}$	Positive Supply Voltage	For Specified Performance				
		LTC1655	●	4.5	5.5	V
		LTC1655L	●	2.7	5.5	V
$I_{CC}$	Supply Current	(Note 3)	●	600	1200	$\mu A$

## ELECTRICAL CHARACTERISTICS

The ● denotes specifications which apply over the full operating temperature range, otherwise specifications are at  $T_A = 25^\circ\text{C}$ .  $V_{CC} = 4.5\text{V}$  to  $5.5\text{V}$  (LTC1655),  $V_{CC} = 2.7\text{V}$  to  $5.5\text{V}$  (LTC1655L);  $V_{OUT}$  unloaded, REF unloaded, unless otherwise noted.

SYMBOL	PARAMETER	CONDITIONS	MIN	TYP	MAX	UNITS
<b>Op Amp DC Performance</b>						
	Short-Circuit Current Low	$V_{OUT}$ Shorted to GND LTC1655 LTC1655L	● ●	70 70	120 140	mA mA
	Short-Circuit Current High	$V_{OUT}$ Shorted to $V_{CC}$ LTC1655 LTC1655L	● ●	80 70	140 150	mA mA
	Output Impedance to GND	Input Code = 0 LTC1655 LTC1655L	● ●	40 70	120 160	$\Omega$ $\Omega$
	Output Line Regulation	Input Code = 65535, with Internal Reference			$\pm 3$	mV/V

### AC Performance

	Voltage Output Slew Rate	(Note 4)	●	$\pm 0.3$	$\pm 0.7$	V/ $\mu\text{s}$
	Voltage Output Settling Time	(Note 4) to 0.0015% (16-Bit Settling Time), $V_{CC} = 5\text{V}$ (Note 4) to 0.012% (13-Bit Settling Time), $V_{CC} = 5\text{V}$		20 10		$\mu\text{s}$ $\mu\text{s}$
	Digital Feedthrough	(Note 5)		0.3		nV-s
	Midscale Glitch Impulse	DAC Switched Between 8000 <sub>H</sub> and 7FFF <sub>H</sub>		12		nV-s
	Output Voltage Noise Spectral Density	LTC1655, At 1kHz LTC1655L, At 1kHz		280 220		nV $\sqrt{\text{Hz}}$ nV $\sqrt{\text{Hz}}$

### Reference Output

	Reference Output Voltage	LTC1655 LTC1655L	● ●	2.036 1.240	2.048 1.250	2.060 1.260	V V
	Reference Input Range	(Notes 6, 7) LTC1655 LTC1655L		2.2 1.3		$V_{CC}/2$ $V_{CC}/2$	V V
	Reference Output Tempco	LTC1655 LTC1655L			5 10		ppm/ $^\circ\text{C}$ ppm/ $^\circ\text{C}$
	Reference Input Resistance	LTC1655, REF Overdriven to 2.2V LTC1655L, REF Overdriven to 1.3V	● ●	8.5 7.0	13 13		k $\Omega$ k $\Omega$
	Reference Short-Circuit Current		●		40	100	mA
	Reference Output Line Regulation					$\pm 1.5$	mV/V
	Reference Load Regulation	$I_{OUT} = 100\mu\text{A}$	●			5	mV/A
	Reference Output Voltage Noise Spectral Density	LTC1655, At 1kHz LTC1655L, At 1kHz			150 115		nV $\sqrt{\text{Hz}}$ nV $\sqrt{\text{Hz}}$

### Digital I/O

$V_{IH}$	Digital Input High Voltage	LTC1655 LTC1655L	● ●	2.4 2.0			V V
$V_{IL}$	Digital Input Low Voltage	LTC1655 LTC1655L	● ●			0.8 0.6	V V
$V_{OH}$	Digital Output High Voltage	LTC1655, $I_{OUT} = -1\text{mA}$ LTC1655L, $I_{OUT} = -1\text{mA}$	● ●	$V_{CC} - 1.0$ $V_{CC} - 0.7$			V V
$V_{OL}$	Digital Output Low Voltage	LTC1655, $I_{OUT} = 1\text{mA}$ LTC1655L, $I_{OUT} = 1\text{mA}$	● ●			0.4 0.4	V V

## ELECTRICAL CHARACTERISTICS

The ● denotes specifications which apply over the full operating temperature range, otherwise specifications are at  $T_A = 25^\circ\text{C}$ .  $V_{CC} = 4.5\text{V}$  to  $5.5\text{V}$  (LTC1655),  $V_{CC} = 2.7\text{V}$  to  $5.5\text{V}$  (LTC1655L);  $V_{OUT}$  unloaded, REF unloaded, unless otherwise noted.

SYMBOL	PARAMETER	CONDITIONS	MIN	TYP	MAX	UNITS
$I_{LEAK}$	Digital Input Leakage	$V_{IN} = \text{GND to } V_{CC}$			$\pm 10$	$\mu\text{A}$
$C_{IN}$	Digital Input Capacitance	(Note 7)			10	pF

### Switching

$t_1$	$D_{IN}$ Valid to CLK Setup	LTC1655 LTC1655L	● ●	40 60		ns ns
$t_2$	$D_{IN}$ Valid to CLK Hold	LTC1655 LTC1655L	● ●	0 0		ns ns
$t_3$	CLK High Time	LTC1655 LTC1655L	● ●	40 60		ns ns
$t_4$	CLK Low Time	LTC1655 LTC1655L	● ●	40 60		ns ns
$t_5$	$\overline{\text{CS/LD}}$ Pulse Width	LTC1655 LTC1655L	● ●	50 80		ns ns
$t_6$	LSB CLK to $\overline{\text{CS/LD}}$	LTC1655 LTC1655L	● ●	40 60		ns ns
$t_7$	$\overline{\text{CS/LD}}$ Low to CLK	LTC1655 LTC1655L	● ●	20 30		ns ns
$t_8$	$D_{OUT}$ Output Delay	LTC1655, $C_{LOAD} = 15\text{pF}$ LTC1655L, $C_{LOAD} = 15\text{pF}$	● ●	20 20	120 300	ns ns
$t_9$	CLK Low to $\overline{\text{CS/LD}}$ Low	LTC1655 LTC1655L	● ●	20 30		ns ns

**Note 1:** Absolute Maximum Ratings are those values beyond which the life of a device may be impaired.

**Note 2:** Nonlinearity is defined from code 128 to code 65535 (full scale). See Applications Information.

**Note 3:** DAC switched between all 1s and all 0s.  $V_{FS} = 4.096\text{V}$ .

**Note 4:** Digital inputs at 0V or  $V_{CC}$ .

**Note 5:** Part is clocked with pin toggling between 1s and 0s,  $\overline{\text{CS/LD}}$  is low.

**Note 6:** Reference can be overdriven (see Applications Information).

**Note 7:** Guaranteed by design. Not subject to test.

**Note 8:** Guaranteed by correlation for other reference and supply conditions.

# TYPICAL PERFORMANCE CHARACTERISTICS

$V_{CC} = 5V$  (LTC1655),  $V_{CC} = 3V$  (LTC1655L) unless otherwise noted.

**TC1655 Differential Nonlinearity**

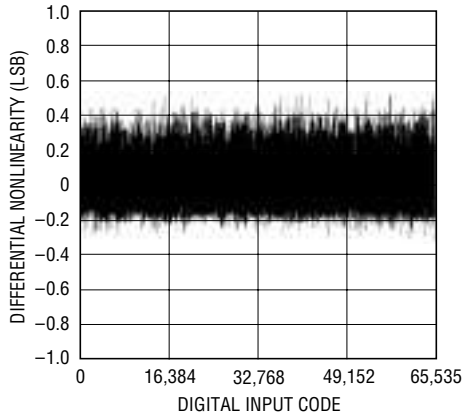

1655/55L G01

**LTC1655L Differential Nonlinearity**

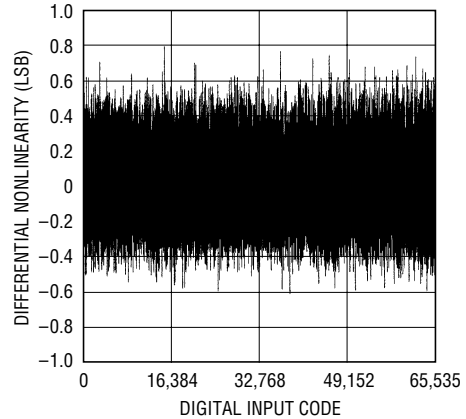

1655/55L G01a

**LTC1655 Integral Nonlinearity**

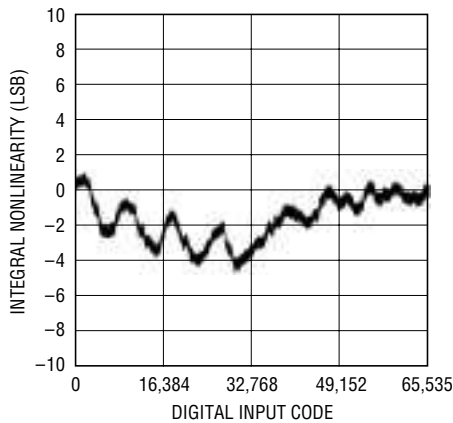

1655/55L G02

**LTC1655L Integral Nonlinearity**

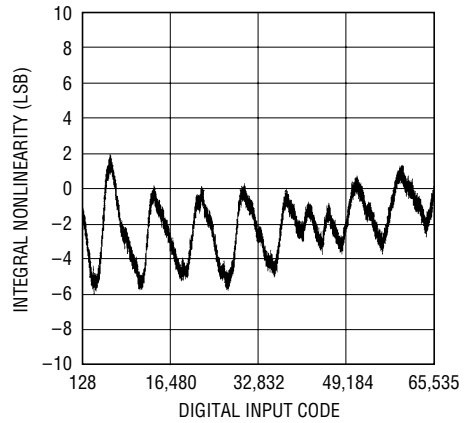

1655/55L G02a

**LTC1655 Minimum Supply Headroom for Full Output Swing vs Load Current**

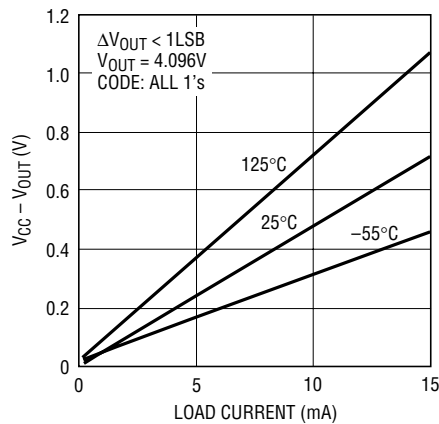

1655/55L G03

**LTC1655L Minimum Supply Headroom for Full Output Swing vs Load Current**

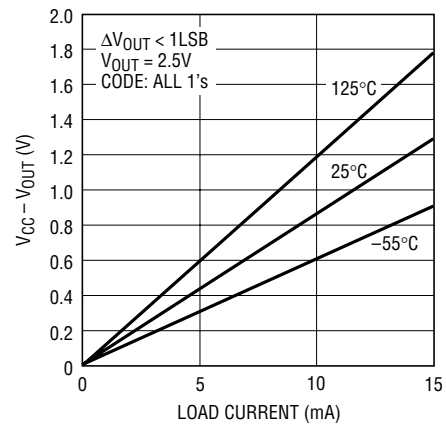

1655/55L G03a

## TYPICAL PERFORMANCE CHARACTERISTICS

$V_{CC} = 5V$  (LTC1655),  $V_{CC} = 3V$  (LTC1655L) unless otherwise noted.

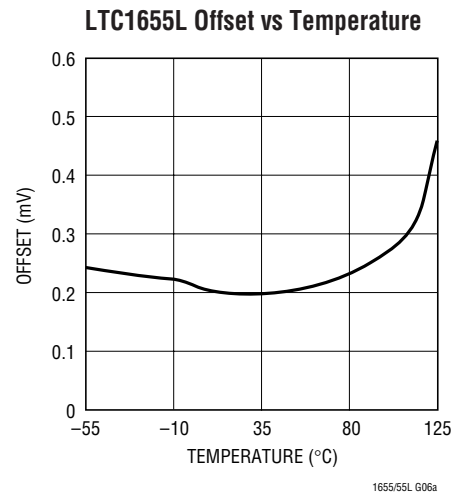
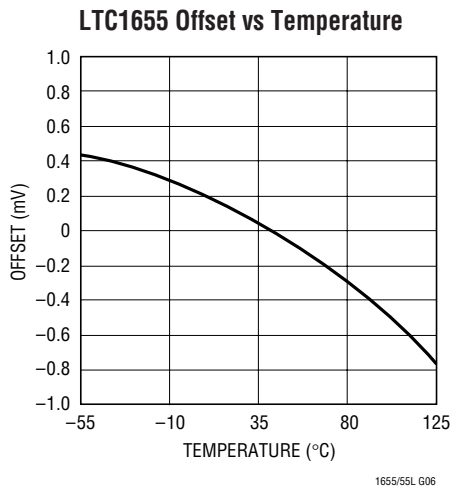
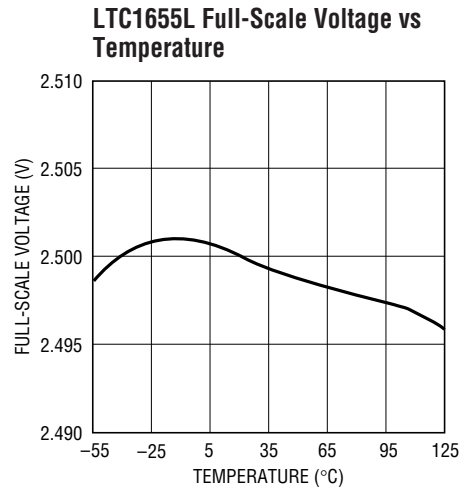
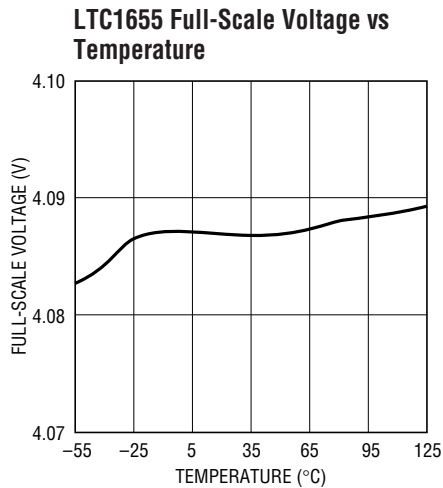
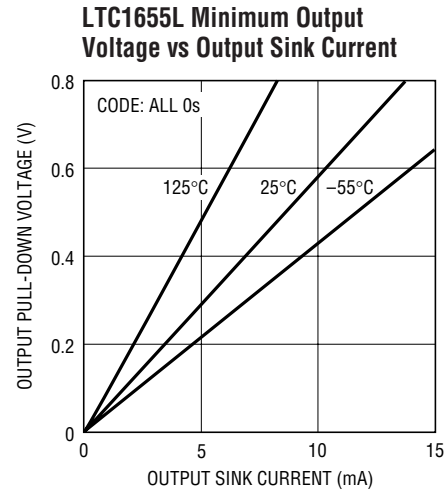
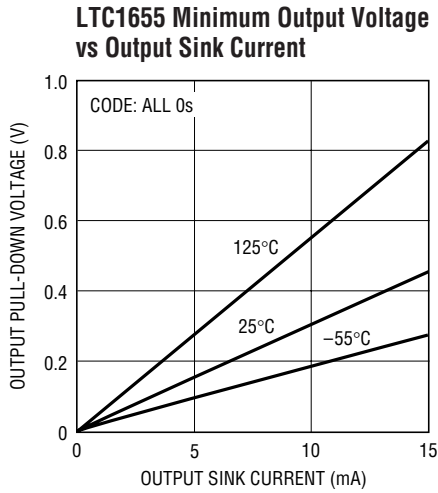

# TYPICAL PERFORMANCE CHARACTERISTICS

$V_{CC} = 5V$  (LTC1655),  $V_{CC} = 3V$  (LTC1655L) unless otherwise noted.

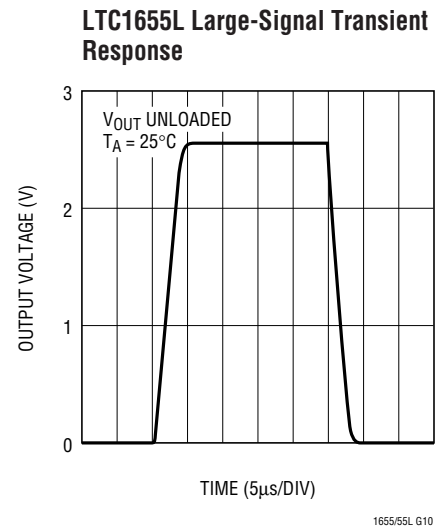
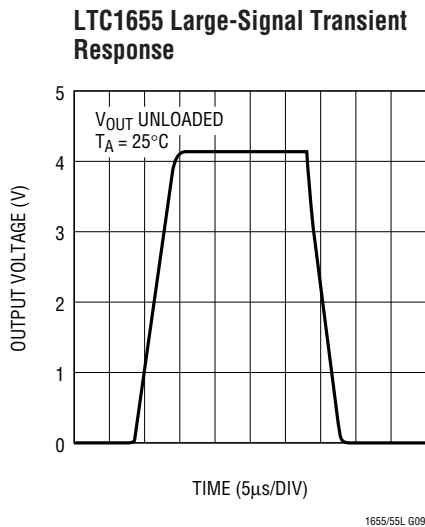
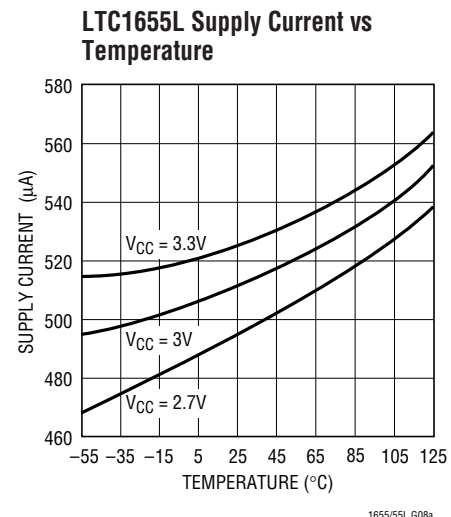
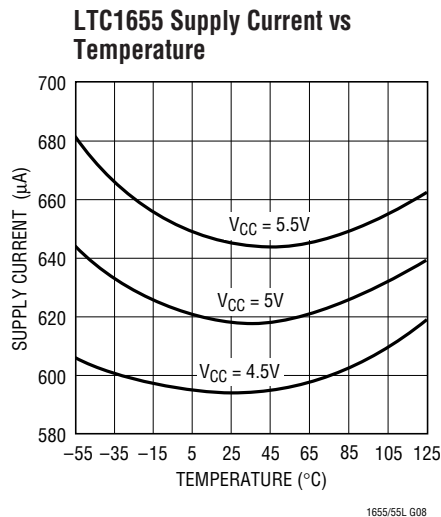
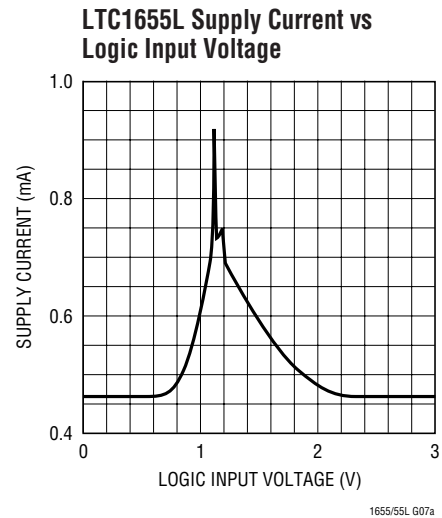
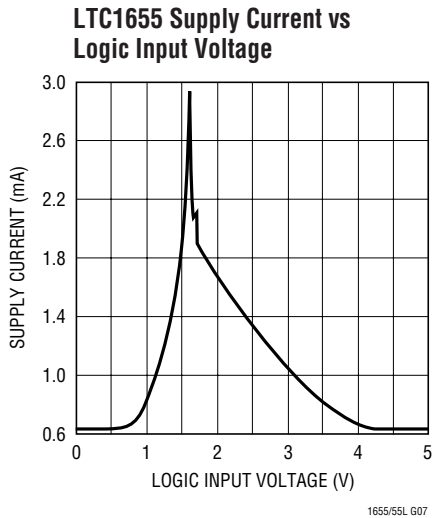

## PIN FUNCTIONS

**CLK (Pin 1):** The TTL Level Input for the Serial Interface Clock.

**D<sub>IN</sub> (Pin 2):** The TTL Level Input for the Serial Interface Data. Data on the D<sub>IN</sub> pin is latched into the shift register on the rising edge of the serial clock and is loaded MSB first. The LTC1655/LTC1655L requires a 16-bit word.

**$\overline{\text{CS/LD}}$  (Pin 3):** The TTL Level Input for the Serial Interface Enable and Load Control. When  $\overline{\text{CS/LD}}$  is low, the CLK signal is enabled, so the data can be clocked in. When  $\overline{\text{CS/LD}}$  is pulled high, data is loaded from the shift register into the DAC register, updating the DAC output.

**D<sub>OUT</sub> (Pin 4):** Output of the Shift Register. Becomes valid on the rising edge of the serial clock and swings from GND to V<sub>CC</sub>.

**GND (Pin 5):** Ground.

**REF (Pin 6):** Reference. Output of the internal reference is 2.048V (LTC1655), 1.25V (LTC1655L). There is a gain of two from this pin to the output. The reference can be overdriven from 2.2V to V<sub>CC</sub>/2 (LTC1655) and 1.3V to V<sub>CC</sub>/2 (LTC1655L). When tied to V<sub>CC</sub>/2, the output will swing from GND to V<sub>CC</sub>. The output can only swing to within its offset specification of V<sub>CC</sub> (see Applications Information).

**V<sub>OUT</sub> (Pin 7):** Deglitched Rail-to-Rail Voltage Output. V<sub>OUT</sub> clears to 0V on power-up.

**V<sub>CC</sub> (Pin 8):** Positive Supply Input. 4.5V ≤ V<sub>CC</sub> ≤ 5.5V (LTC1655), 2.7V ≤ V<sub>CC</sub> ≤ 5.5V (LTC1655L). Requires a 0.1μF bypass capacitor to ground.

## TIMING DIAGRAM

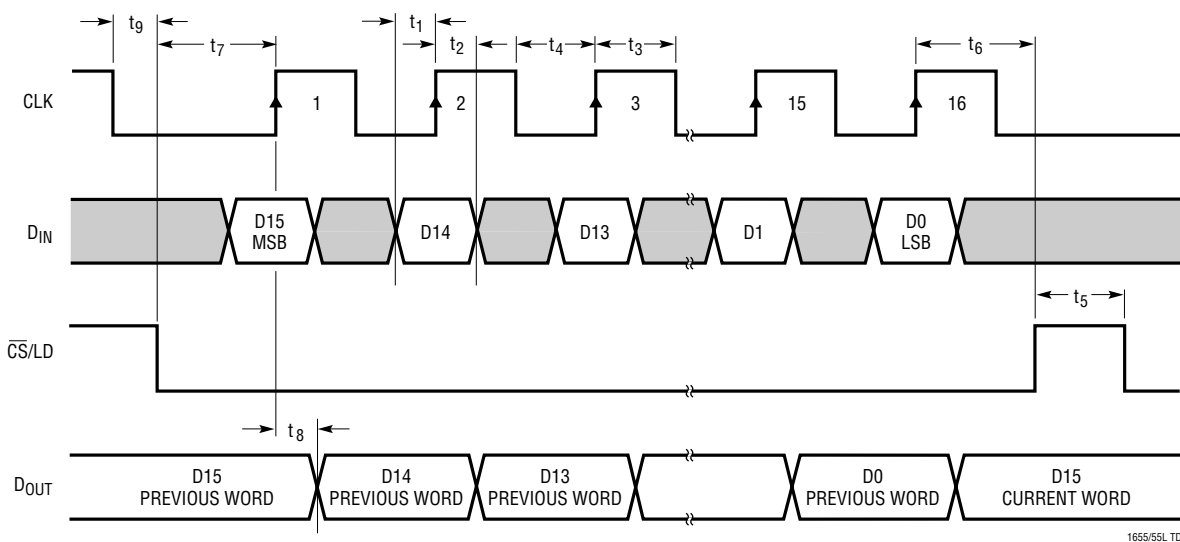

## DEFINITIONS

**Differential Nonlinearity (DNL):** The difference between the measured change and the ideal 1LSB change for any two adjacent codes. The DNL error between any two codes is calculated as follows:

$$\text{DNL} = (\Delta V_{\text{OUT}} - \text{LSB})/\text{LSB}$$

Where  $\Delta V_{\text{OUT}}$  is the measured voltage difference between two adjacent codes.

**Digital Feedthrough:** The glitch that appears at the analog output caused by AC coupling from the digital inputs when they change state. The area of the glitch is specified in (nV)(sec).

**Full-Scale Error (FSE):** The deviation of the actual full-scale voltage from ideal. FSE includes the effects of offset and gain errors (see Applications Information).

**Gain Error (GE):** The difference between the full-scale output of a DAC from its ideal full-scale value after offset error has been adjusted.

**Integral Nonlinearity (INL):** The deviation from a straight line passing through the endpoints of the DAC transfer curve (Endpoint INL). Because the output cannot go below zero, the linearity is measured between full scale and the

lowest code that guarantees the output will be greater than zero. The INL error at a given input code is calculated as follows:

$$\text{INL} = [V_{\text{OUT}} - V_{\text{OS}} - (V_{\text{FS}} - V_{\text{OS}})(\text{code}/65535)]/\text{LSB}$$

Where  $V_{\text{OUT}}$  is the output voltage of the DAC measured at the given input code.

**Least Significant Bit (LSB):** The ideal voltage difference between two successive codes.

$$\text{LSB} = 2V_{\text{REF}}/65536$$

**Resolution (n):** Defines the number of DAC output states ( $2^n$ ) that divide the full-scale range. Resolution does not imply linearity.

**Voltage Offset Error ( $V_{\text{OS}}$ ):** Nominally, the voltage at the output when the DAC is loaded with all zeros. A single supply DAC can have a true negative offset, but the output cannot go below zero (see Applications Information).

For this reason, single supply DAC offset is measured at the lowest code that guarantees the output will be greater than zero.

## OPERATION

### Serial Interface

The data on the  $D_{\text{IN}}$  input is loaded into the shift register on the rising edge of the clock. The MSB is loaded first. The DAC register loads the data from the shift register when  $\overline{\text{CS}}/\text{LD}$  is pulled high. The clock is disabled internally when  $\overline{\text{CS}}/\text{LD}$  is high. Note: CLK must be low before  $\overline{\text{CS}}/\text{LD}$  is pulled low to avoid an extra internal clock pulse. The input word must be 16 bits wide.

The buffered output of the 16-bit shift register is available on the  $D_{\text{OUT}}$  pin which swings from GND to  $V_{\text{CC}}$ .

Multiple LTC1655s/LTC1655Ls may be daisy-chained together by connecting the  $D_{\text{OUT}}$  pin to the  $D_{\text{IN}}$  pin of the next chip while the clock and  $\overline{\text{CS}}/\text{LD}$  signals remain common to all chips in the daisy chain. The serial data is clocked to all

of the chips, then the  $\overline{\text{CS}}/\text{LD}$  signal is pulled high to update all of them simultaneously. The shift register and DAC register are cleared to all 0s on power-up.

### Voltage Output

The LTC1655/LTC1655L rail-to-rail buffered output can source or sink 5mA over the entire operating temperature range while pulling to within 600mV of the positive supply voltage or ground. The output stage is equipped with a deglitcher that gives a midscale glitch of 12nV-s. At power-up, the output clears to 0V.

The output swings to within a few millivolts of either supply rail when unloaded and has an equivalent output resistance of 40 $\Omega$  (70 $\Omega$  for the LTC1655L) when driving a load to the rails. The output can drive 1000pF without going into oscillation.

## APPLICATIONS INFORMATION

### Rail-to-Rail Output Considerations

In any rail-to-rail DAC, the output swing is limited to voltages within the supply range.

If the DAC offset is negative, the output for the lowest codes limits at 0V as shown in Figure 1b.

Similarly, limiting can occur near full-scale when the REF pin is tied to  $V_{CC}/2$ . If  $V_{REF} = V_{CC}/2$  and the DAC full-scale

error (FSE) is positive, the output for the highest codes limits at  $V_{CC}$  as shown in Figure 1c. No full-scale limiting can occur if  $V_{REF}$  is less than  $(V_{CC} - FSE)/2$ .

Offset and linearity are defined and tested over the region of the DAC transfer function where no output limiting can occur.

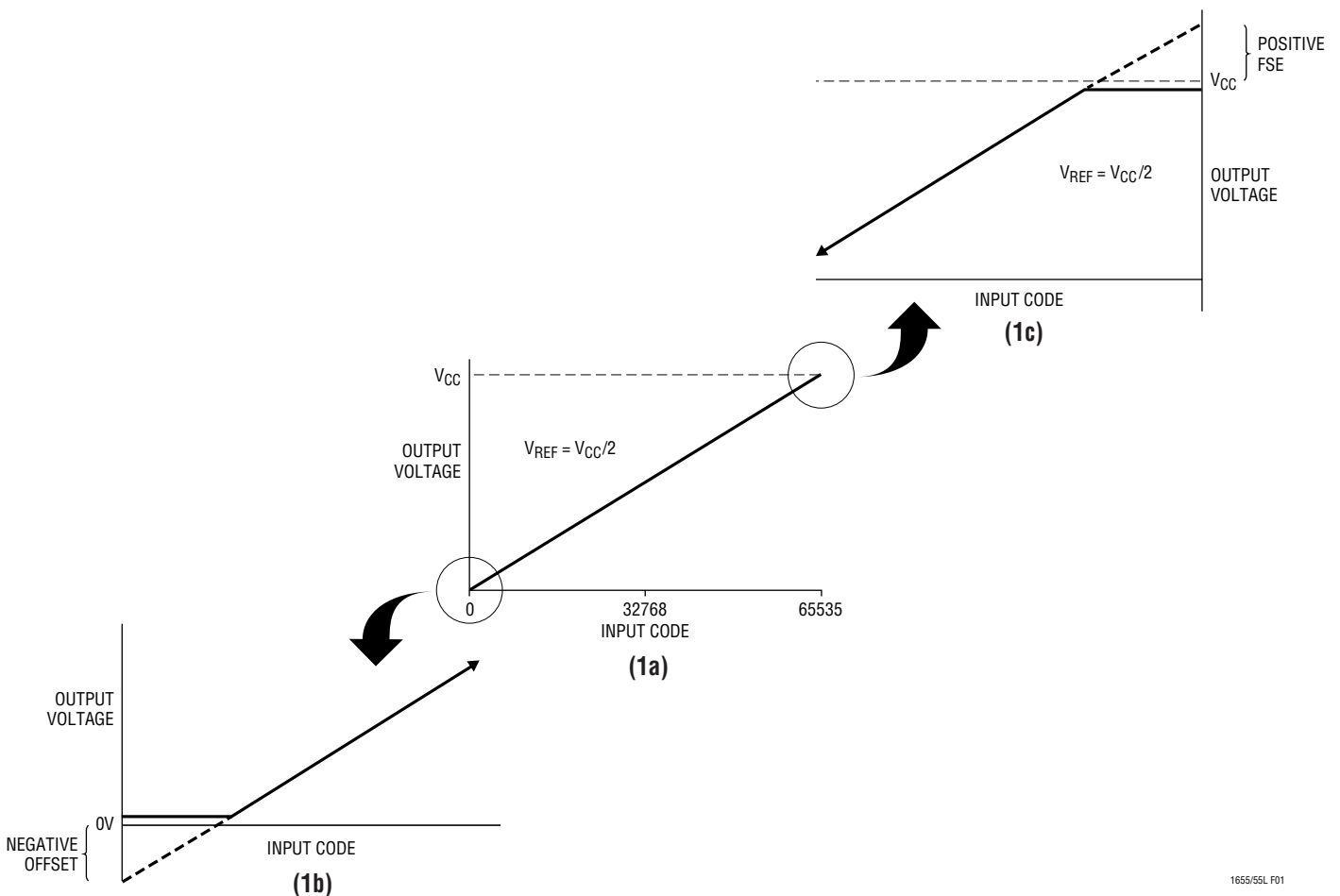

Figure 1. Effects of Rail-to-Rail Operation On a DAC Transfer Curve. (a) Overall Transfer Function (b) Effect of Negative Offset for Codes Near Zero Scale (c) Effect of Positive Full-Scale Error for Input Codes Near Full Scale When  $V_{REF} = V_{CC}/2$

## TYPICAL APPLICATIONS

This circuit shows how to use an LTC1655 to make an optoisolated digitally controlled 4mA to 20mA process controller. The controller circuitry, including the optoisolation, is powered by the loop voltage that can have a wide range of 6V to 30V. The 2.048V reference output of the LTC1655 is used for the 4mA offset current and  $V_{OUT}$

is used for the digitally controlled 0mA to 16mA current.  $R_S$  is a sense resistor and the op amp modulates the transistor Q1 to provide the 4mA to 20mA current through this resistor. The potentiometers allow for offset and full-scale adjustment. The control circuitry dissipates well under the 4mA budget at zero scale.

An Isolated 4mA to 20mA Process Controller

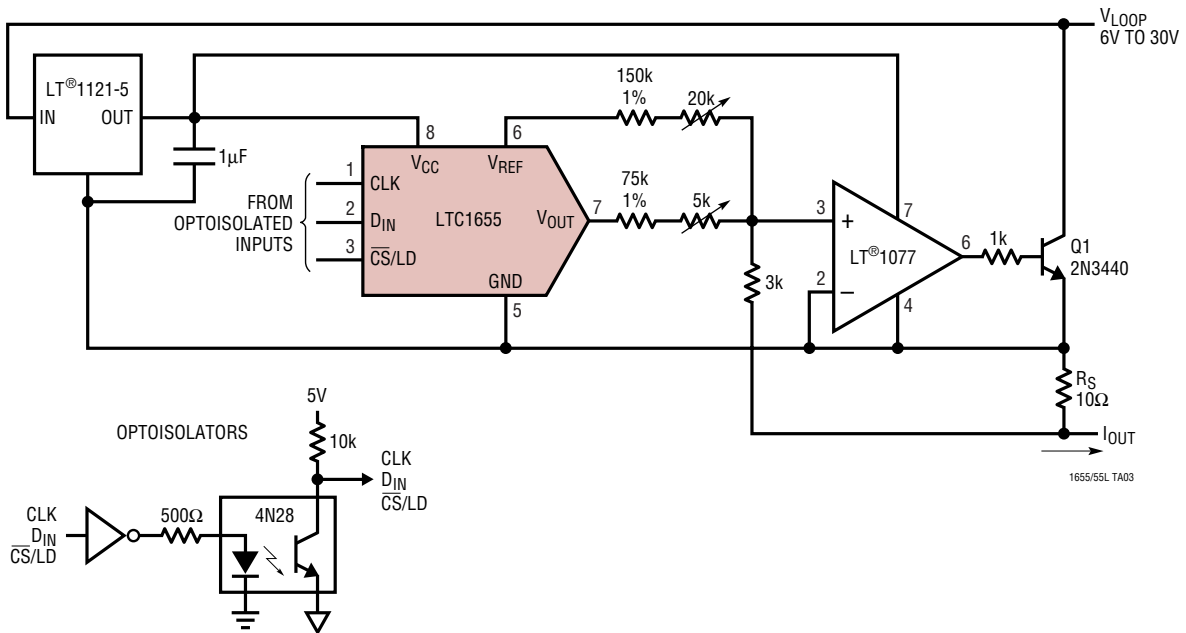

## TYPICAL APPLICATIONS

This circuit shows how to make a bipolar output 16-bit DAC with a wide output swing using an LTC1655 and an LT1077. R1 and R2 resistively divide down the LTC1655 output and an offset is summed in using the LTC1655 onboard 2.048V reference and R3 and R4. R5 ensures that

the onboard reference is always sourcing current and never has to sink any current even when  $V_{OUT}$  is at full scale. The LT1077 output will have a wide bipolar output swing of  $-4.096V$  to  $4.096V$  as shown in the figure below. With this output swing  $1LSB = 125\mu V$ .

**A Wide Swing, Bipolar Output 16-Bit DAC**

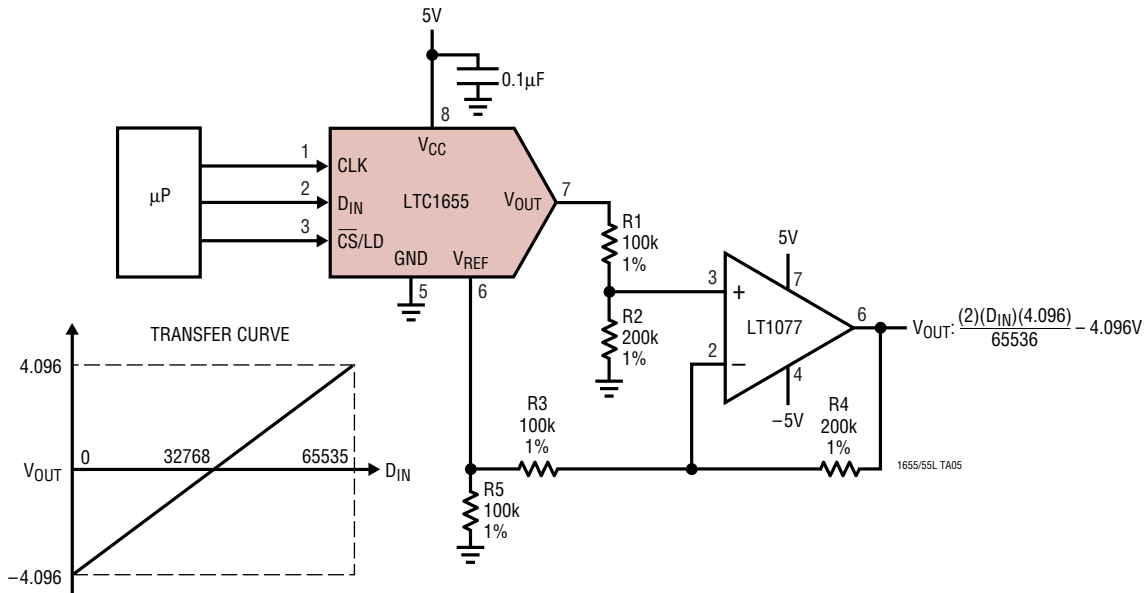

## TYPICAL APPLICATIONS

This circuit shows a digitally programmable current source from an external voltage source using an external op amp, an LT1218 and an NPN transistor (2N3440). Any digital word from 0 to 65535 is loaded into the LTC1655 and its output correspondingly swings from 0V to 4.096V. This voltage will be forced across the resistor  $R_A$ . If  $R_A$  is

chosen to be  $412\Omega$ , the output current will range from 0mA at zero scale to 10mA at full scale. The minimum voltage for  $V_S$  is determined by the load resistor  $R_L$  and Q1's  $V_{CESAT}$  voltage. With a load resistor of  $50\Omega$ , the voltage source can be 5V.

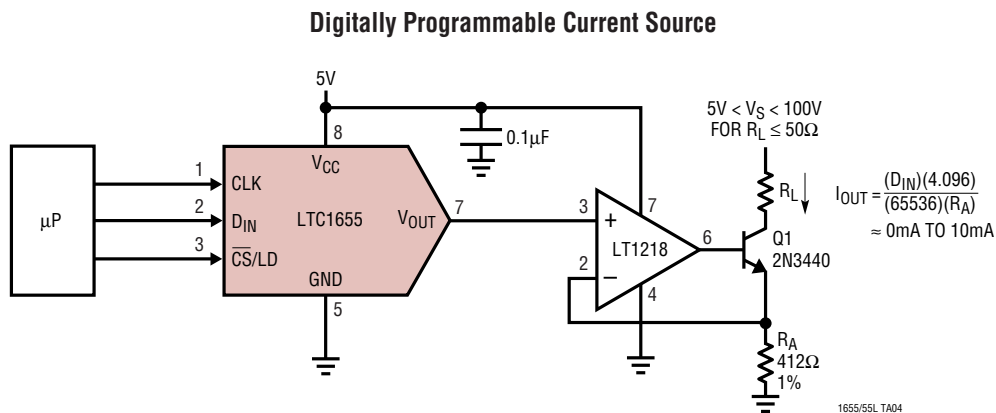

**PACKAGE DESCRIPTION** Dimensions in inches (millimeters) unless otherwise noted.

**N8 Package**  
**8-Lead PDIP (Narrow 0.300)**  
 (LTC DWG # 05-08-1510)

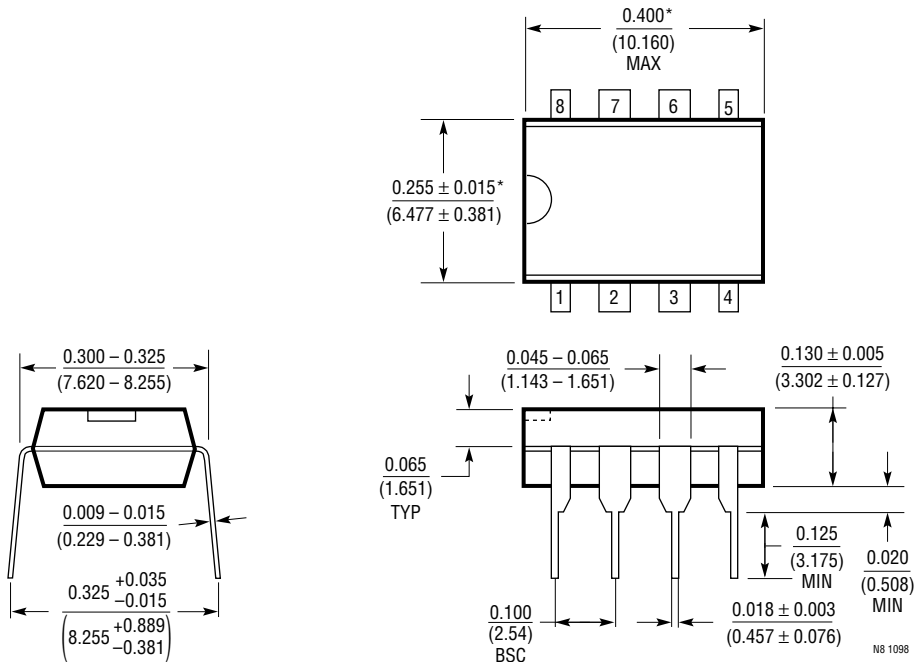

\*THESE DIMENSIONS DO NOT INCLUDE MOLD FLASH OR PROTRUSIONS.  
 MOLD FLASH OR PROTRUSIONS SHALL NOT EXCEED 0.010 INCH (0.254mm)

**PACKAGE DESCRIPTION** Dimensions in inches (millimeters) unless otherwise noted.

**S8 Package**  
**8-Lead Plastic Small Outline (Narrow 0.150)**  
 (LTC DWG # 05-08-1610)

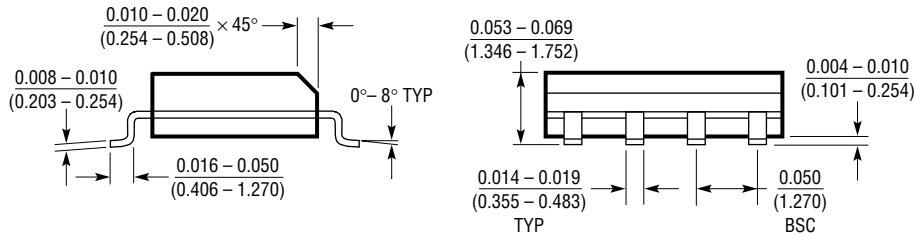
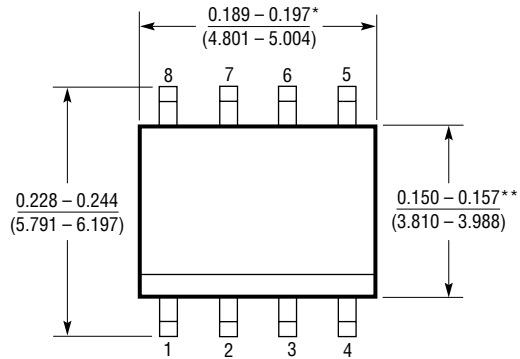

\*DIMENSION DOES NOT INCLUDE MOLD FLASH. MOLD FLASH SHALL NOT EXCEED 0.006" (0.152mm) PER SIDE

\*\*DIMENSION DOES NOT INCLUDE INTERLEAD FLASH. INTERLEAD FLASH SHALL NOT EXCEED 0.010" (0.254mm) PER SIDE

508 1298

## TYPICAL APPLICATION

This circuit shows how to measure negative offset. Since LTC1655/LTC1655L operate on a single supply, if its offset is negative, the output for code 0 limits to 0V. To

measure this negative offset, a negative supply is needed. Connect resistor R1 as shown in the figure below. The output voltage is the offset when code 0 is loaded in.

Negative Offset Measurement

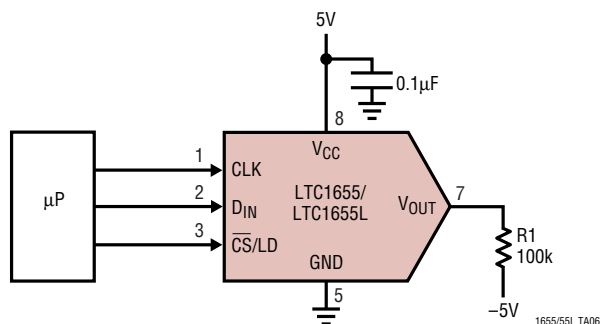

## RELATED PARTS

PART NUMBER	DESCRIPTION	COMMENTS
LTC1257	Single 12-Bit $V_{OUT}$ DAC, Full Scale: 2.048V, $V_{CC}$ : 4.75V to 15.75V, in Reference Can Be Overdriven Up to 12V, i.e., $FS_{MAX} = 12V$	5V to 15V Single Supply, Complete $V_{OUT}$ DAC SO-8 Package
LTC1446/ LTC1446L	Dual 12-Bit $V_{OUT}$ DACs in SO-8 Package	LTC1446: $V_{CC} = 4.5V$ to 5.5V, $V_{OUT} = 0V$ to 4.095V LTC1446L: $V_{CC} = 2.7V$ to 5.5V, $V_{OUT} = 0V$ to 2.5V
LTC1448	Dual 12-Bit $V_{OUT}$ DAC, $V_{CC}$ : 2.7V to 5.5V	Output Swings from GND to REF. REF Input Can Be Tied to $V_{CC}$
LTC1450/ LTC1450L	Single 12-Bit $V_{OUT}$ DACs with Parallel Interface	LTC1450: $V_{CC} = 4.5V$ to 5.5V, $V_{OUT} = 0V$ to 4.095V LTC1450L: $V_{CC} = 2.7V$ to 5.5V, $V_{OUT} = 0V$ to 2.5V
LTC1451	Single Rail-to-Rail 12-Bit DAC, Full Scale: 4.095V, $V_{CC}$ : 4.5V to 5.5V, Internal 2.048V Reference Brought Out to Pin	5V, Low Power Complete $V_{OUT}$ DAC in SO-8 Package
LTC1452	Single Rail-to-Rail 12-Bit $V_{OUT}$ Multiplying DAC, $V_{CC}$ : 2.7V to 5.5V	Low Power, Multiplying $V_{OUT}$ DAC with Rail-to-Rail Buffer Amplifier in SO-8 Package
LTC1453	Single Rail-to-Rail 12-Bit $V_{OUT}$ DAC, Full Scale: 2.5V, $V_{CC}$ : 2.7V to 5.5V	3V, Low Power, Complete $V_{OUT}$ DAC in SO-8 Package
LTC1454/ LTC1454L	Dual 12-Bit $V_{OUT}$ DACs in SO-16 Package with Added Functionality	LTC1454: $V_{CC} = 4.5V$ to 5.5V, $V_{OUT} = 0V$ to 4.095V LTC1454L: $V_{CC} = 2.7V$ to 5.5V, $V_{OUT} = 0V$ to 2.5V
LTC1456	Single Rail-to-Rail Output 12-Bit DAC with Clear Pin, Full Scale: 4.095V, $V_{CC}$ : 4.5V to 5.5V	Low Power, Complete $V_{OUT}$ DAC in SO-8 Package with Clear Pin
LTC1458/ LTC1458L	Quad 12 Bit Rail-to-Rail Output DACs with Added Functionality	LTC1458: $V_{CC} = 4.5V$ to 5.5V, $V_{OUT} = 0V$ to 4.095V LTC1458L: $V_{CC} = 2.7V$ to 5.5V, $V_{OUT} = 0V$ to 2.5V
LTC1650	Single 16-Bit $V_{OUT}$ Industrial DAC in 16-Pin SO, $V_{CC} = \pm 5V$	Low Power, Deglitched, 4-Quadrant Multiplying $V_{OUT}$ DAC, Output Swing $\pm 4.5V$
LTC1654	Dual 14-Bit DAC	1LSB DNL, 2 DACs in SO-8 Footprint
LTC1657/ LTC1657L	Single 16-Bit $V_{OUT}$ DAC with Parallel Interface	LTC1657: $V_{CC} = 5V$ , Low Power, Deglitched, $V_{OUT} = 0V$ to 4.096V LTC1657L: $V_{CC} = 3V$ , Low Power, Deglitched, $V_{OUT} = 0V$ to 2.5V
LTC1658	Single Rail-to-Rail 14-Bit $V_{OUT}$ DAC in 8-Pin MSOP, $V_{CC} = 2.7V$ to 5.5V	Low Power, Multiplying $V_{OUT}$ DAC in MS8 Package. Output Swings from GND to REF. REF Input Can Be Tied to $V_{CC}$
LTC1659	Single Rail-to-Rail 12-Bit $V_{OUT}$ DAC in 8-Pin MSOP, $V_{CC} = 2.7V$ to 5.5V	Low Power, Multiplying $V_{OUT}$ DAC in MS8 Package. Output Swings from GND to REF. REF Input Can Be Tied to $V_{CC}$