

DETAIL C
SCALE 4 : 1

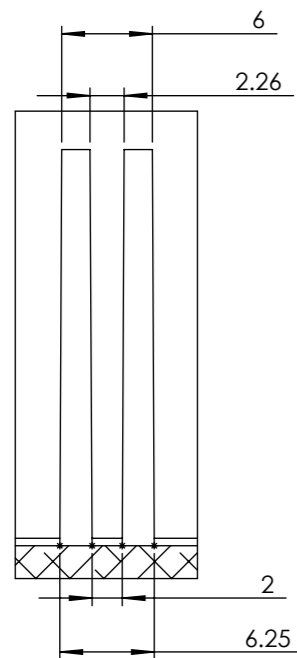

DETAIL D
SCALE 2 : 1



DETAILS OF HOLES:
CAST AS SHOWN, DRILL
Ø 3.2 ± 0.05 X 13.0 ± 0.5 DEEP

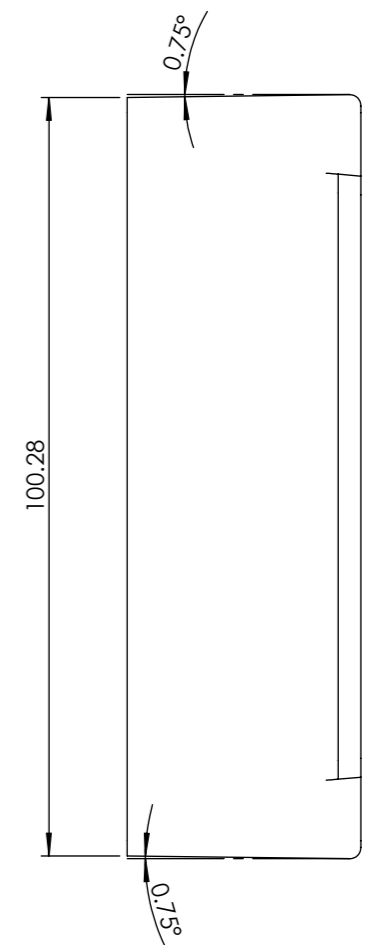
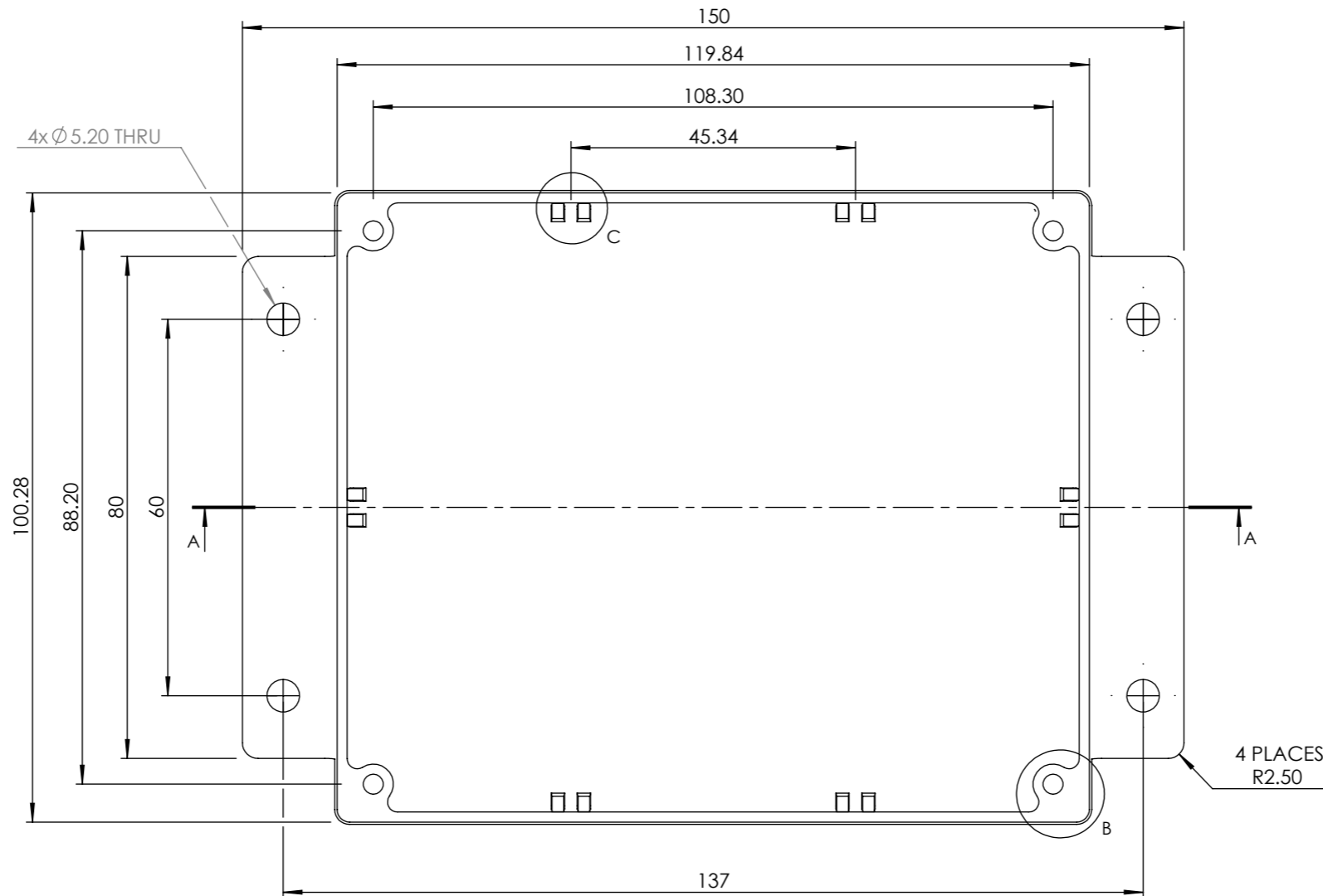

DETAIL B
SCALE 2 : 1

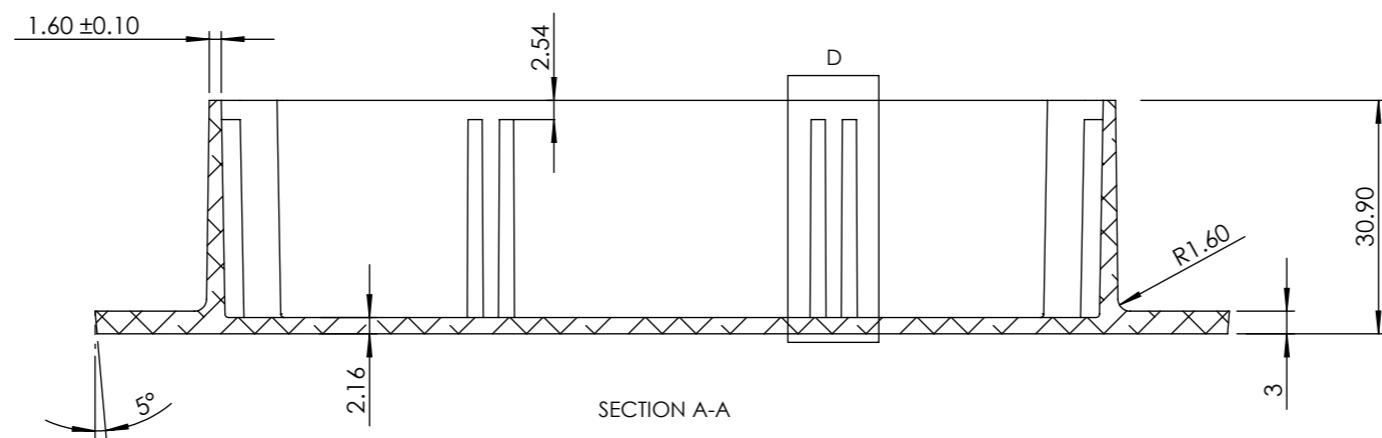

SECTION A-A

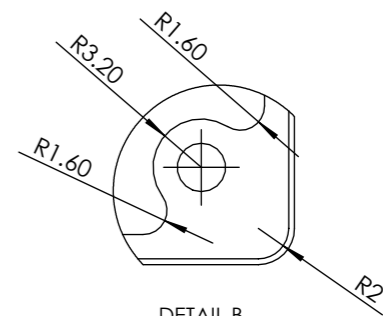

		FLANGED	
SIZE	PLAIN	POWDER COATED	NYLON COATED
M	455-0120	457-0120	458-0120
	SEALED	FLANGED	
M	456-0120	463-0120	464-0120

Tel No. +44(0)1724273200 Website www.dem-uk.com



PROPRIETARY AND CONFIDENTIAL
THE INFORMATION CONTAINED IN THIS DRAWING IS THE SOLE PROPERTY OF ALPHA 3 MANUFACTURING.
ANY REPRODUCTION IN PART OR AS A WHOLE WITHOUT THE WRITTEN PERMISSION OF ALPHA 3 MANUFACTURING IS PROHIBITED.

DEM Manufacturing, Deltron Emcon House
Hargreaves Way, Sawcliffe Ind. Park,
Scunthorpe, North Lincolnshire, DN15 8RF, UK

UNLESS OTHERWISE SPECIFIED:
DIMENSIONS ARE IN MILLIMETRES
LINEAR TOLERANCE:
NO DECIMAL PLACES ± 0.5mm
1 DECIMAL PLACE ± 0.25mm
2 DECIMAL PLACES ± 0.125mm
ANGULAR TOLERANCE: ± 1°

FINISH
DEBURR AND BREAK SHARP EDGES
DRAWN BY B.SILLENCE
APPROVED BY B.SILLENCE
THIRD ANGLE PROJECTION
IF IN DOUBT ASK DO NOT SCALE DRAWING
MATERIAL DieCast Aluminium Alloy

SHEET 1 OF 1
SCALE 1:1
A3

TITLE **PROCUREMENT SPECIFICATION FOR 'M' SIZE FLANGED BOX**
DRAWING NO. **M BOX FLANGED**
ISSUE **02**
Release