

RELAYS AND CONTACTORS

D.C. Power Contactors – Type 120



Type 120

Sec.	STANCOR PART NUMBER	Duty Cycle	Terminal Type*	Pole Form	Bracket Style	Coil Volt. D.C.	Coil Resistance (Ohms) @ 25°C	Contact Material	Contact Rating-(Amps.) Inductive Load				DIMENSIONS INCHES			Weight (oz.)	Agency-Certif.	
									Volt. D.C.	Normally Open Continuous	Normally Closed Continuous	Normally Open Inrush**	Normally Closed Inrush	L	Case W			H
A	120-901	Continuous	4	SPNO	Standard	12	16.0	Silver Alloy	12	100	400	-	-	2.13	2.88	3.25	6.0	-
	120-907	Continuous	4	SPNO	L	12	16.0	Silver Alloy	12	100	400	-	-	2.50	3.00	3.25	6.0	-
	120-943	Continuous	5	SPNO	L	12	16.0	Silver Alloy	12	100	400	-	-	2.50	3.00	3.25	6.0	-
	120-913	Continuous	3	SPNO	Standard	12	16.0	Silver Alloy	12	100	400	-	-	2.13	2.88	3.25	6.0	-
B	120-906	Intermittent‡	4	SPNO	Standard	12	6.0	Copper	12	80	400	-	-	2.13	2.88	3.25	6.0	-
	120-912	Intermittent‡	4	SPNO	L	12	6.0	Copper	12	80	400	-	-	2.50	3.00	3.25	6.0	-
	120-902	Continuous	4	SPNO	Standard	15	20.8	Silver Alloy	15	100	400	-	-	2.13	2.88	3.25	6.0	-
	120-908	Continuous	4	SPNO	L	15	20.8	Silver Alloy	15	100	400	-	-	2.50	3.00	3.25	6.0	-
	120-903	Continuous	4	SPNO	Standard	18	37.0	Silver Alloy	18	100	400	-	-	2.13	2.88	3.25	6.0	-
C	120-904	Continuous	4	SPNO	Standard	24	64.0	Silver Alloy	24	100	400	-	-	2.13	2.88	3.25	6.0	-
	120-910	Continuous	4	SPNO	L	24	64.0	Silver Alloy	24	100	400	-	-	2.50	3.00	3.25	6.0	-
	120-905	Continuous	4	SPNO	Standard	36	160.0	Silver Alloy	36	100	400	-	-	2.13	2.88	3.25	6.0	-
	120-911	Continuous	4	SPNO	L	36	160.0	Silver Alloy	36	100	400	-	-	2.50	3.00	3.25	6.0	-
D	120-914	Continuous	6	SPNO	Standard	15	23.0	Silver Nickel	15	100	400	-	-	2.13	2.87	3.09	6.0	-
	120L-915	Continuous	7	SPNO	L	12	6.0	Silver Alloy	12	80	400	-	-	2.50	3.00	3.14	6.0	-

— Water Resistant

For outline drawings refer to page 53.

‡ Intermittent Duty Cycle = 30 seconds "on" maximum and 6 minutes "off"

* Terminal Type: "4" = Isolated Coil, "6" = Isolated Coil Automotive, "7" = Latching Contacts

** Inrush Current: Current applied within the first 1/2 second of contact closure

Engineering Design Data

D.C. Type	Coil Rating Nominal Magnetic Coil Rating (Watts)	Operation in % of Nom. Coil Voltage Rating		Breakdown Voltages All Terminals - 60 Hz RMS			Contact Material		Electrical Life		Mechanical Life		Max. Oper. Temp. °F
		Pick-up	Max. Safe Operate	Opposite Polarity	Open Contacts Same Polarity	To Ground	Power	Pilot	Oper. At Rated Load	Oper. Per Min.	Oper. At No Load	Oper. Per Min.	
120	-	75%	110%	500	500	500	Copper	-	10,000	2	100,000	30	150
							Silver Alloy		50,000	2	100,000	30	

Temperature Range

- Intermittent Duty: -20°F to 150°F
- Continuous Duty: -20°F to 120°F

Power (approximate)

- Continuous 8.1 watts
- Intermittent 14.4 watts

Terminations

- Contacts: 5/16" - 24 studs, UNF - 2A thread
- Coil: #10-32, UNF - 2A thread

Recommended Mounting

- Coil terminals up or horizontal

Hardware Torque Specification

- Contact Terminal: 45-55 inch-lbs.
- Coil Terminal: 12-18 inch-lbs.
- **Caution: A back up wrench *must* be used to hold the bottom nut stationary**

Type 120 Custom Design Capabilities

- Coil Voltages 6VDC through 48VDC
- 1/4" Contact Studs
- 1/4" Q.C. Coil Terminals
- U.L. 94-VO rated case material
- Please complete application data form on page 95 of this section

Note: Caution must be used in coil selection for use in 12 volt systems where battery charging may expose coil to continuous, higher-than-rated voltage. Stancor will not be responsible for consequences of misapplied solenoids.

Terminal Type 3 – Grounded Coil to Bracket

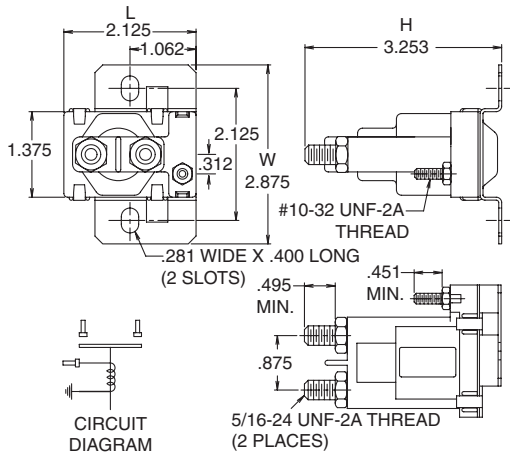

Terminal Type 6 – Delphi Connection (STD Bracket)

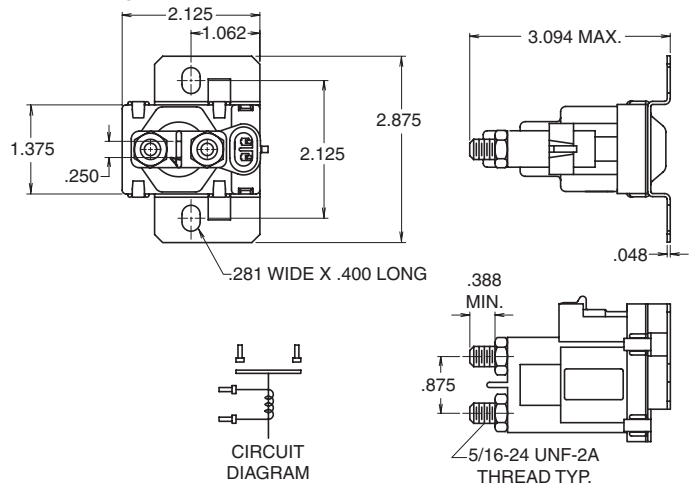

Terminal Type 4 – Isolated Coil (L Bracket)

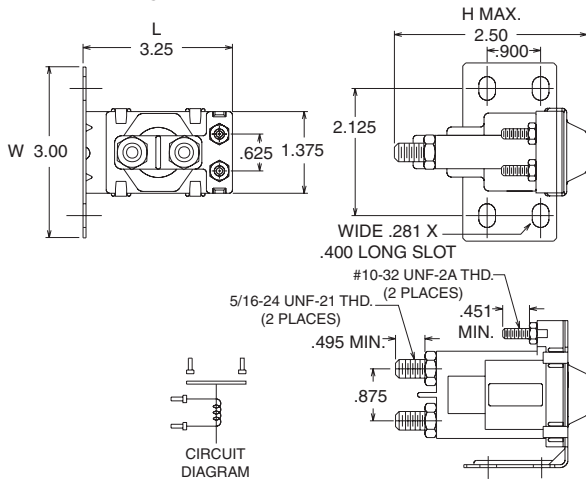

Terminal Type 7 – Latching Coil (L Bracket)

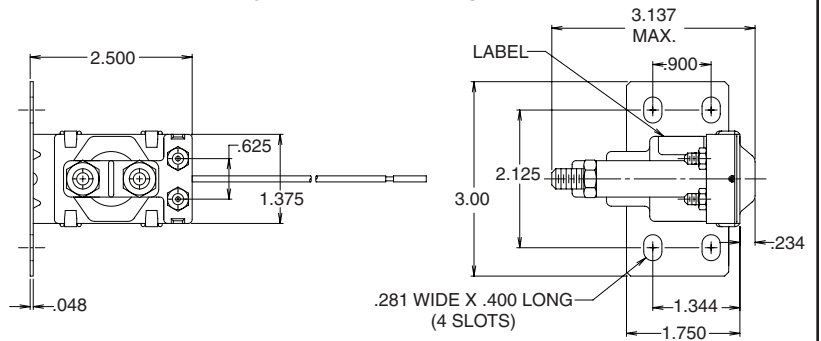

Terminal Type 5 – Grounded Coil with Q.C. Terminal

