

FSQ110

Green Mode Fairchild Power Switch (FPS™)

Features

- Internal Avalanche-Rugged 650V SenseFET
- Consumes only 0.65W at 230 V_{AC} & 0.3W Load with Burst-Mode Operation
- Precision Fixed Operating Frequency: 100kHz
- Internal Start-up Circuit and Built-in Soft-Start
- Pulse-by-Pulse Current Limiting and Auto-Restart Mode
- Over-Voltage Protection (OVP), Overload Protection (OLP), Internal Thermal Shutdown Function (TSD)
- Under-Voltage Lockout (UVLO)
- Low Operating Current: 3mA
- Adjustable Peak Current Limit

Applications

- SMPS for STB, Low-cost DVD

Related Application Notes

- [AN-4134: Design Guidelines for Off-line Forward Converters Using Fairchild Power Switch \(FPS™\)](#)
- [AN-4137: Design Guidelines for Off-line Flyback Converters Using Fairchild Power Switch \(FPS™\)](#)
- [AN-4141: Troubleshooting and Design Tips for Fairchild Power Switch \(FPS™\) Flyback Applications](#)
- [AN-4147: Design Guidelines for RCD Snubber of Flyback](#)

Description

The FSQ110 consists of an integrated, current-mode, Pulse Width Modulator (PWM) and an avalanche-rugged 650V SenseFET. It is specifically designed for high-performance off-line Switch-Mode Power Supplies (SMPS) with minimal external components.

The integrated PWM controller features include: a fixed-frequency generating oscillator, Under-Voltage Lockout (UVLO) protection, Leading-Edge Blanking (LEB), an optimized gate turn-on/turn-off driver, Thermal Shutdown (TSD) protection, and temperature-compensated precision current sources for loop compensation and fault protection circuitry.

Compared to a discrete MOSFET and controller or RCC switching converter solution, the FSQ110 reduces total component count, design size, and weight while increasing efficiency, productivity, and system reliability. These devices provide a basic platform that is well suited for the design of cost-effective flyback converters.

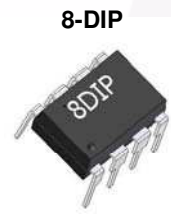

Ordering Information

Product Number	Package	Marking Code	BV _{DSS}	f _{OSC}	R _{DS(ON)} (MAX.)
FSQ110	8DIP	Q110	650V	100kHz	19Ω

 All package are lead free per JEDEC: J-STD-020B standard.

FPS™ is a trademark of Fairchild Semiconductor Corporation.

Application Diagram

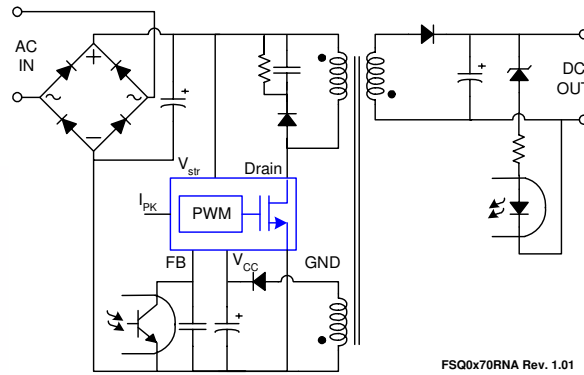

Figure 1. Typical Flyback Application

Output Power Table⁽¹⁾

Product	230V _{AC} ±15% ⁽²⁾		85–265V _{AC}	
	Adapter ⁽³⁾	Open Frame ⁽⁴⁾	Adapter ⁽³⁾	Open Frame ⁽⁴⁾
FSQ110	11W	17W	8W	12W

Notes:

1. The maximum output power can be limited by junction temperature.
2. 230 V_{AC} or 100/115 V_{AC} with doubler.
3. Typical continuous power in a non-ventilated enclosed adapter with sufficient drain pattern as a heat sink, at 50°C ambient.
4. Maximum practical continuous power in an open-frame design with sufficient drain pattern as a heat sink, at 50°C ambient.

Internal Block Diagram

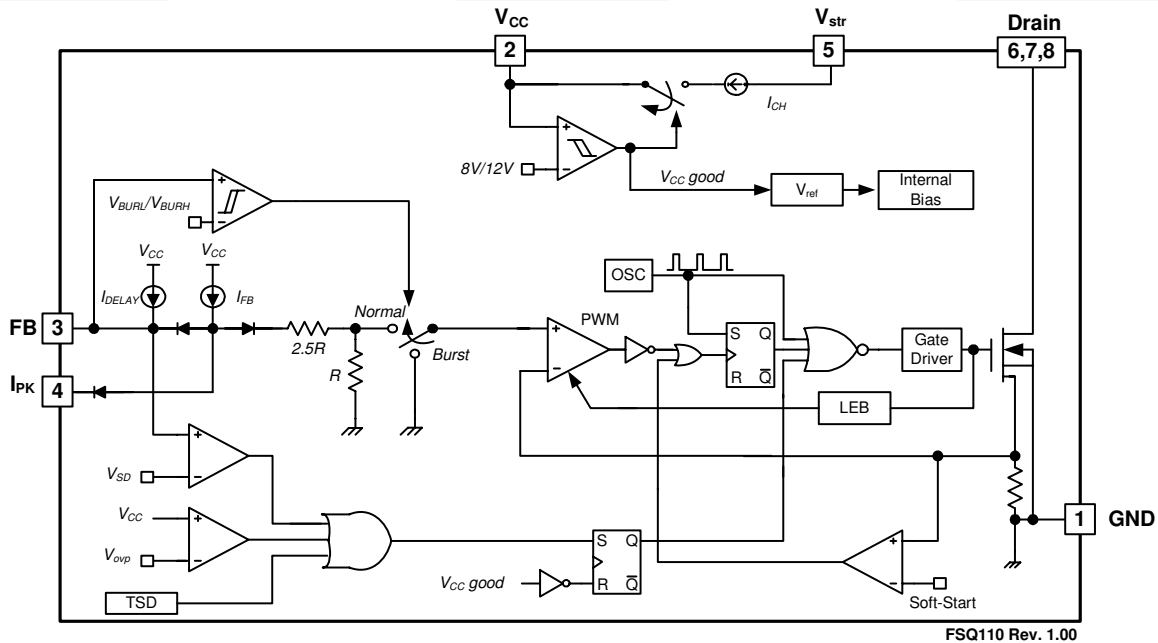

Figure 2. Internal Block Diagram

Pin Configuration

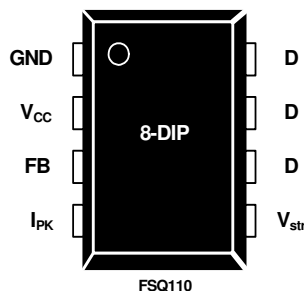

Figure 3. Pin Configuration (Top View)

Pin Definitions

Pin #	Name	Description
1	GND	Ground. SenseFET source terminal on primary side and internal control ground.
2	V _{CC}	Power Supply. Positive supply voltage input. Although connected to an auxiliary transformer winding, current is supplied from pin 5 (V _{str}) via an internal switch during start-up (see Figure 2). It is not until V _{CC} reaches the UVLO upper threshold (12V) that the internal start-up switch opens and device power is supplied via the auxiliary transformer winding.
3	FB	Feedback. The feedback voltage pin is the non-inverting input to the PWM comparator. It has a 0.9mA current source connected internally, while a capacitor and opto-coupler are typically connected externally. A feedback voltage of 6V triggers overload protection (OLP). A time delay while charging external capacitor C _{FB} from 3V to 6V using an internal 5μA current source delay prevents false triggering under transient conditions, but still allows the protection mechanism to operate under true overload conditions.
4	I _{PK}	Peak Current Limit. This pin adjusts the peak current limit of the SenseFET. The 0.9mA feedback current source is diverted to the parallel combination of an internal 2.8kΩ resistor and any external resistor to GND on this pin. This determines the peak current limit. If this pin is tied to V _{CC} or left floating, the typical peak current limit is 0.7A.
5	V _{str}	Start-up. This pin connects to the rectified AC line voltage source. At start-up, the internal switch supplies internal bias and charges an external storage capacitor placed between the V _{CC} pin and ground. Once the V _{CC} reaches 12V, the internal switch is opened.
6	D	SenseFET Drain. High-voltage power SenseFET drain connection.
7	D	SenseFET Drain. High-voltage power SenseFET drain connection.
8	D	SenseFET Drain. High-voltage power SenseFET drain connection.

Absolute Maximum Ratings

Stresses exceeding the absolute maximum ratings may damage the device. The device may not function or be operable above the recommended operating conditions and stressing the parts to these levels is not recommended. In addition, extended exposure to stresses above the recommended operating conditions may affect device reliability. The absolute maximum ratings are stress ratings only. $T_A = 25^\circ\text{C}$, unless otherwise specified.

Symbol	Characteristic	Value	Unit
V_{DRAIN}	Drain Pin Voltage	650	V
V_{STR}	Vstr Pin Voltage	650	V
I_{DM}	Drain Current Pulsed ⁽⁵⁾	1.5	A
E_{AS}	Single Pulsed Avalanche Energy ⁽⁶⁾	10	mJ
V_{CC}	Supply Voltage	20	V
V_{FB}	Feedback Voltage Range	-0.3 to V_{CC}	V
P_{D}	Total Power Dissipation	1.40	W
T_{J}	Operating Junction Temperature	Internally limited	$^\circ\text{C}$
T_{A}	Operating Ambient Temperature	-25 to +85	$^\circ\text{C}$
T_{STG}	Storage Temperature	-55 to +150	$^\circ\text{C}$

Notes:

5. Repetitive rating: Pulse width is limited by maximum junction temperature.

6. $L = 24\text{mH}$, starting $T_{\text{J}} = 25^\circ\text{C}$.

Thermal Impedance

$T_A = 25^\circ\text{C}$, unless otherwise specified. All items are tested with the standards JESD 51-2 and 51-10 (DIP).

Symbol	Parameter	Value	Unit
θ_{JA}	Junction-to-Ambient Thermal Resistance ⁽⁷⁾	88.84	$^\circ\text{C}/\text{W}$
θ_{JC}	Junction-to-Case Thermal Resistance ⁽⁸⁾	13.94	$^\circ\text{C}/\text{W}$

Notes:

7. Free standing with no heatsink; without copper clad.

(Measurement Condition - Just before junction temperature T_{J} enters into OTP.)

8. Measured on the DRAIN pin close to plastic interface.

Electrical Characteristics

$T_A = 25^\circ\text{C}$ unless otherwise specified.

Symbol	Parameter	Condition	Min.	Typ.	Max.	Unit
SenseFET Section⁽¹⁰⁾						
I_{DSS}	Zero-Gate-Voltage Drain Current	$V_{DS} = \text{Max. Rating}$ $V_{GS} = 0\text{V}$			25	μA
		$V_{DS} = 0.8 \text{ Max. Rating}$ $V_{GS} = 0\text{V}, T_C = 125^\circ\text{C}$			200	
$R_{DS(ON)}$	Drain-Source On-State Resistance ⁽¹¹⁾	$V_{GS} = 10\text{V}, I_D = 0.5\text{A}$		14	19	Ω
C_{ISS}	Input Capacitance	$V_{GS} = 0\text{V}, V_{DS} = 25\text{V},$ $f = 1\text{MHz}$		162		pF
C_{OSS}	Output Capacitance			18		
C_{RSS}	Reverse Transfer Capacitance			3.8		
$t_{d(on)}$	Turn-On Delay Time	$V_{DS} = 325\text{V}, I_D = 1\text{A}$		9.5		ns
t_r	Rise Time			19		
$t_{d(off)}$	Turn-Off Delay Time			33		
t_f	Fall Time			42		
Control Section						
f_{OSC}	Switching Frequency		92	100	108	KHz
Δf_{OSC}	Switching Frequency Variation ⁽¹⁰⁾	$-25^\circ\text{C} \leq T_A \leq 85^\circ\text{C}$		± 5	± 10	%
D_{MAX}	Maximum Duty Cycle	Measured at $0.1 \times V_{DS}$	55	60	65	%
V_{START}	UVLO Threshold Voltage	$V_{FB} = \text{GND}$	11	12	13	V
V_{STOP}		$V_{FB} = \text{GND}$	7	8	9	
I_{FB}	Feedback Source Current	$V_{FB} = \text{GND}$	0.7	0.9	1.1	mA
$t_{S/S}$	Internal Soft-Start Time ⁽¹⁰⁾	$V_{FB} = 4\text{V}$		10		ms
Burst-Mode Section						
V_{BURH}	Burst-Mode Voltage	$T_J = 25^\circ\text{C}$	0.5	0.6	0.7	V
V_{BURL}			0.3	0.4	0.5	V
$V_{BUR(HYS)}$			100	200	300	mV
Protection Section						
I_{LIM}	Peak Current Limit	$di/dt = 170\text{mA}/\mu\text{s}$	0.60	0.70	0.80	A
t_{CLD}	Current Limit Delay Time ⁽¹⁰⁾			600		ns
T_{SD}	Thermal Shutdown Temperature ⁽¹⁰⁾		125	140		$^\circ\text{C}$
V_{SD}	Shutdown Feedback Voltage		5.5	6.0	6.5	V
V_{OVP}	Over-Voltage Protection		18	19	20	V
I_{DELAY}	Shutdown Delay Current	$V_{FB} = 4\text{V}$	3.5	5.0	6.5	μA
t_{LEB}	Leading-Edge Blanking Time ⁽¹⁰⁾		200			ns
Total Device Section						
I_{OP}	Operating Supply Current (control part only)	$V_{CC} = 14\text{V}$	1	3	5	mA
I_{CH}	Start-Up Charging Current	$V_{CC} = 0\text{V}$	0.70	0.85	1.00	mA
V_{STR}	V_{str} Supply Voltage	$V_{CC} = 0\text{V}$		24		V

Notes:

10. These parameters, although guaranteed, are not 100% tested in production.

11. Pulse test: Pulse width $\leq 300\mu\text{s}$, duty $\leq 2\%$.

12. The ESD level of an existing product can be applied to FSQ110 because it has same ESD protection circuit.

Typical Performance Characteristics (Control Part)

These characteristic graphs are normalized at $T_A = 25^\circ\text{C}$.

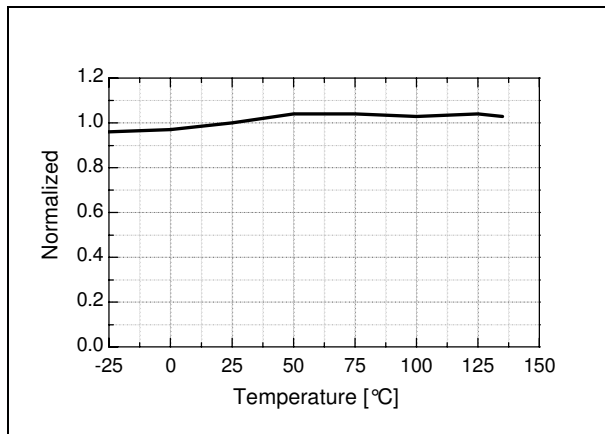

Figure 4. Operating Frequency (f_{OSC}) vs. T_A

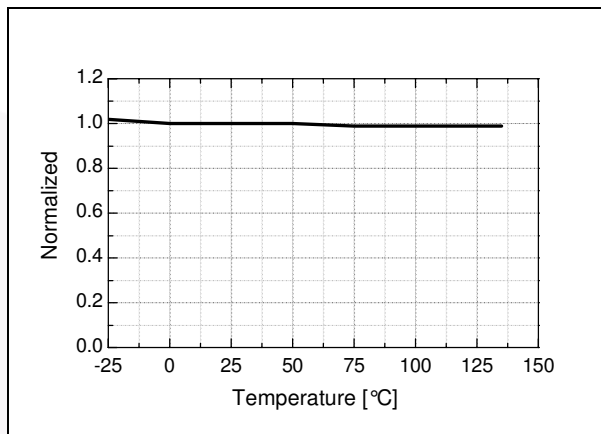

Figure 5. Over-Voltage Protection (V_{OVP}) vs. T_A

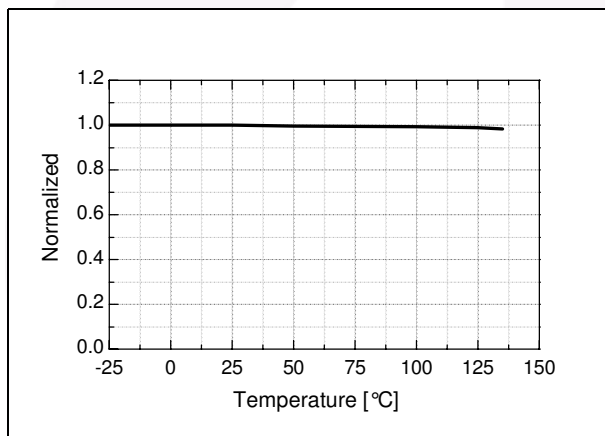

Figure 6. Maximum Duty Cycle (D_{MAX}) vs. T_A

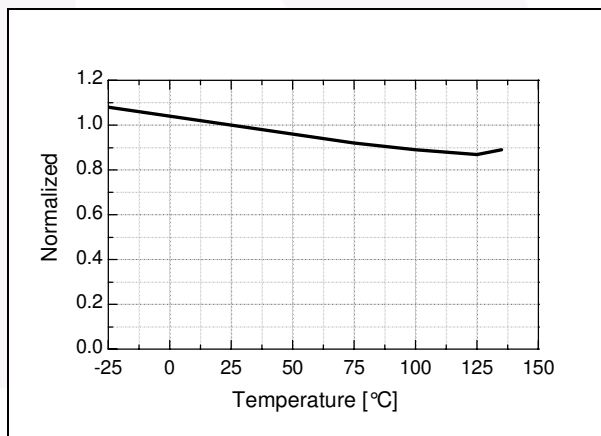

Figure 7. Operating Supply Current (I_{OP}) vs. T_A

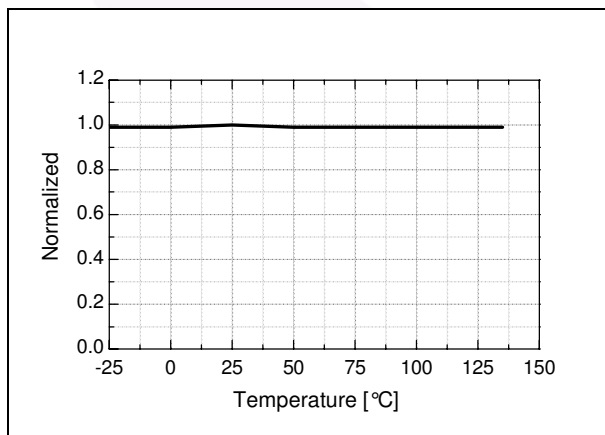

Figure 8. Start Threshold Voltage (V_{START}) vs. T_A

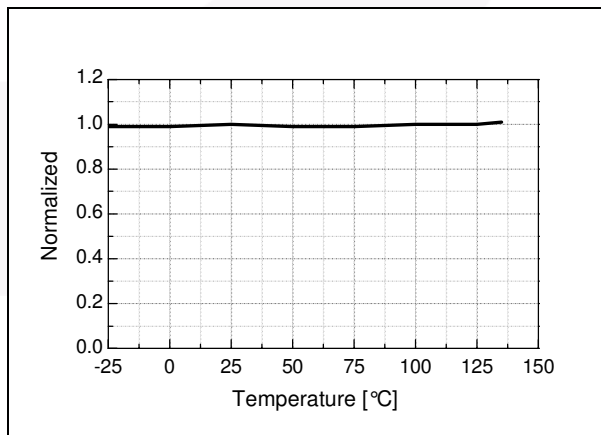

Figure 9. Stop Threshold Voltage (V_{STOP}) vs. T_A

Typical Performance Characteristics (Continued)

These characteristic graphs are normalized at $T_A = 25^\circ\text{C}$.

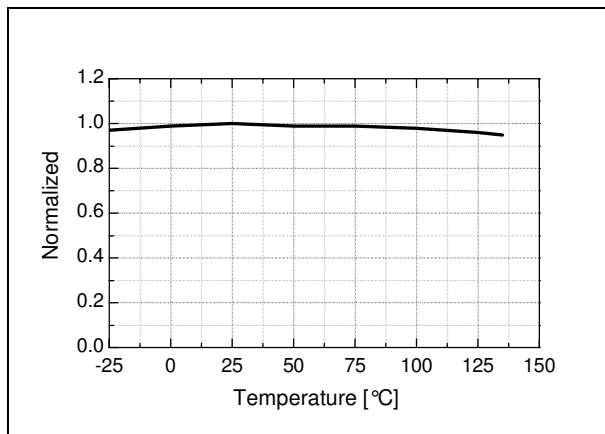

Figure 10. Feedback Source Current (I_{FB}) vs. T_A

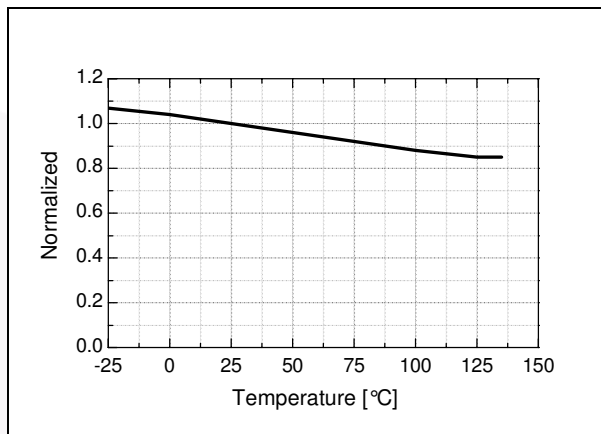

Figure 11. Start-Up Charging Current (I_{CH}) vs. T_A

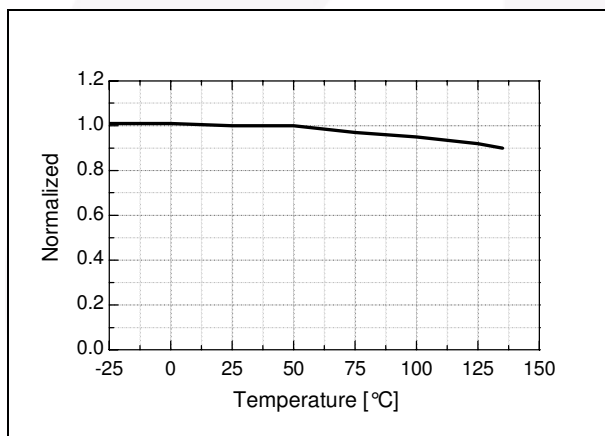

Figure 12. Peak Current Limit (I_{LIM}) vs. T_A

Functional Description

1. Startup: In previous generations of Fairchild Power Switches (FPS™), the V_{str} pin required an external resistor to the DC input voltage line. In this generation, the startup resistor is replaced by an internal high-voltage current source and a switch that shuts off 10ms after the supply voltage, V_{CC} , goes above 12V. The source turns back on if V_{CC} drops below 8V.

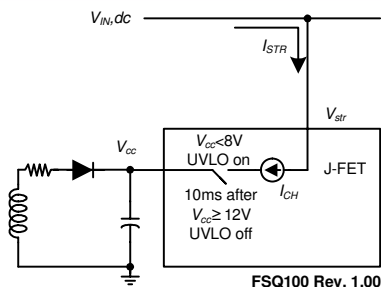

Figure 13. High-Voltage Current Source

2. Feedback Control: The FSQ110 employs current-mode control as shown in Figure 14. An opto-coupler (such as the H11A817A) and shunt regulator (such as the KA431) are typically used to implement the feedback network. Comparing the feedback voltage with the voltage across the R_{sense} resistor of SenseFET, plus an offset voltage, makes it possible to control the switching duty cycle. When the shunt regulator reference pin voltage exceeds the internal reference voltage of 2.5V, the opto-coupler LED current increases, the feedback voltage V_{FB} is pulled down and thereby reduces the duty cycle. This typically happens when the input voltage increases or the output load decreases.

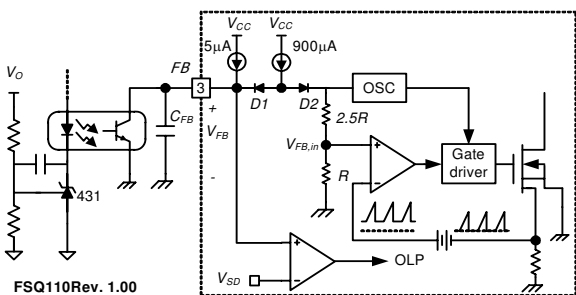

Figure 14. Pulse Width Modulation Circuit

3. Leading-Edge Blanking (LEB): When the internal SenseFET is turned on, the primary-side capacitance and secondary-side rectifier diode reverse recovery typically cause a high-current spike through the SenseFET. Excessive voltage across the R_{sense} resistor leads to incorrect feedback operation in the current-mode PWM control. To counter this effect, the FPS employs a Leading-Edge Blanking (LEB) circuit. This circuit inhibits the PWM comparator for a short time (t_{LEB}) after the SenseFET is turned on.

4. Protection Circuits: The FPS has several protective functions, such as Overload Protection (OLP), Over-Voltage Protection (OVP), Under-Voltage Lockout (UVLO), and Thermal Shutdown (TSD). Because these protection circuits are fully integrated in the IC without external components, reliability is improved without increasing cost. Once a fault condition occurs, switching is terminated and the SenseFET remains off. This causes V_{CC} to fall. When V_{CC} reaches the UVLO stop voltage, V_{STOP} (typically 8V), the protection is reset and the internal high-voltage current source charges the V_{CC} capacitor via the V_{str} pin. When V_{CC} reaches the UVLO start voltage, V_{START} (typically 12V), the FPS resumes normal operation. In this manner, the auto-restart can alternately enable and disable the switching of the power SenseFET until the fault condition is eliminated.

4.1 Overload Protection (OLP): Overload is defined as the load current exceeding a pre-set level due to an unexpected event. In this situation, the protection circuit should be activated to protect the SMPS. However, even when the SMPS is operating normally, the OLP circuit can be activated during the load transition. To avoid this undesired operation, the OLP circuit is designed to be activated after a specified time to determine whether it is a transient situation or a true overload situation. In conjunction with the I_{PK} current limit pin (if used), the current mode feedback path limits the current in the SenseFET when the maximum PWM duty cycle is attained. If the output consumes more than this maximum power, the output voltage (V_O) decreases below nominal voltage. This reduces the current through the opto-coupler LED, which also reduces the opto-coupler transistor current, increasing the feedback voltage (V_{FB}). If V_{FB} exceeds 3V, the feedback input diode is blocked and the $5\mu A$ current source (I_{DELAY}) starts to slowly charge C_{FB} up to V_{CC} . In this condition, V_{FB} increases until it reaches 6V, when the switching operation is terminated, as shown in Figure 15. The shutdown delay time is the time required to charge C_{FB} from 3V to 6V with $5\mu A$ current source.

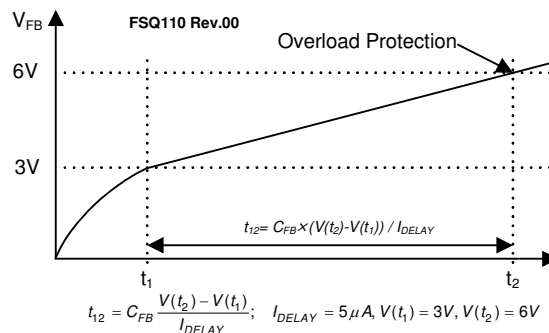

Figure 15. Overload Protection (OLP)

4.2 Thermal Shutdown (TSD): The SenseFET and the control IC are integrated, making it easier for the control IC to detect the temperature of the SenseFET. When the temperature exceeds approximately 140°C, thermal shutdown is activated.

4.3 Over-Voltage Protection (OVP): In the event of a malfunction in the secondary-side feedback circuit or an open-feedback loop caused by a soldering defect, the current through the opto-coupler transistor becomes almost zero (see Figure 14). V_{FB} climbs up in a similar manner to the overload situation, forcing the preset maximum current to be supplied to the SMPS until the overload protection is activated. Because excess energy is provided to the output, the output voltage may exceed the rated voltage before the overload protection is activated, resulting in the breakdown of the devices in the secondary side. To prevent this situation, an Over-Voltage Protection (OVP) circuit is employed. In general, V_{CC} is proportional to the output voltage and the FPS uses V_{CC} instead of directly monitoring the output voltage. If V_{CC} exceeds 19V, the OVP circuit is activated, resulting in termination of the switching operation. To avoid undesired activation of OVP during normal operation, V_{CC} should be designed to be below 19V.

5. Soft-Start: The FPS has an internal soft-start circuit that slowly increases the SenseFET current after start-up, as shown in Figure 16. The typical soft-start time is 10ms, where progressive increments of the SenseFET current are allowed during the start-up phase. The pulse width to the power switching device is progressively increased to establish the correct working conditions for transformers, inductors, and capacitors. The voltage on the output capacitors is progressively increased to smoothly establish the required output voltage. This also helps prevent transformer saturation and reduces the stress on the secondary diode during startup.

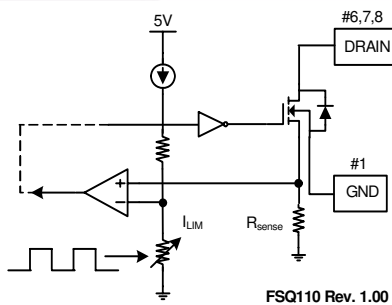

Figure 16. Soft-Start Function

6. Burst Operation: To minimize power dissipation in standby mode, the FPS enters burst-mode operation. Feedback voltage decreases as the load decreases, as shown in Figure 17, and the device automatically enters

burst-mode when the feedback voltage drops below V_{BURH} (typically 600mV). Switching continues until the feedback voltage drops below V_{BURL} (typically 400mV). At this point, switching stops and the output voltage starts to drop at a rate dependent on the standby current load. This causes the feedback voltage to rise. Once it passes V_{BURH} , switching resumes. The feedback voltage then falls and the process is repeated. Burst-mode operation alternately enables and disables switching of the SenseFET and reduces switching loss in standby mode.

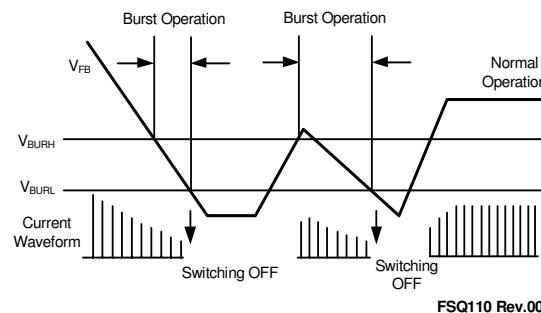

Figure 17. Burst Operation Function

7. Adjusting Peak Current Limit: As shown in Figure 18, a combined 2.8kΩ internal resistance is connected to the non-inverting lead on the PWM comparator. An external resistance of R_x on the current limit pin forms a parallel resistance with the 2.8kΩ when the internal diodes are biased by the main current source of 900μA.

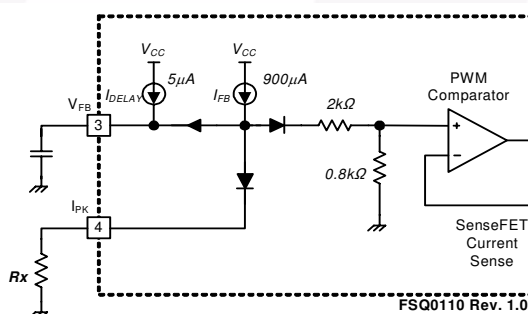

Figure 18. Peak Current Limit Adjustment

For example, FSQ110 has a typical SenseFET peak current limit (I_{LIM}) of 0.7A. I_{LIM} can be adjusted to 0.6A by inserting R_x between the I_{PK} pin and the ground. The value of the R_x is estimated by the following equation:

$$0.7A : 0.6A = 2.8k\Omega : Xk\Omega, \quad (1)$$

$$X = R_x \parallel 2.8k\Omega$$

where X is the resistance of the parallel network.

Application Information

Methods of Reducing Audible Noise

Switching-mode power converters have electronic and magnetic components, which generate audible noise when the operating frequency is in the range of 20~20,000Hz. Even though they operate above 20KHz, they can make noise, depending on the load condition. The following sections discuss methods to reduce noise.

Glue or Varnish

The most common method of reducing noise involves using glue or varnish to tighten magnetic components. The motion of core, bobbin, and coil and the chattering or magnetostriction of core can cause the transformer to produce audible noise. The use of rigid glue and varnish helps reduce the transformer noise. Glue or varnish can also crack the core because sudden changes in the ambient temperature cause the core and the glue to expand or shrink in a different ratio.

Ceramic Capacitor

Using a film capacitor instead of a ceramic capacitor as a snubber capacitor is another noise-reduction solution. Some dielectric materials show a piezoelectric effect, depending on the electric field intensity. A snubber capacitor becomes one of the most significant sources of audible noise. Another possibility is to use a Zener clamp circuit instead of an RCD snubber for higher efficiency as well as lower audible noise.

Adjusting Sound Frequency

Moving the fundamental frequency of noise out of the 2~4kHz range is a third method. Generally, humans are more sensitive to noise in the range of 2~4kHz. When the fundamental frequency of noise is located in this range, the noise sounds louder although the noise intensity level is identical (see Figure 19).

When the FPS acts in burst mode and the burst operation is suspected to be a source of noise, this method may be helpful. If the frequency of burst mode operation lies in the range of 2~4kHz, adjusting the feedback loop can shift the burst operation frequency. To reduce the burst operation frequency, increase a feedback gain capacitor (C_F), opto-coupler supply resistor (R_D), and feedback capacitor (C_B); and decrease a feedback gain resistor (R_F), as shown in Figure 20.

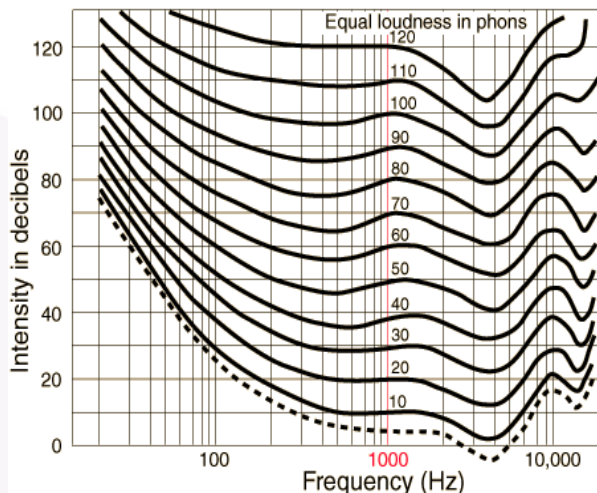

Figure 19. Equal Loudness Curves

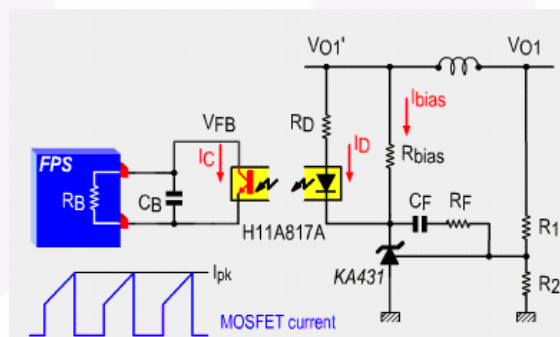
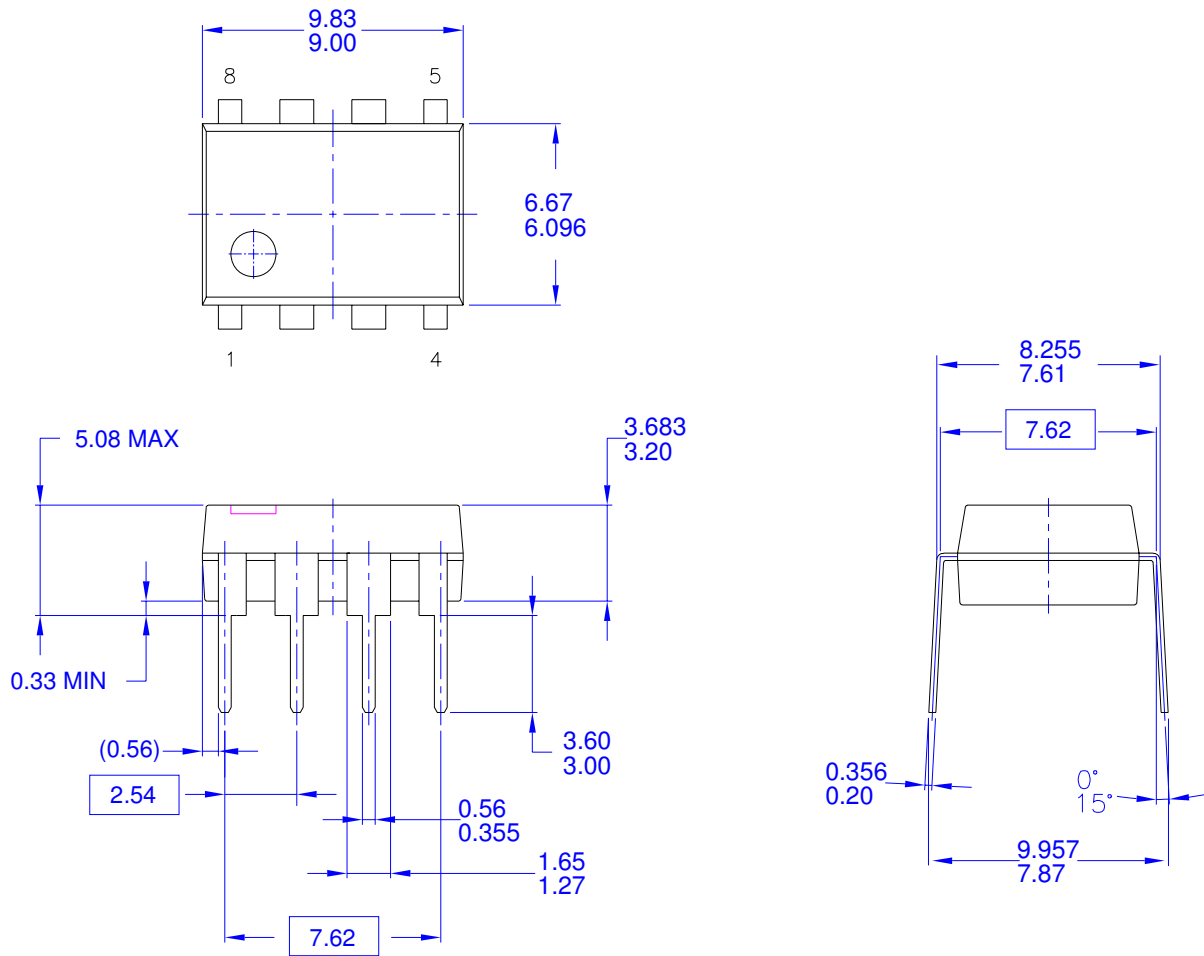

Figure 20. Typical Feedback Network of FPS

Reference Materials

- [AN-4134: Design Guidelines for Off-line Forward Converters Using Fairchild Power Switch \(FPS™\)](#)
- [AN-4137: Design Guidelines for Off-line Flyback Converters Using Fairchild Power Switch \(FPS™\)](#)
- [AN-4140: Transformer Design Consideration for Off-line Flyback Converters using Fairchild Power Switch \(FPS™\)](#)
- [AN-4141: Troubleshooting and Design Tips for Fairchild Power Switch \(FPS™\) Flyback Applications](#)
- [AN-4147: Design Guidelines for RCD Snubber of Flyback](#)
- [AN-4148: Audible Noise Reduction Techniques for FPS Applications](#)

Package Dimensions



NOTES: UNLESS OTHERWISE SPECIFIED

- A) THIS PACKAGE CONFORMS TO JEDEC MS-001 VARIATION BA
- B) ALL DIMENSIONS ARE IN MILLIMETERS.
- C) DIMENSIONS ARE EXCLUSIVE OF BURRS, MOLD FLASH, AND TIE BAR EXTRUSIONS.
- D) DIMENSIONS AND TOLERANCES PER ASME Y14.5M-1994
- E) DRAWING FILENAME AND REVISION: MKT-N08FREV2.

Figure 21. 8-Lead Dual In-Line Package (DIP)



TRADEMARKS

The following are registered and unregistered trademarks and service marks Fairchild Semiconductor owns or is authorized to use and is not intended to be an exhaustive list of all such trademarks.

- | | | | |
|--------------------------------------|--|----------------------------|----------------------------------|
| ACEX [®] | Green FPS™ | Power247 [®] | SuperSOT™-8 |
| Build it Now™ | Green FPS™ e-Series™ | POWEREDGE [®] | SyncFET™ |
| CorePLUS™ | GTO™ | Power-SPM™ | The Power Franchise [®] |
| CROSSVOLT™ | i-Lo™ | PowerTrench [®] | the power franchise |
| CTL™ | IntelliMAX™ | Programmable Active Droop™ | TinyBoost™ |
| Current Transfer Logic™ | ISOPLANAR™ | QFET [®] | TinyBuck™ |
| EcoSPARK [®] | MegaBuck™ | QS™ | TinyLogic [®] |
| F [®] | MICROCOUPLER™ | QT Optoelectronics™ | TINYOPTO™ |
| Fairchild [®] | MicroFET™ | Quiet Series™ | TinyPower™ |
| Fairchild Semiconductor [®] | MicroPak™ | RapidConfigure™ | TinyPWM™ |
| FACT Quiet Series™ | MillerDrive™ | SMART START™ | TinyWire™ |
| FACT [®] | Motion-SPM™ | SPM [®] | μSerDes™ |
| FAST [®] | OPTOLOGIC [®] | STEALTH™ | UHC [®] |
| FastvCore™ | OPTOPLANAR [®] | SuperFET™ | UniFET™ |
| FPST™ |  PDP-SPM™ | SuperSOT™-3 | VCX™ |
| FRFET [®] | Power220 [®] | SuperSOT™-6 | |
| Global Power Resource SM | | | |

DISCLAIMER

FAIRCHILD SEMICONDUCTOR RESERVES THE RIGHT TO MAKE CHANGES WITHOUT FURTHER NOTICE TO ANY PRODUCTS HEREIN TO IMPROVE RELIABILITY, FUNCTION, OR DESIGN. FAIRCHILD DOES NOT ASSUME ANY LIABILITY ARISING OUT OF THE APPLICATION OR USE OF ANY PRODUCT OR CIRCUIT DESCRIBED HEREIN; NEITHER DOES IT CONVEY ANY LICENSE UNDER ITS PATENT RIGHTS, NOR THE RIGHTS OF OTHERS. THESE SPECIFICATIONS DO NOT EXPAND THE TERMS OF FAIRCHILD'S WORLDWIDE TERMS AND CONDITIONS, SPECIFICALLY THE WARRANTY THEREIN, WHICH COVERS THESE PRODUCTS.

LIFE SUPPORT POLICY

FAIRCHILD'S PRODUCTS ARE NOT AUTHORIZED FOR USE AS CRITICAL COMPONENTS IN LIFE SUPPORT DEVICES OR SYSTEMS WITHOUT THE EXPRESS WRITTEN APPROVAL OF FAIRCHILD SEMICONDUCTOR CORPORATION.

As used herein:

1. Life support devices or systems are devices or systems which, (a) are intended for surgical implant into the body or (b) support or sustain life, and (c) whose failure to perform when properly used in accordance with instructions for use provided in the labeling, can be reasonably expected to result in a significant injury of the user.
2. A critical component in any component of a life support, device, or system whose failure to perform can be reasonably expected to cause the failure of the life support device or system, or to affect its safety or effectiveness.

PRODUCT STATUS DEFINITIONS

Definition of Terms

Datasheet Identification	Product Status	Definition
Advance Information	Formative or In Design	This datasheet contains the design specifications for product development. Specifications may change in any manner without notice.
Preliminary	First Production	This datasheet contains preliminary data; supplementary data will be published at a later date. Fairchild Semiconductor reserves the right to make changes at any time without notice to improve design.
No Identification Needed	Full Production	This datasheet contains final specifications. Fairchild Semiconductor reserves the right to make changes at any time without notice to improve design.
Obsolete	Not In Production	This datasheet contains specifications on a product that has been discontinued by Fairchild Semiconductor. The datasheet is printed for reference information only.

Rev. I31