

FSA2269 / FSA2269TS — Low-Voltage Dual-SPDT (0.4Ω) Analog Switch with Negative Swing Audio Capability

Features

- 0.4Ω Typical On Resistance (R_{ON}) for +3.0V Supply
- 0.25Ω Maximum R_{ON} Flatness for +3.0V Supply
- -3db Bandwidth: > 50MHz
- Low- I_{CCCT} Current Over an Expanded Control Input Range
- Packaged in 10-Lead MicroPak™, UMLP, and WLCSP
- Power-Off Protection on Common Ports
- Broad V_{CC} Operating Range: 1.65 to 4.5V
- Noise Immunity Termination Resistors in FSA2269TS

Applications

- Cell Phone, PDA, Digital Camera, and Notebook
- LCD Monitor, TV, and Set-Top Box

Description

The FSA2269 is a high-performance, dual Single-Pole Double-Throw (SPDT) analog switch with negative swing audio capability. The FSA2269 features ultra-low R_{ON} of 0.4Ω (typical) at 3.0V V_{CC} . The FSA2269 operates over a wide V_{CC} range of 1.65V to 4.5V, is fabricated with sub-micron CMOS technology to achieve fast switching speeds, and is designed for break-before-make operation. The select input is TTL-level compatible.

The FSA2269 features very low quiescent current even when the control voltage is lower than the V_{CC} supply. This feature suits mobile handset applications by allowing direct interface with baseband processor general-purpose I/Os with minimal battery consumption.

The FSA2269TS includes termination resistors that improve noise immunity during overshoot excursions, off-isolation coupling, or "pop-minimization."

Ordering Information

| Part Number | Top Mark | Package Description |
|---------------|----------|--|
| FSA2269L10X | HL | 10-Lead, MicroPak, JEDEC MO-255, 1.6 x 2.1mm |
| FSA2269UMX | HP | 10-Lead, Quad Ultrathin Molded Leadless Package (UMLP), 1.4 x 1.8mm, 0.4mm Pitch |
| FSA2269TSL10X | HU | 10-Lead, MicroPak, JEDEC MO-255, 1.6 x 2.1mm |
| FSA2269TSUMX | HT | 10-Lead, Quad Ultrathin Molded Leadless Package(UMLP), 1.4 x 1.8mm, 0.4mm Pitch |
| FSA2269UCX | N9 | 12-Ball, Wafer-Level Chip Scale Package (WLCSP), 1.2 x 1.6mm, 0.4mm Pitch |

Analog Symbols

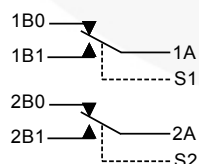

Figure 1. FSA2269

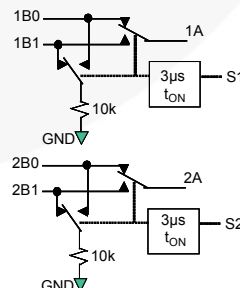

Figure 2. FSA2269TS (with Slow Turn On)

Pin Configuration

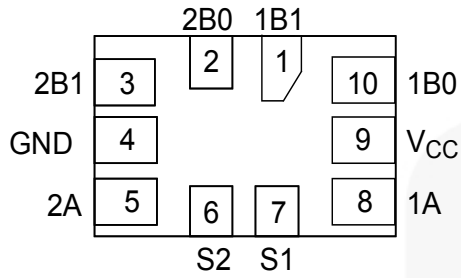

Figure 3. 10-Pin UMLP (Top Through View)

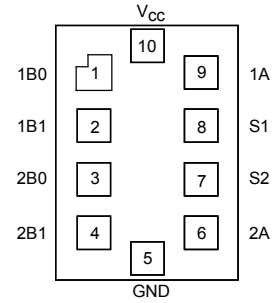

Figure 4. 10-Pin MicroPak™ (Top Through View)

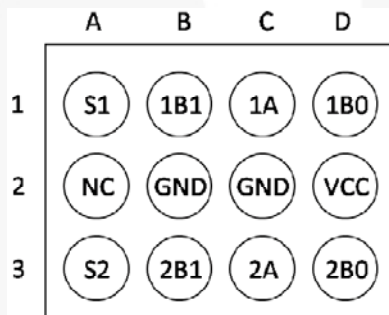

Figure 5. 12-Ball WLCSP (Bump Side View)

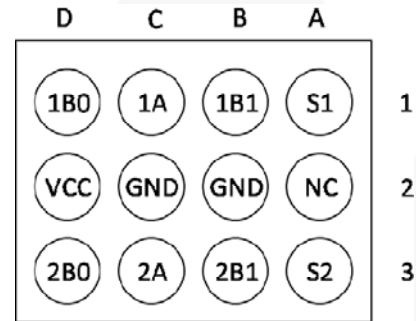

Figure 6. 12-Ball WLCSP (Top Side View)

Pin Descriptions

| Pin # UMLP | Pin # Micropak | WLCSP | Name | Description |
|------------|----------------|-------|-----------------|--------------------|
| 1 | 2 | B1 | 1B1 | Data Ports |
| 2 | 3 | D3 | 2B0 | Data Ports |
| 3 | 4 | B3 | 2B1 | Data Ports |
| 4 | 5 | B2,C2 | GND | Ground |
| 5 | 6 | C3 | 2A | Data Ports |
| 6 | 7 | A3 | S2 | Switch Select Pins |
| 7 | 8 | A1 | S1 | Switch Select Pins |
| 8 | 9 | C1 | 1A | Data Ports |
| 9 | 10 | D2 | V _{CC} | Supply Voltage |
| 10 | 1 | D1 | 1B0 | Data Ports |

Truth Table

| Control Input, S _n | Function |
|-------------------------------|--|
| LOW Logic Level | nB0 connected to nA (FSA2269/2269TS); nB1 terminated to GND (FSA2269TS only) |
| HIGH Logic Level | nB1 connected to nA (FSA2269/2269TS); nB0 terminated to GND (FSA2269TS only) |

Absolute Maximum Ratings

Stresses exceeding the absolute maximum ratings may damage the device. Functional operation above the recommended operating conditions is not implied. In addition, extended exposure to stresses above the recommended operating conditions may affect device reliability. Absolute maximum ratings are stress ratings only.

| Symbol | Parameter | | Min. | Max. | Unit |
|---------------------|--|---|----------------------|----------------------|------|
| V _{CC} | Supply Voltage | | -0.5 | 5.5 | V |
| V _{SW} | Switch I/O Voltage ⁽¹⁾ | 1B0, 1B1, 2B0, 2B1, 1A, 2A Pins | V _{CC} -4.6 | V _{CC} +0.3 | V |
| V _{CNTRL} | Control Input Voltage ⁽¹⁾ | S1, S2 | -0.5 | V _{CC} +0.3 | V |
| I _{SW} | Switch I/O Current (Continuous) | | | 350 | mA |
| I _{SWPEAK} | Peak Switch Current | Pulsed at 1ms Duration, <10% Duty Cycle | | 500 | mA |
| T _{STG} | Storage Temperature Range | | -65 | +150 | °C |
| T _J | Maximum Junction Temperature | | | +150 | °C |
| T _L | Lead Temperature | Soldering, 10 Seconds | | +260 | °C |
| MSL | Moisture Sensitivity Level, JEDEC J-STD-020A | | 1 | | |
| ESD | Human Body Model, JEDEC: JESD22-A114 | I/O to GND | | 12 | kV |
| | | I/O to GND FSA2269UCX | | 11 | |
| | | Power to GND | | 8 | |
| | | All Other Pins | | 7 | |
| | Charged Device Model, JEDEC: JESD22-C101 | | | 2 | |

Note:

- Input and output negative ratings may be exceeded if input and output diode current ratings are observed.

Recommended Operating Conditions

The Recommended Operating Conditions table defines the conditions for actual device operation. Recommended operating conditions are specified to ensure optimal performance to the datasheet specifications. Fairchild does not recommend exceeding them or designing to absolute maximum ratings.

| Symbol | Parameter | Min. | Max. | Unit |
|---------------------|-------------------------------|----------------------|-----------------|------|
| V _{CC} | Supply Voltage ⁽²⁾ | 1.65 | 4.50 | V |
| V _{S1, S2} | Control Input Voltage | 0V | V _{CC} | V |
| V _{SW} | Switch I/O Voltage | V _{CC} -4.3 | V _{CC} | V |
| T _A | Operating Temperature | -40 | +85 | °C |

Note:

- For 4.5V operation, SEL frequency (pins S1 & S2) should not exceed 100Hz and 50ns edge rate.

DC Electrical Characteristics

All typical values are $T_A=25^\circ\text{C}$ unless otherwise specified.

| Symbol | Parameter | Conditions | V_{CC} (V) | $T_A=+25^\circ\text{C}$ | | | $T_A=-40$ to $+85^\circ\text{C}$ | | Unit |
|----------------------------------|---|--|--------------|-------------------------|------|------|----------------------------------|----------|---------------|
| | | | | Min. | Typ. | Max. | Min. | Max. | |
| V_{IH} | Input Voltage High | | 3.60 to 4.50 | | | | 1.70 | | V |
| | | | 3.00 to 3.60 | | | | 1.50 | | |
| | | | 2.70 to 3.00 | | | | 1.35 | | |
| | | | 2.30 to 2.70 | | | | 1.30 | | |
| | | | 1.65 to 1.95 | | | | 0.90 | | |
| V_{IL} | Input Voltage Low | | 3.60 to 4.50 | | | | | 0.7 | V |
| | | | 2.70 to 3.60 | | | | | 0.5 | V |
| | | | 2.30 to 2.70 | | | | | 0.4 | |
| | | | 1.65 to 1.95 | | | | | 0.4 | |
| I_{IN} | Control Input Leakage (S1,S2) | $V_{IN}=0$ to V_{CC} | 1.65 to 4.50 | | | | -0.5 | 0.5 | μA |
| $I_{NO(OFF)}$, $I_{NC(OFF)}$ | Off Leakage Current of Port nB0 and nB1 (FSA2269 only) | nA=0.5V, $V_{CC}=0.5V$ nB0 or nB1= $V_{CC}-0.5V$, 0.5V, or Floating Figure 8 | 1.95 to 4.50 | -50 | | 50 | -250 | 250 | nA |
| $I_{A(ON)}$ | On Leakage Current of Port nA | nA=0.5V, $V_{CC}=0.5V$ nB0 or nB1= $V_{CC}-0.5V$, 0.5V, or Floating Figure 9 | 1.95 to 4.50 | -20 | | 20 | -150 | 150 | nA |
| I_{OFF} | Power-Off Leakage Current (Common Port Only 1A, 2A) (FSA2269) | Common Port (1A, 2A), $V_{IN}=0V$ to 4.5V, $V_{CC}=0V$ nB0, nB1=Floating | 0 | | | | | ± 1 | μA |
| | Power-Off Leakage Current (Common Port Only 1A, 2A) (FSA2269TS) | Common Port (1A, 2A), $V_{IN}=0V$ to 4.5V, $V_{CC}=0V$ nB0, nB1=0V or Floating | 0 | | | | | ± 45 | μA |
| R_{ON} | Switch On Resistance ^(3,6) | $I_{ON}=100\text{mA}$, nB0 or nB1=0.7V, 3.6V, 4.5V Figure 7 | 4.50 | | 0.30 | | | | Ω |
| | | $I_{ON}=100\text{mA}$, nB0 or nB1=0.7V, 3.6V, Figure 7 | 3.00 | | 0.40 | | | 0.80 | |
| | | $I_{ON}=100\text{mA}$, nB0 or nB1=0V, 0.7V, 1.6V, 2.3V, Figure 7 | 2.30 | | 0.52 | | | | |
| | | $I_{ON}=100\text{mA}$, nB0 or nB1=0V, 0.7V, 1.65V Figure 7 | 1.65 | | 1.00 | | | | |
| ΔR_{ON} | On Resistance Matching Between Channels ⁽⁴⁾ | $I_{ON}=100\text{mA}$, nB0 or nB1=0.7V | 4.50 | | 0.04 | | | 0.13 | Ω |
| | | | 3.00 | | 0.06 | | | 0.13 | |
| | | | 2.30 | | 0.12 | | | | |
| | | | 1.65 | | 1.00 | | | | |

Continued on the following page...

DC Electrical Characteristics (Continued)

All typical values are $T_A=25^\circ\text{C}$ unless otherwise specified.

| Symbol | Parameter | Conditions | V_{CC} (V) | $T_A=+25^\circ\text{C}$ | | | $T_A=-40$ to $+85^\circ\text{C}$ | | Unit |
|-----------------------|--|---|--------------|-------------------------|------|------|----------------------------------|------|---------------|
| | | | | Min. | Typ. | Max. | Min. | Max. | |
| $R_{\text{FLAT(ON)}}$ | On Resistance Flatness ⁽⁵⁾ | $I_{\text{OUT}}=100\text{mA}$, nB0 or nB1=0V to V_{CC} | 4.50 | | | | | 0.25 | Ω |
| | | | 3.00 | | | | | 0.25 | |
| | | | 2.30 | | 0.5 | | | | |
| | | | 1.65 | | 0.6 | | | | |
| R_{TERM} | Internal Termination Resistors ⁽⁶⁾ (FSA2269TS only) | | | | 10 | | | | k Ω |
| I_{CC} | Quiescent Supply Current | $V_{\text{IN}}=0$ or V_{CC} , $I_{\text{OUT}}=0$ | 4.50 | -100 | | 100 | -500 | 500 | nA |
| I_{CCT} | Increase in I_{CC} per Input | Input at 2.6V | 4.50 | | 3.0 | | | 10.0 | μA |
| | | Input at 1.8V | | | 7.0 | | | 15.0 | |

Notes:

3. On resistance is determined by the voltage drop between A and B pins at the indicated current through the switch.
4. $\Delta R_{\text{ON}}=R_{\text{ON max}} - R_{\text{ON min}}$ measured at identical V_{CC} , temperature, and voltage.
5. Flatness is defined as the difference between the maximum and minimum value of on resistance (R_{ON}) over the specified range of conditions.
6. Guaranteed by characterization, not production tested.

AC Electrical Characteristics

All typical value are $T_A=25^\circ\text{C}$ unless otherwise specified.

| Symbol | Parameter | Conditions | V_{CC} (V) | $T_A=+25^\circ\text{C}$ | | | $T_A=-40$ to $+85^\circ\text{C}$ | | Unit | Figure |
|-----------|---|--|--------------|-------------------------|------|------|----------------------------------|---------------|---------------|------------------------|
| | | | | Min. | Typ. | Max. | Min. | Max. | | |
| t_{ON} | Turn-On Time FSA2269 | nB0 or nB1=1.5V, $R_L=50\Omega$, $C_L=35\text{pF}$ | 3.60 to 4.50 | | | 55 | 15 | 60 | ns | Figure 10 Figure 11 |
| | | | 2.70 to 3.60 | | | 60 | 15 | 65 | | |
| | | | 2.30 to 2.70 | | | 100 | 15 | 110 | | |
| | | | 1.65 to 1.95 | | 70 | | | | | |
| | Turn-On Time FSA2269UCX | nB0 or nB1=1.5V, $R_L=50\Omega$, $C_L=35\text{pF}$ | 3.60 to 4.50 | | | 105 | 15 | 110 | ns | Figure 10 Figure 11 |
| | | | 2.70 to 3.60 | | | 115 | 15 | 150 | | |
| | | | 2.30 to 2.70 | | | 180 | 15 | 185 | | |
| | | | 1.65 to 1.95 | | 110 | | | | | |
| | Turn-On Time FSA2269TS | nB0 or nB1=1.5V, $R_L=50\Omega$, $C_L=35\text{pF}$ | 3.60 to 4.50 | | | 3.5 | 0.5 | 4.0 | μs | Figure 10 Figure 11 |
| | | | 2.70 to 3.60 | | | 4.5 | 0.5 | 5.0 | | |
| | | | 2.30 to 2.70 | | | 6.0 | 0.5 | 7.0 | | |
| | | | 1.65 to 1.95 | | 8.0 | | | | | |
| t_{OFF} | Turn-Off Time FSA2269 | nB0 or nB1=1.5V, $R_L=50\Omega$, $C_L=35\text{pF}$ | 3.60 to 4.50 | | | 50 | 5 | 55 | ns | Figure 10 Figure 11 |
| | | | 2.70 to 3.60 | | | 55 | 5 | 60 | | |
| | | | 2.30 to 2.70 | | | 60 | 5 | 65 | | |
| | | | 1.65 to 1.95 | | 40 | | | | | |
| | Turn-Off Time FSA2269UCX | nB0 or nB1=1.5V, $R_L=50\Omega$, $C_L=35\text{pF}$ | 3.60 to 4.50 | | | 100 | 5 | 105 | ns | Figure 10 Figure 11 |
| | | | 2.70 to 3.60 | | | 110 | 5 | 115 | | |
| | | | 2.30 to 2.70 | | | 120 | 5 | 125 | | |
| | | | 1.65 to 1.95 | | 80 | | | | | |
| | Turn-Off Time FSA2269TS | nB0 or nB1=1.5V, $R_L=50\Omega$, $C_L=35\text{pF}$ | 3.60 to 4.50 | | | 45 | 5 | 50 | ns | Figure 10 Figure 11 |
| | | | 2.70 to 3.60 | | | 50 | 5 | 55 | | |
| | | | 2.30 to 2.70 | | | 55 | 5 | 60 | | |
| | | | 1.65 to 1.95 | | 50 | | | | | |
| t_{BBM} | Break-Before- Make Time FSA2269 ⁽⁷⁾ | nB0 or nB1=1.5V, $R_L=50\Omega$, $C_L=35\text{pF}$ | 3.60 to 4.50 | | 3 | | 1 | ns | Figure 12 | |
| | | | 2.70 to 3.60 | | 5 | | 2 | | | |
| | | | 2.30 to 2.70 | | 10 | | 2 | | | |
| | | | 1.65 to 1.95 | | 5 | | 2 | | | |
| t_{BBM} | Break-Before- Make Time FSA2269UCX ⁽⁷⁾ | nB0 or nB1=1.5V, $R_L=50\Omega$, $C_L=35\text{pF}$ | 3.60 to 4.50 | | 9.5 | | 5.5 | ns | Figure 12 | |
| | | | 2.70 to 3.60 | | 17.0 | | 15.0 | | | |
| | | | 2.30 to 2.70 | | 22.0 | | 20.0 | | | |
| | | | 1.65 to 1.95 | | 46.0 | | 41.0 | | | |
| t_{BBM} | Break-Before- Make Time FSA2269TS ⁽⁷⁾ | nB0 or nB1=1.5V, $R_L=50\Omega$, $C_L=35\text{pF}$ | 3.60 to 4.50 | | 1.5 | | 1.0 | μs | Figure 12 | |
| | | | 2.70 to 3.60 | | 3.0 | | 1.5 | | | |
| | | | 2.30 to 2.70 | | 4.0 | | 2.5 | | | |
| | | | 1.65 to 1.95 | | 5.0 | | 3.0 | | | |

Continued on the following page...

AC Electrical Characteristics (Continued)

All typical values are $T_A=25^\circ\text{C}$ unless otherwise specified.

| Symbol | Parameter | Conditions | V_{CC} (V) | $T_A=+25^\circ\text{C}$ | | | $T_A=-40$ to $+85^\circ\text{C}$ | | Unit | Figure |
|--------|---------------------------|---|--------------|-------------------------|------|------|----------------------------------|------|------|-----------|
| | | | | Min. | Typ. | Max. | Min. | Max. | | |
| Q | Charge Injection | $C_L=1.0\text{nF}$, $V_S=0\text{V}$, $R_S=0\Omega$ | 1.65 to 4.50 | | 25 | | | | pC | Figure 16 |
| OIRR | Off Isolation | $f=100\text{kHz}$, $R_L=50\Omega$, $C_L=0\text{pF}$ | 1.65 to 4.50 | | -70 | | | | dB | Figure 14 |
| Xtalk | Crosstalk | $f=100\text{kHz}$, $R_L=50\Omega$, $C_L=0\text{pF}$ | 1.65 to 4.50 | | -70 | | | | dB | Figure 15 |
| BW | -3db Bandwidth | $R_L=50\Omega$, $C_L=0\text{pF}$ | 1.65 to 4.50 | | >50 | | | | MHz | Figure 13 |
| THD | Total Harmonic Distortion | $f=20\text{Hz}$ to 20kHz , $R_L=32\Omega$, $V_{IN}=2V_{PP}$, $V_{BIAS}=0\text{V}$ | 1.65 to 4.50 | | .06 | | | | % | Figure 19 |

Notes:

- Guaranteed by characterization, not production tested.

Capacitance

| Symbol | Parameter | Conditions | V_{CC} (V) | $T_A=+25^\circ\text{C}$ | | | Unit | Figure |
|-----------|-------------------------------|-----------------|--------------|-------------------------|------|------|------|-----------|
| | | | | Min. | Typ. | Max. | | |
| C_{IN} | Control Pin Input Capacitance | $f=1\text{MHz}$ | 0 | | 2.5 | | pF | Figure 17 |
| C_{OFF} | B Port Off Capacitance | $f=1\text{MHz}$ | 3.3 | | 30 | | pF | Figure 17 |
| C_{ON} | A Port On Capacitance | $f=1\text{MHz}$ | 3.3 | | 120 | | pF | Figure 18 |

Test Diagrams

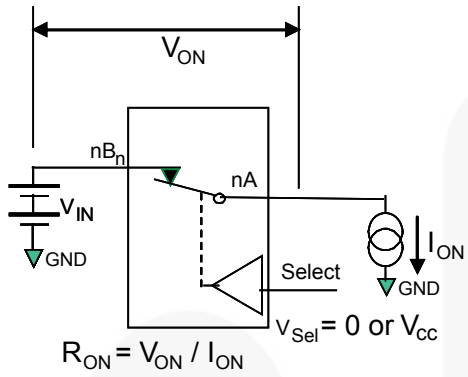

Figure 7. On Resistance

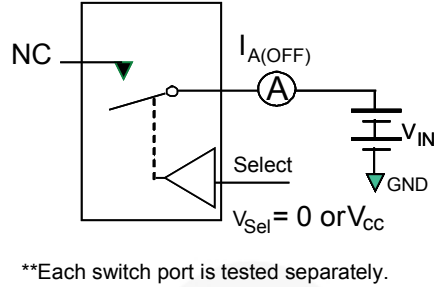

Figure 8. Off Leakage

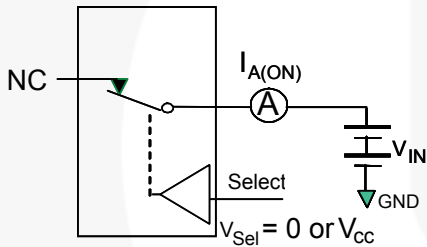

Figure 9. On Leakage

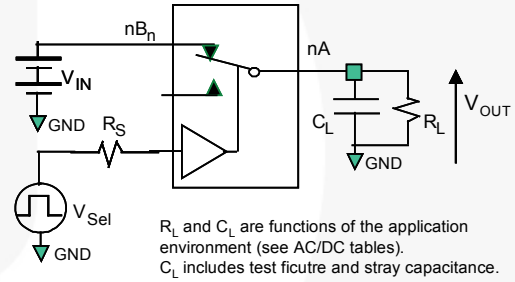

Figure 10. Test Circuit Load

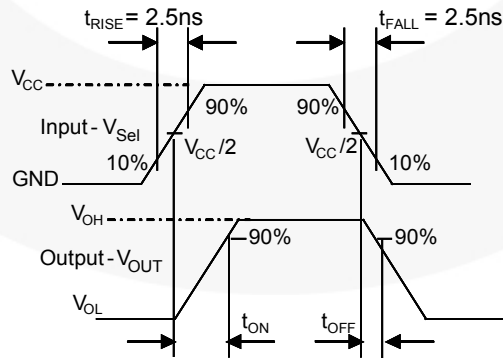

Figure 11. Turn-On / Turn-Off Waveforms

Test Diagrams (Continued)

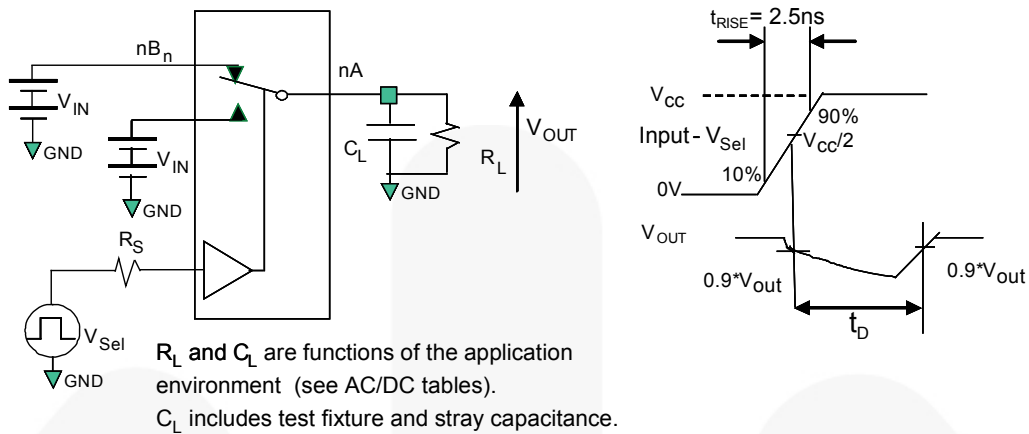

Figure 12. Break-Before-Make Interval Timing

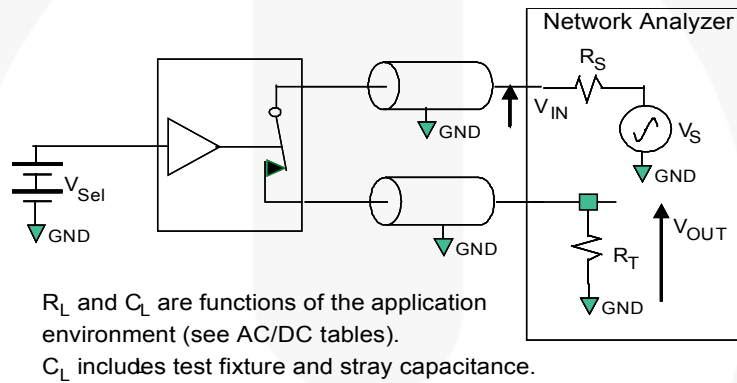

Figure 13. Bandwidth

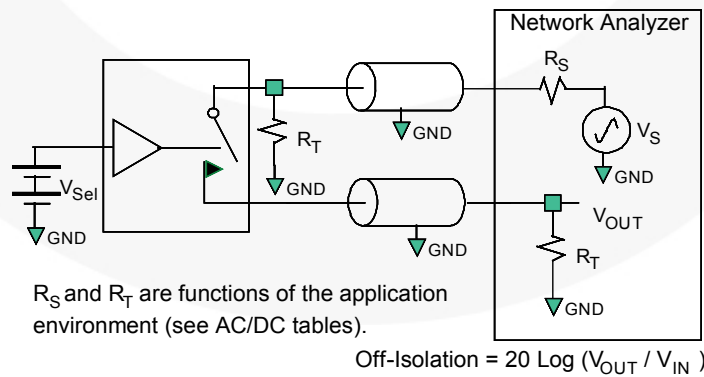

Figure 14. Channel Off Isolation

Test Diagrams (Continued)

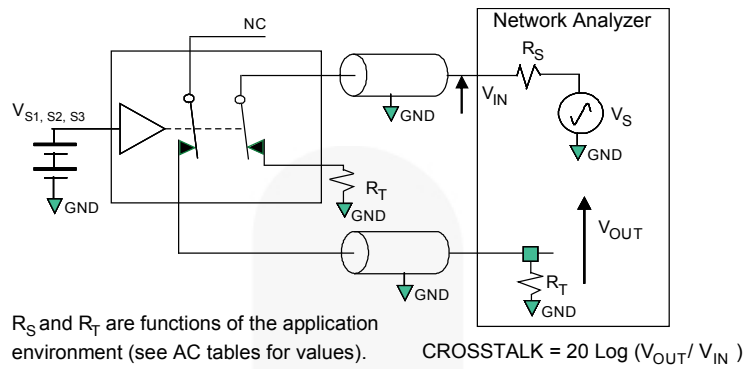

Figure 15. Adjacent Channel Crosstalk

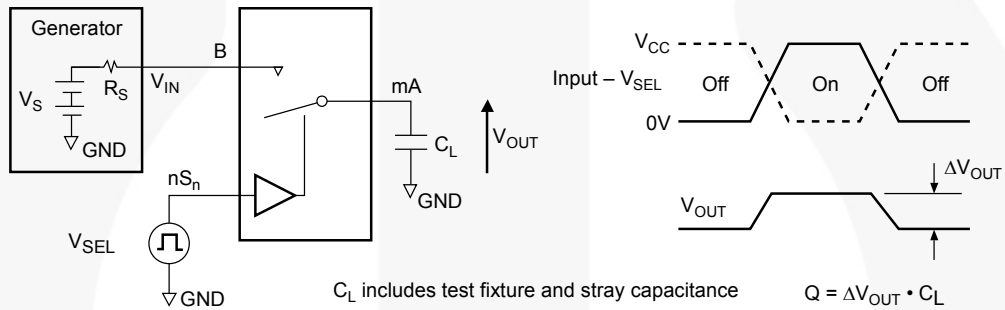

Figure 16. Charge Injection Test

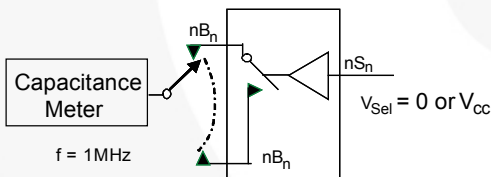

Figure 17. Channel Off Capacitance

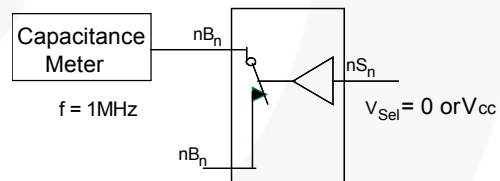

Figure 18. Channel On Capacitance

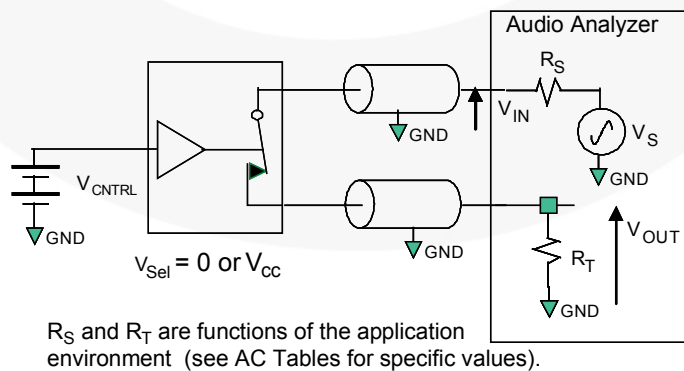

Figure 19. Total Harmonic Distortion

Physical Dimensions

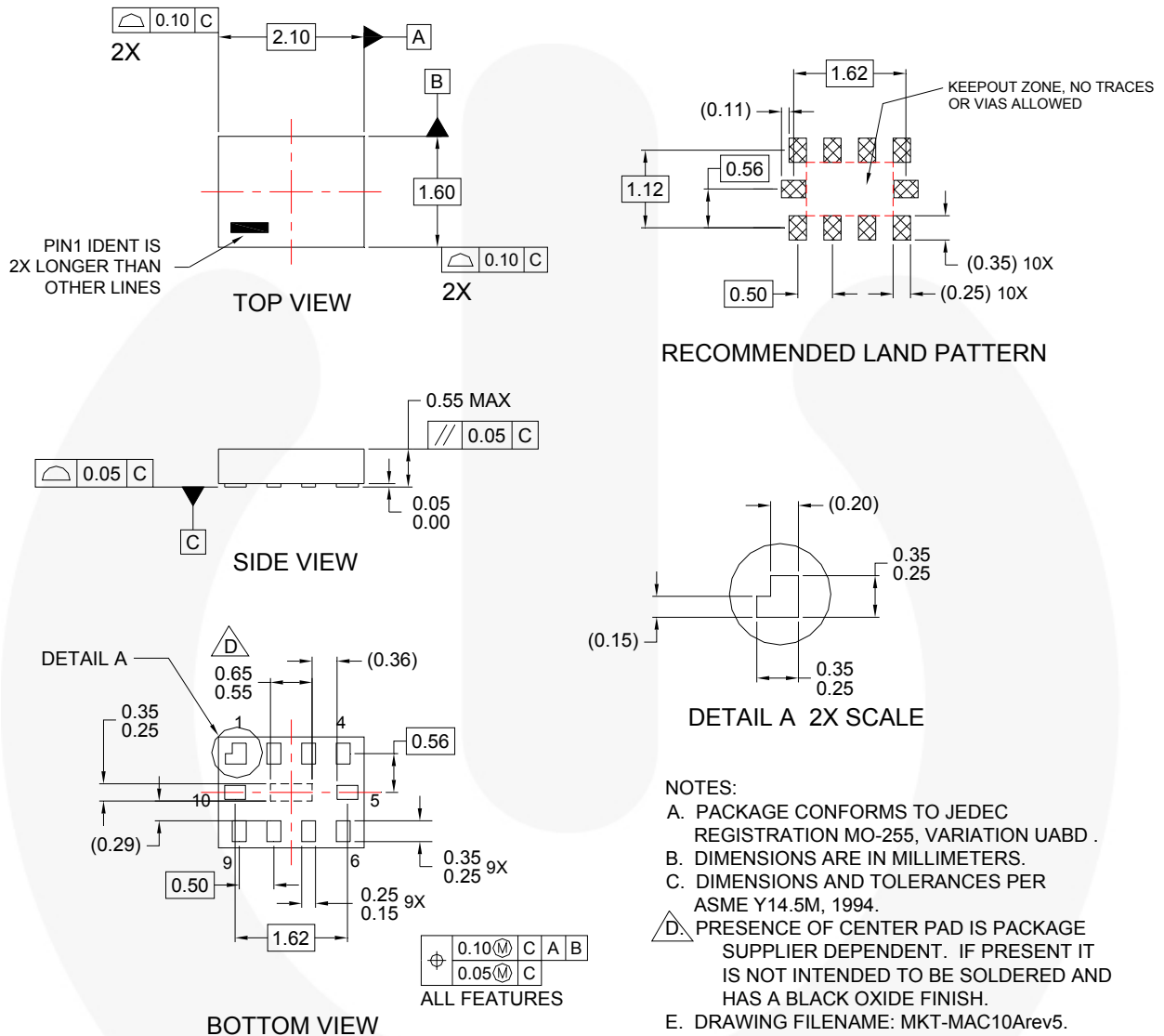
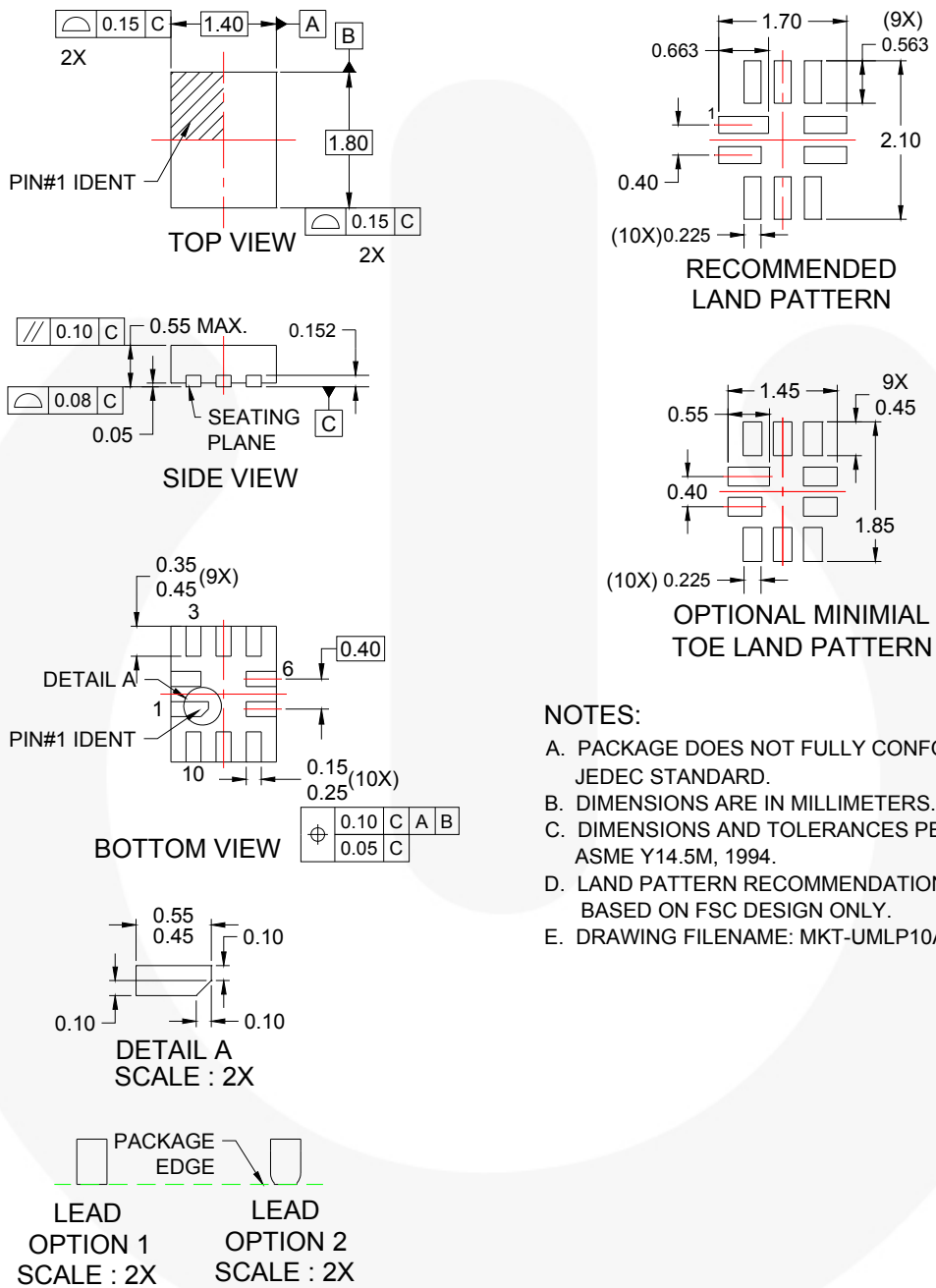

Figure 20. 10-Lead MicroPak™

Package drawings are provided as a service to customers considering Fairchild components. Drawings may change in any manner without notice. Please note the revision and/or date on the drawing and contact a Fairchild Semiconductor representative to verify or obtain the most recent revision. Package specifications do not expand the terms of Fairchild's worldwide terms and conditions, specifically the warranty therein, which covers Fairchild products.

Always visit Fairchild Semiconductor's online packaging area for the most recent package drawings:
<http://www.fairchildsemi.com/packaging/>

Physical Dimensions (Continued)



NOTES:

- A. PACKAGE DOES NOT FULLY CONFORM TO JEDEC STANDARD.
- B. DIMENSIONS ARE IN MILLIMETERS.
- C. DIMENSIONS AND TOLERANCES PER ASME Y14.5M, 1994.
- D. LAND PATTERN RECOMMENDATION IS BASED ON FSC DESIGN ONLY.
- E. DRAWING FILENAME: MKT-UMLP10Arev3.

Figure 21. 10-Lead, Quad Ultrathin Molded Leadless Package (UMLP)

Package drawings are provided as a service to customers considering Fairchild components. Drawings may change in any manner without notice. Please note the revision and/or date on the drawing and contact a Fairchild Semiconductor representative to verify or obtain the most recent revision. Package specifications do not expand the terms of Fairchild's worldwide terms and conditions, specifically the warranty therein, which covers Fairchild products.

Always visit Fairchild Semiconductor's online packaging area for the most recent package drawings:

<http://www.fairchildsemi.com/packaging/>

Physical Dimensions (Continued)

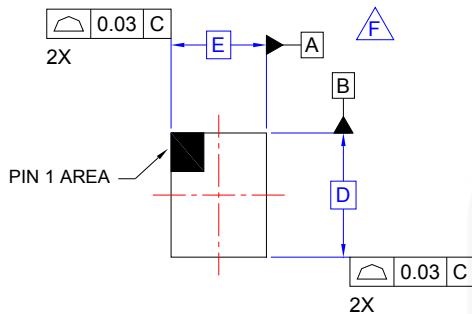

TOP VIEW

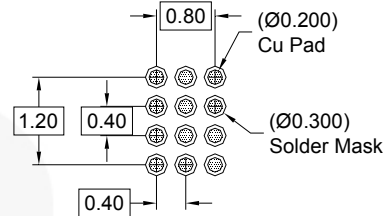

RECOMMENDED LAND PATTERN
(NSMD PAD TYPE)

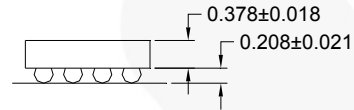
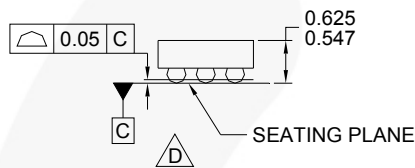

SIDE VIEWS

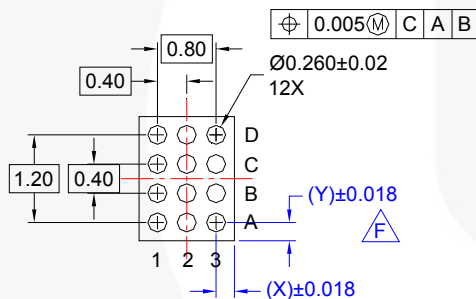

BOTTOM VIEW

NOTES:

- A. NO JEDEC REGISTRATION APPLIES.
- B. DIMENSIONS ARE IN MILLIMETERS.
- C. DIMENSIONS AND TOLERANCES PER ASME Y14.5M, 1994.
- D. DATUM C IS DEFINED BY THE SPHERICAL CROWNS OF THE BALLS.
- E. PACKAGE NOMINAL HEIGHT IS 586 MICRONS ±39 MICRONS (547-625 MICRONS).
- F. FOR DIMENSIONS D, E, X, AND Y SEE PRODUCT DATASHEET.
- G. DRAWING FILENAME: MKT-UC012ACrev1.

Product-Specific Dimensions

| Product | D | E | X | Y |
|------------|---------|---------|---------|---------|
| FSA2269UCX | 1.560mm | 1.160mm | 0.180mm | 0.180mm |

Figure 22. 12-Ball, Wafer Level Chip-Scale Package (WLCSP)

Package drawings are provided as a service to customers considering Fairchild components. Drawings may change in any manner without notice. Please note the revision and/or date on the drawing and contact a Fairchild Semiconductor representative to verify or obtain the most recent revision. Package specifications do not expand the terms of Fairchild's worldwide terms and conditions, specifically the warranty therein, which covers Fairchild products.

Always visit Fairchild Semiconductor's online packaging area for the most recent package drawings:
<http://www.fairchildsemi.com/packaging/>



TRADEMARKS

The following includes registered and unregistered trademarks and service marks, owned by Fairchild Semiconductor and/or its global subsidiaries, and is not intended to be an exhaustive list of all such trademarks.

- | | | | |
|--|--|--|--|
| 2Cool™ | F-PFS™ | PowerTrench® | The Power Franchise® |
| AccuPower™ | FRFET® | PowerXS™ | the power franchise |
| AX-CAP™* | Global Power Resource™ | Programmable Active Droop™ | TinyBoost™ |
| BitSiC™ | GreenBridge™ | QFET® | TinyBuck™ |
| Build it Now™ | Green FPS™ | QS™ | TinyCalc™ |
| CorePLUS™ | Green FPS™ e-Series™ | Quiet Series™ | TinyLogic® |
| CorePOWER™ | Gmax™ | RapidConfigure™ | TINYOPTO™ |
| CROSSVOL7™ | GTO™ |  ™ | TinyPower™ |
| CTL™ | IntelliMAX™ | Saving our world, 1mW/W/kW at a time™ | TinyPWM™ |
| Current Transfer Logic™ | ISOPLANAR™ | SignalWise™ | TinyWire™ |
| DEUXPEED® | Making Small Speakers Sound Louder and Better™ | SmartMax™ | TranSiC™ |
| Dual Cool™ | MegaBuck™ | SMART START™ | TriFault Detect™ |
| EcoSPARK® | MICROCOUPLER™ | Solutions for Your Success™ | TRUECURRENT®* |
| EfficientMax™ | MicroFET™ | SPM® | µSerDes™ |
| ESBC™ | MicroPak™ | STEALTH™ |  SerDes |
|  Fairchild® | MicroPak2™ | SuperFET® | UHC® |
| Fairchild Semiconductor® | MillerDrive™ | SuperSOT™-3 | Ultra FRFET™ |
| FACT Quiet Series™ | MotionMax™ | SuperSOT™-6 | UniFET™ |
| FACT® | Motion-SPM™ | SuperSOT™-8 | VCC™ |
| FAST® | mWSaver™ | SupreMOS® | VisualMax™ |
| FastvCore™ | OptoHi™ | SyncFET™ | VoltagePlus™ |
| FETBench™ | OPTOLOGIC® | Sync-Lock™ | XS™ |
| FlashWriter®* | OPTOPLANAR® |  SYSTEM GENERAL®* | |
| FPS™ | | | |

* Trademarks of System General Corporation, used under license by Fairchild Semiconductor.

DISCLAIMER

FAIRCHILD SEMICONDUCTOR RESERVES THE RIGHT TO MAKE CHANGES WITHOUT FURTHER NOTICE TO ANY PRODUCTS HEREIN TO IMPROVE RELIABILITY, FUNCTION, OR DESIGN. FAIRCHILD DOES NOT ASSUME ANY LIABILITY ARISING OUT OF THE APPLICATION OR USE OF ANY PRODUCT OR CIRCUIT DESCRIBED HEREIN; NEITHER DOES IT CONVEY ANY LICENSE UNDER ITS PATENT RIGHTS, NOR THE RIGHTS OF OTHERS. THESE SPECIFICATIONS DO NOT EXPAND THE TERMS OF FAIRCHILD'S WORLDWIDE TERMS AND CONDITIONS, SPECIFICALLY THE WARRANTY THEREIN, WHICH COVERS THESE PRODUCTS.

LIFE SUPPORT POLICY

FAIRCHILD'S PRODUCTS ARE NOT AUTHORIZED FOR USE AS CRITICAL COMPONENTS IN LIFE SUPPORT DEVICES OR SYSTEMS WITHOUT THE EXPRESS WRITTEN APPROVAL OF FAIRCHILD SEMICONDUCTOR CORPORATION.

As used herein:

1. Life support devices or systems are devices or systems which, (a) are intended for surgical implant into the body or (b) support or sustain life, and (c) whose failure to perform when properly used in accordance with instructions for use provided in the labeling, can be reasonably expected to result in a significant injury of the user.
2. A critical component in any component of a life support, device, or system whose failure to perform can be reasonably expected to cause the failure of the life support device or system, or to affect its safety or effectiveness.

ANTI-COUNTERFEITING POLICY

Fairchild Semiconductor Corporation's Anti-Counterfeiting Policy. Fairchild's Anti-Counterfeiting Policy is also stated on our external website, www.fairchildsemi.com, under Sales Support.

Counterfeiting of semiconductor parts is a growing problem in the industry. All manufacturers of semiconductor products are experiencing counterfeiting of their parts. Customers who inadvertently purchase counterfeit parts experience many problems such as loss of brand reputation, substandard performance, failed applications, and increased cost of production and manufacturing delays. Fairchild is taking strong measures to protect ourselves and our customers from the proliferation of counterfeit parts. Fairchild strongly encourages customers to purchase Fairchild parts either directly from Fairchild or from Authorized Fairchild Distributors who are listed by country on our web page cited above. Products customers buy either from Fairchild directly or from Authorized Fairchild Distributors are genuine parts, have full traceability, meet Fairchild's quality standards for handling and storage and provide access to Fairchild's full range of up-to-date technical and product information. Fairchild and our Authorized Distributors will stand behind all warranties and will appropriately address any warranty issues that may arise. Fairchild will not provide any warranty coverage or other assistance for parts bought from Unauthorized Sources. Fairchild is committed to combat this global problem and encourage our customers to do their part in stopping this practice by buying direct or from authorized distributors.

PRODUCT STATUS DEFINITIONS

Definition of Terms

| Datasheet Identification | Product Status | Definition |
|--------------------------|-----------------------|---|
| Advance Information | Formative / In Design | Datasheet contains the design specifications for product development. Specifications may change in any manner without notice. |
| Preliminary | First Production | Datasheet contains preliminary data; supplementary data will be published at a later date. Fairchild Semiconductor reserves the right to make changes at any time without notice to improve design. |
| No Identification Needed | Full Production | Datasheet contains final specifications. Fairchild Semiconductor reserves the right to make changes at any time without notice to improve the design. |
| Obsolete | Not In Production | Datasheet contains specifications on a product that is discontinued by Fairchild Semiconductor. The datasheet is for reference information only. |

Rev. 161