

FSA2156

Low-Voltage SPST 0.4Ω Analog Switch

Features

- Maximum 0.7Ω On Resistance (R_{ON}) for +2.7V Supply
- 0.25Ω Maximum R_{ON} Flatness for +2.7V Supply
- Space-Saving MicroPak™ and SC70 Packaging
- Broad V_{CC} Operating Range: 1.65 to 4.3V
- Fast Turn-on and Turn-off Times
- Over-Voltage Tolerant TTL-Compatible Control Input
- Suitable for 2 UL USB2.0 Applications: 200mA
- Low I_{CCT} Current Over Expanded Control Input Range

Description

The FSA2156 is a high-performance Single-Pole Single-Throw (SPST) analog switch that features ultra low R_{ON} of 0.4Ω (typical) at 2.7V V_{CC} . The FSA2156 operates over the wide V_{CC} range of 1.65V to 4.3V and is fabricated with sub-micron CMOS technology to achieve fast switching speeds. The select input is TTL-level compatible.

FSA2156 features very low quiescent current even when the control voltage is lower than the V_{CC} supply. This feature facilitates longer battery life in mobile handset applications and allows for the direct interface with baseband-processor, general-purpose I/Os.

Ordering Information

Part Number	Top Mark	Package Description	Packing Method
FSA2156P6X	256	6-lead SC70, EIAJ SC88, 1.25mm Wide	3000 Units on Tape and Reel
FSA2156L6X	FY	6-lead MicroPak™, 1.0mm Wide	5000 Units on Tape and Reel
FSA2156FHX	FY	6-Lead, MicroPak2™, 1x1mm Body, .35mm Pitch	5000 Units on Tape and Reel

Pin Configurations

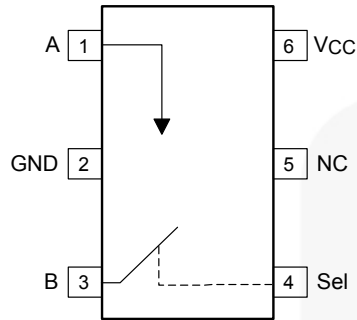

Figure 1. SC70 Pin Assignments (Top View)

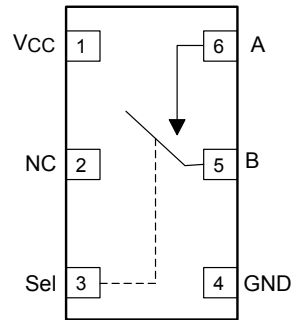

Figure 2. MicroPak™ Pin Assignments (Top View)

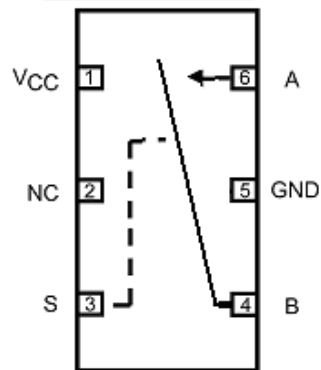

Figure 3. MicroPak2™ Pin Assignments (Top View)

Pin Definitions

Pin # SC70	Pin # MicroPak™	Pin # MicroPak2™	Name	Description
1	6	6	A	Switch I/O Data Ports
2	4	5	GND	Ground
3	5	4	B	Switch I/O Data Ports
4	3	3	Sel	Control Input
5	2	2	NC	No Connect
6	1	1	V _{CC}	Supply Voltage

Truth Table

Control Input (S)	Function
Logic Level LOW	Switch Open (OFF)
Logic Level HIGH	Switch Closed (ON)

Absolute Maximum Ratings

Stresses exceeding the absolute maximum ratings may damage the device. The device may not function or be operable above the recommended operating conditions and stressing the parts to these levels is not recommended. In addition, extended exposure to stresses above the recommended operating conditions may affect device reliability. The absolute maximum ratings are stress ratings only.

Symbol	Parameter		Min.	Max.	Unit
V _{CC}	Supply Voltage		-0.5	4.6	V
V _{SW}	Switch I/O Voltage ⁽¹⁾		-0.5	V _{CC} + 0.3	V
V _{CNTRL}	Control Input Voltage ⁽¹⁾		-0.5	4.6	V
I _{IK}	Input Clamp Diode Current		± 50	± 50	mA
I _{SW}	Switch I/O Current (Continuous)			500	mA
I _{SWPEAK}	Pulsed at 1ms Duration, <10% Duty Cycle			500	mA
P _D	Power Dissipation at 85°C	SC70 Package		180	mW
		MicroPak™ Package		180	mW
T _{STG}	Storage Temperature Range		-65	+150	°C
T _J	Maximum Junction Temperature			+150	°C
T _L	Lead Temperature (Soldering, 10 seconds)			+260	°C
ESD	Electrostatic Discharge Capability	Human Body Model, JEDEC:JESD22-A114	All Pins	2	kV
			I/O to GND	8	kV
		Charge Discharge Model, JEDEC:JESD22-C101	2	kV	

Note:

- The input and output negative ratings may be exceeded if the input and output diode current ratings are observed.

Recommended Operating Conditions

The Recommended Operating Conditions table defines the conditions for actual device operation. Recommended operating conditions are specified to ensure optimal performance to the datasheet specifications. Fairchild does not recommend exceeding them or designing to absolute maximum ratings.

Symbol	Parameter		Min.	Max.	Unit
V _{CC}	Supply Voltage		1.65	4.30	V
V _{CNTRL}	Control Input Voltage ⁽²⁾		0	V _{CC}	V
V _{SW}	Switch I/O Voltage		0	V _{CC}	V
I _{SW}	Switch I/O Load Current			350	mA
T _A	Operating Temperature		-40	+85	°C
θ _{JA}	Thermal Resistance (free air)	SC70 6L Package		350	°C/W
		MicroPak™ 6L Package		310	°C/W

Note:

- Control input must be held HIGH or LOW; it must not float.

DC Electrical Characteristics

All typical values are at 25°C unless otherwise specified.

Symbol	Parameter	Condition	V _{CC} (V)	T _A =+25°C			T _A =-40 to +85°C		Unit
				Min.	Typ.	Max.	Min.	Max.	
V _{IH}	Input Voltage High		3.6 to 4.3				1.4		V
			2.7 to 3.6				1.3		
			2.3 to 2.7				1.1		
			1.65 to 1.95				0.9		
V _{IL}	Input Voltage Low		3.6 to 4.3					0.7	V
			2.7 to 3.6					0.5	V
			2.3 to 2.7					0.4	
			1.65 to 1.95					0.4	
I _{IN}	Control Input Leakage	V _{CNTRL} =0 to V _{CC}	1.65 to 4.3				-0.5	0.5	μA
I _{NO(OFF)}	Off Leakage Current of Port B	V _A =0.3V, V _{CC} - 0.3V, V _B =0.3V, V _{CC} - 0.3V or Floating, Figure 5	1.95 to 4.3	-10		10	-50	50	nA
I _{A(ON)}	On Leakage Current of Port A	V _A =0.3V, V _{CC} - 0.3V, V _B =Floating, Figure 6	1.95 to 4.3	-20		20	-100	100	nA
I _{OFF}	Power Off Leakage Current	Port A V _A =0.3V, 4.3V, V _{CC} =0V, V _B =0V	0V					±25	μA
	Power Off Leakage Current ⁽³⁾	Port A V _A =0.3V, 4.3V, V _{CC} =0V, V _B =Floating	0V	-4		+4	-35	35	nA
R _{ON}	Switch On Resistance ⁽⁴⁾ Figure 4	I _{ON} =100mA, V _B =0V, 0.7V, 3.6V and 4.3V	4.3		0.36			0.60	Ω
		I _{ON} =100mA, V _B =0V, 0.7V, 2.0V and 2.7V	2.7		0.40		0.70		
		I _{ON} =100mA, V _B =0V, 0.7V, 1.6V and 2.3V	2.3		0.55		0.80		
		I _{ON} =100mA, V _B =0.7V	1.65		1.50				
R _{FLAT(ON)}	On Resistance Flatness ⁽⁵⁾ Figure 4	I _{ON} =100mA, V _B =0V, 0.7V, 3.6V and 4.3V	4.3					0.25	Ω
		I _{ON} =100mA, V _B =0V, 0.7V, 2.0V and 2.7V	2.7				0.25		
		I _{ON} =100mA, B=0V, 0.7V, 1.6V and 2.3V	2.3				0.30		
		I _{ON} =100mA, V _B =0V, 0.7V, 0.9V and 1.65V	1.65		0.90				
I _{CC}	Quiescent Supply Current	V _{SW} =0 or V _{CC} , I _{OUT} =0	4.3	-100	30	100	-500	500	nA
I _{CC(T)}	Increase in I _{CC} per Input	V _{CNTRL} =2.6V	4.3		3			6	μA
		V _{CNTRL} =1.8V			7	12		15	

Notes:

- Guaranteed by characterization; not production tested.
- On resistance is determined by the voltage drop between A and B pins at the indicated current through the switch.
- Flatness is defined as the difference between the maximum and minimum value of on resistance over the specified range of conditions.

AC Electrical Characteristics

All typical values are at 25°C unless otherwise specified.

Symbol	Parameter	Condition	V _{CC} (V)	T _A =+25°C			T _A =-40°C to +85°C		Unit	Figure
				Min.	Typ.	Max.	Min.	Max.		
t _{ON}	Turn-On Time	V _B =1.5V, R _L =50Ω, C _L =35pF	3.6 to 4.3			55		60	ns	Figure 7 Figure 8
			2.7 to 3.6			60		65		
			2.3 to 2.7			65		70		
			1.65 to 1.95		40					
t _{OFF}	Turn-Off Time	V _B =1.5V, R _L =50Ω, C _L =35pF	3.6 to 4.3			65		70	ns	Figure 7 Figure 8
			2.7 to 3.6			70		75		
			2.3 to 2.7			75		80		
			1.65 to 1.95		90					
Q	Charge Injection	C _L =1.0nF, V _S =0V, R _S =0Ω	2.3 to 4.3		6			pC	Figure 11	
			1.65 to 1.95		1.3					
OIRR	Off Isolation	f=100kHz R _T =50Ω	1.65 to 4.3		-65			dB	Figure 10	
BW	-3db Bandwidth	R _T =50Ω C _L =0pF	1.65 to 4.3		80			MHz	Figure 9	
THD	Total Harmonic Distortion	R _T =600Ω, V _{SW} =0.5V _{PP} , f=20Hz to 20kHz	1.65 to 4.3		.02			%		

Capacitance

Symbol	Parameter	Condition	V _{CC} (V)	T _A =+25°C			Unit	Figures
				Min.	Typ.	Max.		
C _{IN}	Control Pin Input Capacitance	f=1MHz	0		1.5		pF	Figure 12
C _{OFF}	B-Port Off Capacitance	f=1MHz	4.3		38		pF	Figure 12
C _{ON}	A-Port On Capacitance	f=1MHz	4.3		115		pF	Figure 13

Test Diagrams

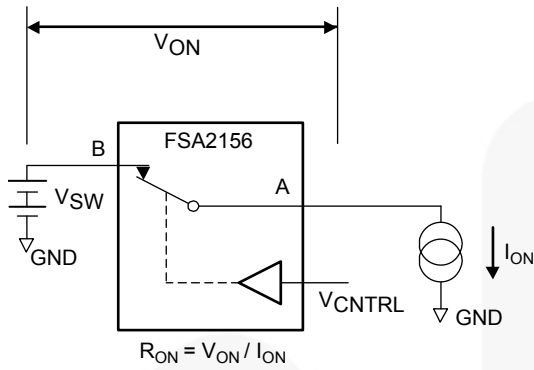

Figure 4. On Resistance

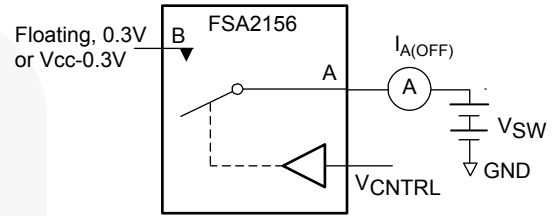

Figure 5. Off Leakage

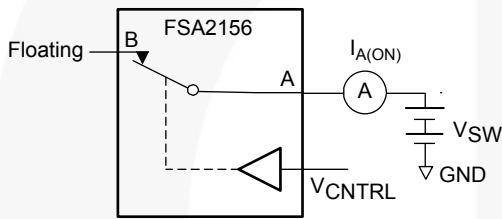
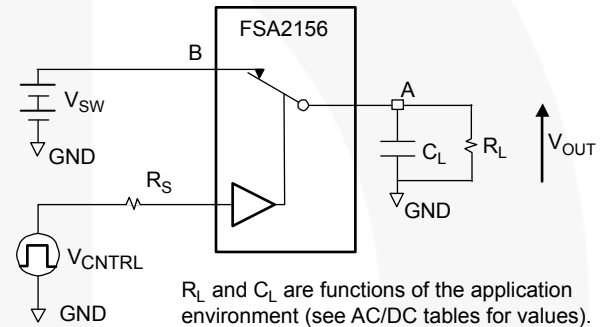

Figure 6. On Leakage



R_L and C_L are functions of the application environment (see AC/DC tables for values). C_L includes test fixture and stray capacitance.

Figure 7. Test Circuit Load

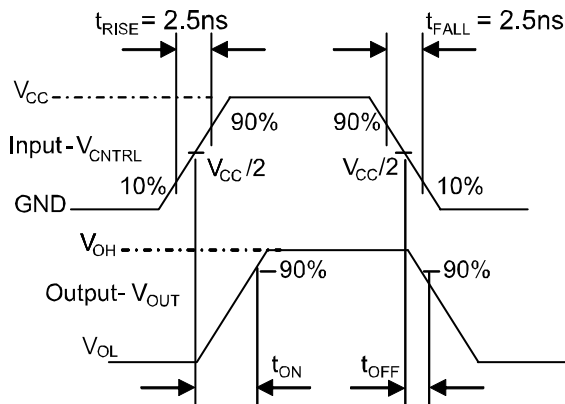
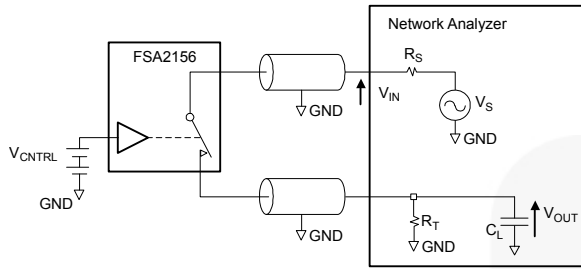

Figure 8. Turn-On / Turn-Off Waveforms

Test Diagrams (Continued)



R_T and C_L are functions of the application environment (see AC/DC tables for values). C_L includes test fixtures and stray capacitance.

Figure 9. Bandwidth

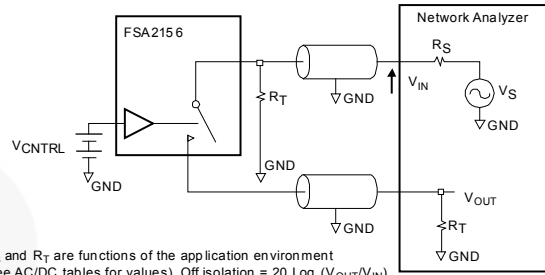

R_S and R_T are functions of the application environment (see AC/DC tables for values). Off isolation = $20 \text{ Log } (V_{OUT}/V_{IN})$.

Figure 10. Channel Off Isolation

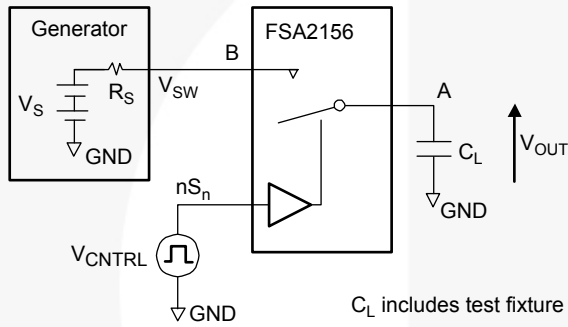

C_L includes test fixture and stray capacitance

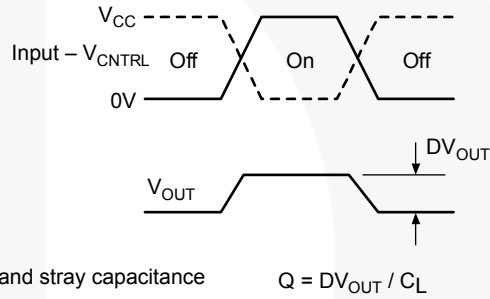

Figure 11. Charge Injection Test

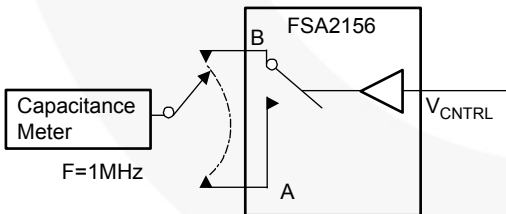

Figure 12. Channel Off Capacitance

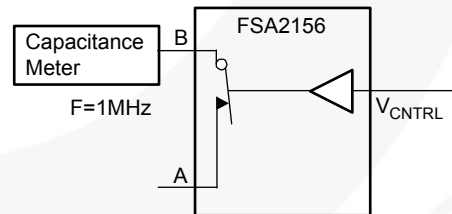

Figure 13. Channel On Capacitance

Physical Dimensions

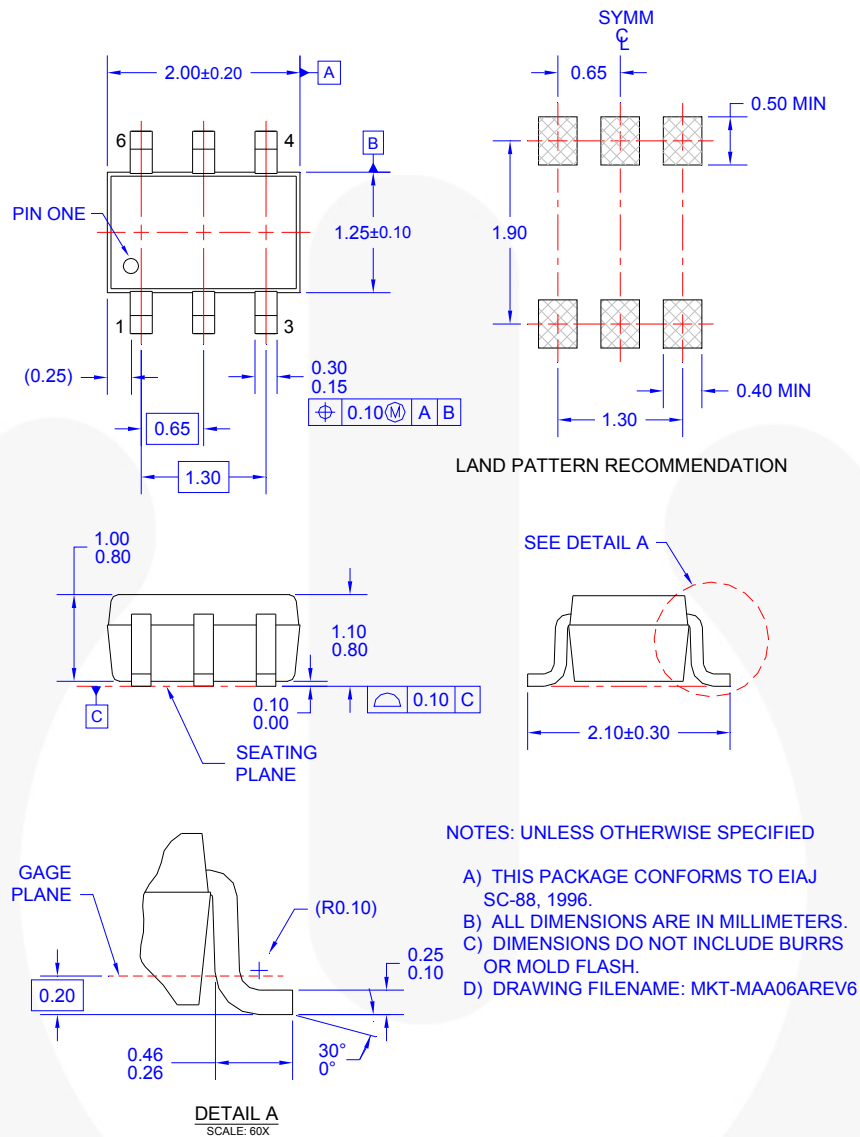

Figure 14. 6-Lead, SC70, EIAJ SC-88a, 1.25mm Wide

Package drawings are provided as a service to customers considering Fairchild components. Drawings may change in any manner without notice. Please note the revision and/or date on the drawing and contact a Fairchild Semiconductor representative to verify or obtain the most recent revision. Package specifications do not expand the terms of Fairchild's worldwide terms and conditions, specifically the warranty therein, which covers Fairchild products.

Always visit Fairchild Semiconductor's online packaging area for the most recent package drawings
<http://www.fairchildsemi.com/packaging/>.

Tape and Reel Specifications

Please visit Fairchild Semiconductor's online packaging area for the most recent tape and reel specifications:
http://www.fairchildsemi.com/products/analog/pdf/sc70-6_tr.pdf.

Package Designator	Tape Section	Cavity Number	Cavity Status	Cover Type Status
P6X	Leader (Start End)	125 (Typical)	Empty	Sealed
	Carrier	3000	Filled	Sealed
	Trailer (Hub End)	75 (Typical)	Empty	Sealed

Physical Dimensions (Continued)

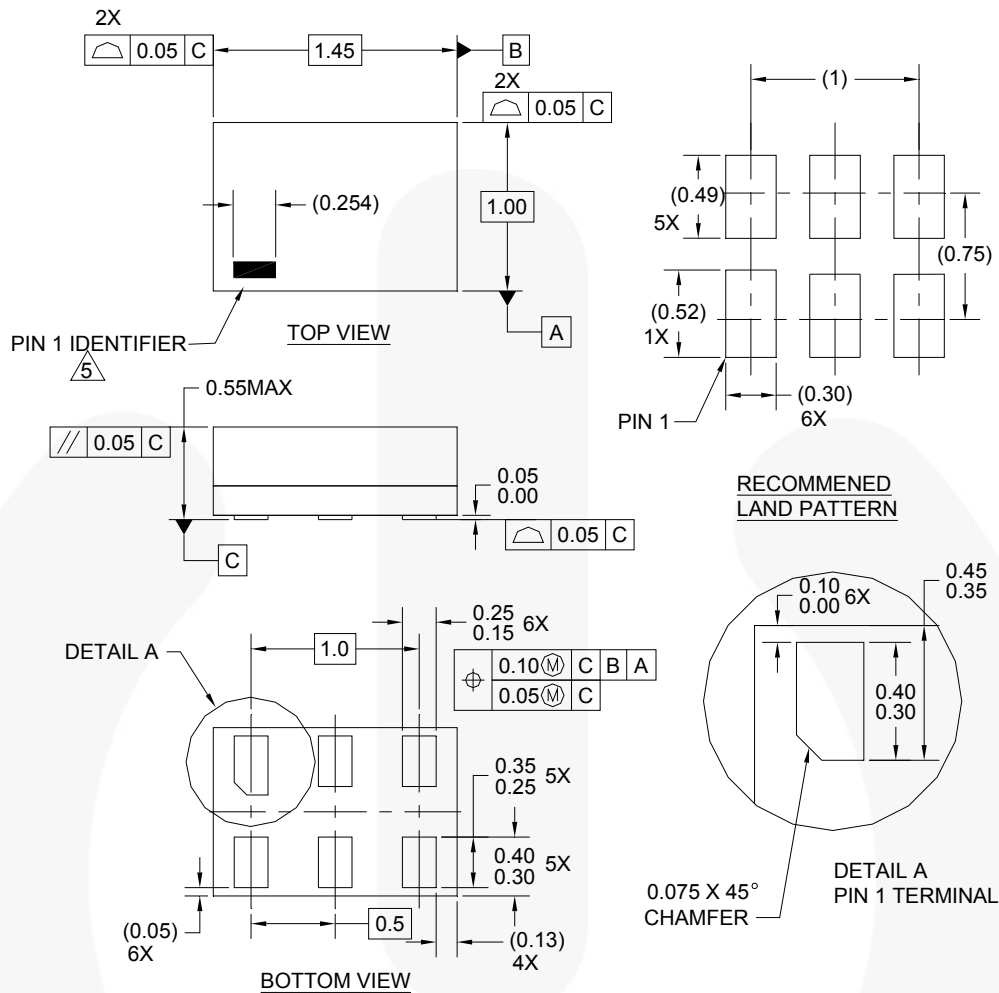

Notes:

1. CONFORMS TO JEDEC STANDARD M0-252 VARIATION UAAD
2. DIMENSIONS ARE IN MILLIMETERS
3. DRAWING CONFORMS TO ASME Y14.5M-1994
4. FILENAME AND REVISION: MAC06AREV4
5. PIN ONE IDENTIFIER IS 2X LENGTH OF ANY OTHER LINE IN THE MARK CODE LAYOUT.

Figure 15. 6-Lead, MicroPak™, 1.0mm Wide

Package drawings are provided as a service to customers considering Fairchild components. Drawings may change in any manner without notice. Please note the revision and/or date on the drawing and contact a Fairchild Semiconductor representative to verify or obtain the most recent revision. Package specifications do not expand the terms of Fairchild's worldwide terms and conditions, specifically the warranty therein, which covers Fairchild products.

Always visit Fairchild Semiconductor's online packaging area for the most recent package drawings:
<http://www.fairchildsemi.com/packaging/>.

Tape and Reel Specifications

Please visit Fairchild Semiconductor's online packaging area for the most recent tape and reel specifications:
http://www.fairchildsemi.com/products/logic/pdf/micropak_tr.pdf.

Package Designator	Tape Section	Cavity Number	Cavity Status	Cover Type Status
L6X	Leader (Start End)	125 (Typical)	Empty	Sealed
	Carrier	5000	Filled	Sealed
	Trailer (Hub End)	75 (Typical)	Empty	Sealed

Physical Dimensions (Continued)

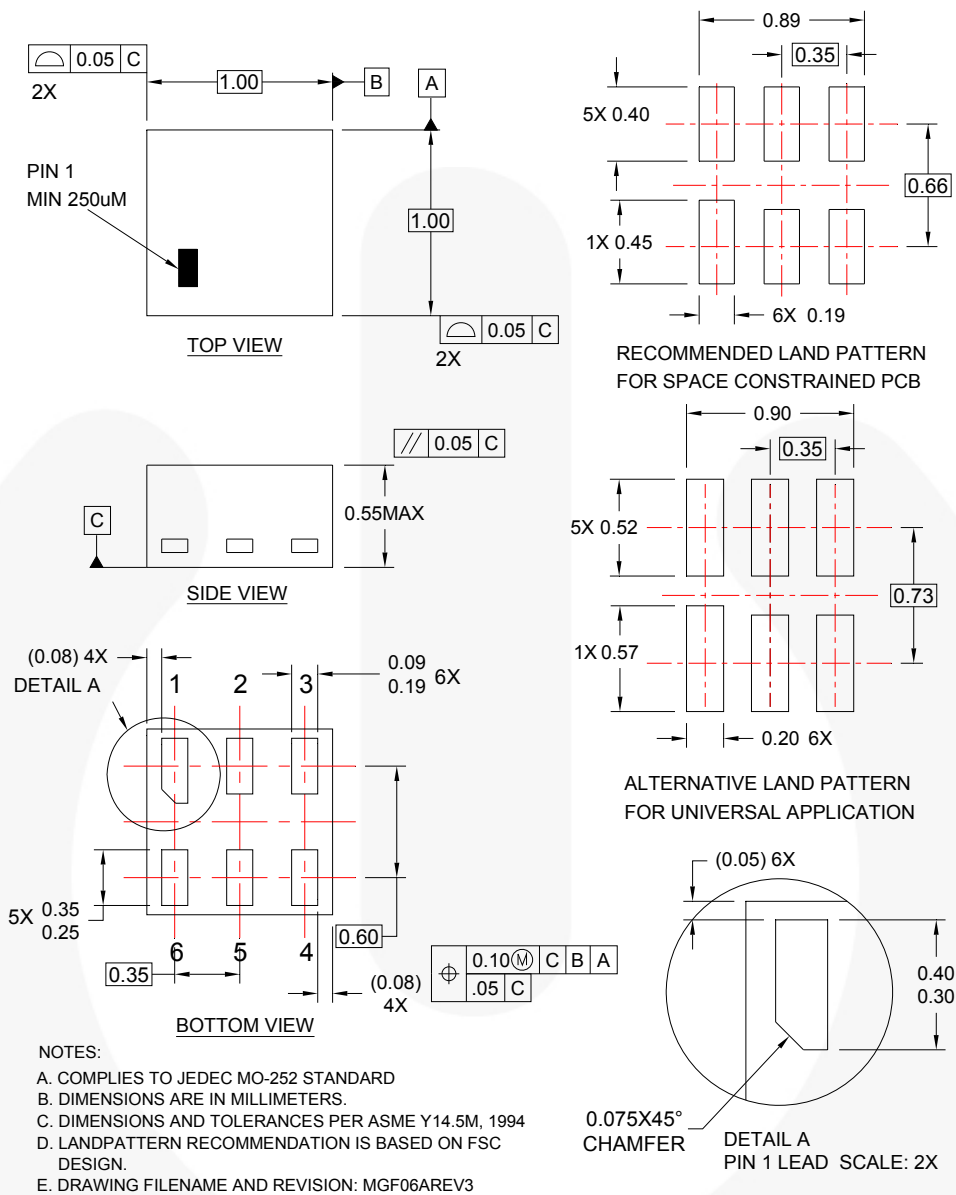

Figure 16. 6-Lead, MicroPak2, 1x1mm Body, .35mm Pitch

Package drawings are provided as a service to customers considering Fairchild components. Drawings may change in any manner without notice. Please note the revision and/or date on the drawing and contact a Fairchild Semiconductor representative to verify or obtain the most recent revision. Package specifications do not expand the terms of Fairchild's worldwide terms and conditions, specifically the warranty therein, which covers Fairchild products.

Always visit Fairchild Semiconductor's online packaging area for the most recent package drawings:
<http://www.fairchildsemi.com/packaging/>.

Tape and Reel Specifications





Please visit Fairchild Semiconductor's online packaging area for the most recent tape and reel specifications:
http://www.fairchildsemi.com/packaging/MicroPAK2_6L_tr.pdf.

Package Designator	Tape Section	Cavity Number	Cavity Status	Cover Type Status
FHX	Leader (Start End)	125 (Typical)	Empty	Sealed
	Carrier	5000	Filled	Sealed
	Trailer (Hub End)	75 (Typical)	Empty	Sealed



TRADEMARKS

The following includes registered and unregistered trademarks and service marks, owned by Fairchild Semiconductor and/or its global subsidiaries, and is not intended to be an exhaustive list of all such trademarks.

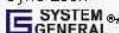
- | | | | |
|---|---|---|---|
| AccuPower™ | F-PFS™ | Power-SPM™ | The Power Franchise® |
| Auto-SPM™ | FRFET® | PowerTrench® | The Right Technology for Your Success™ |
| AX-CAP™* | Global Power Resource™ | PowerXS™ | the power franchise |
| Build it Now™ | Green FPS™ | Programmable Active Droop™ | TinyBoost™ |
| CorePLUS™ | Green FPS™ e-Series™ | QFET® | TinyBuck™ |
| CorePOWER™ | Gmax™ | QS™ | TinyCalc™ |
| CROSSVOL™ | GTO™ | Quiet Series™ | TinyLogic® |
| CTL™ | IntelliMAX™ | RapidConfigure™ | TINYOPTO™ |
| Current Transfer Logic™ | ISOPLANAR™ |  ™ | TinyPower™ |
| DEUXPEED® | MegaBuck™ | Saving our world, 1mW/kW at a time™ | TinyPower™ |
| Dual Cool™ | MICROCOUPLER™ | SignalWise™ | TinyPVM™ |
| EcoSPARK® | MicroFET™ | SmartMax™ | TinyWire™ |
| EfficientMax™ | MicroPak™ | SMART START™ | TriFault Detect™ |
| ESBC™ | MicroPak2™ | SPM® | TRUECURRENT®* |
|  ™ | MillerDrive™ | STEALTH™ | µSerDes™ |
| Fairchild® | MotionMax™ | SuperFET® |  ™ |
| Fairchild Semiconductor® | Motion-SPM™ | SuperSOT™-3 | UHC® |
| FACT Quiet Series™ | mW Saver™ | SuperSOT™-6 | Ultra FRFET™ |
| FACT® | OptoHIT™ | SuperSOT™-8 | UniFET™ |
| FAST® | OPTOLOGIC® | SupreMOS® | VCM™ |
| FastvCore™ | OPTOPLANAR® | SynCFET™ | VisualMax™ |
| FETBench™ |  ™ | SynC-Lock™ | XST™ |
| FlashWriter®* | PDP SPM™ |  ™ | |
| FPS™ | | | |

* Trademarks of System General Corporation, used under license by Fairchild Semiconductor.

DISCLAIMER

FAIRCHILD SEMICONDUCTOR RESERVES THE RIGHT TO MAKE CHANGES WITHOUT FURTHER NOTICE TO ANY PRODUCTS HEREIN TO IMPROVE RELIABILITY, FUNCTION, OR DESIGN. FAIRCHILD DOES NOT ASSUME ANY LIABILITY ARISING OUT OF THE APPLICATION OR USE OF ANY PRODUCT OR CIRCUIT DESCRIBED HEREIN; NEITHER DOES IT CONVEY ANY LICENSE UNDER ITS PATENT RIGHTS, NOR THE RIGHTS OF OTHERS. THESE SPECIFICATIONS DO NOT EXPAND THE TERMS OF FAIRCHILD'S WORLDWIDE TERMS AND CONDITIONS, SPECIFICALLY THE WARRANTY THEREIN, WHICH COVERS THESE PRODUCTS.

LIFE SUPPORT POLICY

FAIRCHILD'S PRODUCTS ARE NOT AUTHORIZED FOR USE AS CRITICAL COMPONENTS IN LIFE SUPPORT DEVICES OR SYSTEMS WITHOUT THE EXPRESS WRITTEN APPROVAL OF FAIRCHILD SEMICONDUCTOR CORPORATION.

As used herein:

1. Life support devices or systems are devices or systems which, (a) are intended for surgical implant into the body or (b) support or sustain life, and (c) whose failure to perform when properly used in accordance with instructions for use provided in the labeling, can be reasonably expected to result in a significant injury of the user.
2. A critical component in any component of a life support, device, or system whose failure to perform can be reasonably expected to cause the failure of the life support device or system, or to affect its safety or effectiveness.

ANTI-COUNTERFEITING POLICY

Fairchild Semiconductor Corporation's Anti-Counterfeiting Policy, Fairchild's Anti-Counterfeiting Policy is also stated on our external website, www.fairchildsemi.com, under Sales Support.

Counterfeiting of semiconductor parts is a growing problem in the industry. All manufacturers of semiconductor products are experiencing counterfeiting of their parts. Customers who inadvertently purchase counterfeit parts experience many problems such as loss of brand reputation, substandard performance, failed applications, and increased cost of production and manufacturing delays. Fairchild is taking strong measures to protect ourselves and our customers from the proliferation of counterfeit parts. Fairchild strongly encourages customers to purchase Fairchild parts either directly from Fairchild or from Authorized Fairchild Distributors who are listed by country on our web page cited above. Products customers buy either from Fairchild directly or from Authorized Fairchild Distributors are genuine parts, have full traceability, meet Fairchild's quality standards for handling and storage and provide access to Fairchild's full range of up-to-date technical and product information. Fairchild and our Authorized Distributors will stand behind all warranties and will appropriately address any warranty issues that may arise. Fairchild will not provide any warranty coverage or other assistance for parts bought from Unauthorized Sources. Fairchild is committed to combat this global problem and encourage our customers to do their part in stopping this practice by buying direct or from authorized distributors.

PRODUCT STATUS DEFINITIONS

Definition of Terms

Datasheet Identification	Product Status	Definition
Advance Information	Formative / In Design	Datasheet contains the design specifications for product development. Specifications may change in any manner without notice.
Preliminary	First Production	Datasheet contains preliminary data; supplementary data will be published at a later date. Fairchild Semiconductor reserves the right to make changes at any time without notice to improve design.
No Identification Needed	Full Production	Datasheet contains final specifications. Fairchild Semiconductor reserves the right to make changes at any time without notice to improve the design.
Obsolete	Not In Production	Datasheet contains specifications on a product that is discontinued by Fairchild Semiconductor. The datasheet is for reference information only.

Rev. I53