

FR014H5JZ (14mΩ, -30V) High-Side Reverse Bias / Reverse Polarity Protector With Integrated Over Voltage Transient Suppression

Features

- Up to -30V Reverse-Bias Protection
- Nano Seconds of Reverse-Bias Blocking Response Time
- +32V 24-Hour “Withstand” Rating
- 14mΩ Typical Series Resistance at 5V
- Integrated TVS Over Voltage Suppression
- MLP 3.3x3.3 Package Size
- RoHs Compliant
- USB Tested and Compatible

Applications

- USB 1.0, 2.0 and 3.0 Devices
- USB Charging
- Mobile Devices
- Mobile Medical
- POS Systems
- Toys
- Any DC Barrel Jack Powered Device
- Any DC Devices subject to Negative Hot Plug or Inductive Transients
- Automotive Peripherals

Description

Reverse bias is an increasingly common fault event that may be generated by user error, improperly installed batteries, automotive environments, erroneous connections to third-party chargers, negative “hot plug” transients, inductive transients, and readily available negatively biased rouge USB chargers.

Fairchild circuit protection is proud to offer a new type of reverse bias protection devices. The FR devices are low resistance, series switches that, in the event of a reverse bias condition, shut off power and block the negative voltage to help protect downstream circuits.

The FR devices are optimized for the application to offer best in class reverse bias protection and voltage capabilities while minimizing size, series voltage drop, and normal operating power consumption.

In the event of a reverse bias application, FR014H5JZ devices effectively provide a full voltage block and can easily protect -0.3V rated silicon.

From a power perspective, in normal bias, a 14mΩ FR device in a 1.5A application will generate only 21mV of voltage drop or 32mW of power loss. In reverse bias, FR devices dissipate less than 20μW in a 16V reverse bias event. This type of performance is not possible with a diode solution.

Benefits extend beyond the device. Due to low power dissipation, not only is the device small, but heat sinking requirements and cost can be minimized as well.

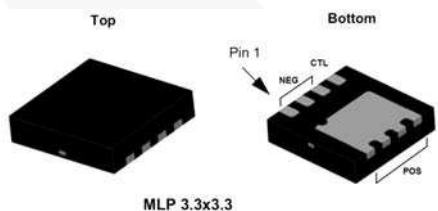

Ordering Information

Part Number	Top Mark	Package	Packing Method
FR014H5JZ	14H	8-Lead, Molded Leadless Package (MLP), Dual, 3.3mm Square	3000 on Tape & Reel; 13-inch Reel, 12mm Tape

Diagrams

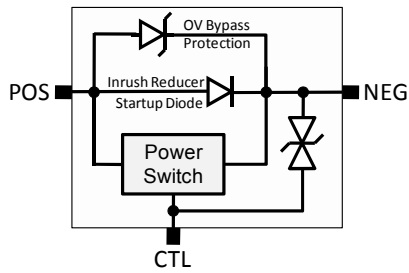

Figure 1. Block Diagram

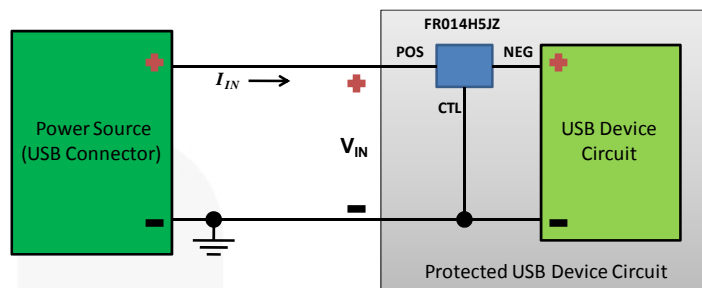

Figure 2. Typical Schematic

Pin Configuration

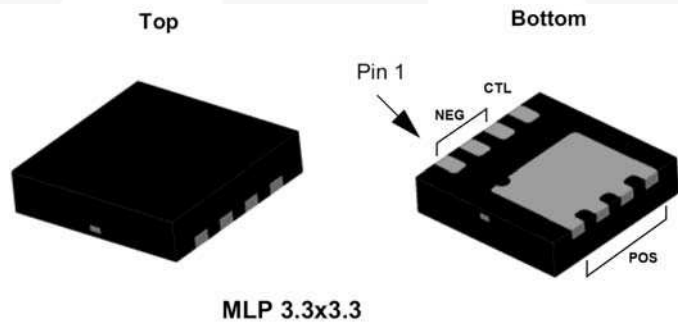

Figure 3. Pin Assignments

Pin Definitions

Name	Pin	Description
POS	5, 6, 7, 8	The positive terminal of the power source. Current flows into this pin during normal operation.
CTL	4	The control pin of the device. A negative voltage to the POS pin turns the switch on and a positive voltage turns the switch to a high-impedance state.
NEG	1, 2, 3	The positive terminal of the load circuit to be protected. Current flows out of this pin during normal operation.

Absolute Maximum Ratings

Values are at $T_A=25^\circ\text{C}$ unless otherwise noted.

Symbol	Parameter		Values	Unit		
$V_{+ \text{ MAX_OP}}$	Steady-State Normal Operating Voltage between POS and CTL Pins ($V_{\text{IN}} = V_{+ \text{ MAX_OP}}$, $I_{\text{IN}} = 1.5\text{A}$, Switch On)		+25	V		
$V_{+ 24}$	24-Hour Normal Operating Voltage Withstand Capability between POS and CTL Pins ($V_{\text{IN}} = V_{+ 24}$, $I_{\text{IN}} = 1.5\text{A}$, Switch On) ⁽¹⁾		+32			
$V_{- \text{ MAX_OP}}$	Steady-State Reverse Bias Standoff Voltage between POS and CTL Pins ($V_{\text{IN}} = V_{- \text{ MAX_OP}}$)		-30			
I_{IN}	Input Current	Continuous ⁽²⁾ (see Figure 4)	9	A		
T_J	Operating Junction Temperature		150	$^\circ\text{C}$		
P_D	Power Dissipation	$T_C = 25^\circ\text{C}$	36	W		
		$T_A = 25^\circ\text{C}$ ⁽²⁾ (see Figure 4)	2.3			
$I_{\text{DIODE_CONT}}$	Steady-State Diode Continuous Forward Current from POS to NEG ⁽²⁾ (see Figure 4)		2	A		
$I_{\text{DIODE_PULSE}}$	Pulsed Diode Forward Current from POS to NEG (300 μs Pulse) ⁽²⁾ (see Figure 5)		450			
ESD	Electrostatic Discharge Capability	Human Body Model, JESD22-A114		8	kV	
		Charged Device Model, JESD22-C101		2		
		System Model, IEC61000-4-2	NEG is shorted to CTL and connected to GND	Contact		8
				Air		15
			No external connection between NEG and CTL	Contact		3
				Air		4

Notes:

- The V_{+24} rating is NOT a survival guarantee. It is a statistically calculated survivability reference point taken on qualification devices, where the predicted failure rate is less than 0.01% at the specified voltage for 24 hours. It is intended to indicate the device's ability to withstand transient events that exceed the recommended operating voltage rating. Specification is based on qualification devices tested using accelerated destructive testing at higher voltages, as well as production pulse testing at the V_{+24} level. Production device field life results may vary. Results are also subject to variation based on implementation, environmental considerations, and circuit dynamics. Systems should never be designed with the intent to normally operate at V_{+24} levels. Contact Fairchild Semiconductor for additional information.
- The device power dissipation and thermal resistance (R_θ) are characterized with device mounted on the following FR4 printed circuit boards, as shown in Figure 4 and Figure 5

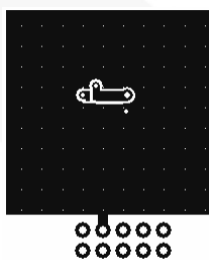

Figure 4. 1 Square Inch of 2-ounce copper

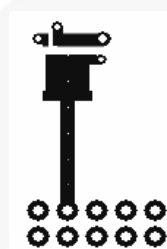

Figure 5. Minimum Pads of 2-ounce Copper

Thermal Characteristics

Symbol	Parameter	Value	Unit
$R_{\theta\text{JC}}$	Thermal Resistance, Junction to Case	3.4	$^\circ\text{C}/\text{W}$
$R_{\theta\text{JA}}$	Thermal Resistance, Junction to Ambient ⁽²⁾ (see Figure 4)	50	

Electrical Characteristics

Values are at $T_A = 25^\circ\text{C}$ unless otherwise noted.

Symbol	Parameter	Conditions	Min.	Typ.	Max.	Unit
Positive Bias Characteristics						
R_{ON}	Device Resistance, Switch On	$V_{IN} = +4\text{V}, I_{IN} = 1.5\text{A}$		18	23	m Ω
		$V_{IN} = +5\text{V}, I_{IN} = 1.5\text{A}$		14	19	
		$V_{IN} = +5\text{V}, I_{IN} = 1.5\text{A}, T_J = 125^\circ\text{C}$		20		
		$V_{IN} = +12\text{V}, I_{IN} = 1.5\text{A}$		11	14	
V_{ON}	Input Voltage, V_{IN} , at which Voltage at POS, V_{POS} , Reaches a Certain Level at Given Current	$I_{IN} = 100\text{mA}, V_{POS} - V_{NEG} = 50\text{mV}, V_{CTL} = 0\text{V}$	2.0	2.4	3.0	V
$\Delta V_{ON} / \Delta T_J$	Temperature Coefficient of V_{ON}			-3.52		mV/ $^\circ\text{C}$
V_F	Diode Forward Voltage	$V_{CTL} = V_{NEG}, I_{DIODE} = 0.1\text{A}, \text{Pulse width} < 300\mu\text{s}$	0.57	0.63	0.70	V
I_{BIAS}	Bias Current Flowing into POS Pin during Normal Bias Operation	$V_{POS} = 5\text{V}, V_{CTL} = 0\text{V}, \text{No Load}$		30		nA
Negative Bias Characteristics						
V_{-MAX_OP}	Reverse Bias Breakdown Voltage				-30	V
$\Delta V_{-MAX_OP} / \Delta T_J$	Reverse Bias Breakdown Voltage Temperature Coefficient	$I_{IN} = -250\mu\text{A}, V_{CTL} = V_{NEG} = 0\text{V}$		22.5		mV/ $^\circ\text{C}$
I_{-}	Leakage Current from NEG to POS in Reverse-Bias Condition	$V_{POS} = -20\text{V}, V_{CTL} = V_{NEG} = 0\text{V}$		1		μA
t_{RN}	Time to Respond to Negative Bias Condition	$V_{CTL} = 5\text{V}, V_{POS} = 0\text{V}, C_{LOAD} = 10\mu\text{F}, \text{Reverse Bias Startup Inrush Current} = 0.2\text{A}$			50	ns
Integrated TVS Performance						
V_Z	Breakdown Voltage @ I_T	$I_T = 1\text{mA}, 300\mu\text{s Pulse}$	28.5	30	31.2	V
I_R	Leakage Current from NEG to CTL	$V_{NEG} = +25\text{V}, V_{CTL} = 0\text{V}$		1.5	10	μA
		$V_{NEG} = -25\text{V}, V_{CTL} = 0\text{V}$		-1.5	-10	
I_{PPM}	Max Pulse Current from NEG to CTL	IEC61000-4-5 8x20 μs pulse	$V_{NEG} > V_{CTL}$		0.8	A
			$V_{NEG} < V_{CTL}$		-0.9	
V_C	Clamping Voltage form NEG to CTL at I_{PPM}	IEC61000-4-5 8x20 μs pulse	$V_{NEG} > V_{CTL}$	34		V
			$V_{NEG} < V_{CTL}$		-34	
Dynamic Characteristics						
C_i	Input Capacitance between POS and CTL			2440		pF
C_S	Switch Capacitance between POS and NEG	$V_{IN} = -5\text{V}, V_{CTL} = V_{NEG} = 0\text{V}, f = 1\text{MHz}$		564		
C_O	Output Capacitance between NEG and CTL			2526		
R_C	Control Internal Resistance			3.6		

Typical Characteristics

$T_J = 25^\circ\text{C}$ unless otherwise specified.

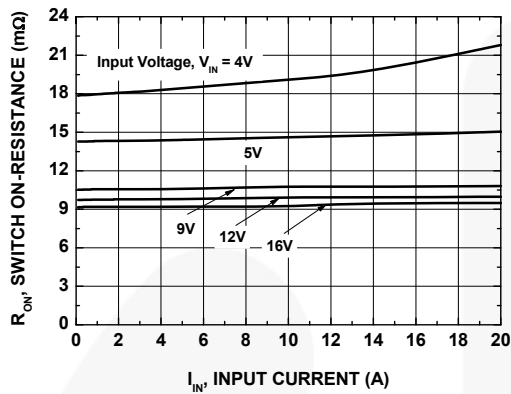

Figure 6. Switch On Resistance vs. Switch Current

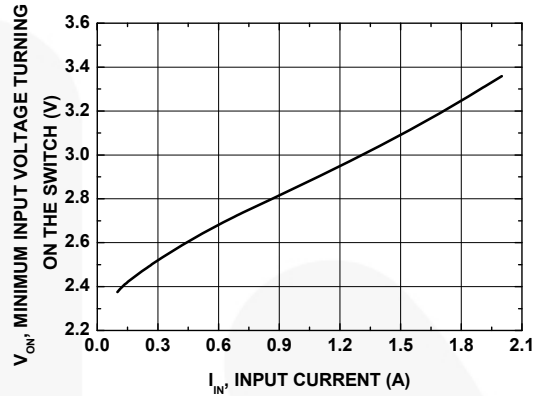

Figure 7. Minimum Input Voltage to Turn On Switch vs. Current at 50mV Switch Voltage Drop

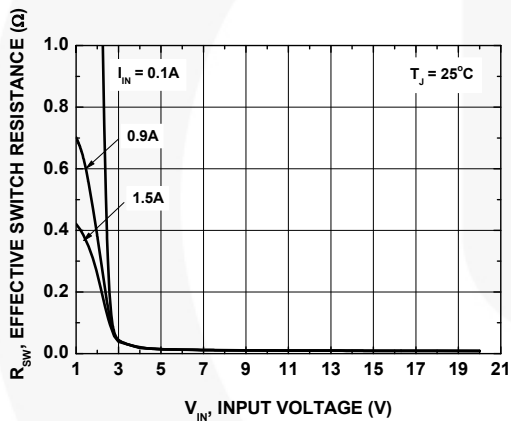

Figure 8. Effective Switch Resistance R_{SW} vs. Input Voltage V_{IN}

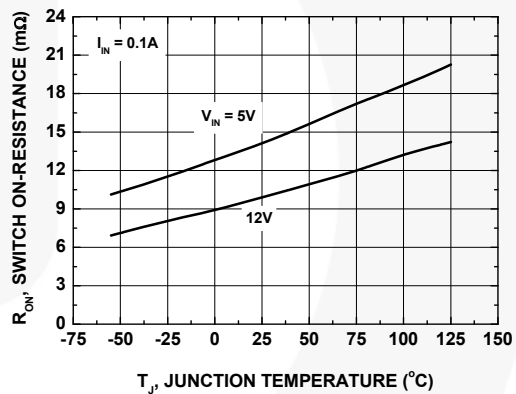

Figure 9. Switch On Resistance vs. Junction Temperature at 0.1A

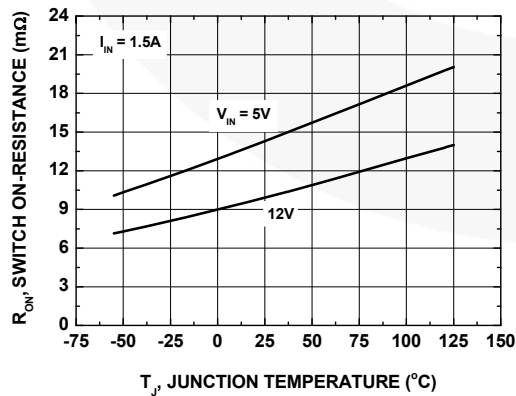

Figure 10. Switch On Resistance vs. Junction Temperature at 1.5A

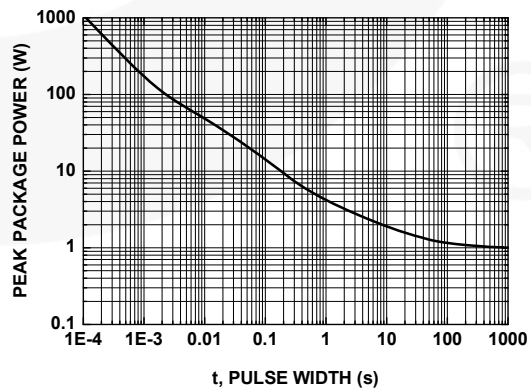

Figure 11. Single-Pulse Maximum Power vs. Time

Typical Characteristics

$T_J = 25^\circ\text{C}$ unless otherwise specified.

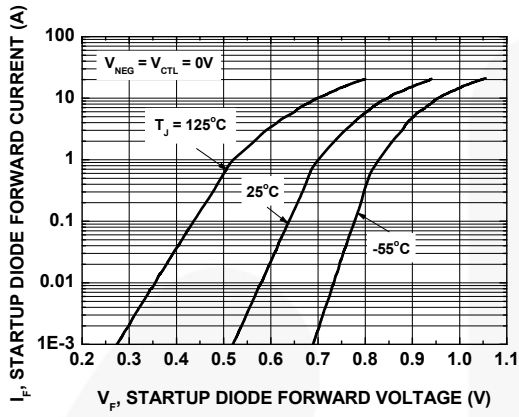

Figure 12. Startup Diode Current vs. Forward Voltage

Application Test Configurations

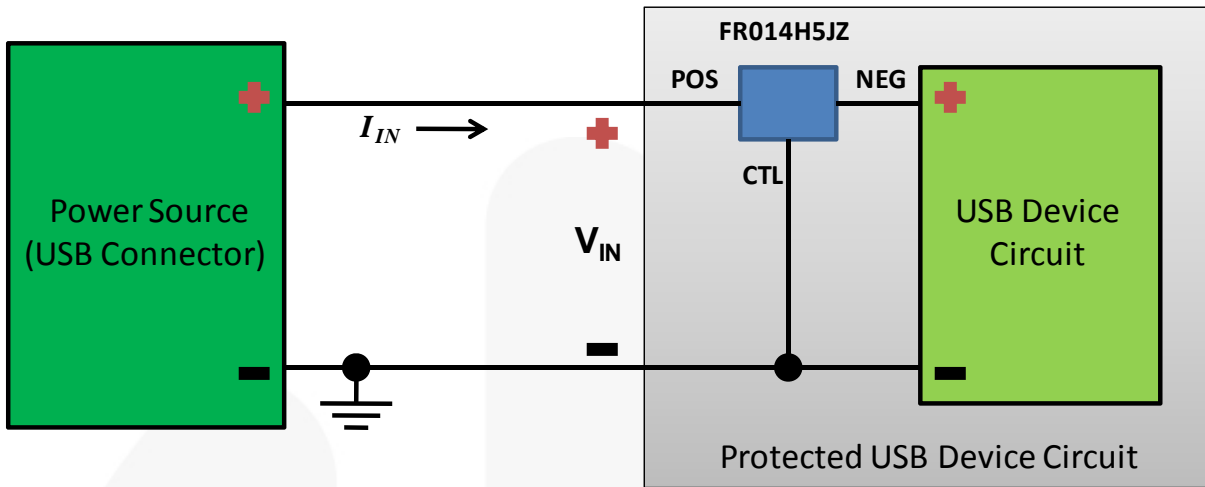

Figure 13. Typical Application Circuit for USB Applications

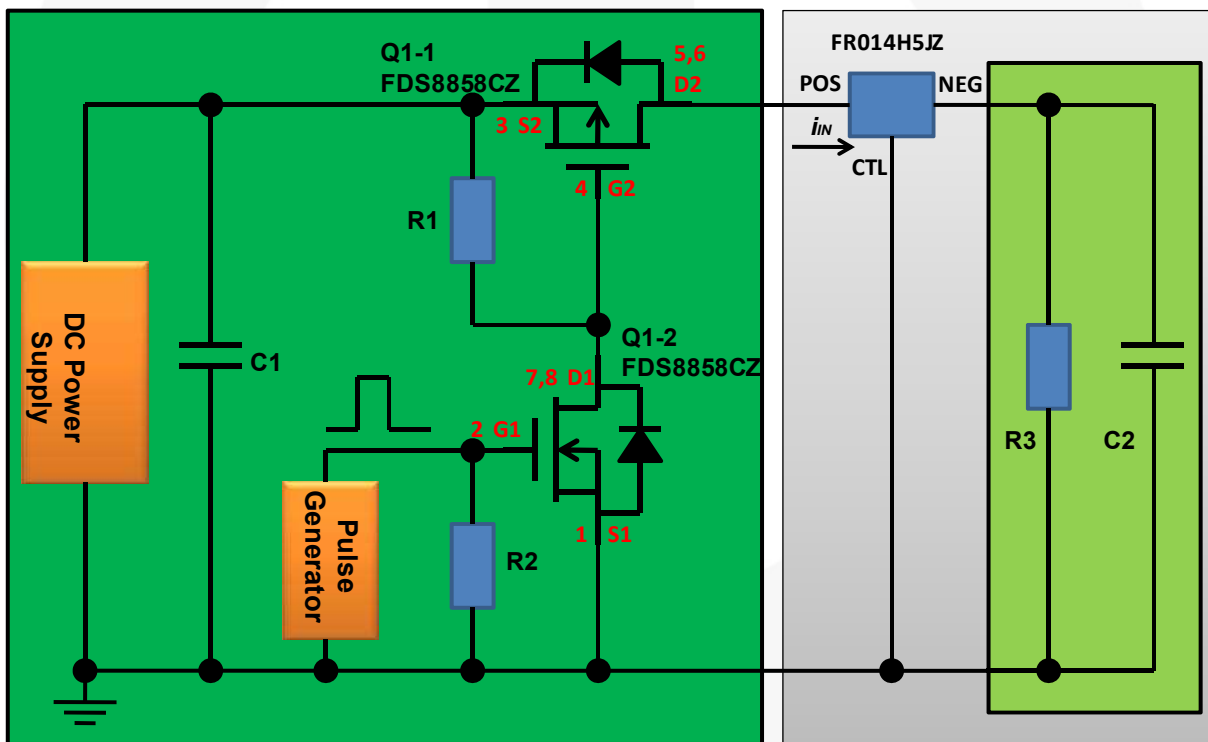

Figure 14. Startup Test Circuit – Normal Bias with FR014H5JZ

Application Test Configurations (Continued)

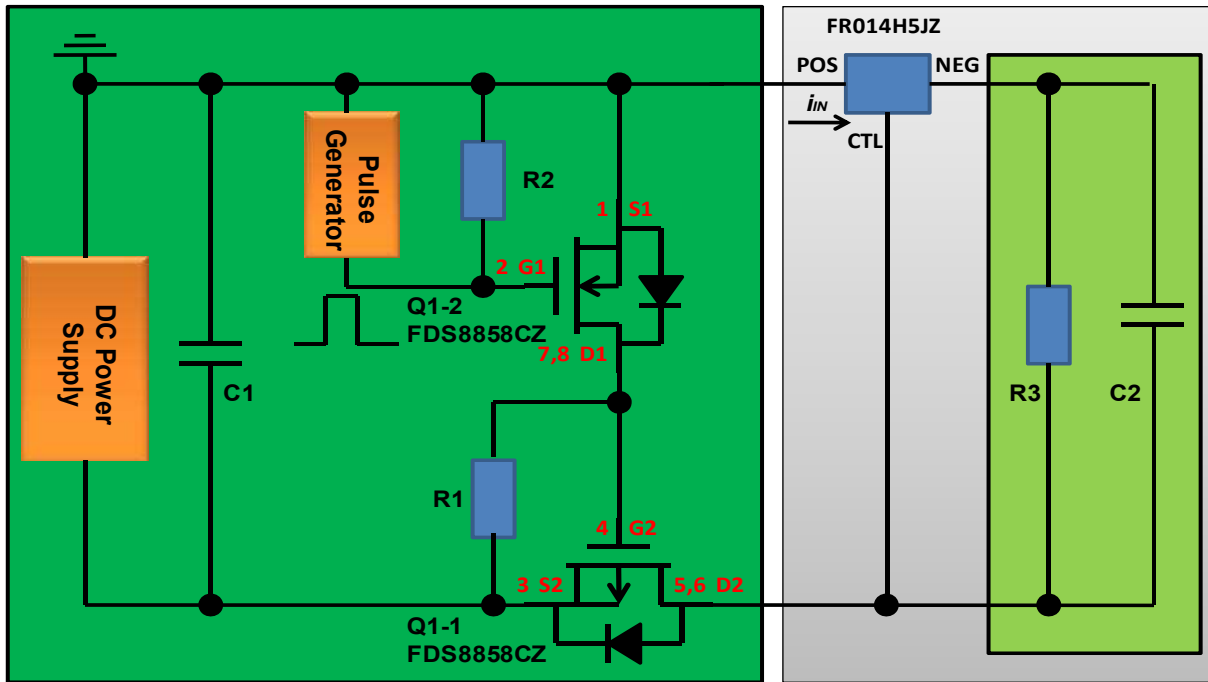

Figure 15. Startup Test Circuit – Reverse Bias with FR014H5JZ

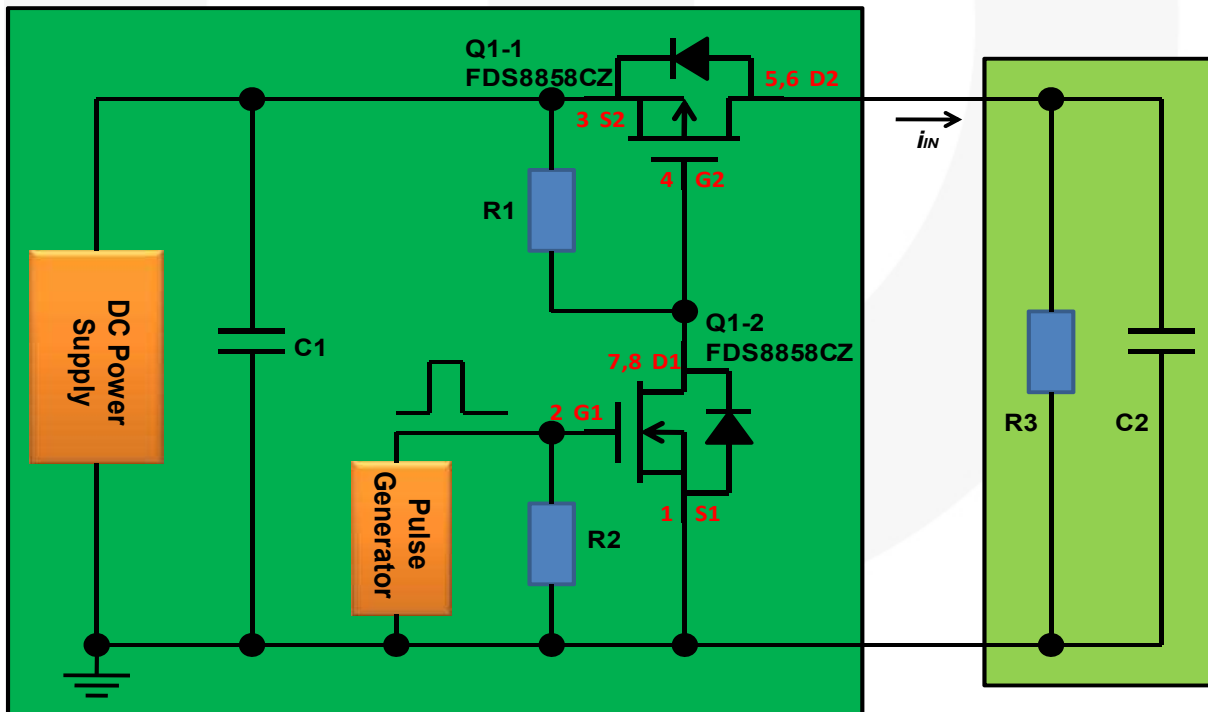

Figure 16. Startup Test Circuit – without FR014H5JZ

Typical Application Waveforms

Typical USB3.0 conditions.

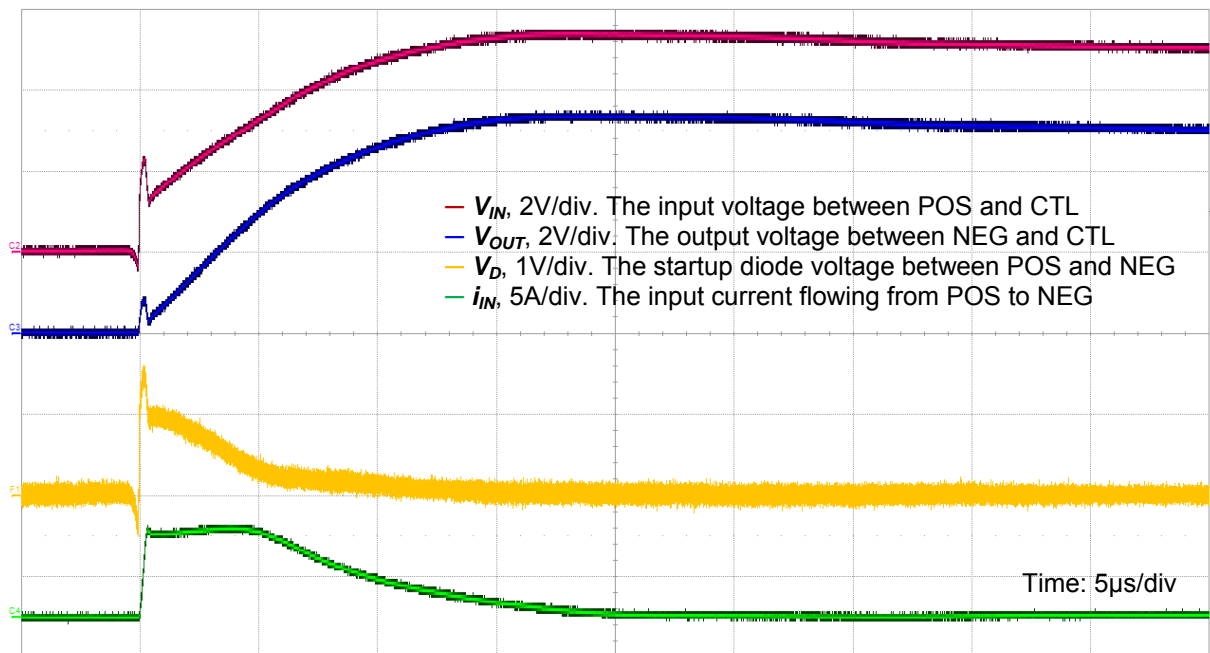

Figure 17. Normal Bias Startup Waveform, DC Power Source=5V, $C_1=100\mu\text{F}$, $C_2=10\mu\text{F}$, $R_1=R_2=10\text{k}\Omega$, $R_3=27\Omega$

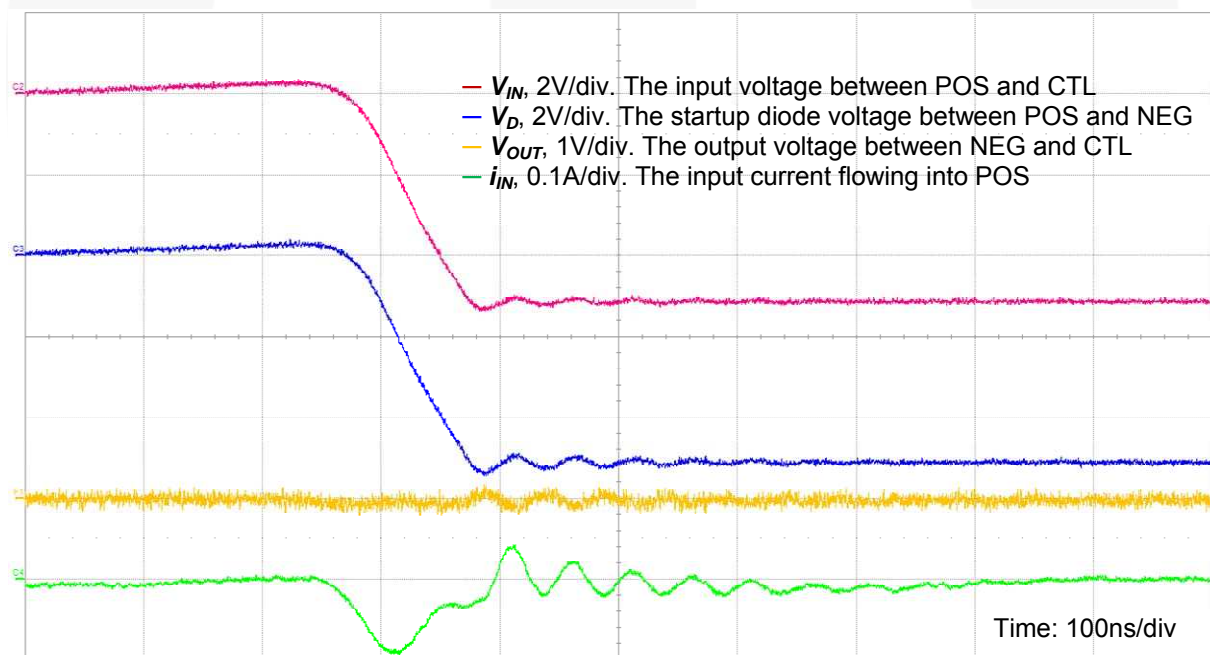

Figure 18. Reverse Bias Startup Waveform, DC Power Source=5V, $C_1=100\mu\text{F}$, $C_2=10\mu\text{F}$, $R_1=R_2=10\text{k}\Omega$, $R_3=27\Omega$

Typical Application Waveforms (Continued)

Typical USB3.0 conditions.

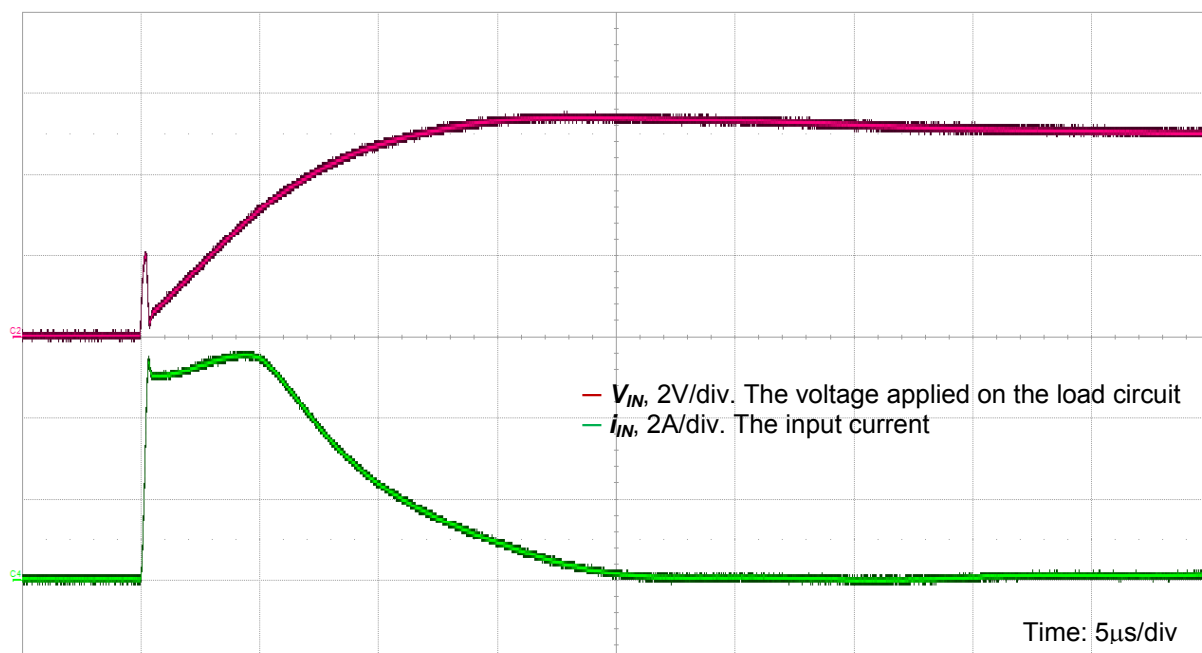

Figure 19. Startup Waveform without FR014H5JZ, DC Power Source=5V, $C_1=100\mu\text{F}$, $C_2=10\mu\text{F}$, $R_1=R_2=10\text{k}\Omega$, $R_3=27\Omega$

Application Information

Figure 17 shows the voltage and current waveforms when a virtual USB3.0 device is connected to a 5V source. A USB application allows a maximum source output capacitance of $C_1 = 120\mu\text{F}$ and a maximum device-side input capacitance of $C_2 = 10\mu\text{F}$ plus a maximum load (minimum resistance) of $R_3 = 27\Omega$. $C_1 = 100\mu\text{F}$, $C_2 = 10\mu\text{F}$ and $R_3 = 27\Omega$ were used for testing.

When the DC power source is connected to the circuit (refer to Figure 13), the built-in startup diode initially conducts the current such that the USB device powers up. Due to the initial diode voltage drop, the FR014H5JZ effectively reduces the peak inrush current of a hot plug event. Under these test conditions, the input inrush current reaches about 6A peak. While the current flows, the input voltage increases. The speed of this input voltage increase depends on the time constant formed by the load resistance R_3 and load capacitance C_2 . The larger the time constant, the slower the input voltage increase. As the input voltage approaches a level equal to the protector's turn-on voltage, V_{ON} , the protector turns on and operates in Low-Resistance Mode as defined by V_{IN} and operating current I_{IN} .

In the event of a negative transient, or when the DC power source is reversely connected to the circuit, the device blocks the flow of current and holds off the voltage, thereby protecting the USB device. Figure 18 shows the voltage and current waveforms when a virtual

USB3.0 device is reversely biased; the output voltage is near 0 and response time is less than 50ns.

Figure 19 shows the voltage and current waveforms when no reverse bias protection is implemented. In Figure 17, while the reverse bias protector is present, the input voltage, V_{IN} , and the output voltage, V_O , are separated and look different. When this reverse bias protector is removed, V_{IN} and V_O merge, as shown in Figure 19 as V_{IN} . This V_{IN} is also the voltage applied to the load circuit. It can be seen that, with reverse bias protection, the voltage applied to the load and the current flowing into the load look very much the same as without reverse bias protection.

Benefits of Reverse Bias Protection

The most important benefit is to prevent accidentally reverse-biased voltage from damaging the USB load. Another benefit is that the peak startup inrush current can be reduced. How fast the input voltage rises, the input/output capacitance, the input voltage, and how heavy the load is determine how much the inrush current can be reduced. In a 5V USB application, for example, the inrush current can be 5% - 20% less with different input voltage rising rate and other factors. This can offer a system designer the option of increasing C_2 while keeping "effective" USB device capacitance down.

Physical Dimensions

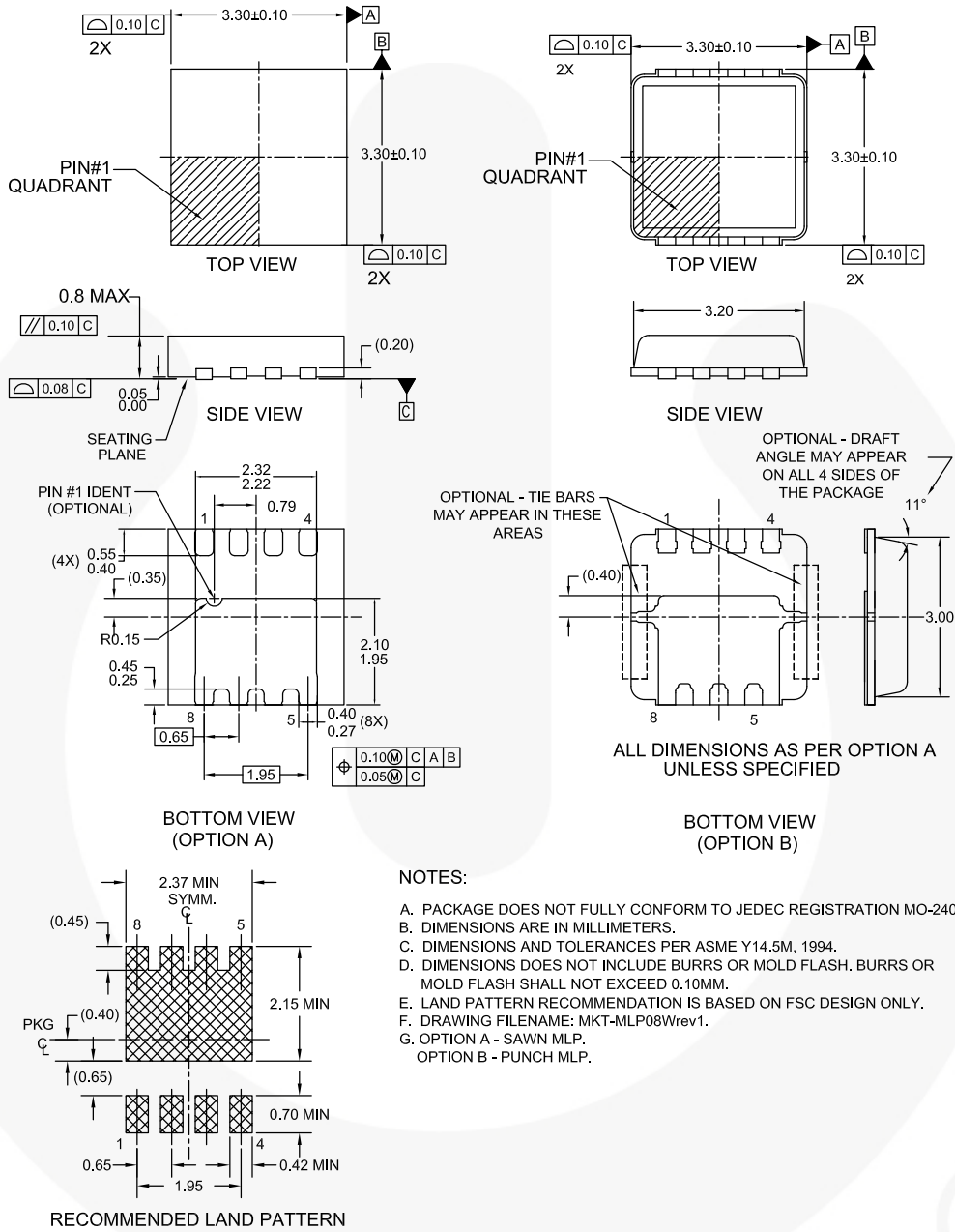

Figure 20. 8-Lead, Molded Leadless Package (MLP), 3.3mm Square





Package drawings are provided as a service to customers considering Fairchild components. Drawings may change in any manner without notice. Please note the revision and/or date on the drawing and contact a Fairchild Semiconductor representative to verify or obtain the most recent revision. Package specifications do not expand the terms of Fairchild's worldwide terms and conditions, specifically the warranty therein, which covers Fairchild products.

Always visit Fairchild Semiconductor's online packaging area for the most recent package drawings:
<http://www.fairchildsemi.com/packaging/>



TRADEMARKS

The following includes registered and unregistered trademarks and service marks, owned by Fairchild Semiconductor and/or its global subsidiaries, and is not intended to be an exhaustive list of all such trademarks.

- | | | | |
|----------------------------------------------------------------------------------------------|------------------------------------------------|----------------------------------------------------------------------------------------------------|---------------------------------------------------------------------------------------------|
| 2Cool™ | F-PFS™ | PowerTrench® | The Power Franchise® |
| AccuPower™ | FRFET® | PowerXS™ | the power franchise |
| AX-CAP™* | Global Power Resource™ | Programmable Active Droop™ | TinyBoost™ |
| BitSiC™ | GreenBridge™ | QFET® | TinyBuck™ |
| Build it Now™ | Green FPS™ | QS™ | TinyCalc™ |
| CorePLUS™ | Green FPS™ e-Series™ | Quiet Series™ | TinyLogic® |
| CorePOWER™ | Gmax™ | RapidConfigure™ | TINYOPTO™ |
| CROSSVOLT™ | GTO™ |  ™ | TinyPower™ |
| CTL™ | IntelliMAX™ | Saving our world, 1mW/W/kW at a time™ | TinyPWM™ |
| Current Transfer Logic™ | ISOPANAR™ | SignalWise™ | TinyWire™ |
| DEUXPEED® | Making Small Speakers Sound Louder and Better™ | SmartMax™ | TranSiC™ |
| Dual Cool™ | MegaBuck™ | SMART START™ | TriFault Detect™ |
| EcoSPARK® | MICROCOUPLER™ | Solutions for Your Success™ | TRUECURRENT®* |
| EfficientMax™ | MicroFET™ | SPM® | µSerDes™ |
| ESBC™ | MicroPak™ | STEALTH™ |  SerDes™ |
|  Fairchild® | MicroPak2™ | SuperFET® | UHC® |
| Fairchild Semiconductor® | MillerDrive™ | SuperSOT™-3 | Ultra FRFET™ |
| FACT Quiet Series™ | MotionMax™ | SuperSOT™-6 | UniFET™ |
| FACT® | Motion-SPM™ | SuperSOT™-8 | VCX™ |
| FAST® | mWSaver™ | SupreMOS® | VisualMax™ |
| FastvCore™ | OptoHiT™ | SyncFET™ | VoltagePlus™ |
| FETBench™ | OPTOLOGIC® | Sync-Lock™ | XS™ |
| FlashWriter®* | OPTOPLANAR® |  SYSTEM GENERAL®* | |
| FPS™ | | | |

* Trademarks of System General Corporation, used under license by Fairchild Semiconductor.

DISCLAIMER

FAIRCHILD SEMICONDUCTOR RESERVES THE RIGHT TO MAKE CHANGES WITHOUT FURTHER NOTICE TO ANY PRODUCTS HEREIN TO IMPROVE RELIABILITY, FUNCTION, OR DESIGN. FAIRCHILD DOES NOT ASSUME ANY LIABILITY ARISING OUT OF THE APPLICATION OR USE OF ANY PRODUCT OR CIRCUIT DESCRIBED HEREIN; NEITHER DOES IT CONVEY ANY LICENSE UNDER ITS PATENT RIGHTS, NOR THE RIGHTS OF OTHERS. THESE SPECIFICATIONS DO NOT EXPAND THE TERMS OF FAIRCHILD'S WORLDWIDE TERMS AND CONDITIONS, SPECIFICALLY THE WARRANTY THEREIN, WHICH COVERS THESE PRODUCTS.

LIFE SUPPORT POLICY

FAIRCHILD'S PRODUCTS ARE NOT AUTHORIZED FOR USE AS CRITICAL COMPONENTS IN LIFE SUPPORT DEVICES OR SYSTEMS WITHOUT THE EXPRESS WRITTEN APPROVAL OF FAIRCHILD SEMICONDUCTOR CORPORATION.

As used herein:

1. Life support devices or systems are devices or systems which, (a) are intended for surgical implant into the body or (b) support or sustain life, and (c) whose failure to perform when properly used in accordance with instructions for use provided in the labeling, can be reasonably expected to result in a significant injury of the user.
2. A critical component in any component of a life support, device, or system whose failure to perform can be reasonably expected to cause the failure of the life support device or system, or to affect its safety or effectiveness.

ANTI-COUNTERFEITING POLICY

Fairchild Semiconductor Corporation's Anti-Counterfeiting Policy. Fairchild's Anti-Counterfeiting Policy is also stated on our external website, www.fairchildsemi.com, under Sales Support.

Counterfeiting of semiconductor parts is a growing problem in the industry. All manufacturers of semiconductor products are experiencing counterfeiting of their parts. Customers who inadvertently purchase counterfeit parts experience many problems such as loss of brand reputation, substandard performance, failed applications, and increased cost of production and manufacturing delays. Fairchild is taking strong measures to protect ourselves and our customers from the proliferation of counterfeit parts. Fairchild strongly encourages customers to purchase Fairchild parts either directly from Fairchild or from Authorized Fairchild Distributors who are listed by country on our web page cited above. Products customers buy either from Fairchild directly or from Authorized Fairchild Distributors are genuine parts, have full traceability, meet Fairchild's quality standards for handling and storage and provide access to Fairchild's full range of up-to-date technical and product information. Fairchild and our Authorized Distributors will stand behind all warranties and will appropriately address any warranty issues that may arise. Fairchild will not provide any warranty coverage or other assistance for parts bought from Unauthorized Sources. Fairchild is committed to combat this global problem and encourage our customers to do their part in stopping this practice by buying direct or from authorized distributors.

PRODUCT STATUS DEFINITIONS

Definition of Terms

Datasheet Identification	Product Status	Definition
Advance Information	Formative / In Design	Datasheet contains the design specifications for product development. Specifications may change in any manner without notice.
Preliminary	First Production	Datasheet contains preliminary data; supplementary data will be published at a later date. Fairchild Semiconductor reserves the right to make changes at any time without notice to improve design.
No Identification Needed	Full Production	Datasheet contains final specifications. Fairchild Semiconductor reserves the right to make changes at any time without notice to improve the design.
Obsolete	Not In Production	Datasheet contains specifications on a product that is discontinued by Fairchild Semiconductor. The datasheet is for reference information only.

Rev. 161