

NB3Nxxxxx - VCXO Series

3.3V PureEdge™ VCXO Clock Generator with Differential LVPECL Outputs

Description

The NB3NXXXXXX – series voltage–controlled crystal oscillator (VCXO) devices are designed to meet today’s requirements for 3.3 V LVPECL clock generation applications. These devices use an external high Q fundamental mode pullable crystal and Phase Locked Loop (PLL) multiplier to provide a wide range of frequencies from 60 MHz to 700 MHz (factory configurable per user specifications) with a pullable range of ± 100 ppm. The silicon–based PureEdge products provides users with exceptional frequency stability and reliability. They produce an ultra low jitter and phase noise LVPECL differential output. The NB3NXXXXXX – series are members of ON Semiconductor’s PureEdge clock family that provides accurate and precision clock generation solutions.

Available in the industry standard 4 mm x 4 mm QFN–20 package.

Features

- LVPECL Differential Output
- Operating Range: 3.3 V $\pm 10\%$
- Ultra Low Jitter and Phase Noise – 0.5 ps (12 kHz – 20 MHz)
- 245 ps Typical Rise and Fall Times
- Factory Configurable Frequencies from 60 MHz to 700 MHz (see Standard Frequencies in the Ordering Information Table in page 5)
- Pullable Range Minimum of ± 100 ppm
- Control Voltage with Positive Slope
- -40°C to $+85^{\circ}\text{C}$ Ambient Operating Temperature
- These Devices are Pb–Free and are RoHS Compliant

Applications

- Networking
- SONET
- 10 Gigabit Ethernet
- Networking Base Stations
- Broadcasting



ON Semiconductor®

<http://onsemi.com>

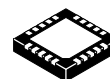

QFN20
MN SUFFIX
CASE 485E

MARKING DIAGRAM

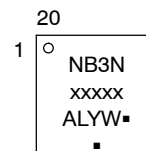

XXXXX = Frequency XXX.XX
A = Assembly Location
L, WL = Wafer Lot
Y = Year
W, WW = Work Week
G or ■ = Pb–Free Package

(*Note: Microdot may be in either location)

*For additional marking information, refer to Application Note AND8002/D.

ORDERING INFORMATION

See detailed ordering and shipping information in the package dimensions section on page 5 of this data sheet.

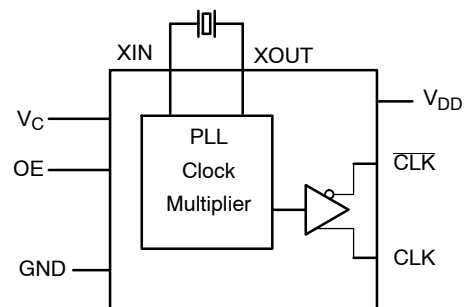

Figure 1. Simplified Block Diagram of NB3Nxxxxx

NB3Nxxxxx – VCXO Series

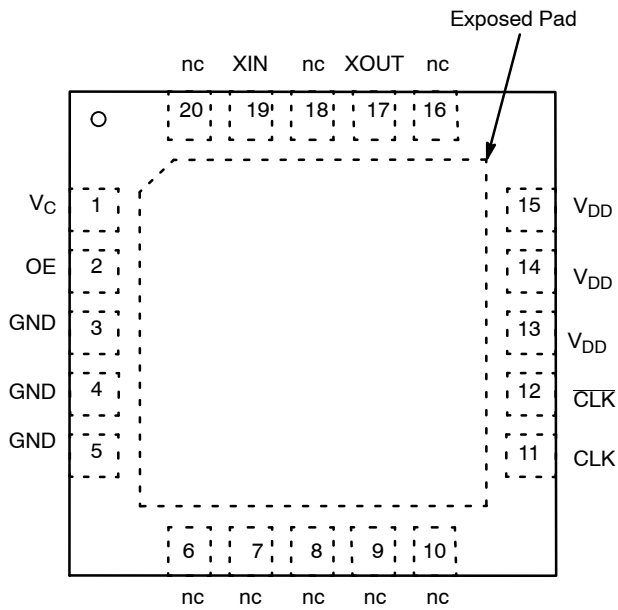

Figure 2. QFN-20 Pinout (Top View)

Table 1. OUTPUT ENABLE TRI-STATE FUNCTION

OE	Output Pins Function
Open	Active
High	Active
Low	High Z

Table 2. PIN DESCRIPTION

Pin	Name	I/O	Description
1	VC	Analog Input	Analog control voltage input pin that adjusts output oscillation frequency. $f_0 = V_C = 1.65 \text{ V}$. Control voltage has a positive slope with a linearity of $\pm 10\%$; $V_C = 1.65 \text{ V} \pm 1 \text{ V}$.
2	OE	LVTTTL / LVCMOS Input	Output Enable Pin. When left floating pin defaults to logic HIGH and output is active. See OE pin description Table 1.
3	GND	Ground	Negative Supply Voltage
4	GND	Ground	Negative Supply Voltage
5	GND	Ground	Negative Supply Voltage
6	nc	No connect	
7	nc	No connect	
8	nc	No connect	
9	nc	No connect	
10	nc	No connect	
11	CLK	LVPECL Output	Non-inverted Differential Output. Typically Terminated with 50Ω Resistor to $V_{DD} - 2 \text{ V}$.
12	CLK-bar	LVPECL Output	Inverted Differential Output. Typically Terminated with 50Ω Resistor to $V_{DD} - 2 \text{ V}$.
13	VDD	Power Supply	3.3 V Positive Supply Voltage
14	VDD	Power Supply	3.3 V Positive Supply Voltage
15	VDD	Power Supply	3.3 V Positive Supply Voltage
16	nc	No connect	
17	XOUT	Crystal	Crystal Input. This pin forms an oscillator when connected to an external parallel-resonant crystal.
18	nc	No connect	
19	XIN	Crystal	Crystal Input. This pin forms an oscillator when connected to an external parallel-resonant crystal.

NB3Nxxxxx – VCXO Series

Table 2. PIN DESCRIPTION

Pin	Name	I/O	Description
20	nc	No connect	
–	EP		The Exposed Pad (EP) on the QFN-20 package bottom is thermally connected to the die for improved heat transfer out of package. The exposed pad must be attached to a heat-sinking conduit. The pad is electrically connected to the die, and must be electrically and thermally connected to GND on the PC board.

1. All VDD and GND pins must be externally connected to a power supply for proper operation.

Table 3. ATTRIBUTES

Characteristics	Value
Internal Default State Resistor (OE)	170 k Ω
ESD Protection Human Body Model	2 kV
Machine Model	200 V
Moisture Sensitivity, Indefinite Time Out of Drypack (Note 2)	Level 1
Flammability Rating Oxygen Index: 28 to 34	UL 94 V-0 @ 0.125 in
Transistor Count	3510 Devices
Meets or Exceeds JEDEC Standard EIA/JESD78 IC Latchup Test	

2. For additional information, see Application Note AND8003/D.

Table 4. MAXIMUM RATINGS

Symbol	Parameter	Condition 1	Condition 1	Rating	Unit
V _{DD}	Positive Power Supply	GND = 0 V		4.6	V
V _{IN}	Control Input (V _C and OE)		V _{IN} ≤ V _{DD} + 200 mV V _{IN} ≥ GND – 200 mV		V
I _{OUT}	LVPECL Output Current	Continuous Surge		25 50	mA
T _A	Operating Temperature Range			–40 to +85	°C
T _{stg}	Storage Temperature Range			–55 to +120	°C
θ_{JA}	Thermal Resistance (Junction-to-Ambient)	0 lfpm 500 lfpm	QFN-20 QFN-20	47 33	°C/W
θ_{JC}	Thermal Resistance (Junction-to-Case) (Note 3)	Standard Board	QFN-20	18	°C/W
T _{sol}	Wave Solder Pb-Free			265	°C

Stresses exceeding Maximum Ratings may damage the device. Maximum Ratings are stress ratings only. Functional operation above the Recommended Operating Conditions is not implied. Extended exposure to stresses above the Recommended Operating Conditions may affect device reliability.

3. JEDEC standard multilayer board – 2S2P (2 signal, 2 power) with 8 filled thermal vias under exposed pad.

Table 5. RECOMMENDED CRYSTAL PARAMETERS

Crystal Type	Fundamental AT-Cut
Frequency	Various – Device dependent; see AC Table
Load Capacitance	16 pF
Shunt Capacitance, C0	3.2 pF typical
Motional Capacitance (C1)	12 fF typical
Capacitance Ratio (C0/C1)	260 typical
ESR (Equivalent Series Resistance)	25 Ω max; 5 Ω typical

NB3Nxxxxx – VCXO Series

Table 6. DC CHARACTERISTICS ($V_{DD} = 3.3 \text{ V} \pm 10\%$, $GND = 0 \text{ V}$, $T_A = -40^\circ\text{C}$ to $+85^\circ\text{C}$) (Note 4)

Symbol	Characteristic	Min	Typ	Max	Unit
IDD	Power Supply Current		90	110	mA
VIH	Input HIGH Voltage, OE	2000		V_{DD}	mV
VIL	Input LOW Voltage, OE	$GND - 200$		800	mV
IIH	Input HIGH Current, OE	-100		+100	uA
IIL	Input LOW Current, OE	-100		+100	uA
VOH	Output HIGH Voltage	$V_{DD} - 1195$		$V_{DD} - 945$	mV
VOL	Output LOW Voltage	$V_{DD} - 1945$		$V_{DD} - 1600$	mV
VOUTPP	Output Voltage Amplitude		700		mV

4. Measurement taken with outputs terminated with 50Ω to $V_{DD} - 2.0 \text{ V}$. See Figure 3.

Table 7. AC CHARACTERISTICS ($V_{DD} = 3.3 \pm 10\%$, $GND = 0 \text{ V}$, $T_A = -40^\circ\text{C}$ to $+85^\circ\text{C}$)

Symbol	Characteristic	Conditions	Min	Typ	Max	Unit
f_{CLKOUT}	Output Clock Frequency	Crystal $f_{ref} = 28.276363 \text{ MHz}$	NB3N15552		155.52	MHz
		Crystal $f_{ref} = 28.409090 \text{ MHz}$	NB3N15625		156.25	
		Crystal $f_{ref} = 30.703125 \text{ MHz}$	NB3N49152		491.52	
		Crystal $f_{ref} = 28.276363 \text{ MHz}$	NB3N62208		622.08	
$t_{jit(cp)}$	RMS Phase Jitter	12 kHz to 20 MHz		0.5	0.9	ps
t_{jitter}	Cycle to Cycle, RMS	1000 Cycles		2	8	ps
	Cycle to Cycle, Peak-to-Peak	1000 Cycles		10	30	
	Period, RMS	10,000 Cycles		1	4	
	Period, Peak-to-Peak	10,000 Cycles		6	20	
$t_{OE/OD}$	Output Enable/Disable Time				200	ns
F_P	Crystal Pull ability (Note 5)	$0 \leq V_C \leq 3.3 \text{ V}$	± 100			ppm
$V_{C(bw)}$	Control Voltage Bandwidth	-3 dB	20			kHz
t_{DUTY_CYCLE}	Output Clock Duty Cycle (Measured at Cross Point)		45	50	55	%
t_R	Output Rise Time (20% and 80%)			245	400	ps
t_F	Output Fall Time (80% and 20%)			245	400	ps
t_{start}	Start-up Time			1	5	ms

5. Gain transfer is positive with a rate of 130 ppm/V.

Table 8. PHASE NOISE PERFORMANCE

Parameter	Characteristic	Condition	155.52 MHz	156.25 MHz	491.52 MHz	622.08 MHz	Unit
θ_{NOISE}	Output Phase-Noise Performance	100 Hz offset	-82	-82	-72	-70	dBc/Hz
		1 kHz offset	-106	-106	-96	-94	dBc/Hz
		10 kHz offset	-126	-126	-116	-114	dBc/Hz
		100 kHz offset	-128	-128	-119	-116	dBc/Hz
		1 MHz offset	-135	-135	-125	-123	dBc/Hz
		10 MHz offset	-159	-159	-151	-149	dBc/Hz

NB3Nxxxxx – VCXO Series

ORDERING INFORMATION

Device	Frequency (MHz)	Package	Shipping†
NB3N15552MNG	155.52	QFN-20 (Pb-Free)	92 Units / Rail
NB3N15552MNTXG	155.52	QFN-20 (Pb-Free)	3000 / Tape & Reel
NB3N15625MNG	156.25	QFN-20 (Pb-Free)	92 Units / Rail
NB3N15625MNTXG	156.25	QFN-20 (Pb-Free)	3000 / Tape & Reel
NB3N49152MNG	491.52	QFN-20 (Pb-Free)	92 Units / Rail
NB3N49152MNTXG	491.52	QFN-20 (Pb-Free)	3000 / Tape & Reel
NB3N62208MNG	622.08	QFN-20 (Pb-Free)	92 Units / Rail
NB3N62208MNTXG	622.08	QFN-20 (Pb-Free)	3000 / Tape & Reel

†For information on tape and reel specifications, including part orientation and tape sizes, please refer to our Tape and Reel Packaging Specifications Brochure, BRD8011/D.

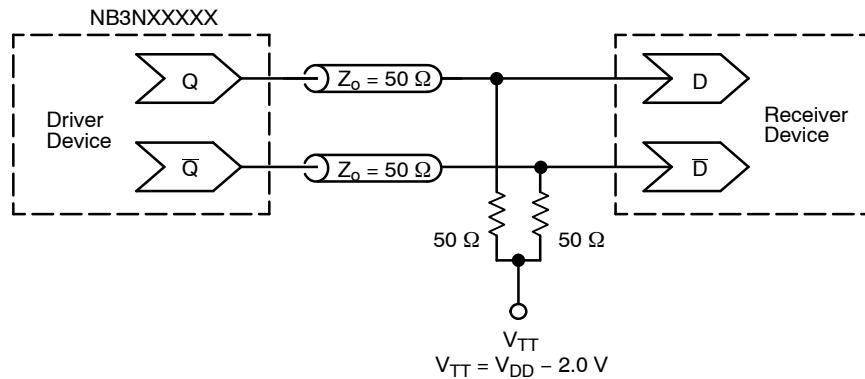
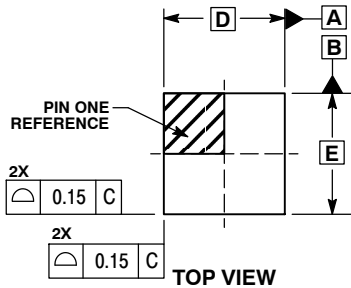

Figure 3. Typical Termination for Output Driver and Device Evaluation
 (See Application Note AND8020/D – Termination of ECL Logic Devices.)

NB3Nxxxxx – VCXO Series

PACKAGE DIMENSIONS

QFN20, 4x4, 0.5P
CASE 485E-01
ISSUE B



TOP VIEW

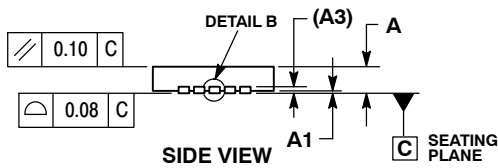

SIDE VIEW

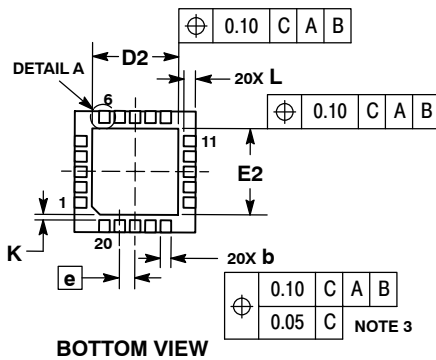

BOTTOM VIEW

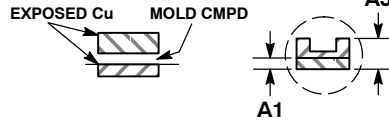

DETAIL B
OPTIONAL CONSTRUCTIONS

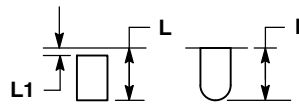

DETAIL A
OPTIONAL CONSTRUCTIONS

NOTES:

1. DIMENSIONING AND TOLERANCING PER ASME Y14.5M, 1994.
2. CONTROLLING DIMENSION: MILLIMETERS.
3. DIMENSION b APPLIES TO PLATED TERMINAL AND IS MEASURED BETWEEN 0.15 AND 0.30 MM FROM THE TERMINAL TIP.
4. COPLANARITY APPLIES TO THE EXPOSED PAD AS WELL AS THE TERMINALS.

DIM	MILLIMETERS	
	MIN	MAX
A	0.80	1.00
A1	---	0.05
A3	0.20	REF
b	0.20	0.30
D	4.00	BSC
D2	2.60	2.90
E	4.00	BSC
E2	2.60	2.90
e	0.50	BSC
K	0.20	REF
L	0.35	0.45
L1	0.00	0.15

SOLDERING FOOTPRINT*

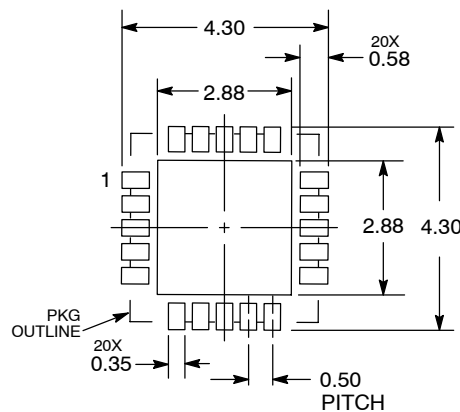

DIMENSIONS: MILLIMETERS

*For additional information on our Pb-Free strategy and soldering details, please download the ON Semiconductor Soldering and Mounting Techniques Reference Manual, SOLDERM/D.

PureEdge is a trademark of Semiconductor Components Industries, LLC (SCILLC).

ON Semiconductor and are registered trademarks of Semiconductor Components Industries, LLC (SCILLC). SCILLC reserves the right to make changes without further notice to any products herein. SCILLC makes no warranty, representation or guarantee regarding the suitability of its products for any particular purpose, nor does SCILLC assume any liability arising out of the application or use of any product or circuit, and specifically disclaims any and all liability, including without limitation special, consequential or incidental damages. "Typical" parameters which may be provided in SCILLC data sheets and/or specifications can and do vary in different applications and actual performance may vary over time. All operating parameters, including "Typicals" must be validated for each customer application by customer's technical experts. SCILLC does not convey any license under its patent rights nor the rights of others. SCILLC products are not designed, intended, or authorized for use as components in systems intended for surgical implant into the body, or other applications intended to support or sustain life, or for any other application in which the failure of the SCILLC product could create a situation where personal injury or death may occur. Should Buyer purchase or use SCILLC products for any such unintended or unauthorized application, Buyer shall indemnify and hold SCILLC and its officers, employees, subsidiaries, affiliates, and distributors harmless against all claims, costs, damages, and expenses, and reasonable attorney fees arising out of, directly or indirectly, any claim of personal injury or death associated with such unintended or unauthorized use, even if such claim alleges that SCILLC was negligent regarding the design or manufacture of the part. SCILLC is an Equal Opportunity/Affirmative Action Employer. This literature is subject to all applicable copyright laws and is not for resale in any manner.

PUBLICATION ORDERING INFORMATION

LITERATURE FULFILLMENT:
Literature Distribution Center for ON Semiconductor
P.O. Box 5163, Denver, Colorado 80217 USA
Phone: 303-675-2175 or 800-344-3860 Toll Free USA/Canada
Fax: 303-675-2176 or 800-344-3867 Toll Free USA/Canada
Email: orderlit@onsemi.com

N. American Technical Support: 800-282-9855 Toll Free USA/Canada
Europe, Middle East and Africa Technical Support:
Phone: 421 33 790 2910
Japan Customer Focus Center
Phone: 81-3-5817-1050

ON Semiconductor Website: www.onsemi.com
Order Literature: <http://www.onsemi.com/orderlit>
For additional information, please contact your local Sales Representative