

# MMT05A230T3, MMT05A260T3, MMT05A310T3


Preferred Devices

## Thyristor Surge Protectors

### High Voltage Bidirectional TSPD

These Thyristor Surge Protective devices (TSPD) prevent overvoltage damage to sensitive circuits by lightning, induction and power line crossings. They are breakover-triggered crowbar protectors. Turn-off occurs when the surge current falls below the holding current value.

Secondary protection applications for electronic telecom equipment at customer premises.

- High Surge Current Capability: **50 Amps** 10 x 1000  $\mu$ sec; for Controlled Temperature Environments in the **SMA** package
- The MMT05A230T3 Series is used to help equipment meet various regulatory requirements including: Telcordia 1089, ITU K.20 & K.21, IEC 950 and FCC Part 68
- Bidirectional Protection in a Single Device
- Little Change of Voltage Limit with Transient Amplitude or Rate
- Freedom from Wearout Mechanisms Present in Non-Semiconductor Devices
- Fail-Safe, Shorts When Overstressed, Preventing Continued Unprotected Operation
- Surface Mount Technology (SMT)
-  Indicates UL Registered – File #E210057
- Pb-Free Packages are Available

#### MAXIMUM RATINGS ( $T_J = 25^\circ\text{C}$ unless otherwise noted)

Rating	Symbol	Value	Unit
Off-State Voltage – Maximum MMT05A230T3 MMT05A260T3 MMT05A310T3	$V_{DM}$	$\pm 170$ $\pm 200$ $\pm 270$	Volts
Maximum Pulse Surge Short Circuit Current Non-Repetitive Double Exponential Decay Waveform (Notes 1 and 2) 8 x 20 $\mu$ sec 10 x 160 $\mu$ sec 10 x 560 $\mu$ sec 10 x 1000 $\mu$ sec	$I_{PPS1}$ $I_{PPS2}$ $I_{PPS3}$ $I_{PPS4}$	$\pm 150$ $\pm 100$ $\pm 70$ $\pm 50$	A(pk)
Maximum Non-Repetitive Rate of Change of On-State Current Double Exponential Waveform, $I_{PK} = 50$ A, $P_W = 15$ $\mu$ s	di/dt	$\pm 100$	A/ $\mu$ s

Maximum ratings are those values beyond which device damage can occur. Maximum ratings applied to the device are individual stress limit values (not normal operating conditions) and are not valid simultaneously. If these limits are exceeded, device functional operation is not implied, damage may occur and reliability may be affected.

1. Allow cooling before testing second polarity.
2. Measured under pulse conditions to reduce heating.



ON Semiconductor®

<http://onsemi.com>

**BIDIRECTIONAL TSPD  
50 AMP SURGE  
265 thru 365 VOLTS**



**SMA  
(No Polarity)  
CASE 403D**

#### MARKING DIAGRAM



xxx = Specific Device Code  
A = Assembly Location  
Y = Year  
WW = Work Week  
▪ = Pb-Free Package

#### ORDERING INFORMATION

See detailed ordering and shipping information in the package dimensions section on page 6 of this data sheet.

**Preferred** devices are recommended choices for future use and best overall value.

# MMT05A230T3, MMT05A260T3, MMT05A310T3

## THERMAL CHARACTERISTICS

Characteristic	Symbol	Max	Unit
Operating Temperature Range Blocking or Conducting State	$T_{J1}$	-40 to +125	°C
Overload Junction Temperature – Maximum Conducting State Only	$T_{J2}$	+175	°C
Instantaneous Peak Power Dissipation ( $I_{pk} = 50A, 10 \times 1000 \mu\text{sec} @ 25^\circ\text{C}$ )	$P_{PK}$	2000	W
Maximum Lead Temperature for Soldering Purposes 1/8" from Case for 10 Seconds	$T_L$	260	°C

## ELECTRICAL CHARACTERISTICS ( $T_J = 25^\circ\text{C}$ unless otherwise noted)

Devices are bidirectional. All electrical parameters apply to forward and reverse polarities.

Characteristics	Symbol	Min	Typ	Max	Unit
Breakover Voltage (Both polarities) ( $dv/dt = 100 \text{ V}/\mu\text{s}, I_{SC} = 1.0 \text{ A}, V_{dc} = 1000 \text{ V}$ )  (+65°C)	$V_{(BO)}$	-	-	265 320 365  280 340 400	Volts
Breakover Voltage (Both polarities) ( $f = 60 \text{ Hz}, I_{SC} = 1.0 \text{ A(rms)}, V_{OC} = 1000 \text{ V(rms)}, R_I = 1.0 \text{ k}\Omega, t = 0.5 \text{ cycle}$ ) (Note 3)  (+65°C)	$V_{(BO)}$	-	-	265 320 365  280 340 400	Volts
Breakover Voltage Temperature Coefficient	$dV_{(BO)}/dT_J$	-	0.08	-	%/°C
Breakdown Voltage ( $I_{(BR)} = 1.0 \text{ mA}$ ) Both polarities	$V_{(BR)}$	-	190 240 280	-	Volts
Off State Current ( $V_{D1} = 50 \text{ V}$ ) Both polarities ( $V_{D2} = V_{DM}$ ) Both polarities	$I_{D1}$ $I_{D2}$	-	-	2.0 5.0	$\mu\text{A}$
On-State Voltage ( $I_T = 1.0 \text{ A}$ ) ( $PW \leq 300 \mu\text{s}, \text{Duty Cycle} \leq 2\%$ ) (Note 3)	$V_T$	-	1.53	3.0	Volts
Breakover Current ( $f = 60 \text{ Hz}, V_{DM} = 1000 \text{ V(rms)}, R_S = 1.0 \text{ k}\Omega$ ) Both polarities	$I_{BO}$	-	230	-	mA
Holding Current (Both polarities) (Note 3) $V_S = 500 \text{ Volts}; I_T$ (Initiating Current) = $\pm 1.0 \text{ Amp}$	$I_H$	150	340	-	mA
Critical Rate of Rise of Off-State Voltage (Linear waveform, $V_D = \text{Rated } V_{BR}, T_J = 25^\circ\text{C}$ )	$dv/dt$	2000	-	-	$\text{V}/\mu\text{s}$
Capacitance ( $f = 1.0 \text{ MHz}, 50 \text{ Vdc}, 1.0 \text{ V(rms)}$ Signal) ( $f = 1.0 \text{ MHz}, 2.0 \text{ Vdc}, 1.0 \text{ V(rms)}$ Signal)	$C_O$	-	22 35	- 50	pF

3. Measured under pulse conditions to reduce heating.

# MMT05A230T3, MMT05A260T3, MMT05A310T3

## Voltage Current Characteristic of TSPD (Bidirectional Device)

Symbol	Parameter
$I_{D1}, I_{D2}$	Off State Leakage Current
$V_{D1}, V_{D2}$	Off State Blocking Voltage
$V_{BR}$	Breakdown Voltage
$V_{BO}$	Breakover Voltage
$I_{BO}$	Breakover Current
$I_H$	Holding Current
$V_{TM}$	On State Voltage

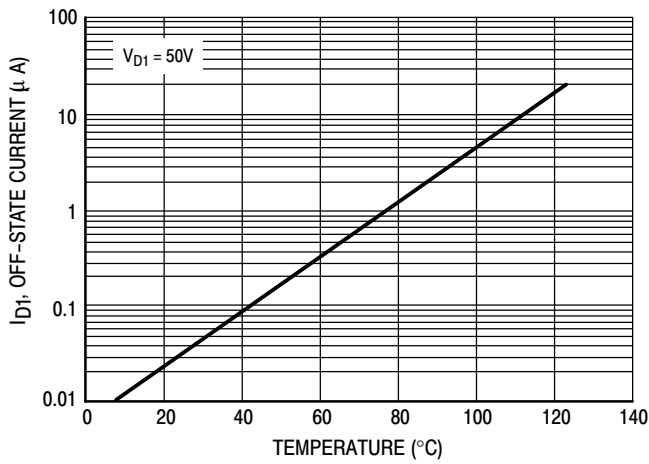
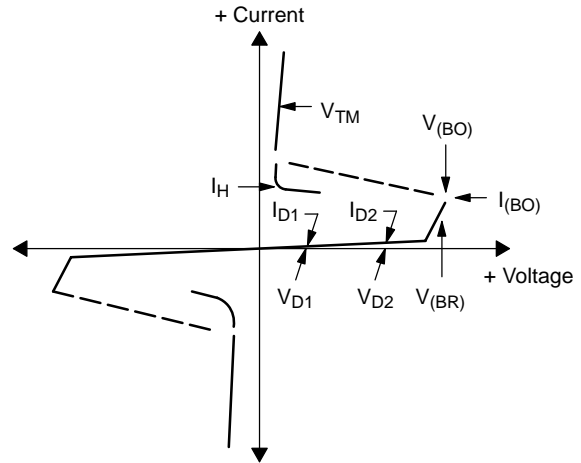


Figure 1. Off-State Current versus Temperature

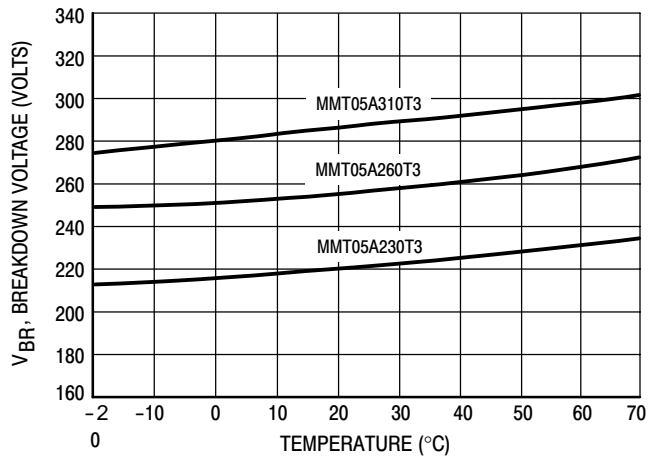
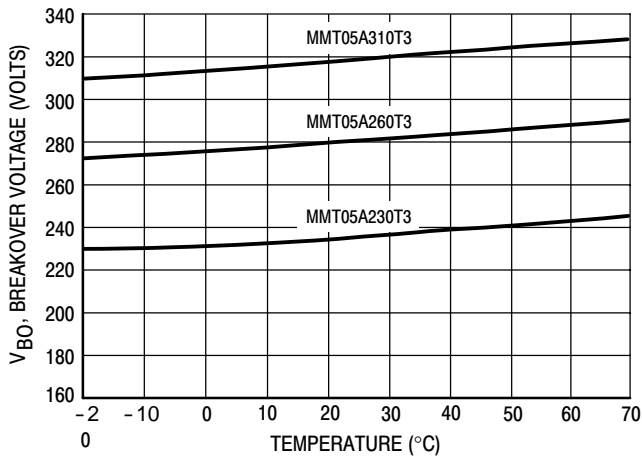
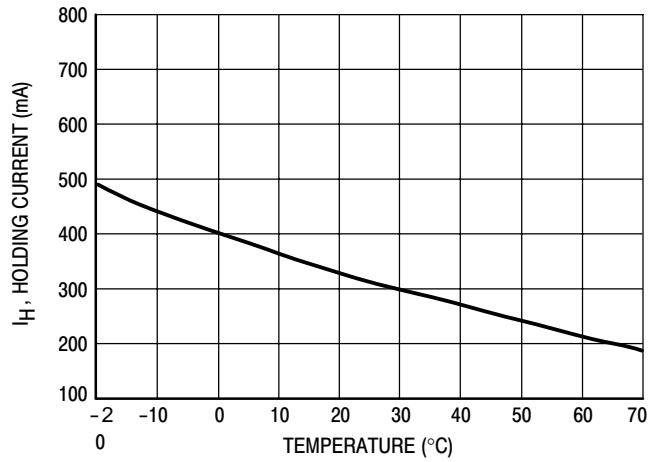


Figure 2. Typical Breakdown Voltage versus Temperature

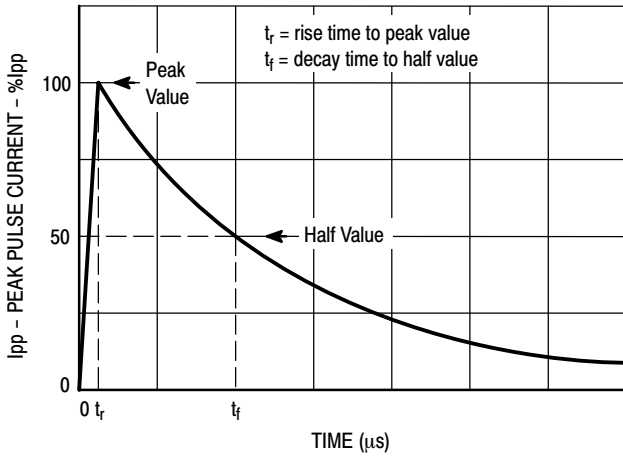
**MMT05A230T3, MMT05A260T3, MMT05A310T3**



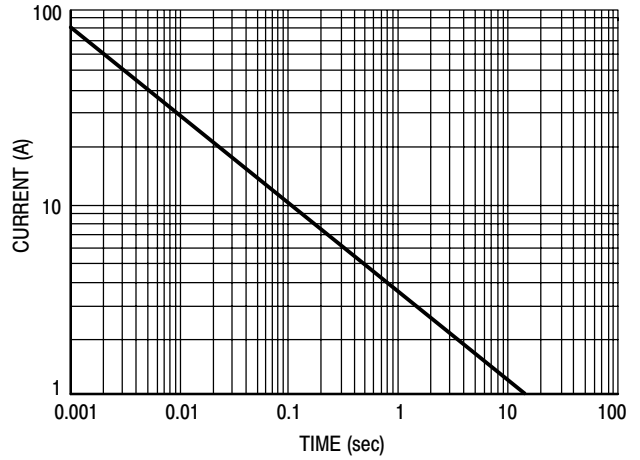
**Figure 3. Typical Breakover Voltage versus Temperature**



**Figure 4. Typical Holding Current versus Temperature**

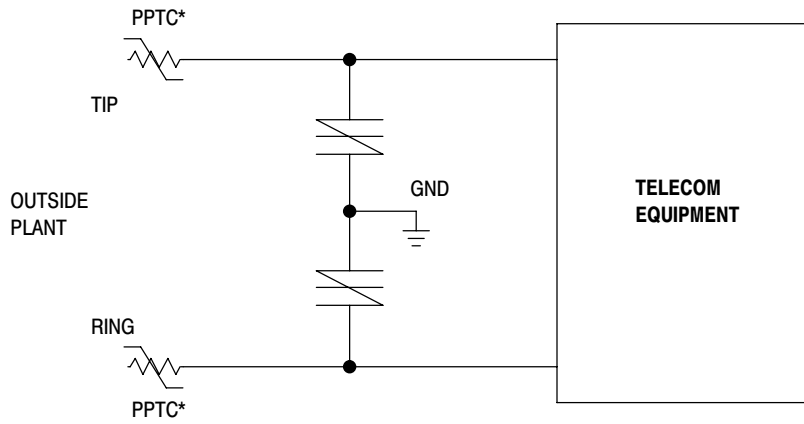
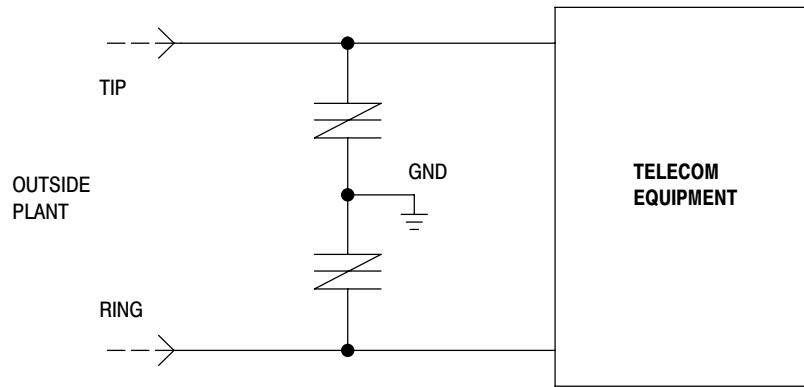


**Figure 5. Exponential Decay Pulse Waveform**

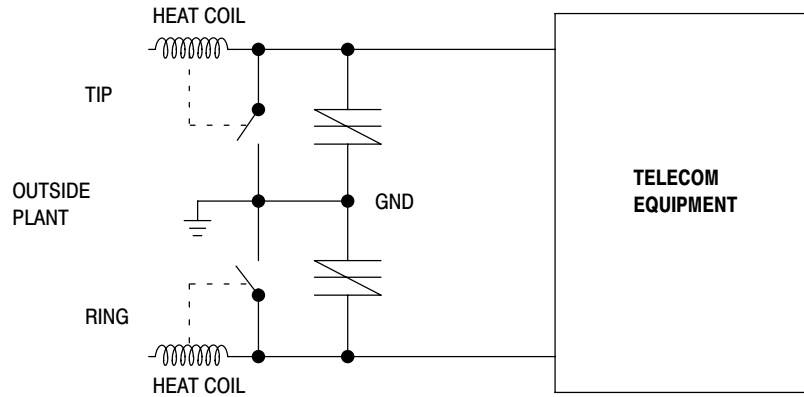


**Figure 6. Peak Surge On-State Current versus Surge Current Duration, Sinusoidal Waveform**

# MMT05A230T3, MMT05A260T3, MMT05A310T3



\*Polymeric PTC (positive temperature coefficient) overcurrent protection device



# MMT05A230T3, MMT05A260T3, MMT05A310T3

## ORDERING INFORMATION

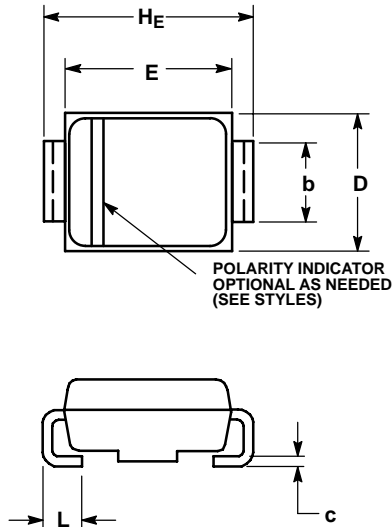
Device	Package	Device Marking	Shipping†
MMT05A230T3	SMA	PBF	5000 / Tape & Reel (12 mm Reel)
MMT05A230T3G	SMA (Pb-Free)	PBF	5000 / Tape & Reel (12 mm Reel)
MMT05A260T3	SMA	PBG	5000 / Tape & Reel (12 mm Reel)
MMT05A260T3G	SMA (Pb-Free)	PBG	5000 / Tape & Reel (12 mm Reel)
MMT05A310T3	SMA	PBJ	5000 / Tape & Reel (12 mm Reel)
MMT05A310T3G	SMA (Pb-Free)	PBJ	5000 / Tape & Reel (12 mm Reel)

†For information on tape and reel specifications, including part orientation and tape sizes, please refer to our Tape and Reel Packaging Specifications Brochure, BRD8011/D.

# MMT05A230T3, MMT05A260T3, MMT05A310T3

## PACKAGE DIMENSIONS

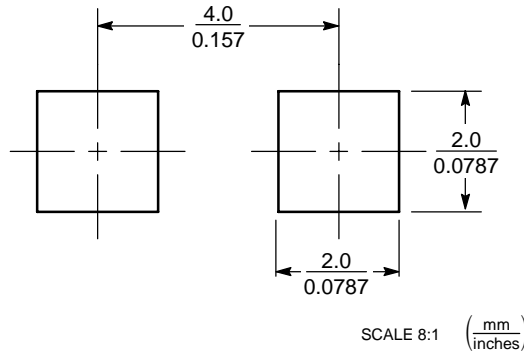
SMA  
CASE 403D-02  
ISSUE C



- NOTES:
1. DIMENSIONING AND TOLERANCING PER ANSI Y14.5M, 1982.
  2. CONTROLLING DIMENSION: INCH.
  3. 403D-01 OBSOLETE, NEW STANDARD IS 403D-02.

DIM	MILLIMETERS			INCHES		
	MIN	NOM	MAX	MIN	NOM	MAX
A	1.91	2.16	2.41	0.075	0.085	0.095
A1	0.05	0.10	0.15	0.002	0.004	0.006
b	1.27	1.45	1.63	0.050	0.057	0.064
c	0.15	0.28	0.41	0.006	0.011	0.016
D	2.29	2.60	2.92	0.090	0.103	0.115
E	4.06	4.32	4.57	0.160	0.170	0.180
HE	4.83	5.21	5.59	0.190	0.205	0.220
L	0.76	1.14	1.52	0.030	0.045	0.060

### SOLDERING FOOTPRINT\*



\*For additional information on our Pb-Free strategy and soldering details, please download the ON Semiconductor Soldering and Mounting Techniques Reference Manual, SOLDERRM/D.

ON Semiconductor and are registered trademarks of Semiconductor Components Industries, LLC (SCILLC). SCILLC reserves the right to make changes without further notice to any products herein. SCILLC makes no warranty, representation or guarantee regarding the suitability of its products for any particular purpose, nor does SCILLC assume any liability arising out of the application or use of any product or circuit, and specifically disclaims any and all liability, including without limitation special, consequential or incidental damages. "Typical" parameters which may be provided in SCILLC data sheets and/or specifications can and do vary in different applications and actual performance may vary over time. All operating parameters, including "Typicals" must be validated for each customer application by customer's technical experts. SCILLC does not convey any license under its patent rights nor the rights of others. SCILLC products are not designed, intended, or authorized for use as components in systems intended for surgical implant into the body, or other applications intended to support or sustain life, or for any other application in which the failure of the SCILLC product could create a situation where personal injury or death may occur. Should Buyer purchase or use SCILLC products for any such unintended or unauthorized application, Buyer shall indemnify and hold SCILLC and its officers, employees, subsidiaries, affiliates, and distributors harmless against all claims, costs, damages, and expenses, and reasonable attorney fees arising out of, directly or indirectly, any claim of personal injury or death associated with such unintended or unauthorized use, even if such claim alleges that SCILLC was negligent regarding the design or manufacture of the part. SCILLC is an Equal Opportunity/Affirmative Action Employer. This literature is subject to all applicable copyright laws and is not for resale in any manner.

### PUBLICATION ORDERING INFORMATION

**LITERATURE FULFILLMENT:**  
Literature Distribution Center for ON Semiconductor  
P.O. Box 61312, Phoenix, Arizona 85082-1312 USA  
**Phone:** 480-829-7710 or 800-344-3860 Toll Free USA/Canada  
**Fax:** 480-829-7709 or 800-344-3867 Toll Free USA/Canada  
**Email:** orderlit@onsemi.com

**N. American Technical Support:** 800-282-9855 Toll Free  
USA/Canada

**Japan:** ON Semiconductor, Japan Customer Focus Center  
2-9-1 Kamimeguro, Meguro-ku, Tokyo, Japan 153-0051  
**Phone:** 81-3-5773-3850

**ON Semiconductor Website:** <http://onsemi.com>

**Order Literature:** <http://www.onsemi.com/litorder>

For additional information, please contact your local Sales Representative.

**MMT05A230T3/D**