



# FDP047N08

## N-Channel PowerTrench® MOSFET

75V, 164A, 4.7mΩ

### Features

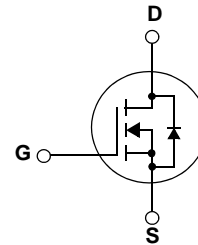
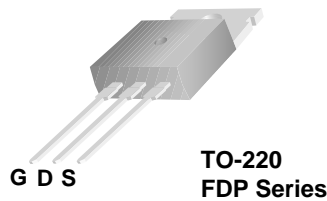
- $R_{DS(on)} = 3.8m\Omega$  (Typ.) @  $V_{GS} = 10V, I_D = 80A$
- Fast switching speed
- Low gate charge
- High performance trench technology for extremely low  $R_{DS(on)}$
- High power and current handling capability
- RoHS compliant

### Description

This N-Channel MOSFET is produced using Fairchild Semiconductor's advanced PowerTrench process that has been especially tailored to minimize the on-state resistance and yet maintain superior switching performance.

### Application

- DC to DC converters / Synchronous Rectification



### MOSFET Maximum Ratings $T_C = 25^\circ C$ unless otherwise noted\*

Symbol	Parameter	Conditions	Ratings	Units
$V_{DSS}$	Drain to Source Voltage		75	V
$V_{GSS}$	Gate to Source Voltage		$\pm 20$	V
$I_D$	Drain Current	- Continuous ( $T_C = 25^\circ C$ )	164*	A
		- Continuous ( $T_C = 100^\circ C$ )	116*	A
$I_{DM}$	Drain Current	- Pulsed (Note 1)	656	A
$E_{AS}$	Single Pulsed Avalanche Energy	(Note 2)	670	mJ
dv/dt	Peak Diode Recovery dv/dt	(Note 3)	3.0	V/ns
$P_D$	Power Dissipation	( $T_C = 25^\circ C$ )	268	W
		- Derate above $25^\circ C$	1.79	W/ $^\circ C$
$T_J, T_{STG}$	Operating and Storage Temperature Range		-55 to +175	$^\circ C$
$T_L$	Maximum Lead Temperature for Soldering Purpose, 1/8" from Case for 5 Seconds		300	$^\circ C$

\*Calculated continuous current based on maximum allowable junction temperature. Package limitation current is 80A.

### Thermal Characteristics

Symbol	Parameter	Ratings	Units
$R_{\theta JC}$	Thermal Resistance, Junction to Case	0.56	$^\circ C/W$
$R_{\theta CS}$	Thermal Resistance, Case to Sink Typ.	0.5	
$R_{\theta JA}$	Thermal Resistance, Junction to Ambient	62.5	

## Package Marking and Ordering Information $T_C = 25^\circ\text{C}$ unless otherwise noted

Device Marking	Device	Package	Reel Size	Tape Width	Quantity
FDP047N08	FDP047N08	TO-220	-	-	50

## Electrical Characteristics

Symbol	Parameter	Test Conditions	Min.	Typ.	Max.	Units
--------	-----------	-----------------	------	------	------	-------

### Off Characteristics

$BV_{DSS}$	Drain to Source Breakdown Voltage	$I_D = 250\mu\text{A}, V_{GS} = 0\text{V}, T_C = 25^\circ\text{C}$	75	-	-	V
$\frac{\Delta BV_{DSS}}{\Delta T_J}$	Breakdown Voltage Temperature Coefficient	$I_D = 250\mu\text{A}$ , Referenced to $25^\circ\text{C}$	-	0.02	-	$\text{V}/^\circ\text{C}$
$I_{DSS}$	Zero Gate Voltage Drain Current	$V_{DS} = 75\text{V}, V_{GS} = 0\text{V}$	-	-	1	$\mu\text{A}$
		$V_{DS} = 75\text{V}, T_C = 150^\circ\text{C}$	-	-	500	
$I_{GSS}$	Gate to Body Leakage Current	$V_{GS} = \pm 20\text{V}, V_{DS} = 0\text{V}$	-	-	$\pm 100$	nA

### On Characteristics

$V_{GS(th)}$	Gate Threshold Voltage	$V_{GS} = V_{DS}, I_D = 250\mu\text{A}$	2.5	3.5	4.5	V
$R_{DS(on)}$	Static Drain to Source On Resistance	$V_{GS} = 10\text{V}, I_D = 80\text{A}$	-	3.7	4.7	$\text{m}\Omega$
$g_{FS}$	Forward Transconductance	$V_{DS} = 10\text{V}, I_D = 80\text{A}$ (Note 4)	-	150	-	S

### Dynamic Characteristics

$C_{iss}$	Input Capacitance	$V_{DS} = 25\text{V}, V_{GS} = 0\text{V}$ $f = 1\text{MHz}$	-	7080	9415	$\mu\text{F}$
$C_{oss}$	Output Capacitance		-	870	1155	$\mu\text{F}$
$C_{rss}$	Reverse Transfer Capacitance		-	410	615	$\mu\text{F}$

### Switching Characteristics

$t_{d(on)}$	Turn-On Delay Time	$V_{DD} = 37.5\text{V}, I_D = 80\text{A}$ $R_{GEN} = 25\Omega, V_{GS} = 10\text{V}$	-	100	210	ns	
$t_r$	Turn-On Rise Time		-	147	304	ns	
$t_{d(off)}$	Turn-Off Delay Time		-	220	450	ns	
$t_f$	Turn-Off Fall Time		(Note 4, 5)	-	114	238	ns
$Q_{g(tot)}$	Total Gate Charge at 10V		-	117	152	nC	
$Q_{gs}$	Gate to Source Gate Charge	$V_{DS} = 60\text{V}, I_D = 80\text{A}$ $V_{GS} = 10\text{V}$	-	37	-	nC	
$Q_{gd}$	Gate to Drain "Miller" Charge	(Note 4, 5)	-	32	-	nC	

### Drain-Source Diode Characteristics

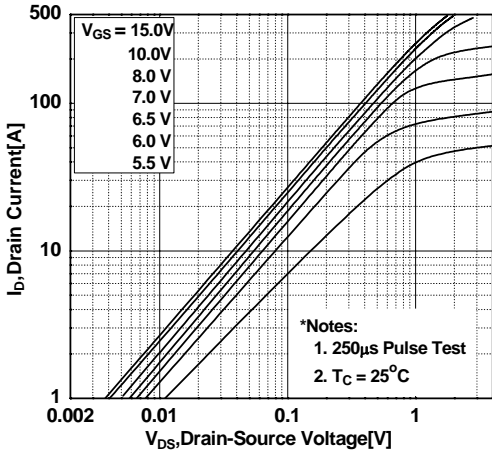
$I_S$	Maximum Continuous Drain to Source Diode Forward Current	-	-	164	A	
$I_{SM}$	Maximum Pulsed Drain to Source Diode Forward Current	-	-	656	A	
$V_{SD}$	Drain to Source Diode Forward Voltage	$V_{GS} = 0\text{V}, I_{SD} = 80\text{A}$	-	-	1.25	V
$t_{rr}$	Reverse Recovery Time	$V_{GS} = 0\text{V}, I_{SD} = 80\text{A}$	-	45	-	ns
$Q_{rr}$	Reverse Recovery Charge	$di_F/dt = 100\text{A}/\mu\text{s}$ (Note 4)	-	66	-	nC

#### Notes:

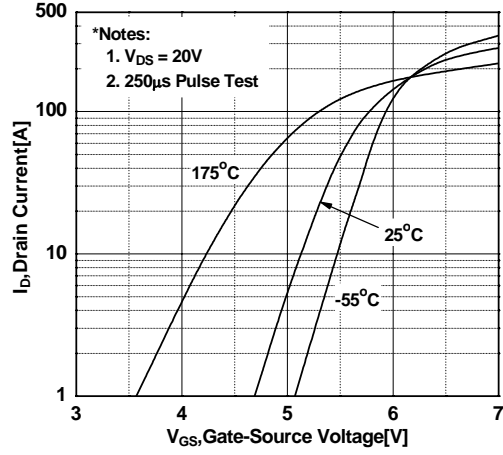
1. Repetitive Rating: Pulse width limited by maximum junction temperature
2.  $L = 0.21\text{mH}, I_{AS} = 80\text{A}, V_{DD} = 50\text{V}, R_G = 25\Omega$ , Starting  $T_J = 25^\circ\text{C}$
3.  $I_{SD} \leq 75\text{A}, di/dt \leq 200\text{A}/\mu\text{s}, V_{DD} \leq BV_{DSS}$ , Starting  $T_J = 25^\circ\text{C}$
4. Pulse Test: Pulse width  $\leq 300\mu\text{s}$ , Duty Cycle  $\leq 2\%$
5. Essentially Independent of Operating Temperature Typical Characteristics

## Typical Performance Characteristics

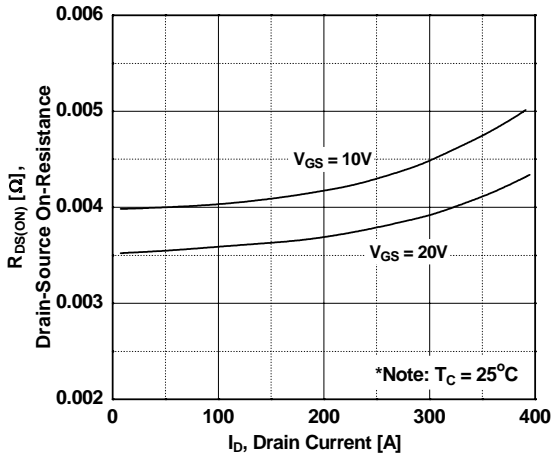
**Figure 1. On-Region Characteristics**



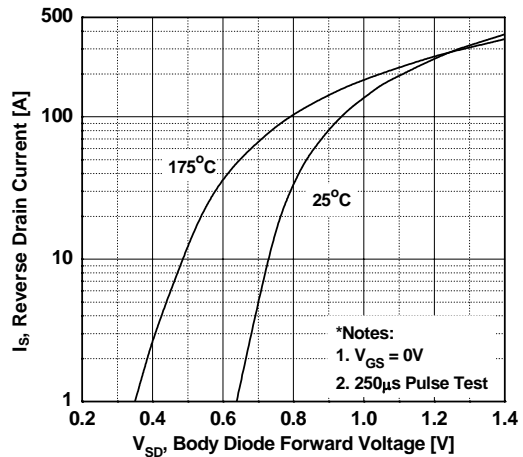
**Figure 2. Transfer Characteristics**



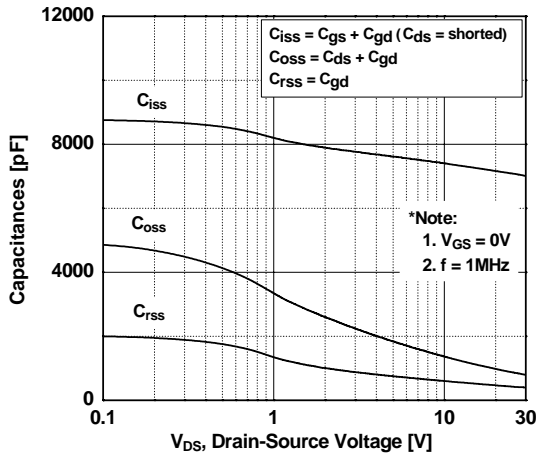
**Figure 3. On-Resistance Variation vs. Drain Current and Gate Voltage**



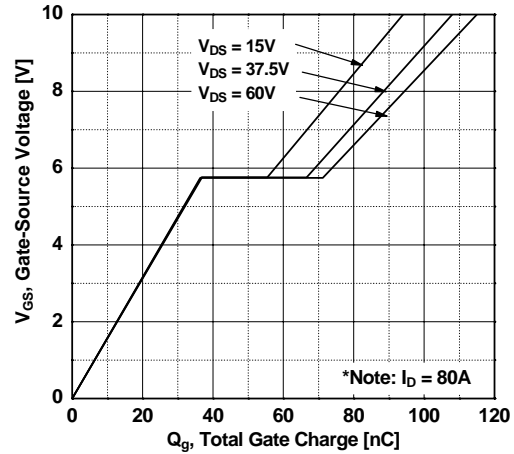
**Figure 4. Body Diode Forward Voltage Variation vs. Source Current and Temperature**



**Figure 5. Capacitance Characteristics**

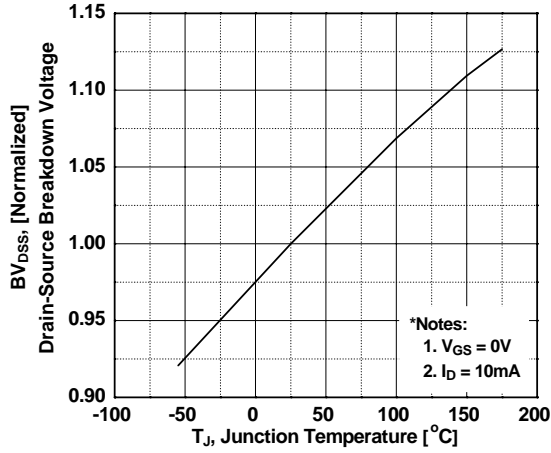


**Figure 6. Gate Charge Characteristics**

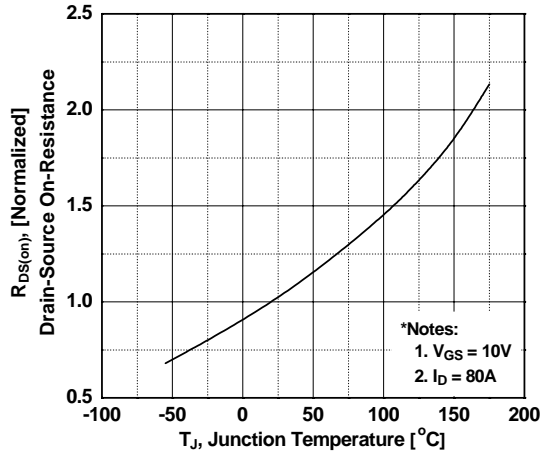


**Typical Performance Characteristics** (Continued)

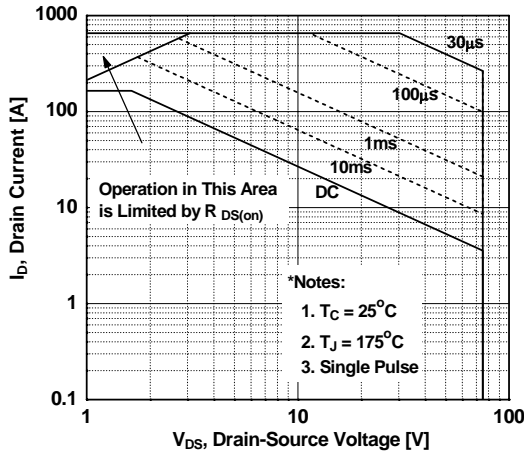
**Figure 7. Breakdown Voltage Variation vs. Temperature**



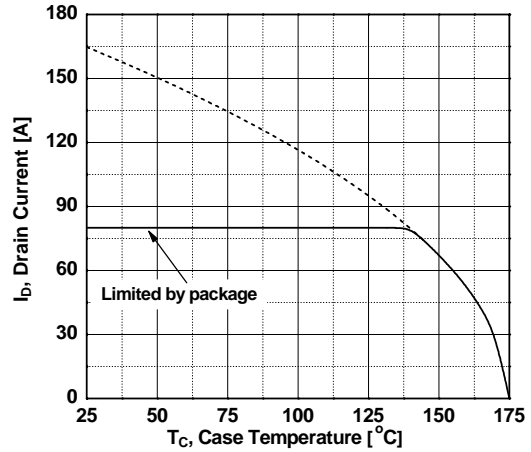
**Figure 8. On-Resistance Variation vs. Temperature**



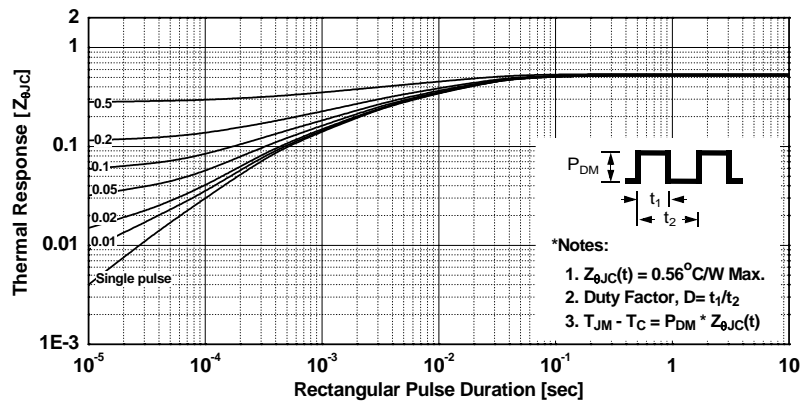
**Figure 9. Maximum Safe Operating Area**



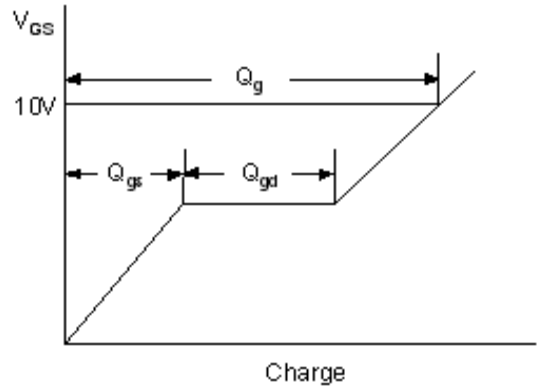
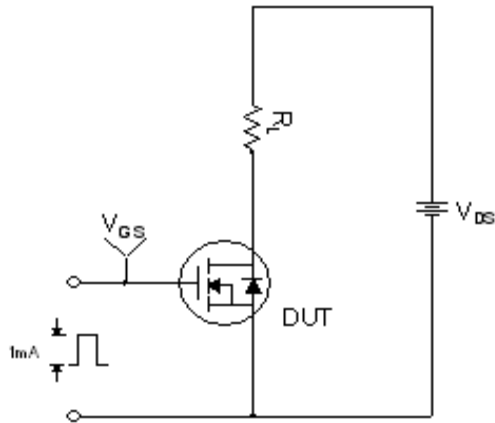
**Figure 10. Maximum Drain Current vs. Case Temperature**



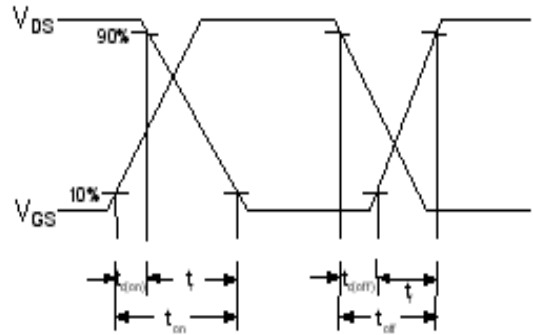
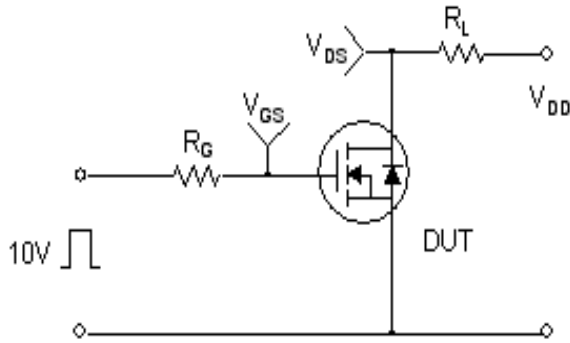
**Figure 11. Transient Thermal Response Curve**



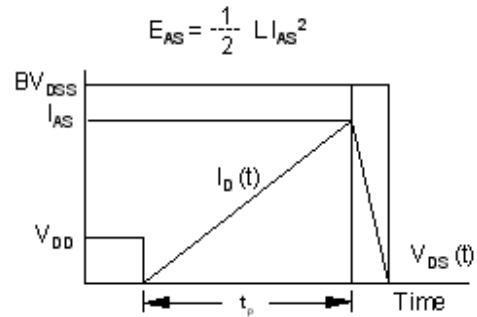
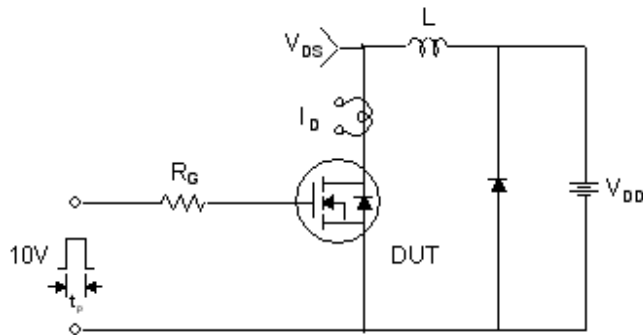
**Gate Charge Test Circuit & Waveform**



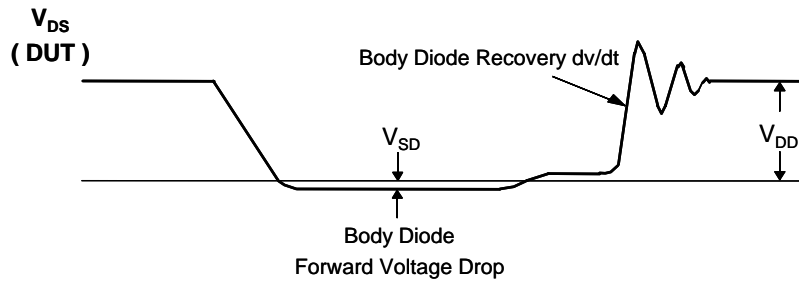
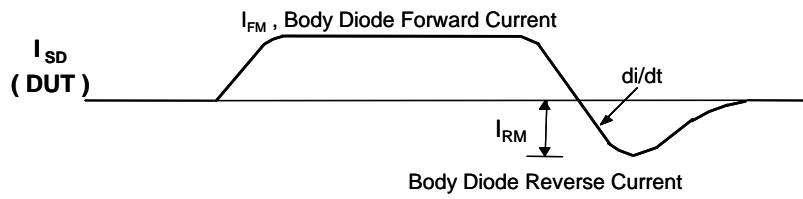
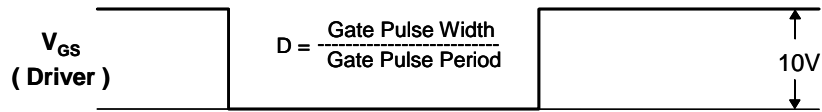
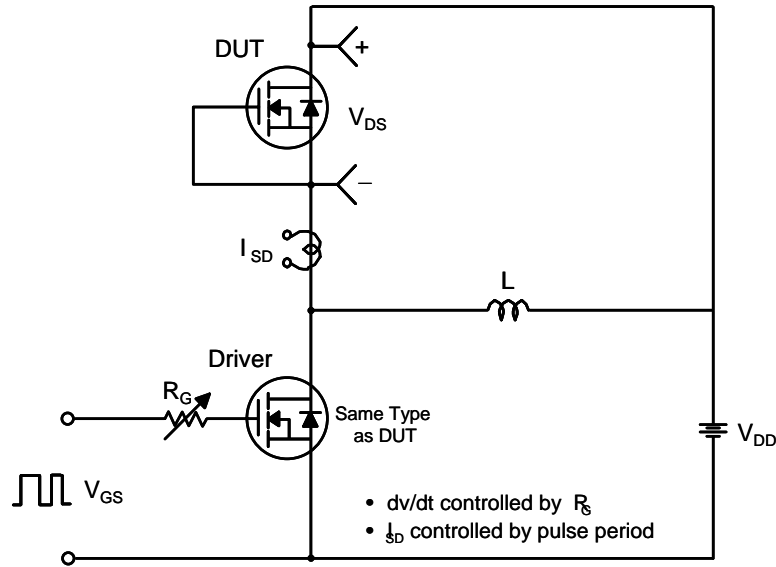
**Resistive Switching Test Circuit & Waveforms**



**Unclamped Inductive Switching Test Circuit & Waveforms**

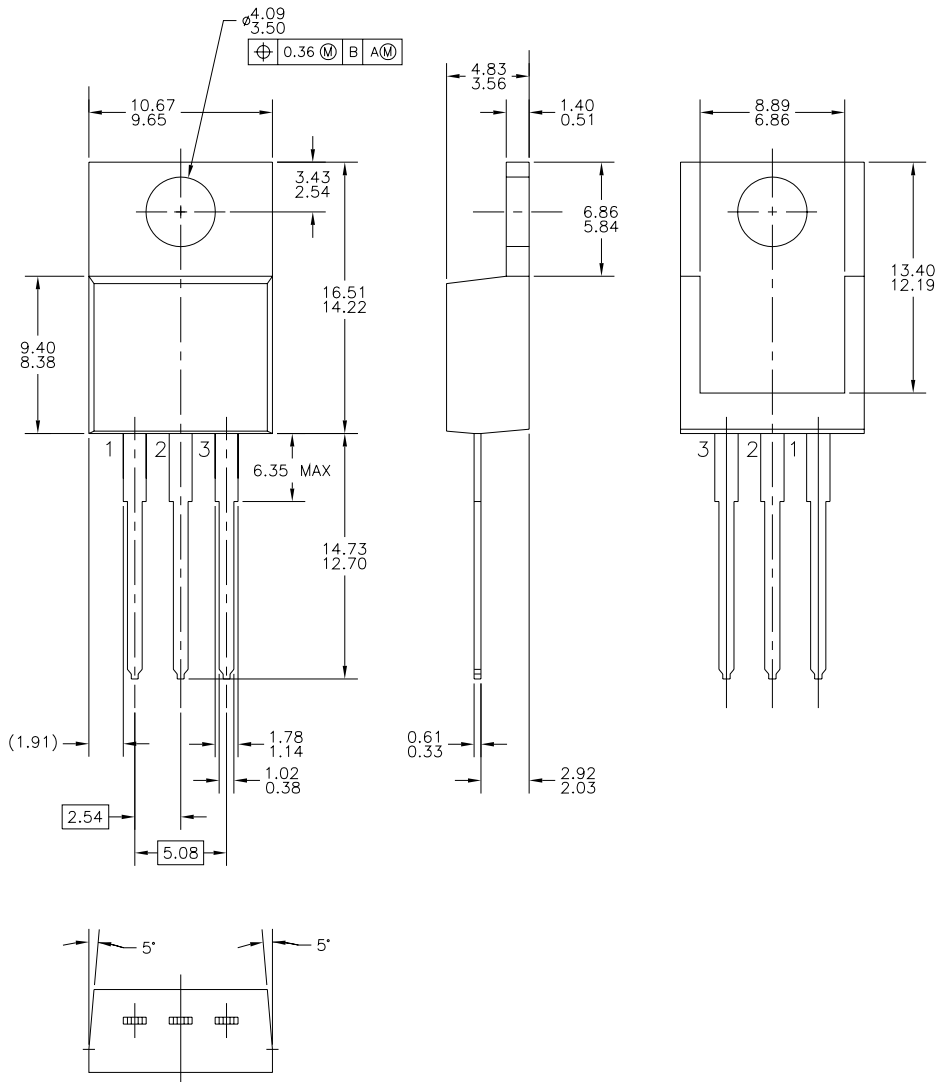


Peak Diode Recovery dv/dt Test Circuit & Waveforms



# Mechanical Dimensions

## TO-220

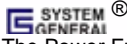




FDP047N08 N-Channel PowerTrench<sup>®</sup> MOSFET



**TRADEMARKS**

The following includes registered and unregistered trademarks and service marks, owned by Fairchild Semiconductor and/or its global subsidiaries, and is not intended to be an exhaustive list of all such trademarks.

- |   |   |  |   |
|---|---|--|---|
| ACEx <sup>®</sup>   | FPST <sup>™</sup>   | PDP-SPM <sup>™</sup>                   | SupreMOS <sup>™</sup>   |
| Build it Now <sup>™</sup>   | FRFET <sup>®</sup>  | Power220 <sup>®</sup>                  | SyncFET <sup>™</sup>  |
| CorePLUS <sup>™</sup>   | Global Power Resource <sup>SM</sup>   | POWEREDGE <sup>®</sup>                 |  SYSTEM GENFRAI <sup>®</sup> |
| CROSSVOLT <sup>™</sup>  | Green FPS <sup>™</sup>  | Power-SPM <sup>™</sup>                 | The Power Franchise <sup>®</sup>  |
| CTL <sup>™</sup>  | Green FPS <sup>™</sup> e-Series <sup>™</sup>                                      | PowerTrench <sup>®</sup>               | the <b>Power</b> franchise  |
| Current Transfer Logic <sup>™</sup>   | GTO <sup>™</sup>  | Programmable Active Droop <sup>™</sup> | TinyBoost <sup>™</sup>  |
| EcoSPARK <sup>®</sup>   | i-Lo <sup>™</sup>   | QFET <sup>®</sup>                      | TinyBuck <sup>™</sup>   |
| EZSWITCH <sup>™</sup> *   | IntelliMAX <sup>™</sup>   | QS <sup>™</sup>                        | TinyLogic <sup>®</sup>  |
|  EZ <sup>™</sup> | ISOPLANAR <sup>™</sup>  | QT Optoelectronics <sup>™</sup>        | TINYOPTO <sup>™</sup>   |
|  F <sup>®</sup>  | MegaBuck <sup>™</sup>   | Quiet Series <sup>™</sup>              | TinyPower <sup>™</sup>  |
| Fairchild <sup>®</sup>  | MICROCOUPLER <sup>™</sup>   | RapidConfigure <sup>™</sup>            | TinyPWM <sup>™</sup>  |
| Fairchild Semiconductor <sup>®</sup>  | MicroFET <sup>™</sup>   | SMART START <sup>™</sup>               | TinyWire <sup>™</sup>   |
| FACT Quiet Series <sup>™</sup>  | MicroPak <sup>™</sup>   | SPM <sup>®</sup>                       | µSerDes <sup>™</sup>  |
| FACT <sup>®</sup>   | MillerDrive <sup>™</sup>  | STEALTH <sup>™</sup>                   | UHC <sup>®</sup>  |
| FAST <sup>®</sup>   | Motion-SPM <sup>™</sup>   | SuperFET <sup>™</sup>                  | Ultra FRFET <sup>™</sup>  |
| FastvCore <sup>™</sup>  | OPTOLOGIC <sup>®</sup>  | SuperSOT <sup>™</sup> -3               | UniFET <sup>™</sup>   |
| FlashWriter <sup>®</sup> *  | OPTOPLANAR <sup>®</sup>   | SuperSOT <sup>™</sup> -6               | VCX <sup>™</sup>  |
|   |  | SuperSOT <sup>™</sup> -8               |   |

\* EZSWITCH<sup>™</sup> and FlashWriter<sup>®</sup> are trademarks of System General Corporation, used under license by Fairchild Semiconductor.

**DISCLAIMER**

FAIRCHILD SEMICONDUCTOR RESERVES THE RIGHT TO MAKE CHANGES WITHOUT NOTICE TO ANY PRODUCTS HEREIN TO IMPROVE RELIABILITY, FUNCTION, OR DESIGN. FAIRCHILD DOES NOT ASSUME ANY LIABILITY ARISING OUT OF THE APPLICATION OR USE OF ANY PRODUCT OR CIRCUIT DESCRIBED HEREIN; NEITHER DOES IT CONVEY ANY LICENSE UNDER ITS PATENT RIGHTS, NOR THE RIGHTS OF OTHERS. THESE SPECIFICATIONS DO NOT EXPAND THE TERMS OF FAIRCHILD'S WORLDWIDE TERMS AND CONDITIONS, SPECIFICALLY THE WARRANTY THEREIN, WHICH COVERS THESE PRODUCTS.

**LIFE SUPPORT POLICY**

FAIRCHILD'S PRODUCTS ARE NOT AUTHORIZED FOR USE AS CRITICAL COMPONENTS IN LIFE SUPPORT DEVICES OR SYSTEMS WITHOUT THE EXPRESS WRITTEN APPROVAL OF FAIRCHILD SEMICONDUCTOR CORPORATION.

As used herein:

- Life support devices or systems are devices or systems which, (a) are intended for surgical implant into the body or (b) support or sustain life, and (c) whose failure to perform when properly used in accordance with instructions for use provided in the labeling, can be reasonably expected to result in a significant injury to the user.
- A critical component in any component of a life support, device or system whose failure to perform can be reasonably expected to cause the failure of the life support device or system, or to affect its safety or effectiveness.

**PRODUCT STATUS DEFINITIONS**

**Definition of Terms**

Datasheet Identification	Product Status	Definition
Advance Information	Formative or In Design	This datasheet contains the design specifications for product development. Specifications may change in any manner without notice.
Preliminary	First Production	This datasheet contains preliminary data; supplementary data will be published at a later date. Fairchild Semiconductor reserves the right to make changes at any time without notice to improve design.
No Identification Needed	Full Production	This datasheet contains final specifications. Fairchild Semiconductor reserves the right to make changes at any time without notice to improve design.
Obsolete	Not In Production	This datasheet contains specifications on a product that has been discontinued by Fairchild Semiconductor. The datasheet is printed for reference information only.

Rev. I33