

SANYO Semiconductors
DATA SHEET

An ON Semiconductor Company

LC87F2J32A

CMOS IC
FROM 32K byte, RAM 1024 byte on-chip
8-bit 1-chip Microcontroller

Overview

The SANYO LC87F2J32A is an 8-bit microcomputer that, centered around a CPU running at a minimum bus cycle time of 83.3ns, integrates on a single chip a number of hardware features such as 32K-byte flash ROM (On-board-programmable), 1024-byte RAM, an On-chip-debugger, sophisticated 16-bit timers/counters (may be divided into 8-bit timers), a 16-bit timer/counter (may be divided into 8-bit timers/counters or 8-bit PWMs), four 8-bit timers with a prescaler, a base timer serving as a time-of-day clock, a high-speed clock counter, a synchronous SIO interface, an asynchronous/synchronous SIO interface, a UART interface (full duplex), two 12-bit PWM channels, a 12/8-bit 14-channel AD converter, a system clock frequency divider, remote control receive, an internal reset and a 24-source 10-vector interrupt feature.

Features

■Flash ROM

- Capable of on-board-programming with wide range (2.2 to 5.5V) of voltage source.
- Block-erasable in 128-byte units
- Writable in 2-byte units
- 32768×8 bits

■RAM

- 1024×9 bits

■Minimum Bus Cycle

- 83.3ns (12MHz) $V_{DD}=2.7$ to 5.5V
- 100ns (10MHz) $V_{DD}=2.2$ to 5.5V
- 250ns (4MHz) $V_{DD}=1.8$ to 5.5V

Note: The bus cycle time here refers to the ROM read speed.

* This product is licensed from Silicon Storage Technology, Inc. (USA), and manufactured and sold by SANYO Semiconductor Co., Ltd.

■ Any and all SANYO Semiconductor Co.,Ltd. products described or contained herein are, with regard to "standard application", intended for the use as general electronics equipment (home appliances, AV equipment, communication device, office equipment, industrial equipment etc.). The products mentioned herein shall not be intended for use for any "special application" (medical equipment whose purpose is to sustain life, aerospace instrument, nuclear control device, burning appliances, transportation machine, traffic signal system, safety equipment etc.) that shall require extremely high level of reliability and can directly threaten human lives in case of failure or malfunction of the product or may cause harm to human bodies, nor shall they grant any guarantee thereof. If you should intend to use our products for applications outside the standard applications of our customer who is considering such use and/or outside the scope of our intended standard applications, please consult with us prior to the intended use. If there is no consultation or inquiry before the intended use, our customer shall be solely responsible for the use.

■ Specifications of any and all SANYO Semiconductor Co.,Ltd. products described or contained herein stipulate the performance, characteristics, and functions of the described products in the independent state, and are not guarantees of the performance, characteristics, and functions of the described products as mounted in the customer's products or equipment. To verify symptoms and states that cannot be evaluated in an independent device, the customer should always evaluate and test devices mounted in the customer's products or equipment.

SANYO Semiconductor Co., Ltd.
www.semiconductor-sanyo.com/network

LC87F2J32A

■ Minimum Instruction Cycle Time

- 250ns (12MHz) $V_{DD}=2.7$ to 5.5V
- 300ns (10MHz) $V_{DD}=2.2$ to 5.5V
- 750ns (4MHz) $V_{DD}=1.8$ to 5.5V

■ Ports

- Normal withstand voltage I/O ports
Ports I/O direction can be designated in 1-bit units 39 (P0n, P1n, P2n, P30 to P36, P70 to P73, PWM0, PWM1, XT2, CF2)
- Dedicated oscillator ports/input ports 2 (CF1, XT1)
- Reset pin 1 (RES)
- Power pins 6 (V_{SS1} to 3, V_{DD1} to 3)

■ Timers

- Timer 0: 16-bit timer/counter with a capture register.
Mode 0: 8-bit timer with an 8-bit programmable prescaler (with an 8-bit capture register) × 2 channels
Mode 1: 8-bit timer with an 8-bit programmable prescaler (with an 8-bit capture register) + 8-bit counter (with an 8-bit capture register)
Mode 2: 16-bit timer with an 8-bit programmable prescaler (with a 16-bit capture register)
Mode 3: 16-bit counter (with a 16-bit capture register)
- Timer 1: 16-bit timer/counter that supports PWM/toggle outputs
Mode 0: 8-bit timer with an 8-bit prescaler (with toggle outputs) + 8-bit timer/counter with an 8-bit prescaler (with toggle outputs)
Mode 1: 8-bit PWM with an 8-bit prescaler × 2 channels
Mode 2: 16-bit timer/counter with an 8-bit prescaler (with toggle outputs) (toggle outputs also possible from the lower-order 8 bits)
Mode 3: 16-bit timer with an 8-bit prescaler (with toggle outputs) (The lower-order 8 bits can be used as PWM.)
- Timer 4: 8-bit timer with a 6-bit prescaler
- Timer 5: 8-bit timer with a 6-bit prescaler
- Timer 6: 8-bit timer with a 6-bit prescaler (with toggle output)
- Timer 7: 8-bit timer with a 6-bit prescaler (with toggle output)
- Base timer
 - 1) The clock is selectable from the subclock (32.768kHz crystal oscillation), system clock, and timer 0 prescaler output.
 - 2) Interrupts are programmable in 5 different time schemes

■ High-speed Clock Counter

- 1) Can count clocks with a maximum clock rate of 20MHz (at a main clock of 10MHz)
- 2) Can generate output real-time

■ SIO

- SIO0: 8-bit synchronous serial interface
 - 1) LSB first/MSB first mode selectable
 - 2) Built-in 8-bit baudrate generator (maximum transfer clock cycle=4/3 tCYC)
 - 3) Automatic continuous data transmission (1 to 256 bits, specifiable in 1-bit units, suspension and resumption of data transmission possible in 1-byte units)
- SIO1: 8-bit asynchronous/synchronous serial interface
Mode 0: Synchronous 8-bit serial I/O (2- or 3-wire configuration, 2 to 512 tCYC transfer clocks)
Mode 1: Asynchronous serial I/O (half-duplex, 8-data bits, 1-stop bit, 8 to 2048 tCYC baudrates)
Mode 2: Bus mode 1 (start bit, 8-data bits, 2 to 512 tCYC transfer clocks)
Mode 3: Bus mode 2 (start detect, 8-data bits, stop detect)

■ UART

- Full duplex
- 7/8/9 bit data bits selectable
- 1 stop bit (2-bit in continuous data transmission)
- Built-in baudrate generator

LC87F2J32A

- AD Converter: 12 bits/8 bits × 14 channels
 - 12/8 bits AD converter resolution selectable

- PWM: Multifrequency 12-bit PWM × 2 channels

- Remote Control Receiver Circuit (sharing pins with P73, INT3, and T0IN)
 - 1) Noise rejection function
(Units of noise rejection filter : about 120μs, when selecting a 32.768kHz crystal oscillator as a clock.)
 - 2) Supporting reception formats with a guide-pulse of halt-clock/clock/none.
 - 3) Determines a end of reception by detecting a no-signal periods (No carrier).
(Supports same reception format with a different bit length.)
 - 4) X'tal HOLD mode release function

- Clock Output Function
 - Can generate clock outputs with a frequency of 1/1, 1/2, 1/4, 1/8, 1/16, 1/32, 1/64 of the source clock selected as the system clock.
 - Can generate the source clock for the subclock.

- Watchdog timer
 - External RC watchdog timer
 - Interrupt and reset signals selectable

- Interrupts
 - 24 sources, 10 vector addresses
 - 1) Provides three levels (low (L), high (H), and highest (X)) of multiplex interrupt control. Any interrupt requests of the level equal to or lower than the current interrupt are not accepted.
 - 2) When interrupt requests to two or more vector addresses occur at the same time, the interrupt of the highest level takes precedence over the other interrupts. For interrupts of the same level, the interrupt into the smallest vector address takes precedence.

No.	Vector Address	Level	Interrupt Source
1	00003H	X or L	INT0
2	0000BH	X or L	INT1
3	00013H	H or L	INT2/T0L/INT4/REMOREC2
4	0001BH	H or L	INT3/INT5/ BT0/BT1
5	00023H	H or L	T0H
6	0002BH	H or L	T1L/T1H
7	00033H	H or L	SIO0/UART1 receive
8	0003BH	H or L	SIO1/UART1 transmit
9	00043H	H or L	ADC/T6/T7
10	0004BH	H or L	Port 0/T4/T5/PWM0, PWM1

- Priority levels X > H > L
- Of interrupts of the same level, the one with the smallest vector address takes precedence.

- IFLG (List of interrupt source flag function)
 - 1) Shows a list of interrupt source flags that caused a branching to a particular vector address (shown in the table above).

- Subroutine Stack Levels: 512 levels (the stack is allocated in RAM)

- High-speed Multiplication/Division Instructions
 - 16 bits × 8 bits (5 tCYC execution time)
 - 24 bits × 16 bits (12 tCYC execution time)
 - 16 bits ÷ 8 bits (8 tCYC execution time)
 - 24 bits ÷ 16 bits (12 tCYC execution time)

■ Oscillation Circuits

- Internal oscillation circuits
 - 1) Low-speed RC oscillation circuit : For system clock(100kHz)
 - 2) Medium-speed RC oscillation circuit : For system clock(1MHz)
 - 3) Frequency variable RC oscillation circuit: For system clock(8MHz)
 - (1) Adjustable in 0.5% (typ) step from a selected center frequency.
 - (2) Measures oscillation clock using a input signal from XT1 as a reference.
- External oscillation circuits
 - 1) Low speed crystal oscillation circuit: For low-speed system clock, with internal Rf
 - 2) Hi-speed CF oscillation circuit: For system clock, with internal Rf
 - (1) Both the CF and crystal oscillator circuits stop operation on a system reset.

■ System Clock Divider Function

- Can run on low current.
- The minimum instruction cycle selectable from 300ns, 600ns, 1.2μs, 2.4μs, 4.8μs, 9.6μs, 19.2μs, 38.4μs, and 76.8μs (at a main clock rate of 10MHz).

■ Internal Reset Function

- Power-on reset (POR) function
 - 1) POR reset is generated only at power-on time.
 - 2) The POR release level can be selected from 8 levels (1.67V, 1.97V, 2.07V, 2.37V, 2.57V, 2.87V, 3.86V, and 4.35V) through option configuration.
- Low-voltage detection reset (LVD) function
 - 1) LVD and POR functions are combined to generate resets when power is turned on and when power voltage falls below a certain level.
 - 2) The use/disuse of the LVD function and the low voltage threshold level (7 levels: 1.91V, 2.01V, 2.31V, 2.51V, 2.81V, 3.79V, 4.28V).

■ Standby Function

- HALT mode: Halts instruction execution while allowing the peripheral circuits to continue operation.
 - 1) Oscillation is not halted automatically.
 - 2) There are three ways of resetting the HALT mode.
 - (1) Setting the reset pin to the low level
 - (2) System resetting by watchdog timer or low-voltage detection
 - (3) Occurrence of an interrupt
- HOLD mode: Suspends instruction execution and the operation of the peripheral circuits.
 - 1) The CF, RC, and crystal oscillators automatically stop operation.
 - 2) There are four ways of resetting the HOLD mode.
 - (1) Setting the reset pin to the low level.
 - (2) System resetting by watchdog timer or low-voltage detection
 - (3) Having an interrupt source established at either INT0, INT1, INT2, INT4, or INT5
 - * INT0 and INT1 HOLD mode reset is available only when level detection is set.
 - (4) Having an interrupt source established at port 0
- X'tal HOLD mode: Suspends instruction execution and the operation of the peripheral circuits except the base timer.
 - 1) The CF and RC oscillators automatically stop operation.
 - 2) The state of crystal oscillation established when the X'tal HOLD mode is entered is retained.
 - 3) There are six ways of resetting the X'tal HOLD mode.
 - (1) Setting the reset pin to the low level
 - (2) System resetting by watchdog timer or low-voltage detection
 - (3) Having an interrupt source established at either INT0, INT1, INT2, INT4, or INT5
 - * INT0 and INT1 HOLD mode reset is available only when level detection is set.
 - (4) Having an interrupt source established at port 0
 - (5) Having an interrupt source established in the base timer circuit
 - (6) Having an interrupt source established in the infrared remote controller receiver circuit

LC87F2J32A

■ On-chip Debugger

- Supports software debugging with the IC mounted on the target board (LC87D2J32A).
LC87F2J32A has an On-chip debugger but its function is limited.

■ Data Security Function (flash versions only)

- Protects the program data stored in flash memory from unauthorized read or copy.
Note: This data security function does not necessarily provide absolute data security.

■ Package Form

- SQFP48 (7×7): Lead-/Halogen-free type
- QIP48E (14×14): Lead-free type
- FLGA49 (5×5): Lead-free type (This package is Built To Order.)

■ Development Tools

- On-chip debugger: TCB87- TypeB + LC87D2J32A

■ Programming Board

Package	Programming boards
SQFP48 (7×7)	W87F55256SQ
QIP48E (14×14)	W87F55256Q

■ Flash ROM Programmer

Maker		Model	Supported version	Device
Flash Support Group, Inc. (FSG)	Single programmer	AF9708 AF9709/AF9709B/AF9709C (Including Ando Electric Co., Ltd. models)	Rev 03.07 or later	LC87F2J32A
	Gang programmer	AF9723/AF9723B(Main body) (Including Ando Electric Co., Ltd. models)	-	-
		AF9833(Unit) (Including Ando Electric Co., Ltd. models)	-	
Flash Support Group, Inc. (FSG) + Sanyo (Note 1)	In-circuit programmer	AF9101/AF9103(Main body) (FSG models)	(Note 2)	LC87F2J32A
		SIB87(Inter Face Driver) (SANYO model)		
SANYO	Single/Gang programmer	SKK/SKK Type B (SANYO FWS)	Application Version 1.04 or later Chip Data Version 2.16 or later	LC87F2J32A
	In-circuit/ Gang programmer	SKK-DBG Type B (SANYO FWS)		

Note1: On-board-programmer from FSG (AF9101/AF9103) and serial interface driver from SANYO (SIB87) together can give a PC-less, standalone on-board-programming capabilities.

Note2: It needs a special programming devices and applications depending on the use of programming environment.
Please ask FSG or SANYO for the information.

Package Dimensions

unit : mm (typ)

3163B

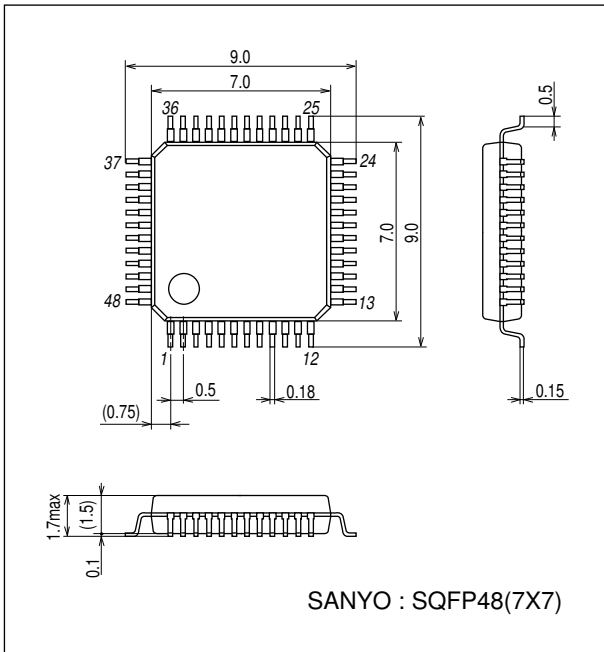

Package Dimensions

unit : mm (typ)

3156A

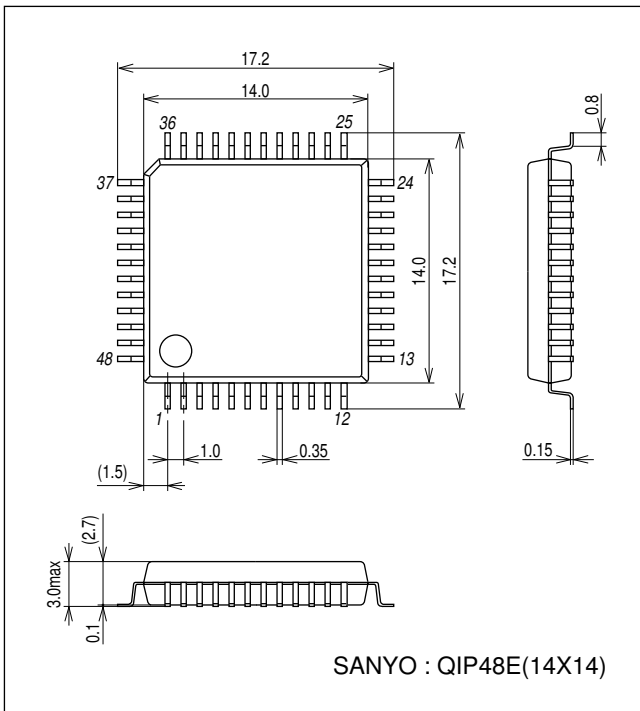

LC87F2J32A

Pin Assignment

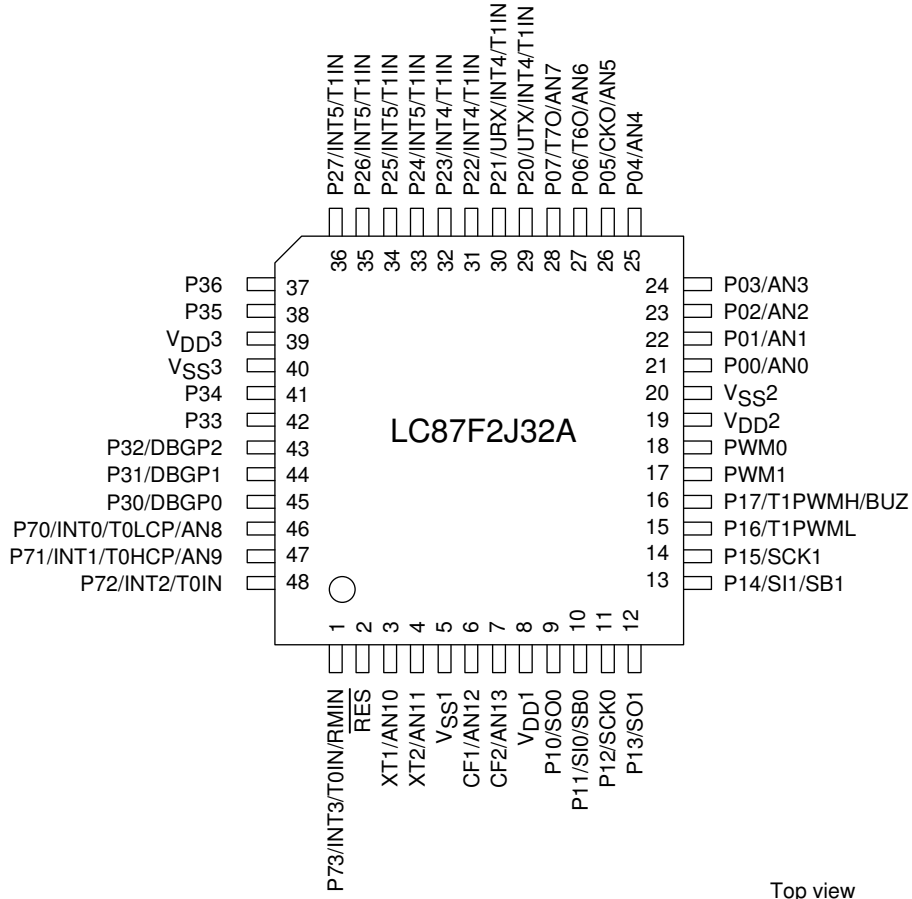

Top view

SANYO: SQFP48 (7×7) “Lead- / Halogen-free Type”
 SANYO: QIP48E (14×14) “Lead-free Type”

SQFP/QIP	NAME	SQFP/QIP	NAME	SQFP/QIP	NAME
1	P73/INT3/T0IN/RMIN	17	PWM1	33	P24/INT5/T1IN
2	RES	18	PWM0	34	P25/INT5/T1IN
3	XT1/AN10	19	VDD2	35	P26/INT5/T1IN
4	XT2/AN11	20	VSS2	36	P27/INT5/T1IN
5	VSS1	21	P00/AN0	37	P36
6	CF1/AN12	22	P01/AN1	38	P35
7	CF2/AN13	23	P02/AN2	39	VDD3
8	VDD1	24	P03/AN3	40	VSS3
9	P10/SO0	25	P04/AN4	41	P34
10	P11/SI0/SB0	26	P05/CKO/AN5	42	P33
11	P12/SCK0	27	P06/T6O/AN6	43	P32/DBGP2
12	P13/SO1	28	P07/T7O/AN7	44	P31/DBGP1
13	P14/SI1/SB1	29	P20/UTX/INT4/T1IN	45	P30/DBGP0
14	P15/SCK1	30	P21/URX/INT4/T1IN	46	P70/INT0/T0LCP/AN8
15	P16/T1PWML	31	P22/INT4/T1IN	47	P71/INT1/T0HCP/AN9
16	P17/T1PWMH/BUZ	32	P23/INT4/T1IN	48	P72/INT2/T0IN

System Block Diagram

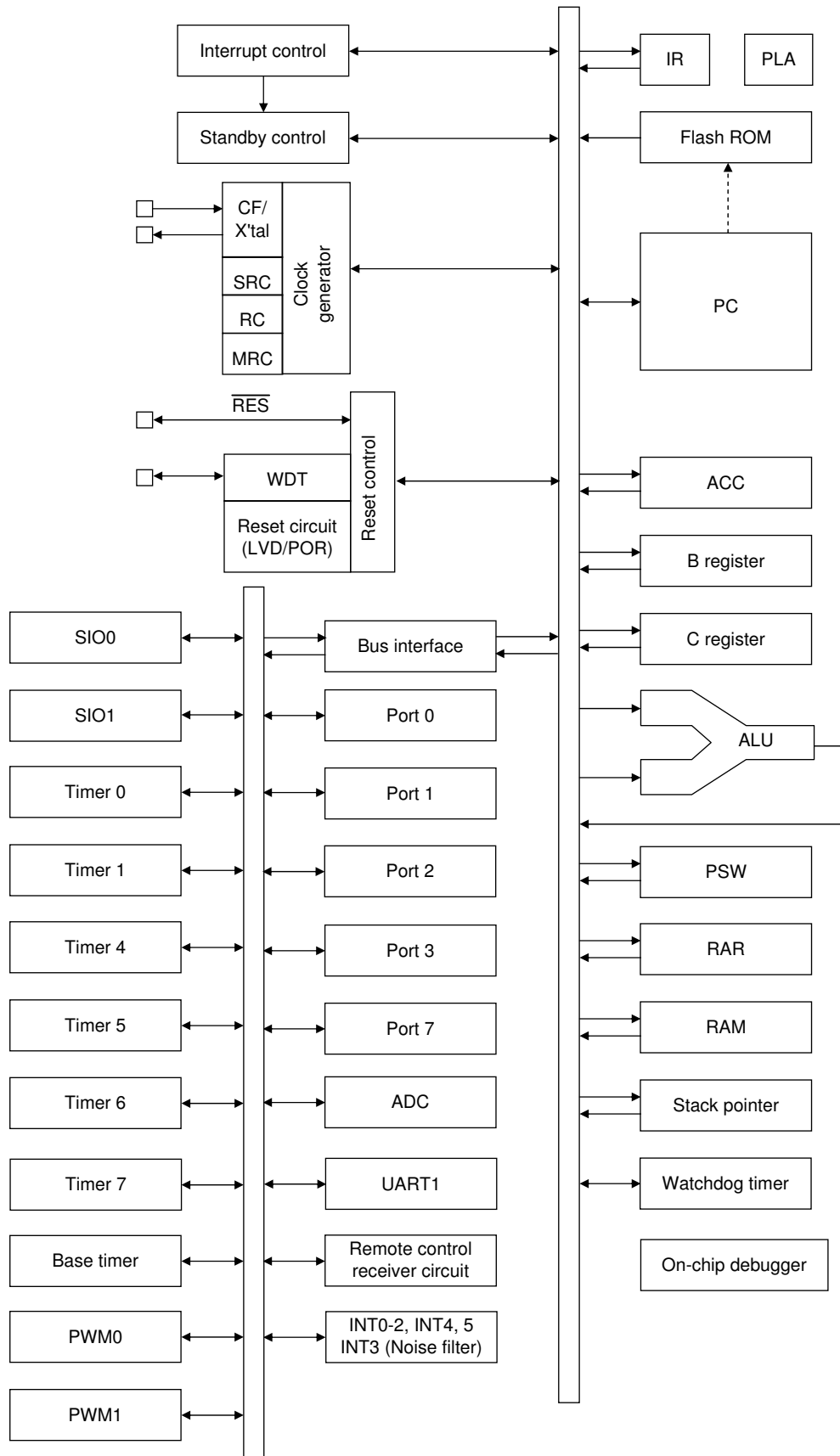

LC87F2J32A

Pin Description

Pin Name	I/O	Description	Option																		
V _{SS} 1 to V _{SS} 3	-	- power supply pins	No																		
V _{DD} 1 to V _{DD} 3	-	+ power supply pin	No																		
Port 0 P00 to P07	I/O	<ul style="list-style-type: none"> • 8-bit I/O port • I/O specifiable in 1-bit units • Pull-up resistors can be turned on and off in 1-bit units. • HOLD reset input • Port 0 interrupt input • Pin functions <ul style="list-style-type: none"> P05: System clock output P06: Timer 6 toggle output P07: Timer 7 toggle output P00(AN0) to P07(AN7): AD converter input 	Yes																		
Port 1 P10 to P17	I/O	<ul style="list-style-type: none"> • 8-bit I/O port • I/O specifiable in 1-bit units • Pull-up resistors can be turned on and off in 1-bit units. • Pin functions <ul style="list-style-type: none"> P10: SIO0 data output P11: SIO0 data input/bus I/O P12: SIO0 clock I/O P13: SIO1 data output P14: SIO1 data input / bus I/O P15: SIO1 clock I/O P16: Timer 1PWML output P17: Timer 1PWMLH output/beeper output 	Yes																		
Port 2 P20 to P27	I/O	<ul style="list-style-type: none"> • 8-bit I/O port • I/O specifiable in 1-bit units • Pull-up resistors can be turned on and off in 1-bit units. • Pin functions <ul style="list-style-type: none"> P20: UART transmit P21: UART receive P20 to P23: INT4 input/HOLD reset input/timer 1 event input/timer 0L capture input/timer 0H capture input P24 to P27: INT5 input/HOLD reset input/timer 1 event input/timer 0L capture input/timer 0H capture input Interrupt acknowledge type <table border="1" style="margin-left: 20px; width: 100%; border-collapse: collapse; text-align: center;"> <thead> <tr> <th></th> <th>Rising</th> <th>Falling</th> <th>Rising & Falling</th> <th>H level</th> <th>L level</th> </tr> </thead> <tbody> <tr> <td>INT4</td> <td>enable</td> <td>enable</td> <td>enable</td> <td>disable</td> <td>disable</td> </tr> <tr> <td>INT5</td> <td>enable</td> <td>enable</td> <td>enable</td> <td>disable</td> <td>disable</td> </tr> </tbody> </table> 		Rising	Falling	Rising & Falling	H level	L level	INT4	enable	enable	enable	disable	disable	INT5	enable	enable	enable	disable	disable	Yes
	Rising	Falling	Rising & Falling	H level	L level																
INT4	enable	enable	enable	disable	disable																
INT5	enable	enable	enable	disable	disable																
Port 3 P30 to P36	I/O	<ul style="list-style-type: none"> • 7-bit I/O port • I/O specifiable in 1-bit units • Pull-up resistors can be turned on and off in 1-bit units. • Shared pins <ul style="list-style-type: none"> On-chip debugger pins: DBG P0 to DBG P2 (P30 to P32) 	Yes																		

Continued on next page.

LC87F2J32A

Continued from preceding page.

Pin Name	I/O	Description	Option																														
Port 7 P70 to P73	I/O	<ul style="list-style-type: none"> • 4-bit I/O port • I/O specifiable in 1-bit units • Pull-up resistors can be turned on and off in 1-bit units. • Pin functions P70: INT0 input/HOLD reset input/timer 0L capture input/watchdog timer output P71: INT1 input/HOLD reset input/timer 0H capture input P72: INT2 input HOLD reset input/timer 0 event input/timer 0L capture input P73: INT3 input (with noise filter)/timer 0 event input/timer 0H capture input P70(AN8), P71(AN9) : AD converter input Interrupt acknowledge type <table border="1" style="margin-left: 20px;"> <thead> <tr> <th></th> <th>Rising</th> <th>Falling</th> <th>Rising & Falling</th> <th>H level</th> <th>L level</th> </tr> </thead> <tbody> <tr> <td>INT0</td> <td>enable</td> <td>enable</td> <td>disable</td> <td>enable</td> <td>enable</td> </tr> <tr> <td>INT1</td> <td>enable</td> <td>enable</td> <td>disable</td> <td>enable</td> <td>enable</td> </tr> <tr> <td>INT2</td> <td>enable</td> <td>enable</td> <td>enable</td> <td>disable</td> <td>disable</td> </tr> <tr> <td>INT3</td> <td>enable</td> <td>enable</td> <td>enable</td> <td>disable</td> <td>disable</td> </tr> </tbody> </table>		Rising	Falling	Rising & Falling	H level	L level	INT0	enable	enable	disable	enable	enable	INT1	enable	enable	disable	enable	enable	INT2	enable	enable	enable	disable	disable	INT3	enable	enable	enable	disable	disable	No
	Rising	Falling	Rising & Falling	H level	L level																												
INT0	enable	enable	disable	enable	enable																												
INT1	enable	enable	disable	enable	enable																												
INT2	enable	enable	enable	disable	disable																												
INT3	enable	enable	enable	disable	disable																												
PWM0, PWM1	I/O	<ul style="list-style-type: none"> • PWM0 and PWM1 output ports • General-purpose I/O available 	No																														
RES	I/O	External reset Input/internal reset output	No																														
XT1	Input	<ul style="list-style-type: none"> • 32.768kHz crystal oscillator input pin • Shared pins General-purpose input port AD converter input port: AN10	No																														
XT2	I/O	<ul style="list-style-type: none"> • 32.768kHz crystal oscillator output pin • Shared pins General-purpose I/O port AD converter input port: AN11	No																														
CF1	Input	Ceramic resonator input pin <ul style="list-style-type: none"> • Shared pins General-purpose input port AD converter input port: AN12	No																														
CF2	Output	Ceramic resonator output pin <ul style="list-style-type: none"> • Shared pins General-purpose I/O port AD converter input port: AN13	No																														

On-chip Debugger Pin Connection Requirements

For the treatment of the on-chip debugger pins, refer to the separately available documents entitled “RD87 On-chip Debugger Installation Manual”

Recommended Unused Pin Connections

Port Name	Recommended Unused Pin Connections	
	Board	Software
P00 to P07	Open	Output low
P10 to P17	Open	Output low
P20 to P21	Open	Output low
P30 to P36	Open	Output low
P70 to P73	Open	Output low
PWM0,PWM1	Open	Output low
XT1	Pulled low with a 100kΩ resistor or less	General-purpose input port
XT2	Open	Output low
CF1	Pulled low with a 100kΩ resistor or less	General-purpose input port
CF2	Open	Output low

LC87F2J32A

Port Output Types

The table below lists the types of port outputs and the presence/absence of a pull-up resistor. Data can be read into any input port even if it is in the output mode.

Port Name	Option Selected in Units of	Option Type	Output Type	Pull-up Resistor
P00 to P07	1 bit	1	CMOS	Programmable (Note 1)
		2	Nch-open drain	Programmable (Note 1)
P10 to P17	1 bit	1	CMOS	Programmable
		2	Nch-open drain	Programmable
P20 to P27	1 bit	1	CMOS	Programmable
		2	Nch-open drain	Programmable
P30 to P36	1 bit	1	CMOS	Programmable
		2	Nch-open drain	Programmable
P70	-	No	Nch-open drain	Programmable
P71 to P73	-	No	CMOS	Programmable
PWM0, PWM1	-	No	CMOS	No
XT1	-	No	Input for 32.768kHz crystal oscillator (Input only)	No
XT2	-	No	Output for 32.768kHz crystal oscillator (Nch-open drain when in general-purpose output mode)	No
CF1	-	No	Input for ceramic resonator oscillator (Input only)	No
CF2	-	No	Output for ceramic resonator oscillator (Nch-open drain when in general-purpose output mode)	No

Note 1: The control of the presence or absence of the programmable pull-up resistors for port 0 and the switching between low- and high-impedance pull-up connection is exercised in 1-bit units.

LC87F2J32A

User Option Table

Option name	Option to be applied on	Flash-ROM version	Option selected in units of	Option selection
Port output type	P00 to P07	○	1 bit	CMOS
				Nch-open drain
	P10 to P17	○	1 bit	CMOS
				Nch-open drain
	P20 to P27	○	1 bit	CMOS
				Nch-open drain
	P30 to P36	○	1 bit	CMOS
				Nch-open drain
Program start address	-	○	-	0000h
				07E0h
Low-voltage detection reset function	Detect function	○	-	Enable: Use
				Disable: Not Used
Power-on reset function	Power-On reset level	○	-	7-level
				8-level

Note: To reduce V_{DD} signal noise and to increase the duration of the backup battery supply, V_{SS1} , V_{SS2} , and V_{SS3} should connect to each other and they should also be grounded.

Example 1: During backup in hold mode, port output 'H' level is supplied from the back-up capacitor.

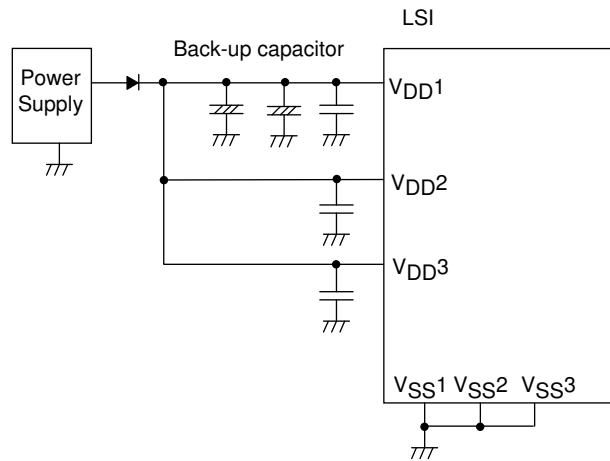

Example 2: During backup in hold mode, output is not held high and its value is unsettled.

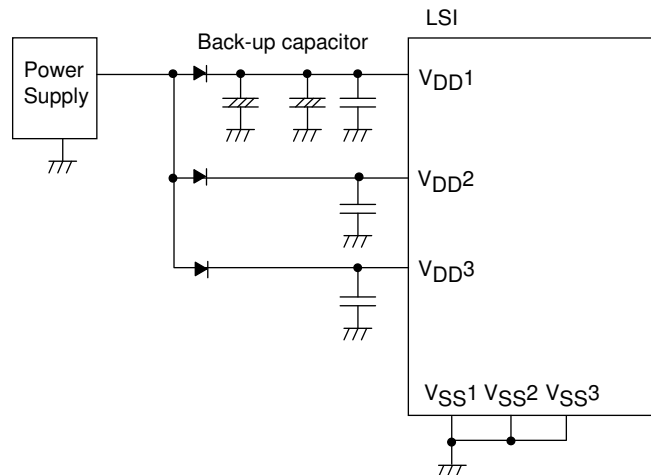

LC87F2J32A

Absolute Maximum Ratings at Ta = 25°C, VSS1 = VSS2 = VSS3 = 0V

Parameter	Symbol	Pin/Remarks	Conditions	Specification				unit	
				VDD[V]	min	typ	max		
Maximum supply voltage	VDD max	VDD1, VDD2, VDD3	VDD1=VDD2=VDD3		-0.3		+6.5	V	
Input voltage	VI	XT1, CF1			-0.3		VDD+0.3		
Input/output voltage	VI/O	Ports 0, 1, 2, 3, Port 7, PWM0, PWM1, XT2, CF2			-0.3		VDD+0.3		
High level output current	Peak output current	IOPH(1)	Ports 0, 1, 2, 3	CMOS output select Per 1 applicable pin		-10		mA	
		IOPH(2)	PWM0, PWM1			-20			
		IOPH(3)	P71 to P73	Per 1 applicable pin		-5			
	Mean output current (Note 1-1)	IOMH(1)	Ports 0, 1, 2, 3	CMOS output select Per 1 applicable pin		-7.5			
		IOMH(2)	PWM0, PWM1			-15			
		IOMH(3)	P71 to P73	Per 1 applicable pin		-3			
	Total output current	ΣIOAH(1)	P71 to P73	Total of all applicable pins		-10			
		ΣIOAH(2)	Port 0	Total of all applicable pins		-25			
		ΣIOAH(3)	Port 1, PWM0, PWM1	Total of all applicable pins		-25			
		ΣIOAH(4)	Ports 0, 1, PWM0, PWM1	Total of all applicable pins		-45			
		ΣIOAH(5)	Ports 2, P35, P36	Total of all applicable pins		-25			
		ΣIOAH(6)	P30 to P34	Total of all applicable pins		-25			
		ΣIOAH(7)	Ports 2, 3	Total of all applicable pins		-45			
Low level output current	Peak output current	IOPL(1)	P02 to P07, Ports 1, 2, 3, PWM0, PWM1	Per 1 applicable pin			20		
		IOPL(2)	P00, P01	Per 1 applicable pin			30		
		IOPL(3)	Port 7, XT2, CF2	Per 1 applicable pin			10		
	Mean output current (Note 1-1)	IOML(1)	P02 to P07, Ports 1, 2, 3, PWM0, PWM1	Per 1 applicable pin				15	
		IOML(2)	P00, P01	Per 1 applicable pin				20	
		IOML(3)	Port 7, XT2, CF2	Per 1 applicable pin				7.5	
	Total output current	ΣIOAL(1)	Port 7, XT2, CF2	Total of all applicable pins				15	
		ΣIOAL(2)	Port 0	Total of all applicable pins				45	
		ΣIOAL(3)	Port 1, PWM0, PWM1	Total of all applicable pins				45	
		ΣIOAL(4)	Port 0, 1, PWM0, PWM1	Total of all applicable pins				80	
ΣIOAL(5)		Ports 2, P35, P36	Total of all applicable pins				45		
ΣIOAL(6)		P30 to P34	Total of all applicable pins				45		
ΣIOAL(7)		Ports 2, 3	Total of all applicable pins				60		
Power dissipation	Pd max(1)	SQFP48 (7×7)	Ta=-40 to +85°C Package only				139	mW	
	Pd max(2)		Ta=-40 to +85°C Package with thermal resistance board (Note 1-2)				356		
	Pd max(3)	QIP48E (14×14)	Ta=-40 to +85°C Package only				281		
	Pd max(4)		Ta=-40 to +85°C Package with thermal resistance board (Note 1-2)				489		
Operating ambient temperature	Topr				-40		+85	°C	
Storage ambient temperature	Tstg				-55		+125		

Note 1-1: The mean output current is a mean value measured over 100ms.

Note 1-2: SEMI standards thermal resistance board (size: 76.1×114.3×1.6mm, glass epoxy) is used.

LC87F2J32A

Allowable Operating Conditions at Ta = -40°C to +85°C, V_{SS1} = V_{SS2} = V_{SS3} = 0V

Parameter	Symbol	Pin/Remarks	Conditions	Specification				unit
				V _{DD} [V]	min	typ	max	
Operating supply voltage (Note 2-1)	V _{DD} (1)	V _{DD1} =V _{DD2} =V _{DD3}	0.245μs≤tCYC≤200μs		2.7		5.5	V
	V _{DD} (2)				2.2		5.5	
	V _{DD} (3)				1.8		5.5	
Memory sustaining supply voltage	V _H D	V _{DD1} =V _{DD2} =V _{DD3}	RAM and register contents sustained in HOLD mode.		1.6		5.5	
High level input voltage	V _I H(1)	Ports 1, 2, 3, P71 to P73 P70 port input/ interrupt side PWM0, PWM1		1.8 to 5.5	0.3V _{DD} +0.7		V _{DD}	V
	V _I H(2)	Port 0		1.8 to 5.5	0.3V _{DD} +0.7		V _{DD}	
	V _I H(3)	Port 70 watchdog timer side		1.8 to 5.5	0.9V _{DD}		V _{DD}	
	V _I H(4)	XT1, XT2, CF1, CF2, RES		1.8 to 5.5	0.75V _{DD}		V _{DD}	
Low level input voltage	V _I L(1)	Ports 1, 2, 3, P71 to P73 P70 port input/ interrupt side PWM0, PWM1		4.0 to 5.5	V _{SS}		0.1V _{DD} +0.4	μs
				1.8 to 4.0	V _{SS}		0.2V _{DD}	
	V _I L(2)	Port 0		4.0 to 5.5	V _{SS}		0.15V _{DD} +0.4	
				1.8 to 4.0	V _{SS}		0.2V _{DD}	
	V _I L(3)	Port 70 watchdog timer side		1.8 to 5.5	V _{SS}		0.8V _{DD} -1.0	
	V _I L(4)	XT1, XT2, CF1, CF2, RES		1.8 to 5.5	V _{SS}		0.25V _{DD}	
Instruction cycle time (Note 2-1)	tCYC (Note 2-2)			2.7 to 5.5	0.245		200	μs
				2.2 to 5.5	0.294		200	
				1.8 to 5.5	0.735		200	
External system clock frequency	FEXCF	CF1	<ul style="list-style-type: none"> • CF2 pin open • System clock frequency division ratio=1/1 • External system clock duty= 50±5% 	2.7 to 5.5	0.1		12	MHz
				1.8 to 5.5	0.1		4	
				3.0 to 5.5	0.2		24.4	
				2.0 to 5.5	0.2		8	
Oscillation frequency range (Note 2-3)	FmCF(1)	CF1, CF2	12MHz ceramic oscillation See Fig. 1.	2.7 to 5.5		12		MHz
	FmCF(2)	CF1, CF2	10MHz ceramic oscillation See Fig. 1.	2.2 to 5.5		10		
	FmCF(3)	CF1, CF2	4MHz ceramic oscillation. CF oscillation normal amplifier size selected. See Fig. 1. (CFLAMP=0)	1.8 to 5.5		4		
			4MHz ceramic oscillation. CF oscillation low amplifier size selected. (CFLAMP=1) See Fig. 1.	2.2 to 5.5		4		

Note 2-1: V_{DD} must be held greater than or equal to 2.2V in the flash ROM onboard programming mode.

Note 2-2: Relationship between tCYC and oscillation frequency is 3/FmCF at a division ratio of 1/1 and 6/FmCF at a division ratio of 1/2.

Continued on next page.

LC87F2J32A

Continued from preceding page.

Parameter	Symbol	Pin/Remarks	Conditions	Specification				unit
				V _{DD} [V]	min	typ	max	
Oscillation frequency range (Note 2-3)	FmMRC(1)		Frequency variable RC oscillation. 1/2 frequency division ratio. (RCCTD=0) (Note 2-4)	2.4 to 5.5	7.44	8.0	8.56	MHz
	FmMRC(2)		Frequency variable RC oscillation. 1/2 frequency division ratio. (RCCTD=0) Ta=-10 to +50°C (Note 2-4)	2.4 to 5.5	7.6	8.0	8.4	
	FmRC		Internal Medium-speed RC oscillation	1.8 to 5.5	0.5	1.0	2.0	
	FmSRC		Internal Low-speed RC oscillation	1.8 to 5.5	50	100	200	kHz
	FsX'tal	XT1, XT2	32.768kHz crystal oscillation See Fig. 3.	1.8 to 5.5		32.768		
Frequency variable RC oscillation usable range	OpVMRC		Frequency variable RC oscillation. 1/2 frequency division ratio. (RCCTD=0)	2.4 to 5.5	6	8	10	MHz
Frequency variable RC oscillation adjustment range	VmADJ(1)		Each step of VMRCHBn	2.4 to 5.5	3.6	7.0	11	%
	VmADJ(2)		Each step of VMFCHBn	2.4 to 5.5	0.7	1.5	2.3	
	VmADJ(3)		Each step of VMDCHn	2.4 to 5.5	0.2	0.5	1.1	

Note 2-3: See Tables 1 and 2 for the oscillation constants.

Note 2-4: When switching the system clock, allow an oscillation stabilization time of 100 μ s or longer after the multifrequency RC oscillator circuit transmits from the "oscillation stopped" to "oscillation enabled" state.

LC87F2J32A

Electrical Characteristics at Ta = -40°C to +85°C, VSS1 = VSS2 = VSS3 = 0V

Parameter	Symbol	Pin/Remarks	Conditions	VDD[V]	Specification			unit
					min	typ	max	
High level input current	I _{IH} (1)	Ports 0, 1, 2, 3 Ports 7 RES PWM0, PWM1	Output disabled Pull-up resistor off V _{IN} =V _{DD} (Including output Tr's off leakage current)	1.8 to 5.5			1	μA
	I _{IH} (2)	XT1, XT2, CF2	Input port selected V _{IN} =V _{DD}	1.8 to 5.5			1	
	I _{IH} (3)	CF1	V _{IN} =V _{DD}	1.8 to 5.5			15	
Low level input current	I _{IL} (1)	Ports 0, 1, 2, 3 Port 7 RES PWM0, PWM1	Output disabled Pull-up resistor off V _{IN} =V _{SS} (Including output Tr's off leakage current)	1.8 to 5.5	-1			μA
	I _{IL} (2)	XT1, XT2, CF2	Input port selected V _{IN} =V _{SS}	1.8 to 5.5	-1			
	I _{IL} (3)	CF1	V _{IN} =V _{SS}	1.8 to 5.5	-15			
High level output voltage	V _{OH} (1)	Ports 0, 1, 2, 3, P71 to P73	I _{OH} =-1mA	4.5 to 5.5	V _{DD} -1			V
	V _{OH} (2)		I _{OH} =-0.35mA	2.7 to 5.5	V _{DD} -0.4			
	V _{OH} (3)		I _{OH} =-0.15mA	1.8 to 5.5	V _{DD} -0.4			
	V _{OH} (4)	PWM0, PWM1, P05(System clock output function used)	I _{OH} =-6mA	4.5 to 5.5	V _{DD} -1			
	V _{OH} (5)		I _{OH} =-1.4mA	2.7 to 5.5	V _{DD} -0.4			
	V _{OH} (6)		I _{OH} =-0.8mA	1.8 to 5.5	V _{DD} -0.4			
Low level output voltage	V _{OL} (1)	Ports 0, 1, 2, 3, PWM0, PWM1,	I _{OL} =10mA	4.5 to 5.5			1.5	V
	V _{OL} (2)		I _{OL} =1.4mA	2.7 to 5.5			0.4	
	V _{OL} (3)		I _{OL} =0.8mA	1.8 to 5.5			0.4	
	V _{OL} (4)	P00, P01	I _{OL} =25mA	4.5 to 5.5			1.5	
	V _{OL} (5)		I _{OL} =4mA	2.7 to 5.5			0.4	
	V _{OL} (6)		I _{OL} =2mA	1.8 to 5.5			0.4	
	V _{OL} (7)	Port 7, XT2, CF2	I _{OL} =1.4mA	2.7 to 5.5			0.4	
	V _{OL} (8)		I _{OL} =0.8mA	1.8 to 5.5			0.4	
Pull-up resistance	R _{pu} (1)	Ports 0, 1, 2, 3	V _{OH} =0.9V _{DD} When Port 0 selected low-impedance pull-up.	4.5 to 5.5	15	35	80	kΩ
	R _{pu} (2)	Port 7		1.8 to 4.5	18	50	230	
	R _{pu} (3)	Port 0	V _{OH} =0.9V _{DD} When Port 0 selected High-impedance pull-up.	1.8 to 5.5	100	210	400	
Hysteresis voltage	V _{HYS} (1)	Ports 1, 2, 3, 7, RES, XT2		2.7 to 5.5		0.1 V _{DD}		V
	V _{HYS} (2)			1.8 to 2.7		0.07 V _{DD}		
Pin capacitance	CP	All pins	For pins other than that under test: V _{IN} =V _{SS} , f=1MHz, Ta=25°C	1.8 to 5.5		10		pF

LC87F2J32A

Serial Input/Output Characteristics at Ta = -40°C to +85°C, VSS1 = VSS2 = VSS3 = 0V

1. SIO0 Serial I/O Characteristics (Note 4-1-1)

Parameter		Symbol	Pin/Remarks	Conditions	VDD[V]	Specification				
						min	typ	max	unit	
Serial clock	Input clock	Frequency	tSCK(1)	SCK0(P12)	• See Fig. 6.	1.8 to 5.5	2			tCYC
		Low level pulse width	tSCKL(1)				1			
		High level pulse width	tSCKH(1)				1			
	Output clock	Frequency	tSCK(2)	SCK0(P12)	• CMOS output selected • See Fig. 6	1.8 to 5.5	4/3			tSCK
		Low level pulse width	tSCKL(2)				1/2			
		High level pulse width	tSCKH(2)				1/2			
Serial input	Data setup time	tsDI(1)	SB0(P11), SIO(P11)	• Must be specified with respect to rising edge of SIOCLK. • See Fig. 6.	1.8 to 5.5	0.05				
	Data hold time	thDI(1)				0.05				
Serial output	Input clock	Output delay time	tdD0(1)	SO0(P10), SB0(P11)	• Continuous data transmission/reception mode (Note 4-1-2) • Synchronous 8-bit mode (Note 4-1-2) (Note 4-1-2)	1.8 to 5.5			(1/3)tCYC +0.08	μs
			tdD0(2)						1tCYC +0.08	
			tdD0(3)						(1/3)tCYC +0.08	

Note 4-1-1: These specifications are theoretical values. Add margin depending on its use.

Note 4-1-2: Must be specified with respect to falling edge of SIOCLK. Must be specified as the time to the beginning of output state change in open drain output mode. See Fig. 6.

2. SIO1 Serial I/O Characteristics (Note 4-2-1)

Parameter		Symbol	Pin/Remarks	Conditions	VDD[V]	Specification				
						min	typ	max	unit	
Serial clock	Input clock	Frequency	tSCK(3)	SCK1(P15)	• See Fig. 6.	1.8 to 5.5	2			tCYC
		Low level pulse width	tSCKL(3)				1			
		High level pulse width	tSCKH(3)				1			
	Output clock	Frequency	tSCK(4)	SCK1(P15)	• CMOS output selected • See Fig. 6	1.8 to 5.5	2			tSCK
		Low level pulse width	tSCKL(4)				1/2			
		High level pulse width	tSCKH(4)				1/2			
Serial input	Data setup time	tsDI(2)	SB1(P14), SIO(P14)	• Must be specified with respect to rising edge of SIOCLK. • See Fig. 6.	1.8 to 5.5	0.05				
	Data hold time	thDI(2)				0.05				
Serial output	Output delay time	tdD0(4)	SO1(P13), SB1(P14)	• Must be specified with respect to falling edge of SIOCLK. • Must be specified as the time to the beginning of output state change in open drain output mode. • See Fig. 6.	1.8 to 5.5			(1/3)tCYC +0.08	μs	

Note 4-2-1: These specifications are theoretical values. Add margin depending on its use.

LC87F2J32A

Pulse Input Conditions at Ta = -40°C to +85°C, VSS1 = VSS2 = VSS3 = 0V

Parameter	Symbol	Pin/Remarks	Conditions	Specification				
				VDD[V]	min	typ	max	unit
High/low level pulse width	tPIH(1) tPIL(1)	INT0(P70), INT1(P71), INT2(P72), INT4(P20 to P23) INT5(P24 to P27)	<ul style="list-style-type: none"> Interrupt source flag can be set. Event inputs for timer 0 or 1 are enabled. 	1.8 to 5.5	1			tCYC
	tPIH(2) tPIL(2)	INT3(P73) when noise filter time constant is 1/1	<ul style="list-style-type: none"> Interrupt source flag can be set. Event inputs for timer 0 are enabled. 	1.8 to 5.5	2			
	tPIH(3) tPIL(3)	INT3(P73) when noise filter time constant is 1/32	<ul style="list-style-type: none"> Interrupt source flag can be set. Event inputs for timer 0 are enabled. 	1.8 to 5.5	64			
	tPIH(4) tPIL(4)	INT3(P73) when noise filter time constant is 1/128	<ul style="list-style-type: none"> Interrupt source flag can be set. Event inputs for timer 0 are enabled. 	1.8 to 5.5	256			
	tPIL(5)	$\overline{\text{RES}}$	<ul style="list-style-type: none"> Resetting is enabled. 	1.8 to 5.5	200			μs

AD Converter Characteristics at VSS1 = VSS2 = VSS3 = 0V

<12bits AD Converter Mode at Ta = -40 to +85°C>

Parameter	Symbol	Pin/Remarks	Conditions	Specification				
				VDD[V]	min	typ	max	unit
Resolution	N	AN0(P00) to AN7(P07)		2.4 to 5.5		12		bit
Absolute accuracy	ET	AN8(P70)	(Note 6-1)	3.0 to 5.5			±16	LSB
		AN9(P71)	(Note 6-1)	2.4 to 3.6			±20	
Conversion time	TCAD	AN10(XT1) AN11(XT2) AN12(CF1) AN13(CF2)	• See Conversion time calculation formulas. (Note 6-2)	4.0 to 5.5	32		115	μs
				3.0 to 5.5	64		115	
			• See Conversion time calculation formulas. (Note 6-2)	2.4 to 3.6	410		425	
Analog input voltage range	VAIN			2.4 to 5.5	VSS		VDD	V
Analog port input current	IAINH(1)	analog channel except AN12	VAIN=VDD	2.4 to 5.5			1	μA
	IAINL(1)		VAIN=VSS	2.4 to 5.5	-1			
	IAINH(2)	AN12	VAIN=VDD	2.4 to 5.5			15	
	IAINL(2)		VAIN=VSS	2.4 to 5.5	-15			

Note 6-1: The quantization error ($\pm 1/2\text{LSB}$) must be excluded from the absolute accuracy. The absolute accuracy must be measured in the microcontroller's state in which no I/O operations occur at the pins adjacent to the analog input channel.

Note 6-2: The conversion time refers to the period from the time an instruction for starting a conversion process till the time the conversion results register(s) are loaded with a complete digital conversion value corresponding to the analog input value.

The conversion time is 2 times the normal-time conversion time when:

- The first AD conversion is performed in the 12-bit AD conversion mode after a system reset.
- The first AD conversion is performed after the AD conversion mode is switched from 8-bit to 12-bit conversion mode.

LC87F2J32A

<8bits AD Converter Mode at Ta = -40 to +85°C>

Parameter	Symbol	Pin/Remarks	Conditions	Specification				
				V _{DD} [V]	min	typ	max	unit
Resolution	N	AN0(P00) to		2.4 to 5.5		8		bit
Absolute accuracy	ET	AN7(P07) AN8(P70)	(Note 6-1)	2.4 to 5.5			±1.5	LSB
Conversion time	TCAD	AN9(P71) AN10(XT1) AN11(XT2) AN12(CF1) AN13(CF2)	• See Conversion time calculation formulas. (Note 6-2)	4.0 to 5.5	20		90	μs
			• See Conversion time calculation formulas. (Note 6-2)	3.0 to 5.5	40		90	
Analog input voltage range	VAIN			2.4 to 5.5	V _{SS}		V _{DD}	V
Analog port input current	I _{AINH} (1)	analog channel except AN12	V _{AIN} =V _{DD}	2.4 to 5.5			1	μA
	I _{AINL} (1)		V _{AIN} =V _{SS}	2.4 to 5.5	-1			
	I _{AINH} (2)	AN12	V _{AIN} =V _{DD}	2.4 to 5.5			15	
	I _{AINL} (2)		V _{AIN} =V _{SS}	2.4 to 5.5	-15			

Conversion time calculation formulas:

12bits AD Converter Mode: TCAD(Conversion time)=((52/(AD division ratio))+2)×(1/3)×tCYC

8bits AD Converter Mode: TCAD(Conversion time)=((32/(AD division ratio))+2)×(1/3)×tCYC

External oscillation (FmCF)	Operating supply voltage range (V _{DD})	System division ratio (SYSDIV)	Cycle time (tCYC)	AD division ratio (ADDIV)	AD conversion time (TCAD)	
					12bit AD	8bit AD
CF-12MHz	4.0V to 5.5V	1/1	250ns	1/8	34.8μs	21.5μs
	3.0V to 5.5V	1/1	250ns	1/16	69.5μs	42.8μs
CF-10MHz	4.0V to 5.5V	1/1	300ns	1/8	41.8μs	25.8μs
	3.0V to 5.5V	1/1	300ns	1/16	83.4μs	51.4μs
CF-4MHz	3.0V to 5.5V	1/1	750ns	1/8	104.5μs	64.5μs
	2.4V to 3.6V	1/1	750ns	1/32	416.5μs	256.5μs

Note 6-1: The quantization error (±1/2LSB) must be excluded from the absolute accuracy. The absolute accuracy must be measured in the microcontroller's state in which no I/O operations occur at the pins adjacent to the analog input channel.

Note 6-2: The conversion time refers to the period from the time an instruction for starting a conversion process till the time the conversion results register(s) are loaded with a complete digital conversion value corresponding to the analog input value.

The conversion time is 2 times the normal-time conversion time when:

- The first AD conversion is performed in the 12-bit AD conversion mode after a system reset.
- The first AD conversion is performed after the AD conversion mode is switched from 8-bit to 12-bit conversion mode.

Power-on reset (POR) Characteristics at Ta = -40 to +85°C, V_{SS1} = V_{SS2} = V_{SS3} = 0V

Parameter	Symbol	Pin/Remarks	Conditions	Option selected voltage	Specification			
					min	typ	max	unit
POR release voltage	PORRL		• Select from option. (Note 7-1)	1.67V	1.55	1.67	1.79	V
				1.97V	1.85	1.97	2.09	
				2.07V	1.95	2.07	2.19	
				2.37V	2.25	2.37	2.49	
				2.57V	2.45	2.57	2.69	
				2.87V	2.75	2.87	2.99	
				3.86V	3.73	3.86	3.99	
				4.35V	4.21	4.35	4.49	
Detection voltage unknown state	POUKS		• See Fig. 8. (Note 7-2)			0.7	0.95	
Power supply rise time	PORIS		• Power supply rise time from 0V to 1.6V.				100	ms

Note7-1: The POR release level can be selected out of 8 levels only when the LVD reset function is disabled.

Note7-2: POR is in an unknown state before transistors start operation.

LC87F2J32A

Low voltage detection reset (LVD) Characteristics at Ta = -40 to +85°C, V_{SS1}=V_{SS2}=V_{SS3}=0V

Parameter	Symbol	Pin/Remarks	Conditions	Specification				
				Option selected voltage	min	typ	max	unit
LVD reset Voltage (Note 8-2)	LVDET		<ul style="list-style-type: none"> • Select from option. (Note 8-1) (Note 8-3) • See Fig. 9. 	1.91V	1.81	1.91	2.01	V
				2.01V	1.91	2.01	2.11	
				2.31V	2.21	2.31	2.41	
				2.51V	2.41	2.51	2.61	
				2.81V	2.71	2.81	2.91	
				3.79V	3.69	3.79	3.89	
				4.28V	4.18	4.28	4.38	
LVD hysteresis width	LVHYS			1.91V		55		mV
				2.01V		55		
				2.31V		55		
				2.51V		55		
				2.81V		60		
				3.79V		65		
Detection voltage unknown state	LVUKS		<ul style="list-style-type: none"> • See Fig. 9. (Note 8-4) 			0.7	0.95	V
Low voltage detection minimum width (Reply sensitivity)	TLVDW		<ul style="list-style-type: none"> • LVDET-0.5V • See Fig. 10. 		0.2			ms

Note8-1: The LVD reset level can be selected out of 7 levels only when the LVD reset function is enabled.

Note8-2: LVD reset voltage specification values do not include hysteresis voltage.

Note8-3: LVD reset voltage may exceed its specification values when port output state changes and/or when a large current flows through port.

Note8-4: LVD is in an unknown state before transistors start operation.

LC87F2J32A

Consumption Current Characteristics at Ta = -40°C to +85°C, VSS1 = VSS2 = VSS3 = 0V

Parameter	Symbol	Pin/ Remarks	Conditions	Specification				
				VDD[V]	min	typ	max	unit
Normal mode consumption current (Note 9-1) (Note 9-2)	IDDOP(1)	VDD1 =VDD2 =VDD3	<ul style="list-style-type: none"> • FmCF=12MHz ceramic oscillation mode • System clock set to 12MHz side • Internal Low speed and Medium speed RC oscillation stopped. • Frequency variable RC oscillation stopped. • 1/1 frequency division ratio 	2.7 to 5.5		6.6	11.3	mA
				2.7 to 3.6		4.0	7.3	
	IDDOP(2)		<ul style="list-style-type: none"> • CF1=24MHz external clock • System clock set to CF1 side • Internal Low speed and Medium speed RC oscillation stopped. • Frequency variable RC oscillation stopped. • 1/2 frequency division ratio 	3.0 to 5.5		8.0	12.7	
				3.0 to 3.6		4.6	7.6	
	IDDOP(3)		<ul style="list-style-type: none"> • FmCF=10MHz ceramic oscillation mode • System clock set to 10MHz side • Internal Low speed and Medium speed RC oscillation stopped. • Frequency variable RC oscillation stopped. • 1/1 frequency division ratio 	2.2 to 5.5		5.9	10.5	
				2.2 to 3.6		3.6	6.7	
	IDDOP(4)		<ul style="list-style-type: none"> • FmCF=4MHz ceramic oscillation mode • System clock set to 4MHz side • Internal Low speed and Medium speed RC oscillation stopped. • Frequency variable RC oscillation stopped. • 1/1 frequency division ratio 	1.8 to 5.5		2.6	6.1	
				1.8 to 3.6		1.9	3.9	
	IDDOP(5)		<ul style="list-style-type: none"> • CF oscillation low amplifier size selected. (CFLAMP=1) • FmCF=4MHz ceramic oscillation mode • System clock set to 4MHz side • Internal Low speed and Medium speed RC oscillation stopped. • Frequency variable RC oscillation stopped. • 1/4 frequency division ratio 	2.2 to 5.5		0.9	2.2	
				2.2 to 3.6		0.5	1.1	
	IDDOP(6)		<ul style="list-style-type: none"> • FsX'tal=32.768kHz Crystal oscillation mode • Internal Low speed RC oscillation stopped. • System clock set to internal Medium speed RC oscillation. • Frequency variable RC oscillation stopped. • 1/2 frequency division ratio 	1.8 to 5.5		0.5	1.5	
				1.8 to 3.6		0.3	0.8	
	IDDOP(7)		<ul style="list-style-type: none"> • FsX'tal=32.768kHz crystal oscillation mode • Internal Low speed and Medium speed RC oscillation stopped. • System clock set to 8MHz with Frequency variable RC oscillation • 1/1 frequency division ratio 	2.7 to 5.5		5.6	10.8	
				2.7 to 3.6		3.8	6.6	
	IDDOP(8)		<ul style="list-style-type: none"> • External FsX'tal and FmCF oscillation stopped. • System clock set to internal Low speed RC oscillation. • Internal Medium speed RC oscillation stopped. • Frequency variable RC oscillation stopped. • 1/1 frequency division ratio 	1.8 to 5.5		70	173	
				1.8 to 3.6		47	106	
IDDOP(9)	<ul style="list-style-type: none"> • External FsX'tal and FmCF oscillation stopped. • System clock set to internal Low speed RC oscillation. • Internal Medium speed RC oscillation stopped. • Frequency variable RC oscillation stopped. • 1/1 frequency division ratio • Ta=-10 to +50°C 	5.0		70	145	μA		
		3.3		47	86			
		2.5		35	65			

Note 9-1: The consumption current value includes none of the currents that flow into the output Tr and internal pull-up resistors.

Note9-2: The consumption current values do not include operational current of LVD function if not specified

Continued on next page.

LC87F2J32A

Continued from preceding page.

Parameter	Symbol	Pin/ Remarks	Conditions	Specification				
				V _{DD} [V]	min	typ	max	unit
Normal mode consumption current (Note 9-1) (Note 9-2)	IDDOP(10)	V _{DD} 1	<ul style="list-style-type: none"> • FsX'tal=32.768kHz crystal oscillation mode • System clock set to 32.768kHz side • Internal Low speed and Medium speed RC oscillation stopped. • Frequency variable RC oscillation stopped. • 1/2 frequency division ratio 	1.8 to 5.5		27	120	μA
				1.8 to 3.6		13	59	
	IDDOP(11)		<ul style="list-style-type: none"> • FsX'tal=32.768kHz crystal oscillation mode • System clock set to 32.768kHz side • Internal Low speed and Medium speed RC oscillation stopped. • Frequency variable RC oscillation stopped. • 1/2 frequency division ratio • Ta=-10 to +50°C 	5.0		27	84	
				3.3		13	33	
				2.5		8.1	22	
HALT mode consumption current (Note 9-1) (Note 9-2)	IDDHALT(1)	V _{DD} 1	<ul style="list-style-type: none"> • HALT mode • FmCF=12MHz ceramic oscillation mode • System clock set to 12MHz side • Internal Low speed and Medium speed RC oscillation stopped. • Frequency variable RC oscillation stopped. • 1/1 frequency division ratio 	2.7 to 5.5		2.6	4.7	mA
				2.7 to 3.6		1.4	2.5	
	IDDHALT(2)		<ul style="list-style-type: none"> • HALT mode • CF1=24MHz external clock • System clock set to CF1 side • Internal Low speed and Medium speed RC oscillation stopped. • Frequency variable RC oscillation stopped. • 1/2 frequency division ratio 	3.0 to 5.5		4.0	6.9	
				3.0 to 3.6		2.0	3.4	
	IDDHALT(3)		<ul style="list-style-type: none"> • HALT mode • FmCF=10MHz ceramic oscillation mode • System clock set to 10MHz side • Internal Low speed and Medium speed RC oscillation stopped. • Frequency variable RC oscillation stopped. • 1/1 frequency division ratio 	2.2 to 5.5		2.2	4.4	
				2.2 to 3.6		1.2	2.3	
	IDDHALT(4)		<ul style="list-style-type: none"> • HALT mode • FmCF=4MHz ceramic oscillation mode • System clock set to 4MHz side • Internal Low speed and Medium speed RC oscillation stopped. • Frequency variable RC oscillation stopped. • 1/1 frequency division ratio 	1.8 to 5.5		1.2	3.0	
				1.8 to 3.6		0.6	1.4	
	IDDHALT(5)		<ul style="list-style-type: none"> • HALT mode • CF oscillation low amplifier size selected. (CFLAMP=1) • FmCF=4MHz ceramic oscillation mode • System clock set to 4 MHz side • Internal Low speed and Medium speed RC oscillation stopped. • Frequency variable RC oscillation stopped. • 1/4 frequency division ratio 	2.2 to 5.5		0.6	1.5	
				2.2 to 3.6		0.3	0.7	
	IDDHALT(6)		<ul style="list-style-type: none"> • HALT mode • FsX'tal=32.768 kHz crystal oscillation mode • Internal Low speed RC oscillation stopped. • System clock set to internal Medium speed RC oscillation • Frequency variable RC oscillation stopped. • 1/2 frequency division ratio 	1.8 to 5.5		0.3	0.9	
				1.8 to 3.6		0.2	0.5	

Note 9-1: The consumption current value includes none of the currents that flow into the output Tr and internal pull-up resistors.

Note9-2: The consumption current values do not include operational current of LVD function if not specified

Continued on next page.

LC87F2J32A

Continued from preceding page

Parameter	Symbol	Pin/ remarks	Conditions	Specification				
				V _{DD} [V]	min.	typ.	max.	unit
HALT mode consumption current (Note 9-1) (Note 9-2)	IDDHALT(7)	V _{DD} 1	<ul style="list-style-type: none"> • HALT mode • FsX'tal=32.768kHz crystal oscillation mode • Internal Low speed and Medium speed RC oscillation stopped. • System clock set to 8MHz with Frequency variable RC oscillation • 1/1 frequency division ratio 	2.7 to 5.5		2.5	5.0	μA
				2.7 to 3.6		1.4	2.6	
	IDDHALT(8)		<ul style="list-style-type: none"> • HALT mode • External FsX'tal and FmCF oscillation stopped. • System clock set to internal Low speed RC oscillation. • Internal Medium speed RC oscillation stopped. • Frequency variable RC oscillation stopped. • 1/1 frequency division ratio 	1.8 to 5.5		26	91	
				1.8 to 3.6		15	48	
	IDDHALT(9)		<ul style="list-style-type: none"> • HALT mode • External FsX'tal and FmCF oscillation stopped. • System clock set to internal Low speed RC oscillation. • Internal Medium speed RC oscillation stopped. • Frequency variable RC oscillation stopped. • 1/1 frequency division ratio • Ta=-10 to +50°C 	5.0		26	52	
				3.3		15	26	
				2.5		10	18	
	IDDHALT(10)		<ul style="list-style-type: none"> • HALT mode • FsX'tal=32.768 kHz crystal oscillation mode • System clock set to 32.768kHz side • Internal Low speed and Medium speed RC oscillation stopped. • Frequency variable RC oscillation stopped. • 1/2 frequency division ratio 	1.8 to 5.5		16	96	
				1.8 to 3.6		6.2	43	
	IDDHALT(11)		<ul style="list-style-type: none"> • HALT mode • FsX'tal=32.768kHz crystal oscillation mode • System clock set to 32.768kHz side • Internal Low speed and Medium speed RC oscillation stopped. • Frequency variable RC oscillation stopped. • 1/2 frequency division ratio • Ta=-10 to +50°C 	5.0		16	56	
				3.3		6.2	18	
				2.5		3.4	11	
HOLD mode consumption current (Note 9-1) (Note 9-2)	IDDHOLD(1)	V _{DD} 1	HOLD mode <ul style="list-style-type: none"> • CF1=V_{DD} or open (External clock mode) 	1.8 to 5.5		0.04	30	μA
				1.8 to 3.6		0.02	14	
	IDDHOLD(2)		HOLD mode <ul style="list-style-type: none"> • CF1=V_{DD} or open (External clock mode) • Ta=-10 to +50°C 	5.0		0.04	2.8	
				3.3		0.02	1.2	
				2.5		0.015	0.9	
	IDDHOLD(3)		HOLD mode <ul style="list-style-type: none"> • CF1=V_{DD} or open (External clock mode) • LVD option selected 	1.8 to 5.5		2.9	35	
				1.8 to 3.6		2.2	18	
	IDDHOLD(4)		HOLD mode <ul style="list-style-type: none"> • CF1=V_{DD} or open (External clock mode) • Ta=-10 to +50°C • LVD option selected 	5.0		2.9	7.2	
3.3				2.2	4.1			
2.5				1.9	3.4			
Timer HOLD mode consumption current (Note 9-1) (Note 9-2)	IDDHOLD(5)	V _{DD} 1	Timer HOLD mode <ul style="list-style-type: none"> • FsX'tal=32.768kHz crystal oscillation mode 	1.8 to 5.5		14	89	
				1.8 to 3.6		4.8	38	
	IDDHOLD(6)		Timer HOLD mode <ul style="list-style-type: none"> • FsX'tal=32.768kHz crystal oscillation mode • Ta=-10 to +50°C 	5.0		14	40	
				3.3		4.8	15	
2.5		2.4	7.6					

Note 9-1: The consumption current value includes none of the currents that flow into the output Tr and internal pull-up resistors.

Note9-2: The consumption current values do not include operational current of LVD function if not specified

LC87F2J32A

F-ROM Programming Characteristics at $T_a = -10^{\circ}\text{C}$ to $+55^{\circ}\text{C}$, $V_{SS1} = V_{SS2} = V_{SS3} = 0\text{V}$

Parameter	Symbol	Pin/Remarks	Conditions	Specification				
				$V_{DD}[\text{V}]$	min	typ	max	unit
Onboard programming current	IDDFW(1)	V_{DD}^1	• Only current of the Flash block.	2.2 to 5.5		5	10	mA
Programming time	tFW(1)		• Erasing time	2.2 to 5.5		20	30	ms
	tFW(2)		• Programming time			40	60	μs

UART (Full Duplex) Operating Conditions at $T_a = -40^{\circ}\text{C}$ to $+85^{\circ}\text{C}$, $V_{SS1} = V_{SS2} = V_{SS3} = 0\text{V}$

Parameter	Symbol	Pin/Remarks	Conditions	Specification				
				$V_{DD}[\text{V}]$	min	typ	max	unit
Transfer rate	UBR	UTX(P20), URX(P21)		1.8 to 5.5	16/3		8192/3	tCYC

Data length: 7, 8, and 9 bits (LSB first)

Stop bits: 1 bit (2-bit in continuous data transmission)

Parity bits: None

Example of Continuous 8-bit Data Transmission Mode Processing (first transmit data=55H)

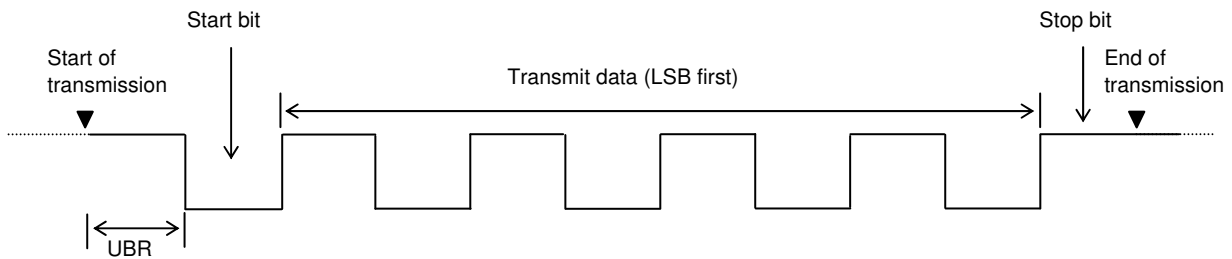

Example of Continuous 8-bit Data Reception Mode Processing (first receive data=55H)

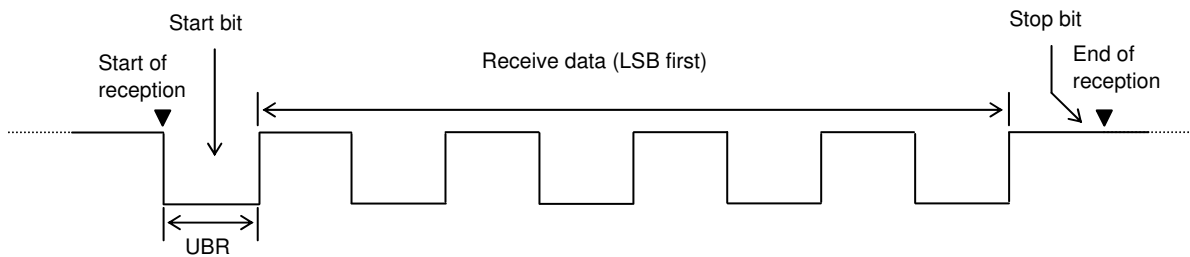

LC87F2J32A

Characteristics of a Sample Main System Clock Oscillation Circuit

Given below are the characteristics of a sample main system clock oscillation circuit that are measured using a SANYO-designated oscillation characteristics evaluation board and external components with circuit constant values with which the oscillator vendor confirmed normal and stable oscillation.

Table 1 Characteristics of a Sample Main System Clock Oscillator Circuit with a Ceramic Oscillator

- CF oscillation normal amplifier size selected (CFLAMP=0)

Nominal Frequency	Vendor Name	Oscillator Name	Circuit Constant				Operating Voltage Range [V]	Oscillation Stabilization Time		Remarks
			C1 [pF]	C2 [pF]	Rf1 [Ω]	Rd1 [Ω]		typ [ms]	max [ms]	
12MHz	MURATA	CSTCE12M0G52-R0	(10)	(10)	Open	680	2.7 to 5.5	0.1	0.5	Internal C1,C2
10MHz		CSTCE10M0G52-R0	(10)	(10)	Open	680	2.2 to 5.5	0.1	0.5	
		CSTLS10M0G53-B0	(15)	(15)	Open	680	2.2 to 5.5	0.1	0.5	
8MHz		CSTCE8M00G52-R0	(10)	(10)	Open	1.0k	2.2 to 5.5	0.1	0.5	
		CSTLS8M00G53-B0	(15)	(15)	Open	1.0k	2.2 to 5.5	0.1	0.5	
6MHz		CSTCR6M00G53-R0	(15)	(15)	Open	1.5k	2.2 to 5.5	0.1	0.5	
		CSTLS6M00G53-B0	(15)	(15)	Open	1.5k	2.2 to 5.5	0.1	0.5	
4MHz		CSTCR4M00G53-R0	(15)	(15)	Open	1.5k	1.8 to 5.5	0.2	0.6	
	CSTLS4M00G53-B0	(15)	(15)	Open	1.5k	1.8 to 5.5	0.2	0.6		

- CF oscillation low amplifier size selected (CFLAMP=1)

Nominal Frequency	Vendor Name	Oscillator Name	Circuit Constant				Operating Voltage Range [V]	Oscillation Stabilization Time		Remarks
			C1 [pF]	C2 [pF]	Rf1 [Ω]	Rd1 [Ω]		typ [ms]	max [ms]	
4MHz	MURATA	CSTCR4M00G53-R0	(15)	(15)	Open	1.0k	1.9 to 5.5	0.2	0.6	Internal C1,C2
		CSTLS4M00G53-B0	(15)	(15)	Open	1.0k	1.9 to 5.5	0.2	0.6	

The oscillation stabilization time refers to the time interval that is required for the oscillation to get stabilized after VDD goes above the operating voltage lower limit (see Figure 4).

Characteristics of a Sample Subsystem Clock Oscillator Circuit

Given below are the characteristics of a sample subsystem clock oscillation circuit that are measured using a SANYO-designated oscillation characteristics evaluation board and external components with circuit constant values with which the oscillator vendor confirmed normal and stable oscillation.

Table 2 Characteristics of a Sample Subsystem Clock Oscillator Circuit with a Crystal Oscillator

Nominal Frequency	Vendor Name	Oscillator Name	Circuit Constant				Operating Voltage Range [V]	Oscillation Stabilization Time		Remarks
			C3 [pF]	C4 [pF]	Rf2 [Ω]	Rd2 [Ω]		typ [s]	max [s]	
32.768kHz	EPSON TOYOCOM	MC-306	18	18	Open	330k	1.8 to 5.5	1.4	4.0	Applicable CL value= 7.0pF

The oscillation stabilization time refers to the time interval that is required for the oscillation to get stabilized after the instruction for starting the subclock oscillation circuit is executed and to the time interval that is required for the oscillation to get stabilized after the HOLD mode is reset (see Figure 4).

Note: The components that are involved in oscillation should be placed as close to the IC and to one another as possible because they are vulnerable to the influences of the circuit pattern.

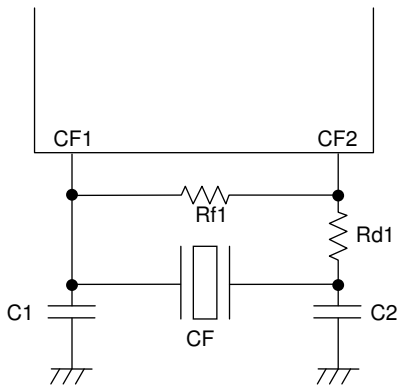

Figure 1 CF Oscillator Circuit

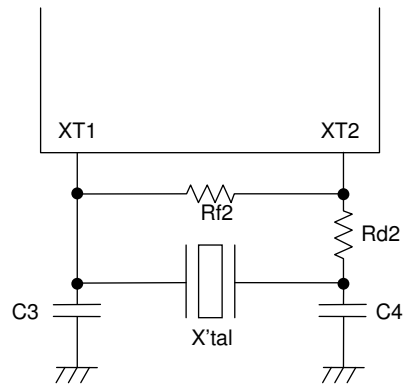
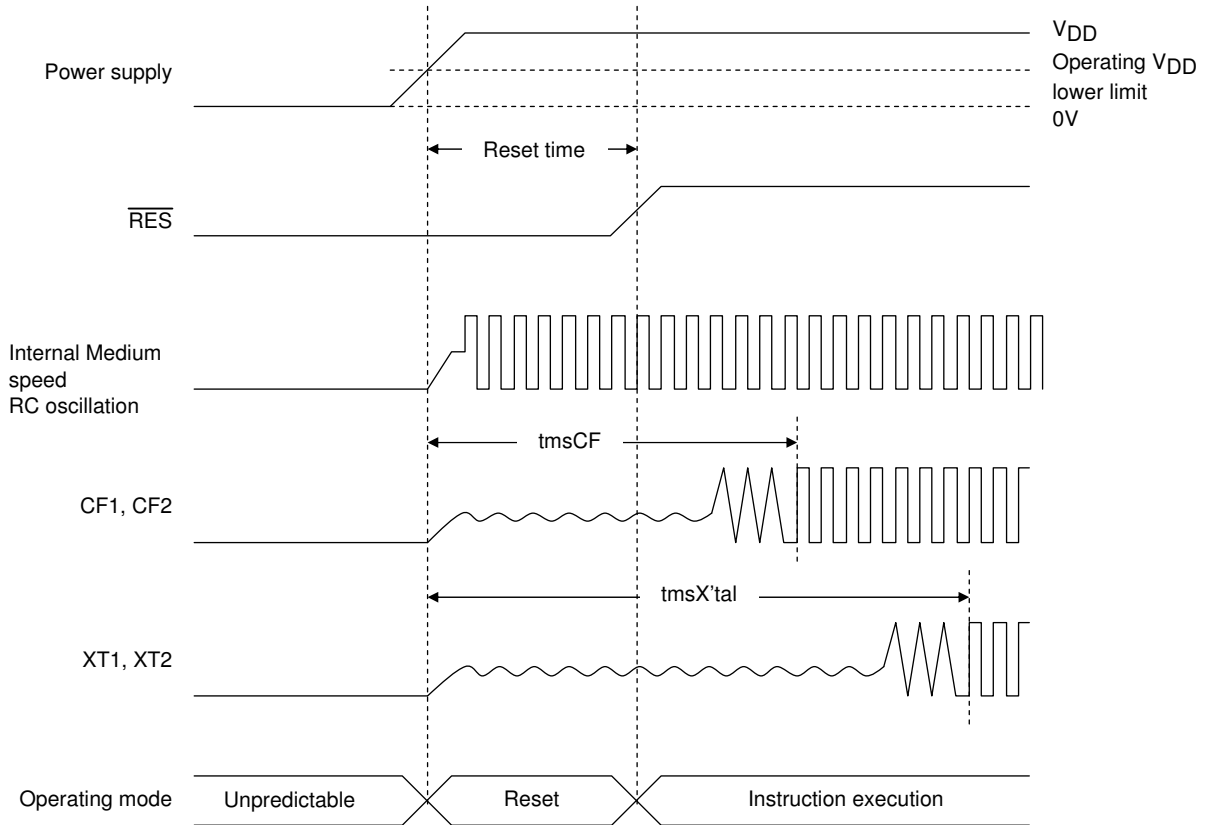

Figure 2 XT Oscillator Circuit

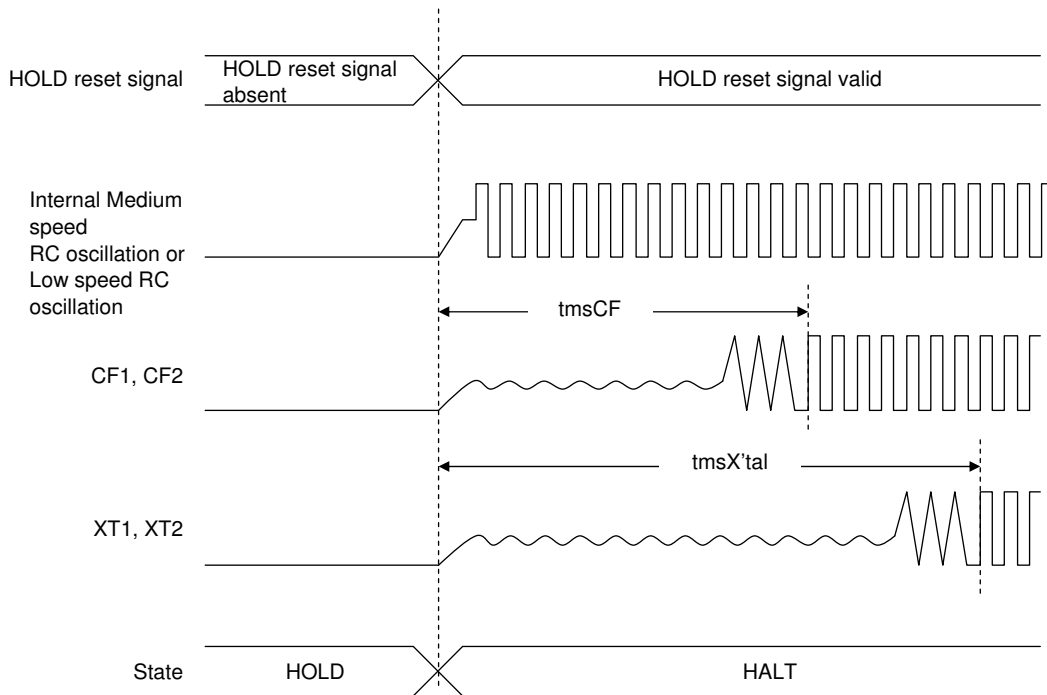

Figure 3 AC Timing Measurement Point

LC87F2J32A



Reset Time and Oscillation Stabilization Time



HOLD Reset Signal and Oscillation Stabilization Time

Note: External oscillation circuit is selected.

Figure 4 Oscillation Stabilization Times

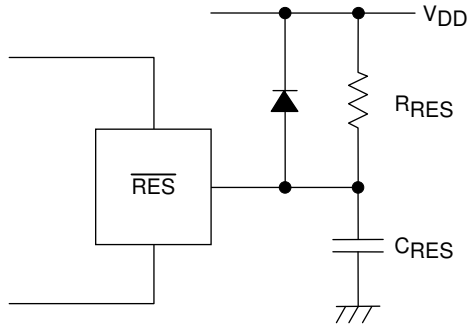

Note:
External circuits for reset may vary depending on the usage of POR and LVD. Please refer to the user's manual for more information.

Figure 5 Reset Circuit

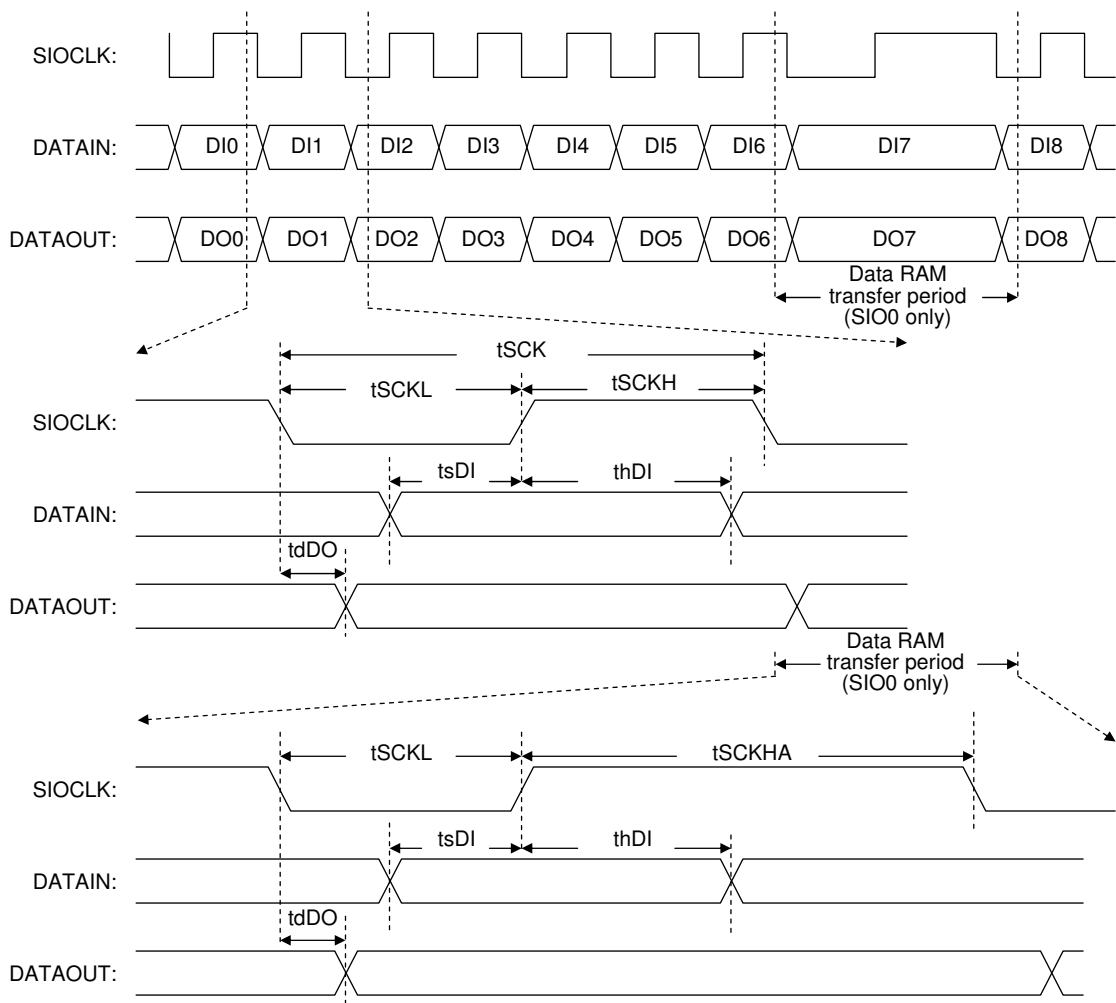

Figure 6 Serial I/O Waveforms

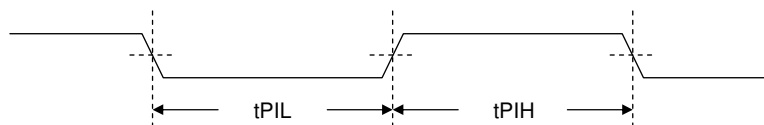

Figure 7 Pulse Input Timing Signal Waveform

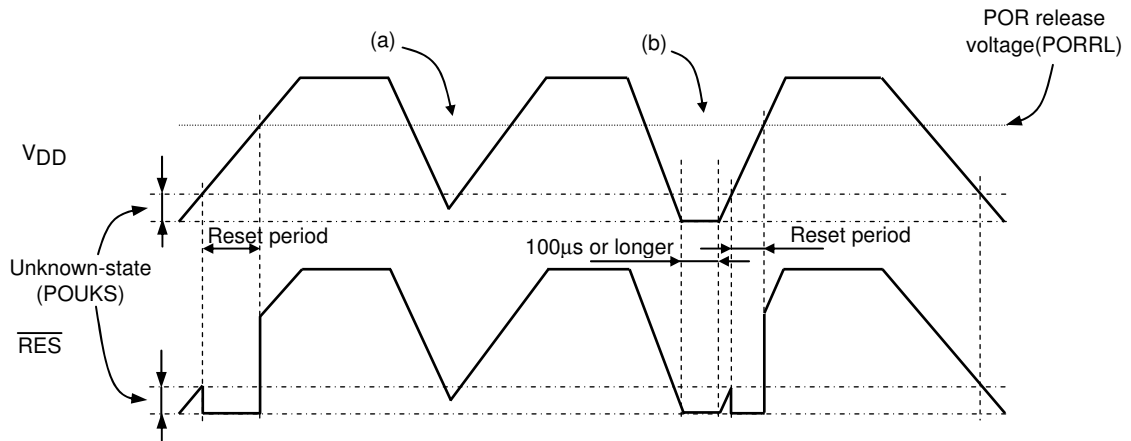

Figure 8 Waveform observed when only POR is used (LVD not used)
(RESET pin: Pull-up resistor RRES only)

- The POR function generates a reset only when power is turned on starting at the VSS level.
- No stable reset will be generated if power is turned on again when the power level does not go down to the VSS level as shown in (a). If such a case is anticipated, use the LVD function together with the POR function or implement an external reset circuit.
- A reset is generated only when the power level goes down to the VSS level as shown in (b) and power is turned on again after this condition continues for 100µs or longer.

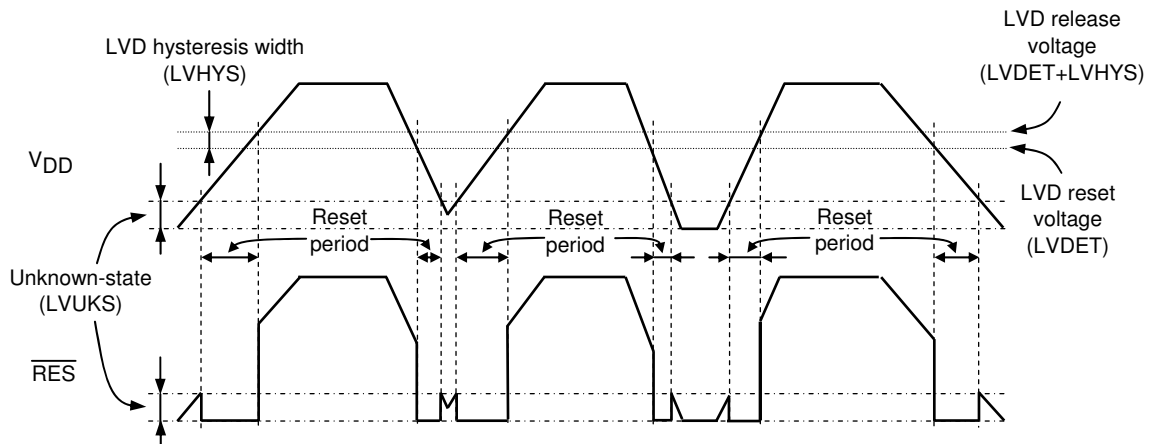

Figure 9 Waveform observed when both POR and LVD functions are used
(RESET pin: Pull-up resistor RRES only)

- Resets are generated both when power is turned on and when the power level lowers.
- A hysteresis width (LVHYS) is provided to prevent the repetitions of reset release and entry cycles near the detection level.

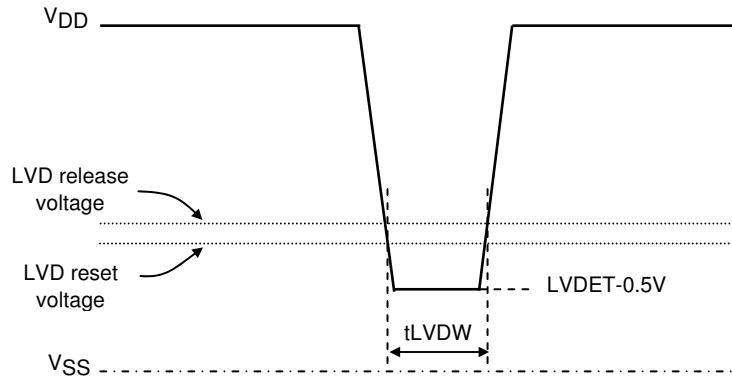

Figure 10 Low voltage detection minimum width
(Example of momentary power loss/Voltage variation waveform)

- SANYO Semiconductor Co.,Ltd. assumes no responsibility for equipment failures that result from using products at values that exceed, even momentarily, rated values (such as maximum ratings, operating condition ranges, or other parameters) listed in products specifications of any and all SANYO Semiconductor Co.,Ltd. products described or contained herein.
- SANYO Semiconductor Co.,Ltd. strives to supply high-quality high-reliability products, however, any and all semiconductor products fail or malfunction with some probability. It is possible that these probabilistic failures or malfunction could give rise to accidents or events that could endanger human lives, trouble that could give rise to smoke or fire, or accidents that could cause damage to other property. When designing equipment, adopt safety measures so that these kinds of accidents or events cannot occur. Such measures include but are not limited to protective circuits and error prevention circuits for safe design, redundant design, and structural design.
- In the event that any or all SANYO Semiconductor Co.,Ltd. products described or contained herein are controlled under any of applicable local export control laws and regulations, such products may require the export license from the authorities concerned in accordance with the above law.
- No part of this publication may be reproduced or transmitted in any form or by any means, electronic or mechanical, including photocopying and recording, or any information storage or retrieval system, or otherwise, without the prior written consent of SANYO Semiconductor Co.,Ltd.
- Any and all information described or contained herein are subject to change without notice due to product/technology improvement, etc. When designing equipment, refer to the "Delivery Specification" for the SANYO Semiconductor Co.,Ltd. product that you intend to use.
- Information (including circuit diagrams and circuit parameters) herein is for example only; it is not guaranteed for volume production.
- Upon using the technical information or products described herein, neither warranty nor license shall be granted with regard to intellectual property rights or any other rights of SANYO Semiconductor Co.,Ltd. or any third party. SANYO Semiconductor Co.,Ltd. shall not be liable for any claim or suits with regard to a third party's intellectual property rights which has resulted from the use of the technical information and products mentioned above.

This catalog provides information as of April, 2009. Specifications and information herein are subject to change without notice.