

# NBVSPA013

## 2.5 V, 212.00 MHz LVDS Voltage-Controlled Clock Oscillator (VCXO) PureEdge™ Product Series

The NBVSPA013 voltage-controlled crystal oscillator (VCXO) is designed to meet today's requirements for 2.5 V LVDS clock generation applications. These devices use a high Q fundamental mode crystal and Phase Locked Loop (PLL) multiplier to provide 212.00 MHz with a pullable range of  $\pm 100$  ppm and a frequency stability of  $\pm 50$  ppm. The silicon-based PureEdge™ products design provides users with exceptional frequency stability and reliability. They produce an ultra low jitter and phase noise LVDS differential output.

The NBVSPA013 is a member of ON Semiconductor's PureEdge clock family that provides accurate and precision clock generation solutions.

Available in the industry standard 5.0 x 7.0 x 1.8 mm SMD (CLCC) package on 16 mm tape and reel in quantities of 1,000 and 100.

### Features

- LVDS Differential Output
- Uses High Q Fundamental Mode Crystal
- Ultra Low Jitter and Phase Noise – 0.5 ps (12 kHz – 20 MHz)
- Pullable Range Minimum of  $\pm 100$  ppm
- Frequency Stability of  $\pm 50$  ppm
- Control Voltage with Positive Slope
- Voltage Control Linearity of  $\pm 10\%$
- Hermetically Sealed Ceramic SMD Packages of size 5.0 x 7.0 x 1.8 mm
- Operating Range: 2.5 V  $\pm 5\%$
- These Devices are Pb-Free and are RoHS Compliant

### Applications

- Networking
- Networking Base Stations
- Broadcasting



ON Semiconductor®

<http://onsemi.com>

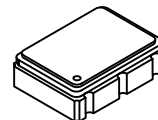

6 PIN CLCC  
LN SUFFIX  
CASE 848AB

### MARKING DIAGRAMS

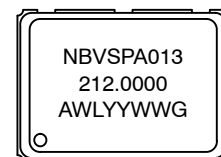

A = Assembly Location  
WL = Wafer Lot  
YY = Year  
WW = Work Week  
G = Pb-Free Package

### ORDERING INFORMATION

See detailed ordering and shipping information in the package dimensions section on page 6 of this data sheet.

# NBVSPA013

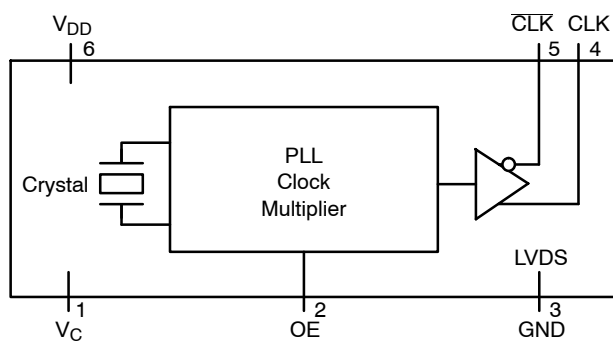

Figure 1. Simplified Logic Diagram

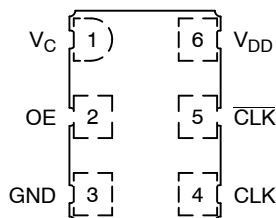

Figure 2. Pin Connections (Top View)

Table 1. PIN DESCRIPTION

Pin No.	Symbol	I/O	Description
1	$V_C$ (Note 1)	Analog Input	Analog control voltage input pin that adjusts output oscillation frequency. $f_0 = V_C = 1.25 \text{ V}$
2	OE	LVTTL/LVCMOS Control Input	Output Enable Pin. When left floating pin defaults to logic HIGH and output is active. See OE pin description Table 2.
3	GND	Power Supply	Ground at 0 V. Electrical and Case Ground.
4	CLK	LVDS Output	Non-Inverted Clock Output. Typically loaded with 100 $\Omega$ receiver termination resistor across differential pair.
5	$\overline{\text{CLK}}$	LVDS Output	Inverted Clock Output. Typically loaded with 100 $\Omega$ receiver termination resistor across differential pair.
6	$V_{DD}$	Power Supply	Positive Power Supply Voltage. Voltage should not exceed 2.5 V $\pm 5\%$ .

1. Control voltage has a positive slope with a typical linearity of  $\pm 10\%$ ;  $V_C = 1.25 \text{ V} \pm 1 \text{ V}$ .

Table 2. OUTPUT ENABLE TRI-STATE FUNCTION

OE Pin	Output Pins
Open	Active
HIGH Level	Active
LOW Level	High Z

Table 3. ATTRIBUTES

Characteristic	Value
Input Default State Resistor	170 k $\Omega$
ESD Protection	Human Body Model Machine Model
	2 kV 200 V
Meets or Exceeds JEDEC Standard EIA/JESD78 IC Latchup Test	

# NBVSPA013

**Table 4. MAXIMUM RATINGS**

Symbol	Parameter	Condition 1	Condition 2	Rating	Units
V <sub>DD</sub>	Positive Power Supply	GND = 0 V		4.6	V
V <sub>IN</sub>	Control Input (V <sub>C</sub> and OE)		V <sub>IN</sub> ≤ V <sub>DD</sub> + 200 mV V <sub>IN</sub> ≥ GND - 200 mV		V
I <sub>OSC</sub>	Output Short Circuit Current CLK to $\overline{\text{CLK}}$ CLK or $\overline{\text{CLK}}$ to GND	Continuous Continuous		12 24	mA
T <sub>A</sub>	Operating Temperature Range			-40 to +85	°C
T <sub>stg</sub>	Storage Temperature Range			-55 to +120	°C
T <sub>sol</sub>	Wave Solder	See Figure 5		260	°C

Stresses exceeding Maximum Ratings may damage the device. Maximum Ratings are stress ratings only. Functional operation above the Recommended Operating Conditions is not implied. Extended exposure to stresses above the Recommended Operating Conditions may affect device reliability.

**Table 5. DC CHARACTERISTICS** (V<sub>DD</sub> = 2.5 V ±5%, GND = 0 V, T<sub>A</sub> = -40°C to +85°C) (Note 2)

Symbol	Characteristic	Conditions	Min.	Typ.	Max.	Units
I <sub>DD</sub>	Power Supply Current			75	100	mA
V <sub>IH</sub>	OE and FSEL Input HIGH Voltage		2000		V <sub>DD</sub>	mV
V <sub>IL</sub>	OE and FSEL Input LOW Voltage		GND - 300		800	mV
I <sub>IH</sub>	Input HIGH Current OE		-100		+100	μA
I <sub>IL</sub>	Input LOW Current OE		-100		+100	μA
ΔV <sub>OD</sub>	Change in Magnitude of V <sub>OD</sub> for Complementary Output States	(Note 3)	0	1	25	mV
V <sub>OS</sub>	Offset Voltage		1125		1375	mV
ΔV <sub>OS</sub>	Change in Magnitude of V <sub>OS</sub> for Complementary Output States	(Note 3)	0	1	25	mV
V <sub>OH</sub>	Output HIGH Voltage			1425	1600	mV
V <sub>OL</sub>	Output LOW Voltage		900	1075		mV
V <sub>OD</sub>	Differential Output Voltage		250		450	mV

NOTE: Device will meet the specifications after thermal equilibrium has been established when mounted in a test socket or printed circuit board with maintained transverse airflow greater than 500 lfm. Electrical parameters are guaranteed only over the declared operating temperature range. Functional operation of the device exceeding these conditions is not implied. Device specification limit values are applied individually under normal operating conditions and not valid simultaneously.

- Measurement taken with outputs terminated with 100 ohm across differential pair. See Figure 4.
- Parameter guaranteed by design verification not tested in production.

# NBVSPA013

**Table 6. AC CHARACTERISTICS** ( $V_{DD} = 2.5 \pm 5\%$ ,  $GND = 0 V$ ,  $T_A = -40^\circ C$  to  $+85^\circ C$ ) (Note 4)

Symbol	Characteristic	Conditions	Min.	Typ.	Max.	Unit
$f_{CLKOUT}$	Output Clock Frequency	NBVSPA013		212.00		MHz
$\Delta f$	Frequency Stability	(Note 5)			$\pm 50$	ppm
$t_{jit}(\phi)$	RMS Phase Jitter	12 kHz to 20 MHz		0.4	0.9	ps
$t_{jitter}$	Cycle to Cycle, RMS	1000 Cycles		3	8	ps
	Cycle to Cycle, Peak-to-Peak	1000 Cycles		15	30	ps
	Period, RMS	10,000 Cycles		2	4	ps
	Period, Peak-to-Peak	10,000 Cycles		10	20	ps
$t_{OE/OD}$	Output Enable/Disable Time				200	ns
$F_P$	Crystal Pullability (Note 6)	$0 V \leq V_C \leq V_{DD}$	$\pm 100$			ppm
$V_{C(bw)}$	Control Voltage Bandwidth	-3 dB	20			KHz
$t_{DUTY\_CYCLE}$	Output Clock Duty Cycle (Measured at Cross Point)		45	50	55	%
$t_R$	Output Rise Time (20% and 80%)			245	400	ps
$t_F$	Output Fall Time (80% and 20%)			245	400	ps
$t_{start}$	Start-up Time			1	5	ms
	Aging	1 <sup>st</sup> Year			3	ppm
		Every Year After 1 <sup>st</sup>			1	

NOTE: Device will meet the specifications after thermal equilibrium has been established when mounted in a test socket or printed circuit board with maintained transverse airflow greater than 500 lpm. Electrical parameters are guaranteed only over the declared operating temperature range. Functional operation of the device exceeding these conditions is not implied. Device specification limit values are applied individually under normal operating conditions and not valid simultaneously.

4. Measurement taken with outputs terminated with 100 ohm across differential pair. See Figure 4.
5. Parameter guarantees 10 years of aging. Includes initial stability at 25°C, shock, vibration and first year aging.
6. Gain transfer is positive with a rate of 130 ppm/V.

**Table 7. PHASE NOISE PERFORMANCE FOR NBVSPA013**

Parameter	Characteristic	Condition	212.00 MHZ	Unit
$\phi_{NOISE}$	Output Phase-Noise Performance	100 Hz of Carrier	-82	dBc/Hz
		1 kHz of Carrier	-110	dBc/Hz
		10 kHz of Carrier	-122	dBc/Hz
		100 kHz of Carrier	-123	dBc/Hz
		1 MHz of Carrier	-132	dBc/Hz
		10 MHz of Carrier	-160	dBc/Hz

# NBVSPA013

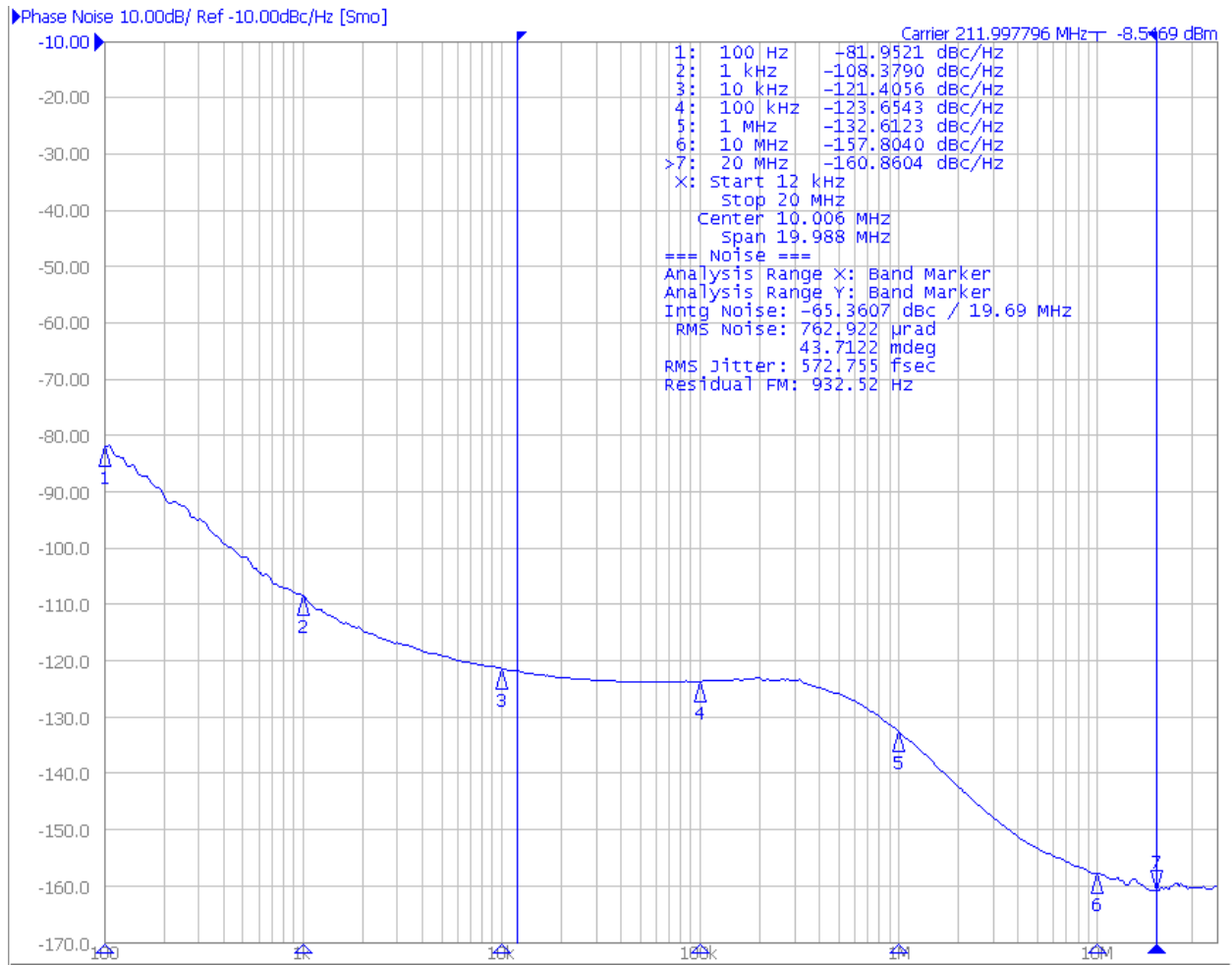
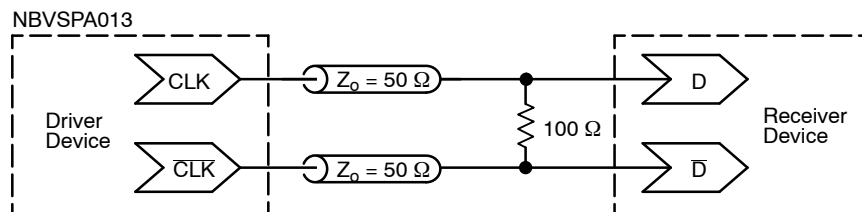

Figure 3. Typical Phase Noise Plot at 212.00 MHz

# NBVSPA013

**Table 8. RELIABILITY COMPLIANCE**

Parameter	Standard	Method
Shock	Mechanical	MIL-STD-833, Method 2002, Condition B
Solderability	Mechanical	MIL-STD-833, Method 2003
Vibration	Mechanical	MIL-STD-833, Method 2007, Condition A
Solvent Resistance	Mechanical	MIL-STD-202, Method 215
Thermal Shock	Environment	MIL-STD-833, Method 1011, Condition A
Moisture Level Sensitivity	Environment	MSL1 260°C per IPC/JEDEC J-STD-020D



**Figure 4. Typical Termination for Output Driver and Device Evaluation**

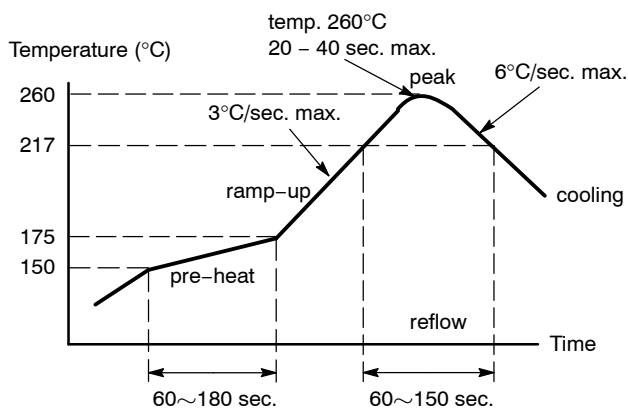

**Figure 5. Recommended Reflow Soldering Profile**

**Table 9. ORDERING INFORMATION**

Device	Output Frequency (MHz)	Package	Shipping <sup>†</sup>
5.0 x 7.0 x 1.8 mm			
NBVSPA013LN1TAG	212.0000	CLCC-6, Pb-Free	1000 / Tape & Reel
NBVSPA013LNHTAG	212.0000	CLCC-6, Pb-Free	100 / Tape & Reel

<sup>†</sup>For information on tape and reel specifications, including part orientation and tape sizes, please refer to our tape and Reel Packaging Specification Brochure, BRD8011/D

# NBVSPA013

## PACKAGE DIMENSIONS

6 PIN CLCC, 7x5, 2.54P  
CASE 848AB  
ISSUE C

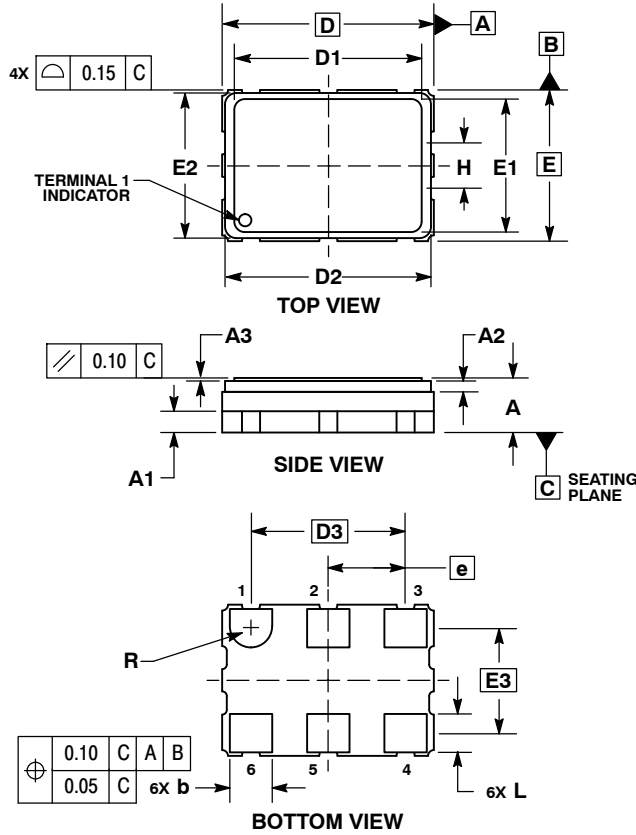

- NOTES:
1. DIMENSIONING AND TOLERANCING PER ASME Y14.5M, 1994.
  2. CONTROLLING DIMENSION: MILLIMETERS.

DIM	MILLIMETERS		
	MIN	NOM	MAX
A	1.70	1.80	1.90
A1	0.70 REF		
A2	0.36 REF		
A3	0.08	0.10	0.12
b	1.30	1.40	1.50
D	7.00 BSC		
D1	6.17	6.20	6.23
D2	6.66	6.81	6.96
D3	5.08 BSC		
E	5.00 BSC		
E1	4.37	4.40	4.43
E2	4.65	4.80	4.95
E3	3.49 BSC		
e	2.54 BSC		
H	1.80 REF		
L	1.17	1.27	1.37
R	0.70 REF		

### SOLDERING FOOTPRINT\*

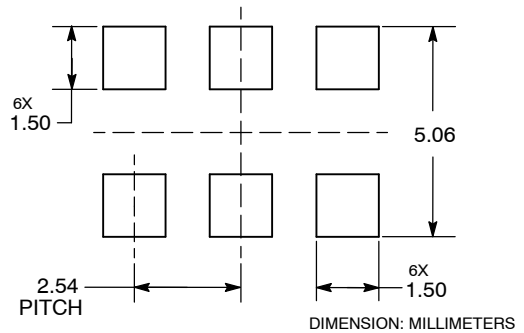

\*For additional information on our Pb-Free strategy and soldering details, please download the ON Semiconductor Soldering and Mounting Techniques Reference Manual, SOLDERRM/D.

PureEdge is a trademark of Semiconductor Components Industries, LLC (SCILLC).

ON Semiconductor and are registered trademarks of Semiconductor Components Industries, LLC (SCILLC). SCILLC reserves the right to make changes without further notice to any products herein. SCILLC makes no warranty, representation or guarantee regarding the suitability of its products for any particular purpose, nor does SCILLC assume any liability arising out of the application or use of any product or circuit, and specifically disclaims any and all liability, including without limitation special, consequential or incidental damages. "Typical" parameters which may be provided in SCILLC data sheets and/or specifications can and do vary in different applications and actual performance may vary over time. All operating parameters, including "Typicals" must be validated for each customer application by customer's technical experts. SCILLC does not convey any license under its patent rights nor the rights of others. SCILLC products are not designed, intended, or authorized for use as components in systems intended for surgical implant into the body, or other applications intended to support or sustain life, or for any other application in which the failure of the SCILLC product could create a situation where personal injury or death may occur. Should Buyer purchase or use SCILLC products for any such unintended or unauthorized application, Buyer shall indemnify and hold SCILLC and its officers, employees, subsidiaries, affiliates, and distributors harmless against all claims, costs, damages, and expenses, and reasonable attorney fees arising out of, directly or indirectly, any claim of personal injury or death associated with such unintended or unauthorized use, even if such claim alleges that SCILLC was negligent regarding the design or manufacture of the part. SCILLC is an Equal Opportunity/Affirmative Action Employer. This literature is subject to all applicable copyright laws and is not for resale in any manner.

### PUBLICATION ORDERING INFORMATION

**LITERATURE FULFILLMENT:**  
Literature Distribution Center for ON Semiconductor  
P.O. Box 5163, Denver, Colorado 80217 USA  
**Phone:** 303-675-2175 or 800-344-3860 Toll Free USA/Canada  
**Fax:** 303-675-2176 or 800-344-3867 Toll Free USA/Canada  
**Email:** orderlit@onsemi.com

**N. American Technical Support:** 800-282-9855 Toll Free  
USA/Canada  
**Europe, Middle East and Africa Technical Support:**  
Phone: 421 33 790 2910  
**Japan Customer Focus Center**  
Phone: 81-3-5817-1050

**ON Semiconductor Website:** [www.onsemi.com](http://www.onsemi.com)  
**Order Literature:** <http://www.onsemi.com/orderlit>

For additional information, please contact your local Sales Representative