

Product Description

Peregrine's PE9763 is a high performance fractional-N PLL capable of frequency synthesis up to 3.2 GHz. The device is designed for superior phase noise performance while providing an order of magnitude reduction in current consumption, when compared with the existing commercial space PLLs.

The PE9763 features a 10/11 dual modulus prescaler, counters, a delta sigma modulator, a phase comparator and a charge pump as shown in Figure 1. Counter values are programmable through either a serial interface or directly hard-wired.

PE9763 is optimized for commercial space applications. Single Event Latch up (SEL) is physically impossible and Single Event Upset (SEU) is better than 10⁻⁹ errors per bit / day. Fabricated in Peregrine's patented UTSi® (Ultra Thin Silicon) CMOS technology, the PE9763 offers excellent RF performance and intrinsic radiation tolerance.

3.2 GHz Delta-Sigma modulated Fractional-N Frequency Synthesizer for Low Phase Noise Applications

Features

- 3.2 GHz operation
- ÷10/11 dual modulus prescaler
- Selectable phase detector or charge pump output
- Serial or Direct mode access
- Frequency selectivity: Comparison frequency / 2¹⁸
- Low power — 25 - 30 mA at 3V (phase detector / charge pump)
- Rad-Hard
- Ultra-low phase noise
- 68-lead CQFJ or Die

Figure 1. Block Diagram

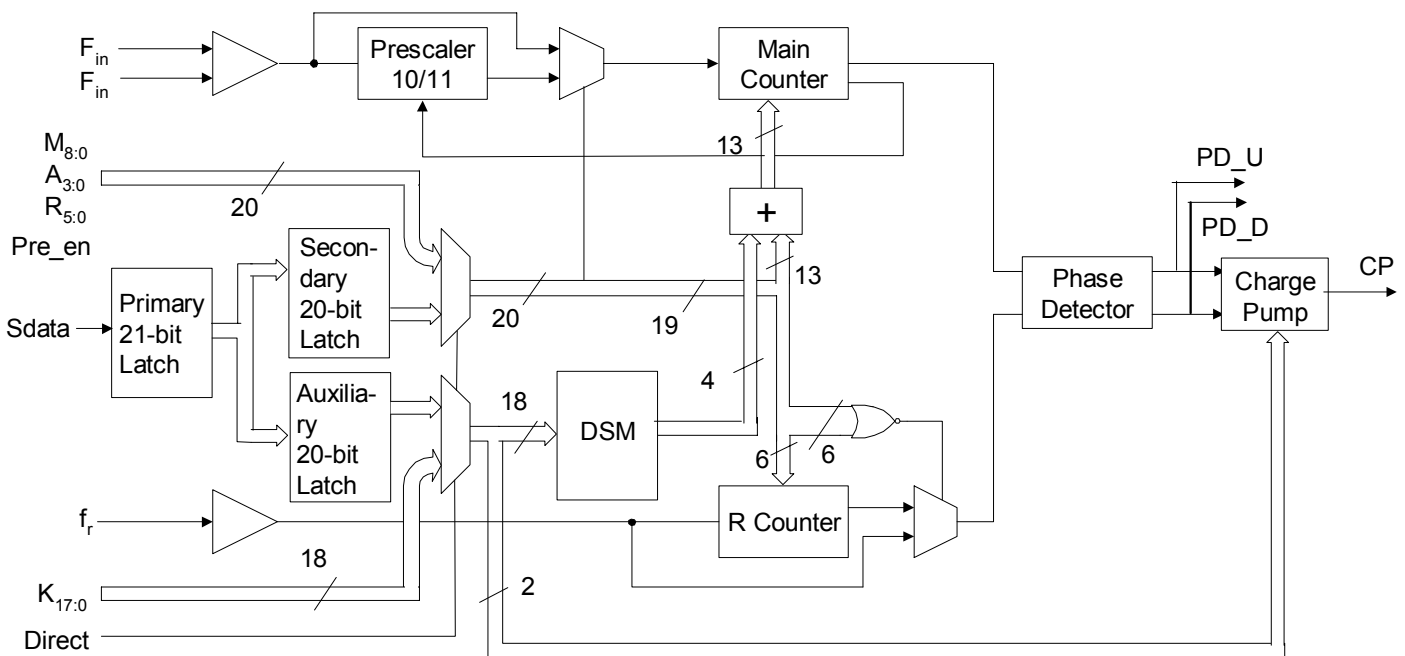
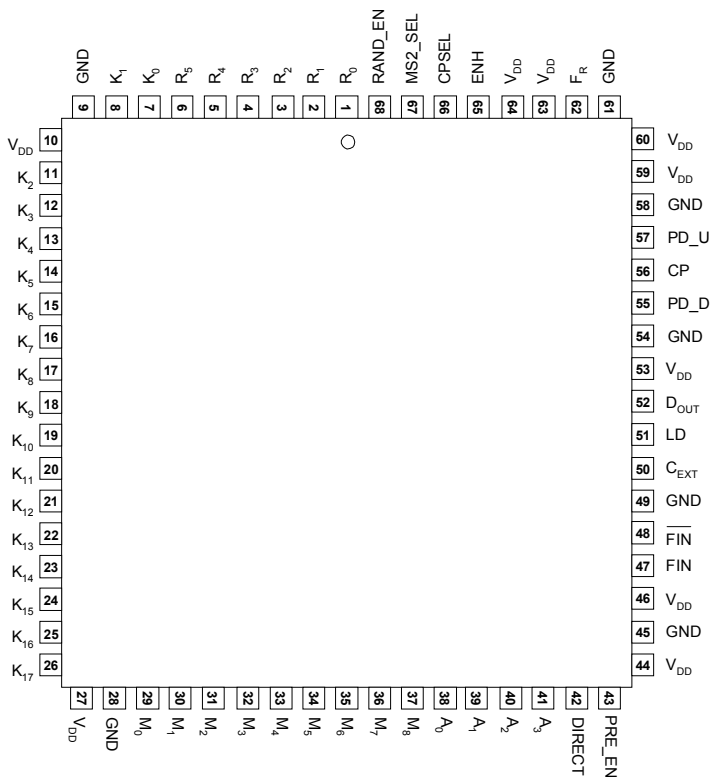

Figure 2. Pin Configuration

Table 1. Pin Descriptions

Pin No.	Pin Name	Valid Mode	Type	Description
1	R ₀	Direct	Input	R Counter bit0 (LSB).
2	R ₁	Direct	Input	R Counter bit1.
3	R ₂	Direct	Input	R Counter bit2.
4	R ₃	Direct	Input	R Counter bit3.
5	R ₄	Direct	Input	R Counter bit4.
6	R ₅	Direct	Input	R Counter bit5 (MSB).
7	K ₀	Direct	Input	K Counter bit0 (LSB).
8	K ₁	Direct	Input	K Counter bit1.
9	GND		Downbond	Digital core ground.
	GND		Downbond	ESD ground.
10	V _{DD}		(Note 1)	ESD V _{DD} .
	V _{DD}		(Note 1)	Digital core V _{DD} .
11	K ₂	Direct	Input	K Counter bit2.
12	K ₃	Direct	Input	K Counter bit3.
13	K ₄	Direct	Input	K Counter bit4.
14	K ₅	Direct	Input	K Counter bit5.
15	K ₆	Direct	Input	K Counter bit6.

Pin No.	Pin Name	Valid Mode	Type	Description
16	K ₇	Direct	Input	K Counter bit7.
17	K ₈	Direct	Input	K Counter bit8.
18	K ₉	Direct	Input	K Counter bit9.
19	K ₁₀	Direct	Input	K Counter bit10.
20	K ₁₁	Direct	Input	K Counter bit11.
21	K ₁₂	Direct	Input	K Counter bit12.
22	K ₁₃	Direct	Input	K Counter bit13.
23	K ₁₄	Direct	Input	K Counter bit14.
24	K ₁₅	Direct	Input	K Counter bit15.
25	K ₁₆	Direct	Input	K Counter bit16.
26	K ₁₇	Direct	Input	K Counter bit17 (MSB).
27	V _{DD}		(Note 1)	Digital core V _{DD} .
	V _{DD}		(Note 1)	ESD V _{DD} .
28	GND		Downbond	Digital core ground.
	GND		Downbond	ESD ground.
29	M ₀	Direct	Input	M Counter bit0 (LSB).
30	M ₁	Direct	Input	M Counter bit1.
31	M ₂	Direct	Input	M Counter bit2.
32	M ₃	Direct	Input	M Counter bit3.
33	M ₄	Direct	Input	M Counter bit4.
	S_WR	Serial	Input	Serial load enable input. While S_WR is "low", Sdata can be serially clocked. Primary register data are transferred to the secondary register on S_WR or Hop_WR rising edge.
34	M ₅	Direct	Input	M Counter bit5.
	SDATA	Serial	Input	Binary serial data input. Input data entered MSB first.
35	M ₆	Direct	Input	M Counter bit6.
	SCLK	Serial	Input	Serial clock input. SDATA is clocked serially into the 20-bit primary register (E_WR "low") or the 8-bit enhancement register (E_WR "high") on the rising edge of Sclk.
36	M ₇	Direct	Input	M Counter bit7.
37	M ₈	Direct	Input	M Counter bit8 (MSB).
38	A ₀	Direct	Input	A Counter bit0 (LSB).
39	A ₁	Direct	Input	A Counter bit1.
	E_WR	Serial	Input	Enhancement register write enable. While E_WR is "high", Sdata can be serially clocked into the enhancement register on the rising edge of Sclk.
40	A ₂	Direct	Input	A Counter bit2.
41	A ₃	Direct	Input	A Counter bit3 (MSB).
42	DIRECT	Both	Input	Direct mode select. "High" enables direct mode. "Low" enables serial mode.
43	Pre_en	Direct	Input	Prescaler enable, active "low". When "high", Fin bypasses the prescaler.
44	V _{DD}		(Note 1)	Digital core V _{DD} .
45	GND		Downbond	Digital core ground.
	GND		Downbond	ESD ground.

Pin No.	Pin Name	Valid Mode	Type	Description
46	V _{DD}		(Note 1)	ESD V _{DD} .
	V _{DD}		(Note 1)	Prescaler V _{DD} .
47	F _{in}	Both	Input	Prescaler input from the VCO. 3.2 GHz max frequency.
48	\overline{F}_{in}	Both	Input	Prescaler complementary input. A bypass capacitor should be placed as close as possible to this pin and be connected in series with a 50 Ω resistor directly to the ground plane.
49	GND		Downbond	Prescaler ground.
	GND		Downbond	Prescaler ground.
	GND		Downbond	Output driver/charge pump ground.
50	CEXT	Both	Output	Logical "NAND" of PD_U and PD_D terminated through an on chip, 2 kΩ series resistor. Connecting Cext to an external capacitor will low pass filter the input to the inverting amplifier used for driving LD.
51	LD	Both	Output	Lock detect and open drain logical inversion of CEXT. When the loop is in lock, LD is high impedance, otherwise LD is a logic low ("0").
52	D _{OUT}	Both	Output	Data out function, enabled in enhancement mode.
53	V _{DD}		(Note 1)	Output driver/charge pump V _{DD} .
54	GND		Downbond	Output driver/charge pump ground.
55	PD_D	Both	Output	PD_D pulses down when f _p leads f _c . PD_U is driven to GND when CPSEL = "High".
56	CP	Both	Output	Charge pump output. Selected when CPSEL = "1". Tristate when CPSEL = "Low".
57	PD_U	Both	Output	PD_U pulses down when f _c leads f _p . PD_D is driven to GND when CPSEL = "High".
58	GND		Downbond	Output driver/charge pump ground.
59	V _{DD}		(Note 1)	Output driver/charge pump V _{DD} .
	GND		Downbond	Phase detector GND.
60	V _{DD}		(Note 1)	Phase detector V _{DD} .
	V _{DD}		(Note 1)	ESD V _{DD} .
61	GND		Downbond	ESD ground.
	GND		Downbond	Reference ground.
62	f _r	Both	Input	Reference frequency input.
63	V _{DD}		(Note 1)	Reference V _{DD} .
64	V _{DD}		(Note 1)	Digital core V _{DD} .
	GND		Downbond	Digital core ground.
65	\overline{ENH}	Both	Input	Enhancement mode. When asserted low ("0"), enhancement register bits are functional.
66	CPSEL	Both	Input	Charge pump select. "High" enables the charge pump and disables pins PD_U and PD_D by forcing them "low". A "low" Tri-states the CP and enables PD_U and PD_D.
67	MS2_SEL	Both	Input	MASH 1-1 select. "High" selects MASH 1-1 mode. "Low" selects the MASH 1-1-1 mode.
68	RND_SEL	Both	Input	K register LSB toggle enable. "1" enables the toggling of LSB. This is equivalent to having an additional bit for the LSB of K register. The frequency offset as a result of enabling this bit is the phase detector comparison frequency / 2 ¹⁹ .

Note 1: All V_{DD} pins are connected by diodes and must be supplied with the same positive voltage level.

Note 2: All digital input pins have 70 kΩ pull-down resistors to ground.

Table 2. Absolute Maximum Ratings

Symbol	Parameter/Conditions	Min	Max	Units
V_{DD}	Supply voltage	-0.3	4.0	V
V_I	Voltage on any input	-0.3	$V_{DD} + 0.3$	V
I_I	DC into any input	-10	+10	mA
I_O	DC into any output	-10	+10	mA
T_{stg}	Storage temperature range	-65	150	°C

Table 3. Operating Ratings

Symbol	Parameter/Conditions	Min	Max	Units
V_{DD}	Supply voltage	2.85	3.15	V
T_A	Operating ambient temperature range	-40	85	°C

Table 4. ESD Ratings

Symbol	Parameter/Conditions	Level	Units
V_{ESD}	ESD voltage human body model	1000	V

Note 1: Periodically sampled, not 100% tested. Tested per MIL-STD-883, M3015 C2

Electrostatic Discharge (ESD) Precautions

When handling this UltraCMOS™ device, observe the same precautions that you would use with other ESD-sensitive devices. Although this device contains circuitry to protect it from damage due to ESD, precautions should be taken to avoid exceeding the rating specified in Table 4.

Latch-Up Avoidance

Unlike conventional CMOS devices, UltraCMOS™ devices are immune to latch-up.

Table 5. DC Characteristics
 $V_{DD} = 3.0\text{ V}$, $-40^\circ\text{ C} < T_A < 85^\circ\text{ C}$, unless otherwise specified

Symbol	Parameter	Conditions	Min	Typ	Max	Units
I_{DD}	Operational supply current; Prescaler enabled, charge pump disabled	$V_{DD} = 2.85\text{ to }3.15\text{ V}$		25		mA
I_{DD}	Operational supply current; Prescaler enabled, charge pump enabled	$V_{DD} = 2.85\text{ to }3.15\text{ V}$		30		mA
I_{DD}	Operational supply current; Prescaler disabled, charge pump disabled	$V_{DD} = 2.85\text{ to }3.15\text{ V}$		10		mA
I_{DD}	Operational supply current; Prescaler disabled, charge pump enabled	$V_{DD} = 2.85\text{ to }3.15\text{ V}$		15		mA
All Digital inputs: K[17:0], R[5:0], M[8:0], A[3:0], Direct, Pre_en, Rand_en, M2_sel, Cpsel, $\bar{E}nh$ (contains a 70 k Ω pull-down resistor)						
V_{IH}	High level input voltage	$V_{DD} = 2.85\text{ to }3.15\text{ V}$	$0.7 \times V_{DD}$			V
V_{IL}	Low level input voltage	$V_{DD} = 2.85\text{ to }3.15\text{ V}$			$0.3 \times V_{DD}$	V
I_{IH}	High level input current	$V_{IH} = V_{DD} = 3.15\text{ V}$			+100	μA
I_{IL}	Low level input current	$V_{IL} = 0, V_{DD} = 3.15\text{ V}$	-1			μA
Reference Divider input: f_r						
I_{IHR}	High level input current	$V_{IH} = V_{DD} = 3.15\text{ V}$			+100	μA
I_{ILR}	Low level input current	$V_{IL} = 0, V_{DD} = 3.15\text{ V}$	-100			μA
Counter and phase detector outputs: PD_D, PD_U						
V_{OLD}	Output voltage LOW	$I_{out} = 6\text{ mA}$			0.4	V
V_{OHD}	Output voltage HIGH	$I_{out} = -3\text{ mA}$	$V_{DD} - 0.4$			V
Digital test outputs: Dout						
V_{OLD}	Output voltage LOW	$I_{out} = 200\ \mu\text{A}$			0.4	V
V_{OHD}	Output voltage HIGH	$I_{out} = -200\ \mu\text{A}$	$V_{DD} - 0.4$			V
Charge Pump output: CP						
$I_{CP} - \text{Source}$	Drive current	$V_{CP} = V_{DD} / 2$	-2.6	2	-1.4	mA
$I_{CP} - \text{Sink}$	Drive current	$V_{CP} = V_{DD} / 2$	1.4	2	2.6	mA
I_{CPL}	Leakage current	$1.0\text{ V} < V_{CP} < V_{DD} - 1.0\text{ V}$	-1		1	μA
$I_{CP} - \text{Source}$ vs. $I_{CP} - \text{Sink}$	Sink vs. source mismatch	$V_{CP} = V_{DD} / 2$ $T_A = 25^\circ\text{ C}$			25	%
I_{CP} vs. V_{CP}	Output current magnitude variation vs. voltage	$1.0\text{ V} < V_{CP} < V_{DD} - 1.0\text{ V}$ $T_A = 25^\circ\text{ C}$			15	%
Lock detect outputs: (Cext, LD)						
V_{OLC}	Output voltage LOW, Cext	$I_{out} = 0.1\text{ mA}$			0.4	V
V_{OHC}	Output voltage HIGH, Cext	$I_{out} = -0.1\text{ mA}$	$V_{DD} - 0.4$			V
V_{OLLD}	Output voltage LOW, LD	$I_{out} = 1\text{ mA}$			0.4	V

Table 6. AC Characteristics

$V_{DD} = 3.0\text{ V}$, $-40^\circ\text{ C} < T_A < 85^\circ\text{ C}$, unless otherwise specified

Symbol	Parameter	Conditions	Min	Typ	Max	Units
Control Interface and Latches (see Figures 3, 4)						
f_{Clk}	Serial data clock frequency	(Note 1)			10	MHz
t_{ClkH}	Serial clock HIGH time		30			ns
t_{ClkL}	Serial clock LOW time		30			ns
t_{DSU}	Sdata set-up time to Sclk rising edge		10			ns
t_{DHLd}	Sdata hold time after Sclk rising edge		10			ns
t_{PW}	S_WR pulse width		30			ns
t_{CWR}	Sclk rising edge to S_WR rising edge		30			ns
t_{CE}	Sclk falling edge to E_WR transition		30			ns
t_{WRC}	S_WR falling edge to Sclk rising edge		30			ns
t_{EC}	E_WR transition to Sclk rising edge		30			ns
Main Divider (Including Prescaler) (Note 4)						
F_{in}	Operating frequency		275		3200	MHz
P_{Fin}	Input level range	External AC coupling	-5		5	dBm
Main Divider (Prescaler Bypassed) (Note 4)						
F_{in}	Operating frequency		50		300	MHz
P_{Fin}	Input level range	External AC coupling	-5		5	dBm
Reference Divider						
f_r	Operating frequency	(Note 3)			100	MHz
P_{fr}	Reference input power (Note 2)	Single ended input	-2			dBm
Phase Detector						
f_c	Comparison frequency	(Note 3)			50	MHz
SSB Phase Noise ($F_{\text{in}} = 1.9\text{ GHz}$, $f_r = 20\text{ MHz}$, $f_c = 10\text{ MHz}$, $\text{LBW} = 50\text{ kHz}$, $V_{\text{DD}} = 3.0\text{ V}$, $\text{Temp} = 25^\circ\text{ C}$) (Note 4)						
Φ_{N}	Phase Noise	1 kHz Offset		-88		dBc/Hz
Φ_{N}	Phase Noise	10 kHz Offset		-92		dBc/Hz

Note 1: fclk is verified during the functional pattern test. Serial programming sections of the functional pattern are clocked at 10 MHz to verify fclk specification.

Note 2: CMOS logic levels can be used to drive reference input if DC coupled. Voltage input needs to be a minimum of 0.5 Vp-p. For optimum phase noise performance, the reference input falling edge rate should be faster than 80mV/ns.

Note 3: Parameter is guaranteed through characterization only and is not tested.

Note 4: Parameter below are not tested for die sales. These parameters are verified during the element evaluation per the die flow.

Functional Description

The PE9763 consists of counters, a prescaler, an 18-bit delta-sigma modulator (DSM), a phase detector and a charge pump. The dual modulus prescaler divides the VCO frequency by either 10 or 11, depending on the value of the modulus select. Counters “R” and “M” divide the reference and prescaler output, respectively, by integer values stored in a 20-bit register. An additional counter (“A”) is used in the modulus select logic.

The DSM modulates the “A” counter outputs in order to achieve the desired fractional step.

The phase-frequency detector generates up and down frequency control signals. These signals can be configured to drive a tri-state charge pump. Data is written into the internal registers via the three wire serial bus. There are also various operational and test modes and a lock detect output

Figure 3. Functional Block Diagram

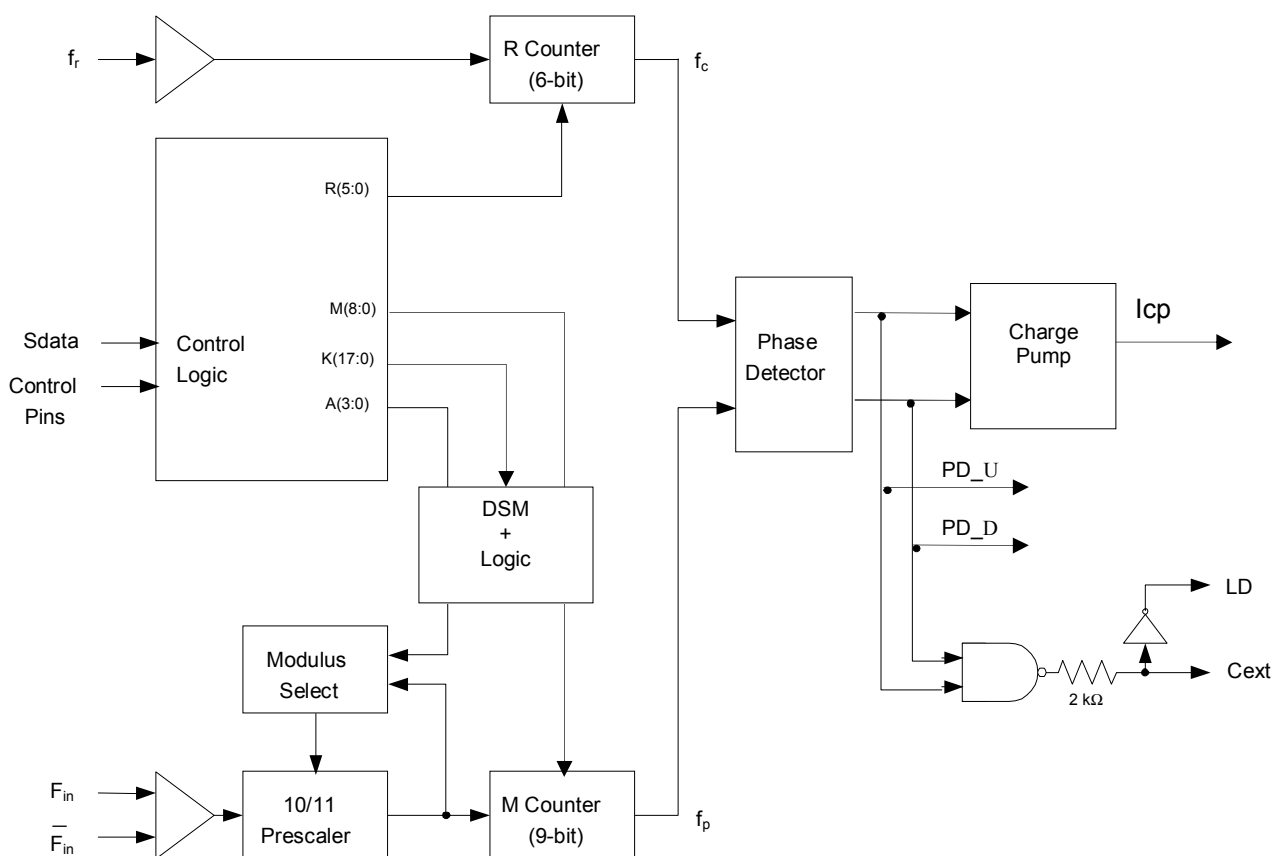

Main Counter Chain

Normal Operating Mode

Setting the Pre_en control bit “low” enables the ÷10/11 prescaler. The main counter chain then divides the RF input frequency (F_{in}) by an integer or fractional number derived from the values in the “M”, “A” counters and the DSM input word K. The accumulator size is 18 bit, so the fractional value is fixed from the ratio $K/2^{18}$. There is an additional bit in the DSM that acts like an extra bit (19th bit). This bit is enabled by asserting the pin RAND_SEL to “high”. Enabling this bit has the benefit of reducing the spurious levels. However, a small frequency offset will occur. This positive frequency offset is calculated with the following equation.

$$f_{offset} = (f_r / (R + 1)) / 2^{19} \quad (1)$$

All of the following equations do not take into account of this frequency offset. If this offset is important to a specific frequency plan, appropriate account needs to be taken.

In the normal mode, the output from the main counter chain (f_p) is related to the VCO frequency (F_{in}) by the following equation:

$$f_p = F_{in} / [10 \times (M + 1) + A + K/2^{18}] \quad (2)$$

where $A \leq M + 1$, $1 \leq M \leq 511$

When the loop is locked, F_{in} is related to the reference frequency (f_r) by the following equation:

$$F_{in} = [10 \times (M + 1) + A + K/2^{18}] \times (f_r / (R+1)) \quad (3)$$

where $A \leq M + 1$, $1 \leq M \leq 511$

A consequence of the upper limit on A is that F_{in} must be greater than or equal to $90 \times (f_r / (R+1))$ to obtain contiguous channels. The A counter can accept values as high as 15, but in typical operation it will cycle from 0 to 9 between increments in M.

Programming the M counter with the minimum allowed value of “1” will result in a minimum M counter divide ratio of “2”.

Prescaler Bypass Mode (*)

Setting the frequency control register bit Pre_en “high” allows F_{in} to bypass the ÷10/11 prescaler.

In this mode, the prescaler and A counter are powered down, and the input VCO frequency is divided by the M counter directly. The following equation relates F_{in} to the reference frequency f_r :

$$F_{in} = (M + 1) \times (f_r / (R+1)) \quad (4)$$

where $1 \leq M \leq 511$

(*) Only integer mode

In frequency bypass mode, neither A counter or K counter is used. Therefore, only integer-N operation is possible.

Reference Counter

The reference counter chain divides the reference frequency f_r down to the phase detector comparison frequency f_c .

The output frequency of the 6-bit R Counter is related to the reference frequency by the following equation:

$$f_c = f_r / (R + 1) \quad (5)$$

where $0 \leq R \leq 63$

Note that programming R with “0” will pass the reference frequency (f_r) directly to the phase detector.

Register Programming

Serial Interface Mode

While the E_WR input is “low” and the S_WR input is “low”, serial input data (Sdata input), B_0 to B_{20} , are clocked serially into the primary register on the rising edge of Sclk, MSB (B_0) first. The LSB is used as address bit. When “0”, the contents from the primary register are transferred into the secondary register on the rising edge of either S_WR according to the timing diagrams shown in Figure 4. When “1”, data is transferred to the auxiliary register according to the same timing diagram. The secondary register is used to program the various counters, while the auxiliary register is used to program the DSM.

Data are transferred to the counters as shown in Table 8 on page 10.

While the E_WR input is “high” and the S_WR input is “low”, serial input data (Sdata input), B₀ to B₇, are clocked serially into the enhancement register on the rising edge of Sclk, MSB (B₀) first. The enhancement register is double buffered to prevent inadvertent control changes during serial loading, with buffer capture of the serially entered data performed on the falling edge of E_WR according to the timing diagram shown in Figure 4. After the falling edge of E_WR, the data provide control bits as shown in Table 9 on page 10 will have their bit functionality enabled by asserting the Enh input “low”.

Direct Interface Mode

Direct Interface Mode is selected by setting the “Direct” input “high”.

Counter control bits are set directly at the pins as shown in Table 7 and Table 8.

Table 7. Secondary Register Programming

Interface Mode	Enh	R ₅	R ₄	M ₈	M ₇	Pre_en	M ₆	M ₅	M ₄	M ₃	M ₂	M ₁	M ₀	R ₃	R ₂	R ₁	R ₀	A ₃	A ₂	A ₁	A ₀	Addr
Direct	1	R ₅	R ₄	M ₈	M ₇	Pre_en	M ₆	M ₅	M ₄	M ₃	M ₂	M ₁	M ₀	R ₃	R ₂	R ₁	R ₀	A ₃	A ₂	A ₁	A ₀	X
Serial*	1	B ₀	B ₁	B ₂	B ₃	B ₄	B ₅	B ₆	B ₇	B ₈	B ₉	B ₁₀	B ₁₁	B ₁₂	B ₁₃	B ₁₄	B ₁₅	B ₁₆	B ₁₇	B ₁₈	B ₁₉	0

*Serial data clocked serially on Sclk rising edge while E_WR “low” and captured in secondary register on S_WR rising edge.

↑
MSB (first in)

↑
(last in) LSB

Table 8. Auxiliary Register Programming

Interface Mode	Enh	K ₁₇	K ₁₆	K ₁₅	K ₁₄	K ₁₃	K ₁₂	K ₁₁	K ₁₀	K ₉	K ₈	K ₇	K ₆	K ₅	K ₄	K ₃	K ₂	K ₁	K ₀	Rsrv	Rsrv	Addr
Direct	1	K ₁₇	K ₁₆	K ₁₅	K ₁₄	K ₁₃	K ₁₂	K ₁₁	K ₁₀	K ₉	K ₈	K ₇	K ₆	K ₅	K ₄	K ₃	K ₂	K ₁	K ₀	X	X	X
Serial*	1	B ₀	B ₁	B ₂	B ₃	B ₄	B ₅	B ₆	B ₇	B ₈	B ₉	B ₁₀	B ₁₁	B ₁₂	B ₁₃	B ₁₄	B ₁₅	B ₁₆	B ₁₇	B ₁₈	B ₁₉	1

*Serial data clocked serially on Sclk rising edge while E_WR “low” and captured in secondary register on S_WR rising edge.

↑
MSB (first in)

↑
(last in) LSB

Table 9. Enhancement Register Programming

Interface Mode	Enh	Reserved	Reserved	f _p output	Power Down	Counter load	MSEL output	f _e output	LD Disable
Serial*	0	B ₀	B ₁	B ₂	B ₃	B ₄	B ₅	B ₆	B ₇

*Serial data clocked serially on Sclk rising edge while E_WR “high” and captured in the double buffer on E_WR falling edge.

↑
MSB (first in)

↑
(last in) LSB

Figure 4. Serial Interface Mode Timing Diagram

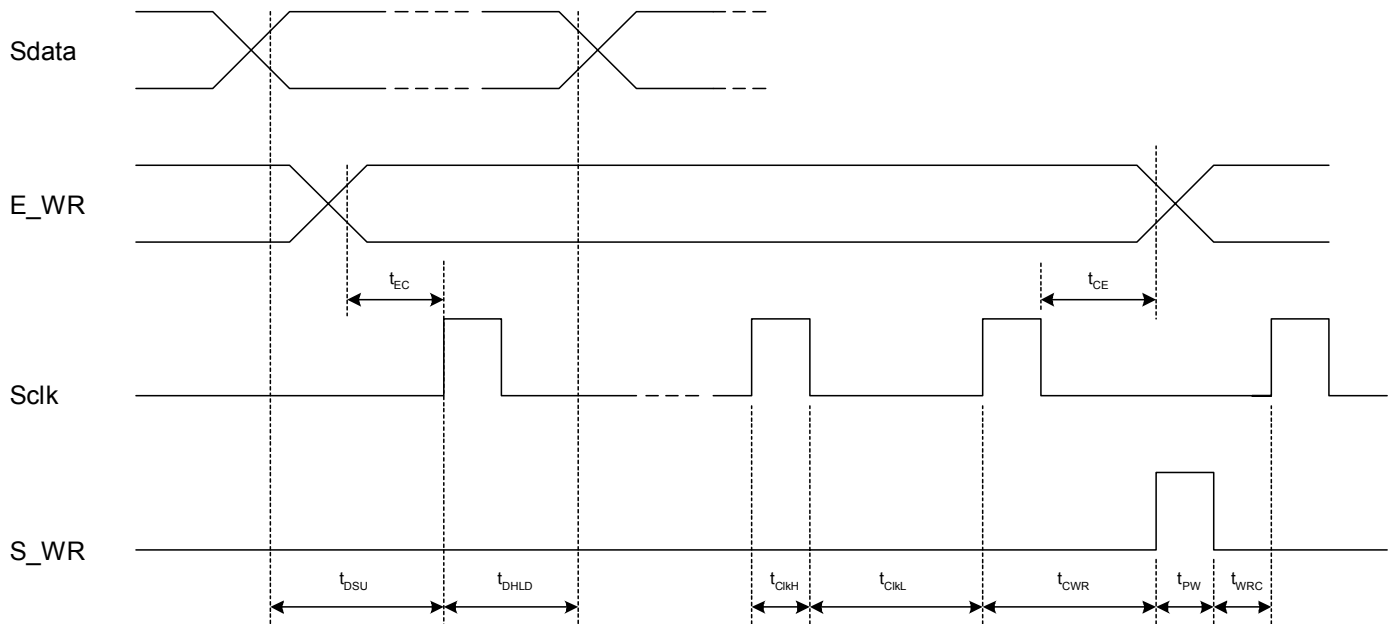

Enhancement Register

The functions of the enhancement register bits are shown below with all bits active “high”.

Table 10. Enhancement Register Bit Functionality

Bit Function		Description
Bit 0	Reserve **	Reserved.
Bit 1	Reserve **	Reserved.
Bit 2	f_p output	Drives the M counter output onto the Dout output.
Bit 3	Power down	Power down of all functions except programming interface.
Bit 4	Counter load	Immediate and continuous load of counter programming.
Bit 5	MSEL output	Drives the internal dual modulus prescaler modulus select (MSEL) onto the Dout output.
Bit 6	f_c output	Drives the reference counter output onto the Dout output.
Bit 7	LD Disable	Disables the LD pin for quieter operation.

** Program to 0

Figure 6. Typical Spurious Plot

Test Conditions: Frequency step = 200 KHz, Loop bandwidth = 80 KHz, Fout = 1.9202 GHz,
Fcomparison = 20 MHz, MASH 1-1, V_{DD} = 3 V, Temp = 25 C.

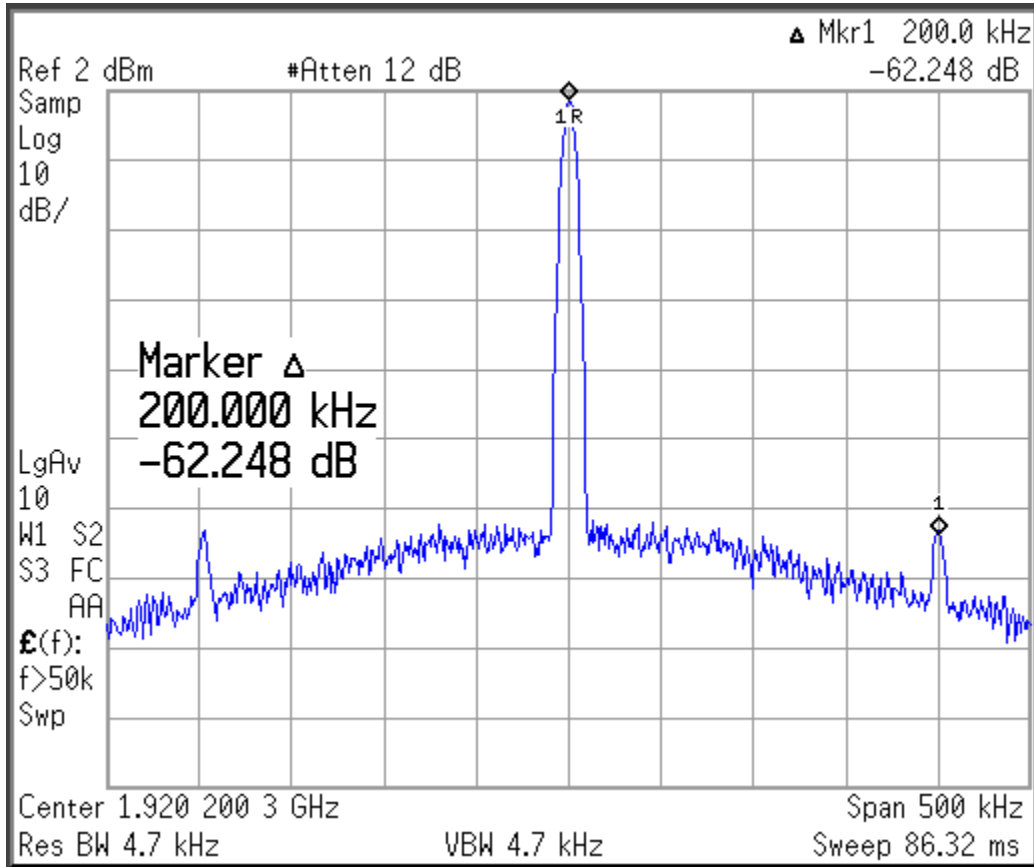

Sales Offices

The Americas

Peregrine Semiconductor Corporation

9450 Carroll Park Drive
San Diego, CA 92121
Tel: 858-731-9400
Fax: 858-731-9499

Europe

Peregrine Semiconductor Europe

Bâtiment Maine
13-15 rue des Quatre Vents
F-92380 Garches, France
Tel: +33-1-4741-9173
Fax : +33-1-4741-9173

Space and Defense Products

Americas:

Tel: 858-731-9453

Europe, Asia Pacific:

180 Rue Jean de Guiramand
13852 Aix-En-Provence Cedex 3, France
Tel: +33-4-4239-3361
Fax: +33-4-4239-7227

Peregrine Semiconductor, Asia Pacific (APAC)

Shanghai, 200040, P.R. China
Tel: +86-21-5836-8276
Fax: +86-21-5836-7652

Peregrine Semiconductor, Korea

#B-2607, Kolon Tripolis, 210
Geumgok-dong, Bundang-gu, Seongnam-si
Gyeonggi-do, 463-943 South Korea
Tel: +82-31-728-3939
Fax: +82-31-728-3940

Peregrine Semiconductor K.K., Japan

Teikoku Hotel Tower 10B-6
1-1-1 Uchisaiwai-cho, Chiyoda-ku
Tokyo 100-0011 Japan
Tel: +81-3-3502-5211
Fax: +81-3-3502-5213

For a list of representatives in your area, please refer to our Web site at: www.psemi.com

Data Sheet Identification

Advance Information

The product is in a formative or design stage. The data sheet contains design target specifications for product development. Specifications and features may change in any manner without notice.

Preliminary Specification

The data sheet contains preliminary data. Additional data may be added at a later date. Peregrine reserves the right to change specifications at any time without notice in order to supply the best possible product.

Product Specification

The data sheet contains final data. In the event Peregrine decides to change the specifications, Peregrine will notify customers of the intended changes by issuing a DCN (Document Change Notice).

The information in this data sheet is believed to be reliable. However, Peregrine assumes no liability for the use of this information. Use shall be entirely at the user's own risk.

No patent rights or licenses to any circuits described in this data sheet are implied or granted to any third party.

Peregrine's products are not designed or intended for use in devices or systems intended for surgical implant, or in other applications intended to support or sustain life, or in any application in which the failure of the Peregrine product could create a situation in which personal injury or death might occur. Peregrine assumes no liability for damages, including consequential or incidental damages, arising out of the use of its products in such applications.

The Peregrine name, logo, and UTSi are registered trademarks and UltraCMOS and HaRP are trademarks of Peregrine Semiconductor Corp.