

**Features**

- Low Power: 45 mA Typical
- 3.5 GHz operation
- ÷10/11 dual modulus prescaler
- Phase detector output
- Serial or direct hardwired mode
- Ultra-Low Phase Noise: -216 dBc/Hz
- SEU < 10<sup>-9</sup> errors / bit-day
- 100 Krad (Si) total dose
- Easily modified to be pin compatible with the PE9704, packaged in a 44-lead CQFJ (*reference application note AN23 at [www.psemi.com](http://www.psemi.com)*)

**Product Description**

Peregrine's PE97042 is a high-performance integer-N PLL capable of frequency synthesis up to 3.5 GHz. The device is designed for superior phase noise performance while providing an order of magnitude reduction in current consumption, when compared with existing commercial space PLLs.

The PE97042 features a ÷10/11 dual modulus prescaler, counters, and a phase comparator as shown in *Figure 1*. Counter values are programmable through a serial or direct hardwired mode.

The PE97042 is optimized for commercial space applications. Single Event Latch up (SEL) is physically impossible and Single Event Upset (SEU) is better than 10<sup>-9</sup> errors per bit / day. It is manufactured on Peregrine's UltraCMOS™ process, a patented variation of silicon-on-insulator (SOI) technology on a sapphire substrate, offering excellent RF performance and intrinsic radiation tolerance.

**Figure 1. Block Diagram**

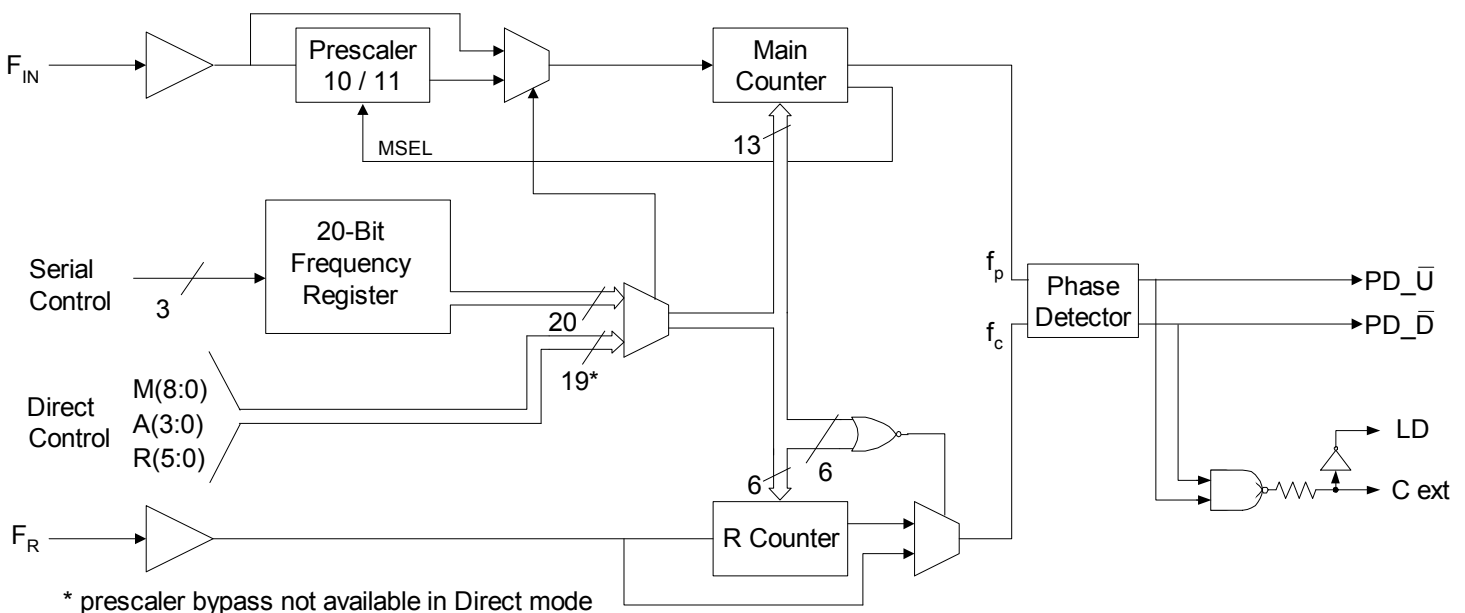

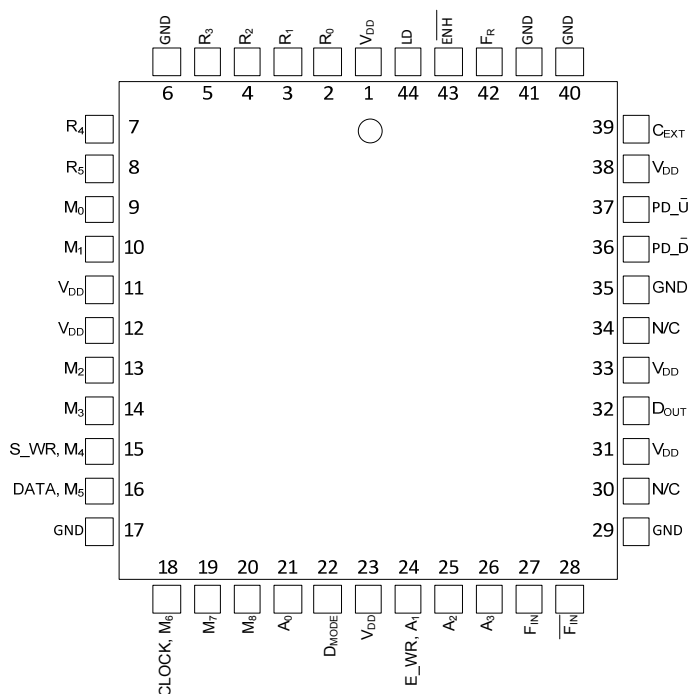
**Figure 2. Pin Configurations (Top View)**

**Figure 3. Package Type**

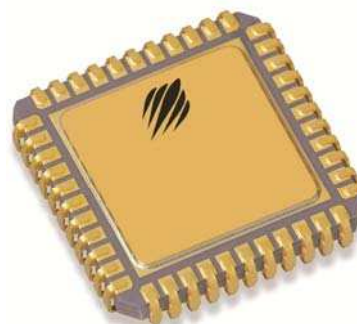
44-lead CQFJ

**Table 1. Pin Descriptions**

Pin No.	Pin Name	Interface Mode	Type	Description
1	V <sub>DD</sub>	Both	(Note 1)	Power supply input. Input may range from 2.85 V to 3.45 V. Bypassing recommended.
2	R <sub>0</sub>	Direct	Input	R Counter bit0
3	R <sub>1</sub>	Direct	Input	R Counter bit1
4	R <sub>2</sub>	Direct	Input	R Counter bit2
5	R <sub>3</sub>	Direct	Input	R Counter bit3
6	GND	Both		Ground
7	R <sub>4</sub>	Direct	Input	R Counter bit4
8	R <sub>5</sub>	Direct	Input	R Counter bit5 (MSB)
9	M <sub>0</sub>	Direct	Input	M Counter bit0
10	M <sub>1</sub>	Direct	Input	M Counter bit1
11	V <sub>DD</sub>	Both	(Note 1)	Power supply input. Input may range from 2.85 V to 3.45 V. Bypassing recommended.
12	V <sub>DD</sub>	Both	(Note 1)	Power supply input. Input may range from 2.85 V to 3.45 V. Bypassing recommended.
13	M <sub>2</sub>	Direct	Input	M Counter bit2
14	M <sub>3</sub>	Direct	Input	M Counter bit3
15	S_WR	Serial	Input	Frequency register load enable input. Buffered data is transferred to the frequency register on S_WR rising edge.
	M <sub>4</sub>	Direct	Input	M Counter bit4
16	DATA	Serial	Input	Binary serial data input. Data is entered LSB first, and is clocked serially into the 20-bit frequency control register (E_WR "low") or the 8-bit enhancement register (E_WR "high") on the rising edge of CLOCK.
	M <sub>5</sub>	Direct	Input	M Counter bit5

**Table 1. Pin Descriptions (continued)**

Pin No.	Pin Name	Interface Mode	Type	Description
17	GND	Both		Ground
18	CLOCK	Serial	Input	Clock input. Data is clocked serially into either the 20-bit primary register (E_WR “low”) or the 8-bit enhancement register (E_WR “high”) on the rising edge of CLOCK.
	M <sub>6</sub>	Direct	Input	M Counter bit6
19	M <sub>7</sub>	Direct	Input	M Counter bit7
20	M <sub>8</sub>	Direct	Input	M Counter bit8 (MSB)
21	A <sub>0</sub>	Direct	Input	A Counter bit0
22	D <sub>MODE</sub>	Both	Input	Selects direct interface mode (D <sub>MODE</sub> = 1) or serial interface mode (D <sub>MODE</sub> = 0)
23	V <sub>DD</sub>	Both	(Note 1)	Power supply input. Input may range from 2.85 V to 3.45 V. Bypassing recommended.
24	E_WR	Serial	Input	Enhancement register write enable. While E_WR is “high”, DATA can be serially clocked into the enhancement register on the rising edge of CLOCK.
	A <sub>1</sub>	Direct	Input	A Counter bit1.
25	A <sub>2</sub>	Direct	Input	A Counter bit2
26	A <sub>3</sub>	Direct	Input	A Counter bit3 (MSB)
27	F <sub>IN</sub>	Both	Input	Prescaler input from the VCO, 3.5 GHz max frequency. A 22 pF coupling capacitor should be placed as close as possible to this pin and terminated with a 50 Ω resistor to ground.
28	 F <sub>IN</sub>	Both	Input	Prescaler complementary input. A 22 pF bypass capacitor should be placed as close as possible to this pin and be connected in series with a 50 Ω resistor to ground.
29	GND	Both		Ground.
30	N/C			No connect.
31	V <sub>DD</sub>	Both	(Note 1)	Power supply input. Input may range from 2.85 V to 3.45 V. Bypassing recommended.
32	D <sub>OUT</sub>	Serial	Output	Data Out. The Main Counter output, R Counter output, or dual modulus prescaler select (MSEL) can be routed to D <sub>OUT</sub> through enhancement register programming.
33	V <sub>DD</sub>	Both	(Note 1)	Power supply input. Input may range from 2.85 V to 3.45 V. Bypassing recommended.
34	N/C			No connect.
35	GND	Both		Ground.
36	PD <sub>̄</sub> D	Both	Output	PD <sub>̄</sub> D pulses down when f <sub>b</sub> leads f <sub>c</sub> .
37	PD <sub>̄</sub> U	Both		PD <sub>̄</sub> U pulses down when f <sub>c</sub> leads f <sub>b</sub> .
38	V <sub>DD</sub>	Both	(Note 1)	Power supply input. Input may range from 2.85 V to 3.45 V. Bypassing recommended.
39	C <sub>EXT</sub>	Both	Output	Logical “NAND” of PD <sub>̄</sub> U and PD <sub>̄</sub> D, passed through an on-chip, 2 kΩ series resistor. Connecting C <sub>EXT</sub> to an external capacitor will low pass filter the input to the inverting amplifier used for driving LD.
40	GND	Both		Ground
41	GND	Both		Ground
42	F <sub>R</sub>	Both	Input	Reference frequency input
43	ENH	Both	Output	Enhancement mode. When asserted low (“0”), enhancement register bits are functional.
44	LD	Serial	Output	Lock detect output, the open-drain logical inversion of C <sub>EXT</sub> . When the loop is locked, LD is high impedance; otherwise LD is a logic low (“0”).

Notes 1. V<sub>DD</sub> pins 1, 11, 12, 23, 31, 33, 35, and 38 are connected by diodes and must be supplied with the same positive voltage level.

2. All digital input pins have 70 kΩ pull-up resistors to V<sub>DD</sub>.

**Table 2. Absolute Maximum Ratings**

Symbol	Parameter/Conditions	Min	Max	Units
$V_{DD}$	Supply voltage	-0.3	4.0	V
$V_I$	Voltage on any input	-0.3	$V_{DD} + 0.3$	V
$I_I$	DC into any input	-10	+10	mA
$I_O$	DC into any output	-10	+10	mA
$T_{stg}$	Storage temperature range	-65	150	°C

Exceeding absolute maximum ratings may cause permanent damage. Operation should be restricted to the limits in the Operating Ranges table. Operation between operating range maximum and absolute maximum for extended periods may reduce reliability.

**Table 3. Operating Ratings**

Symbol	Parameter/Conditions	Min	Max	Units
$V_{DD}$	Supply voltage	2.85	3.45	V
$T_A$	Operating ambient temperature range	-40	85	°C

**Table 4. ESD Ratings**

Symbol	Parameter/Conditions	Level	Units
$V_{ESD}$	ESD voltage (Human Body Model) – Note 1	1000	V

Note: 1. Periodically sampled, not 100% tested. Tested per MIL-STD-883, M3015 C2

### Electrostatic Discharge (ESD) Precautions

When handling this UltraCMOS™ device, observe the same precautions that you would use with other ESD-sensitive devices. Although this device contains circuitry to protect it from damage due to ESD, precautions should be taken to avoid exceeding the specified rating.

### Latch-Up Avoidance

Unlike conventional CMOS devices, UltraCMOS™ devices are immune to latch-up.

**Table 5. DC Characteristics:  $V_{DD} = 3.3\text{ V}$ ,  $-40\text{ °C} < T_A < 85\text{ °C}$ , unless otherwise specified**

Symbol	Parameter	Conditions	Min	Typ	Max	Units
$I_{DD}$	Operational supply current;	$V_{DD} = 3.30\text{ V}$				mA
	Prescaler disabled					
	Prescaler enabled				50	mA
<b>Digital Inputs: All except <math>F_R</math>, <math>\overline{F_{IN}}</math> (all digital inputs have 70 kΩ pull-up resistors)</b>						
$V_{IH}$	High level input voltage	$V_{DD} = 2.85\text{-}3.45\text{ V}$	$0.7 \times V_{DD}$			V
$V_{IL}$	Low level input voltage	$V_{DD} = 2.85\text{-}3.45\text{ V}$			$0.3 \times V_{DD}$	V
$I_{IH}$	High level input current	$V_{IH} = V_{DD} = 3.45\text{ V}$			1	μA
$I_{IL}$	Low level input current	$V_{IL} = 0, V_{DD} = 3.45\text{ V}$	-70			μA
<b>Reference Divider input: <math>F_R</math></b>						
$I_{IHR}$	High level input current	$V_{IH} = V_{DD} = 3.45\text{ V}$			100	μA
$I_{ILR}$	Low level input current	$V_{IL} = 0, V_{DD} = 3.45\text{ V}$	-100			μA
<b>Counter and phase detector outputs: <math>f_c, f_p</math></b>						
$V_{OLD}$	Output voltage LOW	$I_{out} = 6\text{ mA}$			0.4	V
$V_{OHD}$	Output voltage HIGH	$I_{out} = -3\text{ mA}$	$V_{DD} - 0.4$			V
<b>Lock detect outputs: <math>C_{EXT}, LD</math></b>						
$V_{OLC}$	Output voltage LOW, $C_{EXT}$	$I_{out} = 100\text{ μA}$			0.4	V
$V_{OHC}$	Output voltage HIGH, $C_{EXT}$	$I_{out} = -100\text{ μA}$	$V_{DD} - 0.4$			V
$V_{OLLD}$	Output voltage LOW, LD	$I_{out} = 1\text{ mA}$			0.4	V

**Table 6. AC Characteristics:  $V_{DD} = 3.3\text{ V}$ ,  $-40\text{ }^{\circ}\text{C} < T_A < 85\text{ }^{\circ}\text{C}$ , unless otherwise specified**

Symbol	Parameter	Conditions	Min	Typical	Max	Units
Control Interface and Latches (see Figures 1 and 9)						
$f_{CLK}$	CLOCK Serial data clock frequency	(Note 1)			10	MHz
$t_{CLKH}$	CLOCK Serial clock HIGH time		30			ns
$t_{CLKL}$	CLOCK Serial clock LOW time		30			ns
$t_{DSU}$	DATA set-up time after CLOCK rising edge		10			ns
$t_{DHLd}$	DATA hold time after CLOCK rising edge		10			ns
$t_{PW}$	S_WR pulse width		30			ns
$t_{CWR}$	CLOCK rising edge to S_WR rising edge.		30			ns
$t_{CE}$	CLOCK falling edge to E_WR transition		30			ns
$t_{WRC}$	S_WR falling edge to CLOCK rising edge.		30			ns
$t_{EC}$	E_WR transition to CLOCK rising edge		30			ns
$t_{MDO}$	MSEL data out delay after $F_{IN}$ rising edge	$C_L = 12\text{ pf}$			8	ns
Main Divider (Including Prescaler) <sup>4</sup>						
$P_{Fin}$	Input level range	External AC coupling $275\text{ MHz} \leq \text{Freq} \leq 3.2\text{ GHz}$	-5		5	dBm
		External AC coupling $3.2\text{ GHz} < \text{Freq} \leq 3.5\text{ GHz}$ $3.15\text{ V} \leq V_{DD} \leq 3.45\text{ V}$	0		5	dBm
Main Divider (Prescaler Bypassed) <sup>4</sup>						
$F_{IN}$	Operating frequency		50		300	MHz
$P_{Fin}$	Input level range	External AC coupling	-5		5	dBm
Reference Divider						
$F_R$	Operating frequency	(Note 3)			100	MHz
$P_{Fr}$	Reference input power <sup>2</sup>	Single-ended input	-2		10	dBm
Phase Detector						
$f_c$	Comparison frequency	(Note 3)			50	MHz
SSB Phase Noise ( $F_{in} = 1.9\text{ GHz}$ , $f_r = 20\text{ MHz}$ , $f_c = 20\text{ MHz}$ , $LBW = 50\text{ kHz}$ , $V_{DD} = 3.3\text{ V}$ , $\text{Temp} = 25\text{ }^{\circ}\text{C}$ ) <sup>4</sup>						
$\Phi_N$	Phase Noise	100 Hz Offset		-89		dBc/Hz
$\Phi_N$	Phase Noise	1 kHz Offset		-95		dBc/Hz
$\Phi_N$	Phase Noise	10 kHz Offset		-102		dBc/Hz
SSB Phase Noise ( $F_{in} = 1.9\text{ GHz}$ , $f_r = 20\text{ MHz}$ , $f_c = 20\text{ MHz}$ , $LBW = 50\text{ kHz}$ , $V_{DD} = 3.0\text{ V}$ , $\text{Temp} = 25\text{ }^{\circ}\text{C}$ ) <sup>4</sup>						
$\Phi_N$	Phase Noise	100 Hz Offset		-87		dBc/Hz
$\Phi_N$	Phase Noise	1 kHz Offset		-94		dBc/Hz
$\Phi_N$	Phase Noise	10 kHz Offset		-101		dBc/Hz

Notes: 1.  $f_{clk}$  is verified during the functional pattern test. Serial programming sections of the functional pattern are clocked at 10 MHz to verify  $f_{clk}$  specification.

2. CMOS logic levels can be used to drive the reference input. If the  $V_{DD}$  of the CMOS driver matches the  $V_{DD}$  of PLL IC, then the reference input can be DC coupled. Otherwise, the reference input should be AC coupled.

3. Parameter is guaranteed through characterization only and is not tested.

4. Parameters below are not tested for die sales. These parameters are verified during the element evaluation.

Figure 4. RF Sensitivity versus Frequency (typical device at temperature = 25 °C)

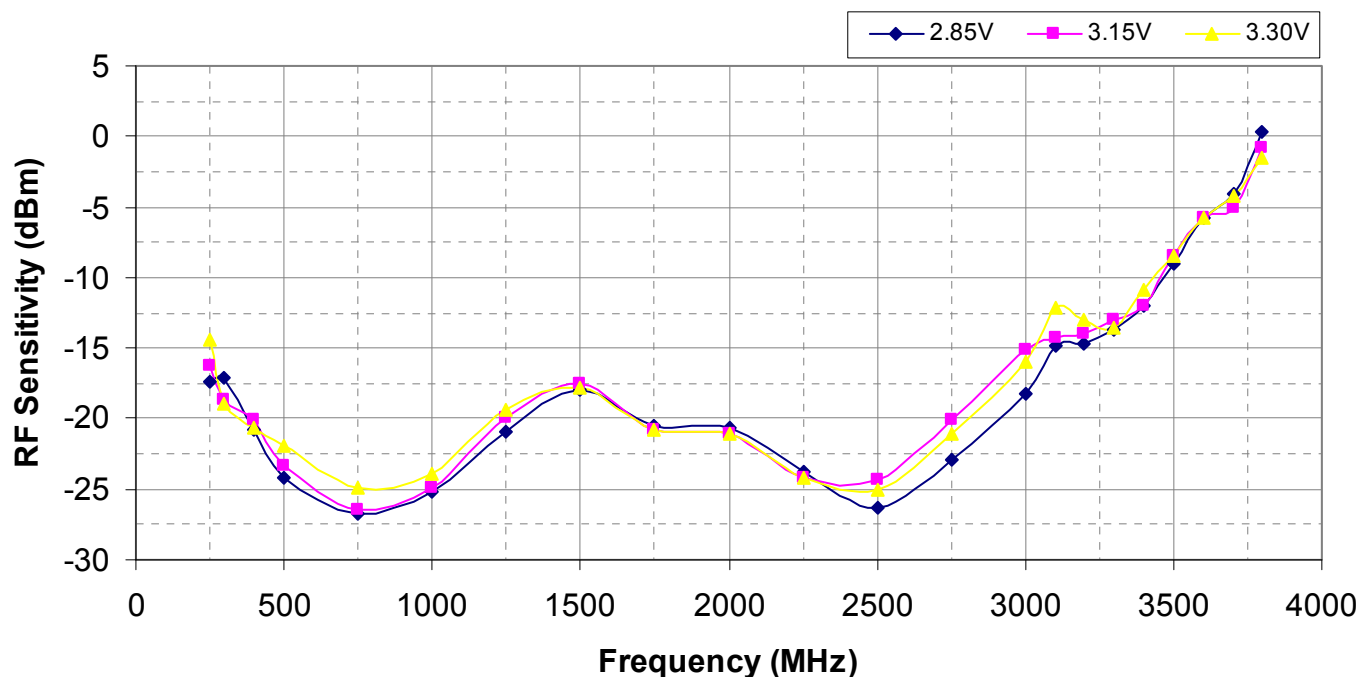
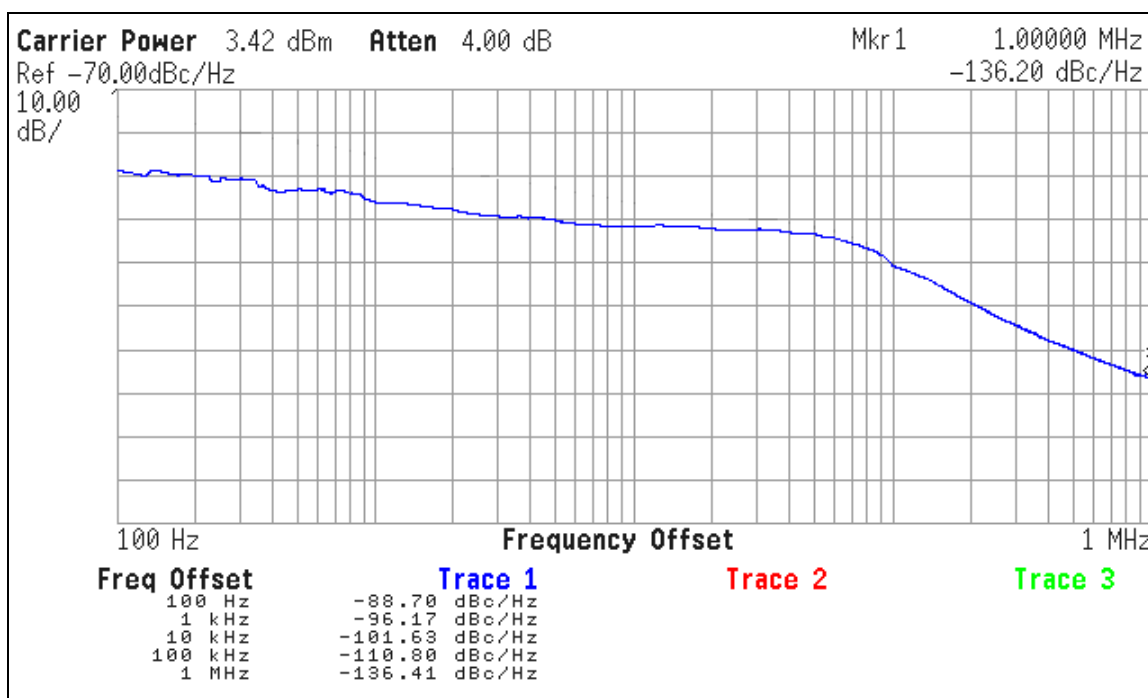
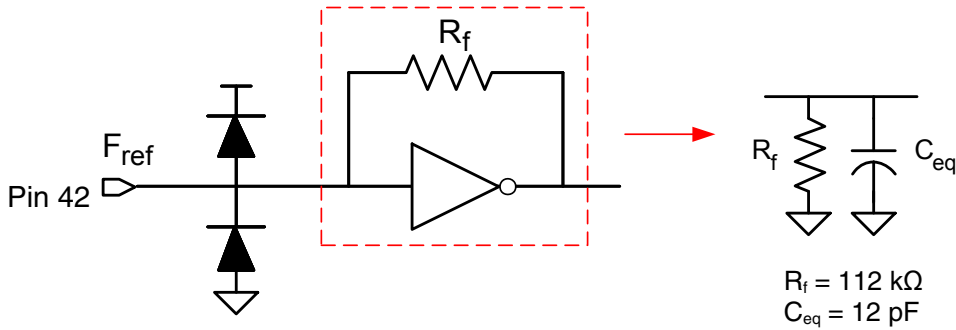

Figure 5. Typical Phase Noise for PE97042,  $V_{DD} = 3.3\text{ V}$ , Temp = 25 °C,  $F_{vco} = 1.92\text{ GHz}$ ,  $F_{comp} = 20\text{ MHz}$ , Loop Bandwidth = 50 kHz



**Figure 6. Equivalent Input Diagram: Reference Input**

Peregrine Specification 71/0032



**Figure 7. Equivalent Input Diagram: Main Input**

Peregrine Specification 71/0033

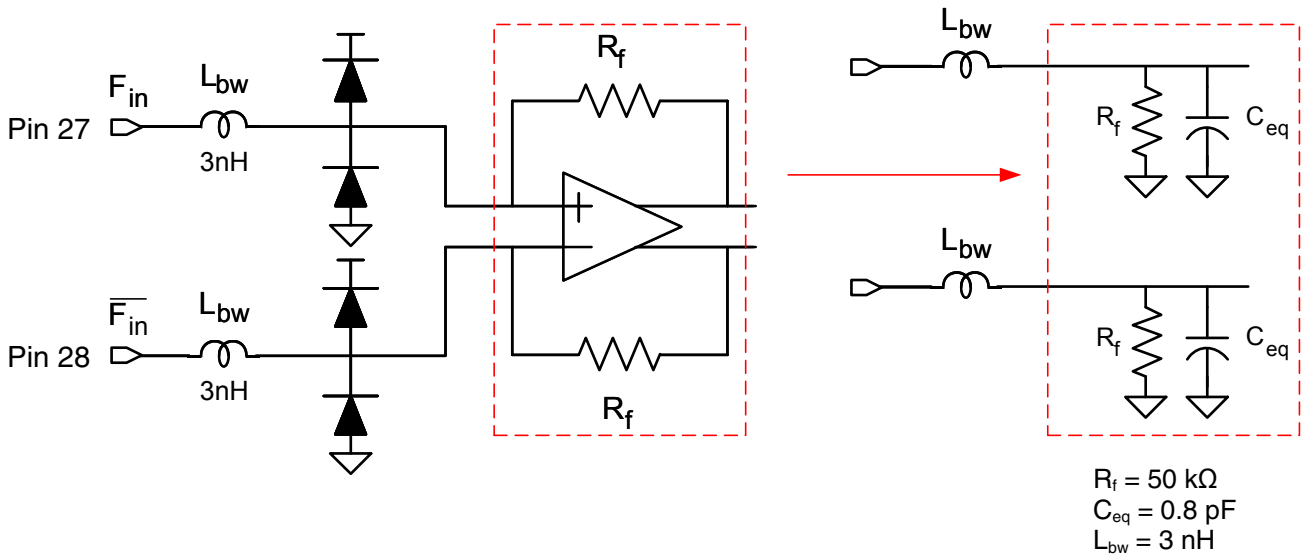

**Figure 8. Equivalent Output Diagram: PD $\bar{D}$  & PD $\bar{U}$  Outputs**

Peregrine Specification 71/0034

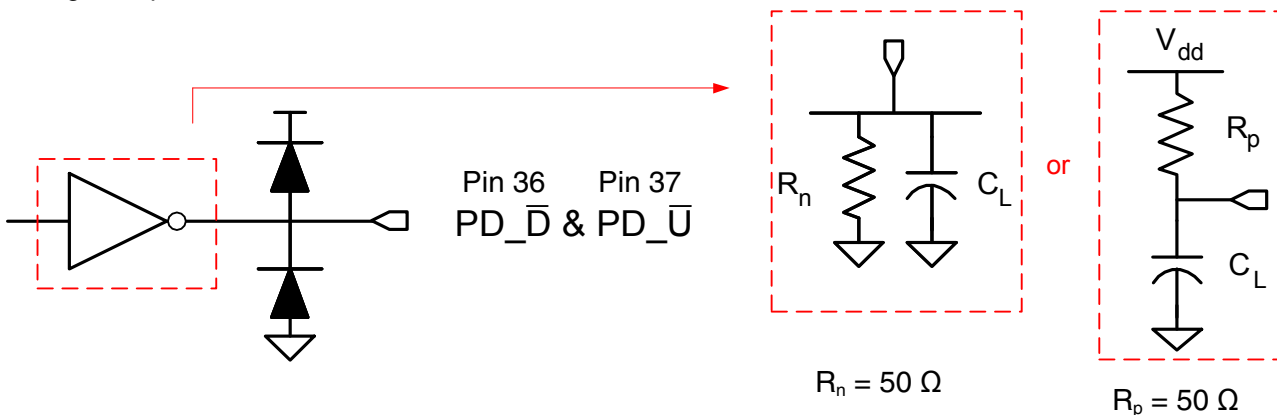

## Functional Description

The PE97042 consists of a prescaler, counters, a phase detector, and control logic. The dual modulus prescaler divides the VCO frequency by either 10 or 11, depending on the value of the modulus select. Counters “R” and “M” divide the reference and prescaler output, respectively, by integer values stored in a 20-bit register. An additional counter (“A”) is used in the modulus select logic. The phase-frequency detector generates up and down frequency control signals. The control logic includes a selectable chip interface. Data can be written via a serial bus or hardwired directly to the pins. There are also various operational and test modes and a lock detect output.

### Main Counter Chain

#### Normal Operating Mode

Setting the PB control bit “low” enables the ÷10/11 prescaler. The main counter chain then divides the RF input frequency ( $F_{IN}$ ) by an integer derived from the values in the “M” and “A” counters.

In this mode, the output from the main counter chain ( $f_p$ ) is related to the VCO frequency ( $F_{IN}$ ) by the following equation:

$$f_p = F_{IN} / [10 \times (M + 1) + A] \quad (1)$$

where  $A \leq M + 1$ ,  $1 \leq M \leq 511$

When the loop is locked,  $F_{IN}$  is related to the reference frequency ( $F_R$ ) by the following equation:

$$F_{IN} = [10 \times (M + 1) + A] \times (F_R / (R+1)) \quad (2)$$

where  $A \leq M + 1$ ,  $1 \leq M \leq 511$

A consequence of the upper limit on A is that  $F_{IN}$  must be greater than or equal to  $90 \times (F_R / (R+1))$  to obtain contiguous channels. The A counter can accept values as high as 15, but in typical operation it will cycle from 0 to 9 between increments in M.

Programming the M counter with the minimum allowed value of “1” will result in a minimum M counter divide ratio of “2”.

#### Prescaler Bypass Mode

Setting the enhancement register bit PB “high” allows  $F_{IN}$  to bypass the ÷10/11 prescaler. In this mode, the prescaler and A counter are powered down, and the input VCO frequency is divided by the M counter directly. This mode is only available when using the serial port to set the frequency control bits. The following equation relates  $F_{IN}$  to the reference frequency  $F_R$ :

$$F_{IN} = (M + 1) \times (F_R / (R+1)) \quad (3)$$

where  $1 \leq M \leq 511$

### Reference Counter

The reference counter chain divides the reference frequency  $F_R$  down to the phase detector comparison frequency  $f_c$ .

The output frequency of the 6-bit R Counter is related to the reference frequency by the following equation:

$$f_c = F_R / (R + 1) \quad (4)$$

where  $0 \leq R \leq 63$

Note that programming R with “0” will pass the reference frequency ( $F_R$ ) directly to the phase detector.

## Register Programming

### Serial Interface Mode

Serial Interface Mode is selected by setting the  $D_{MODE}$  input “low”.

While the  $E\_WR$  input is “low”, serial data (DATA input),  $B_0$  to  $B_{19}$ , is clocked into a buffer register on the rising edge of CLOCK, LSB ( $B_0$ ) first. The contents from this buffer register are transferred into the frequency control register on the rising edge of  $S\_WR$  according to the timing diagram shown in *Figure 9*. This data controls the counters as shown in *Table 7*.

While the  $E\_WR$  input is “high”, serial data (DATA input),  $B_0$  to  $B_7$ , is clocked into a buffer register on the rising edge of CLOCK, LSB ( $B_0$ ) first. The contents from this buffer register are transferred into the enhancement register on the falling edge of  $E\_WR$  according to the timing diagram shown

in *Figure 9*. After the falling edge of  $E\_WR$ , the data provides control bits as shown in *Table 8*. These bits are active when the  $ENH$  input is “low”.

### Direct Interface Mode

Direct Interface Mode is selected by setting the  $D_{MODE}$  input “high”. In this mode, the counter values are set directly at external pins as shown in *Table 7* and *Figure 2*. All frequency control register bits are addressable except PB (it is not possible to bypass the  $\div 10/11$  dual modulus prescaler in Direct Mode).

**Table 7. Frequency Register Programming**

Interface Mode	ENH	$D_{MODE}$	$R_5$	$R_4$	$M_8$	$M_7$	X	$M_6$	$M_5$	$M_4$	$M_3$	$M_2$	$M_1$	$M_0$	$R_3$	$R_2$	$R_1$	$R_0$	$A_3$	$A_2$	$A_1$	$A_0$
Serial*	1	0	$B_0$	$B_1$	$B_2$	$B_3$	$B_4$	$B_5$	$B_6$	$B_7$	$B_8$	$B_9$	$B_{10}$	$B_{11}$	$B_{12}$	$B_{13}$	$B_{14}$	$B_{15}$	$B_{16}$	$B_{17}$	$B_{18}$	$B_{19}$
Direct	1	1	$R_5$	$R_4$	$M_8$	$M_7$	0	$M_6$	$M_5$	$M_4$	$M_3$	$M_2$	$M_1$	$M_0$	$R_3$	$R_2$	$R_1$	$R_0$	$A_3$	$A_2$	$A_1$	$A_0$

\* Data is clocked serially on CLOCK rising edge while  $E\_WR$  is “low” and transferred to frequency register on  $S\_WR$  rising edge.

↑  
MSB (first in)

(last in) LSB ↑

**Table 8. Enhancement Register Programming**

Interface Mode	ENH	$D_{MODE}$	Reserved*	Reserved*	fp output	Power down	Counter load	MSEL output	fc output	PB
Serial**	0	X	$B_0$	$B_1$	$B_2$	$B_3$	$B_4$	$B_5$	$B_6$	$B_7$

\* Program to 0

\* Data is clocked serially on CLOCK rising edge while  $E\_WR$  is “low” and transferred to frequency register on  $S\_WR$  rising edge.

↑  
MSB (first in)

(last in) LSB ↑

Figure 9. Serial Interface Mode Timing Diagram

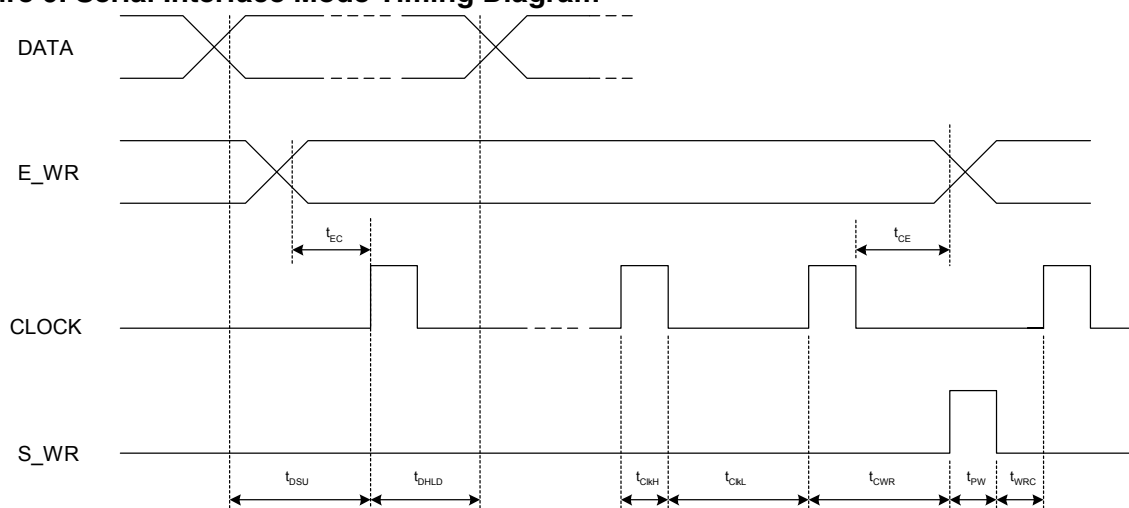

### Enhancement Register

The functions of the enhancement register bits are shown below. All bits are active high. Operation is undefined if more than one output is sent to D<sub>OUT</sub>.

Table 9. Enhancement Register Bit Functionality

Bit	Function	Description
Bit 0	Reserved <sup>1</sup>	
Bit 1	Reserved <sup>1</sup>	
Bit 2	f <sub>p</sub> output	Drives the M counter output onto the D <sub>OUT</sub> output.
Bit 3	Power down	Power down of all functions except programming interface.
Bit 4	Counter load	Immediate and continuous load of counter programming.
Bit 5	MSEL output	Drives the internal dual modulus prescaler modulus select (MSEL) onto the D <sub>OUT</sub> output.
Bit 6	f <sub>c</sub> output	Drives the R counter output onto the D <sub>OUT</sub> output
Bit 7	PB	Allows Fin to bypass the 10/11 prescaler

Note: 1. Program to 0

### Phase Detector Outputs

The phase detector is triggered by rising edges from the main counter (f<sub>p</sub>) and the reference counter (f<sub>c</sub>). It has two outputs, PD<sub>U</sub> and PD<sub>D</sub>. If the divided VCO leads the divided reference in phase or frequency (f<sub>p</sub> leads f<sub>c</sub>), PD<sub>D</sub> pulses “low”. If the divided reference leads the divided VCO in phase or frequency (f<sub>c</sub> leads f<sub>p</sub>), PD<sub>U</sub> pulses “low”. The width of either pulse is directly proportional to phase offset between the two input signals, f<sub>p</sub> and f<sub>c</sub>. The phase detector gain is 430 mV/radian.

PD<sub>U</sub> and PD<sub>D</sub> are designed to drive an active loop filter which controls the VCO tune voltage. PD<sub>U</sub> pulses result in an increase in VCO frequency and PD<sub>D</sub> results in a decrease in VCO frequency.

Software tools for designing the active loop filter can be found at Peregrine’s web site: [www.psemi.com](http://www.psemi.com).

### Lock Detect Output

A lock detect signal is provided at pin LD, via the pin C<sub>EXT</sub> (see Figure 1). C<sub>EXT</sub> is the logical “NAND” of PD<sub>U</sub> and PD<sub>D</sub> waveforms, driven through a series 2 kΩ resistor. Connecting C<sub>EXT</sub> to an external shunt capacitor provides integration of this signal.

The C<sub>EXT</sub> signal is then sent to the LD pin through an internal inverting comparator with an open drain output. Thus LD is an “AND” function of PD<sub>U</sub> and PD<sub>D</sub>.

**Figure 10. Package Drawing**  
44-lead CQFJ

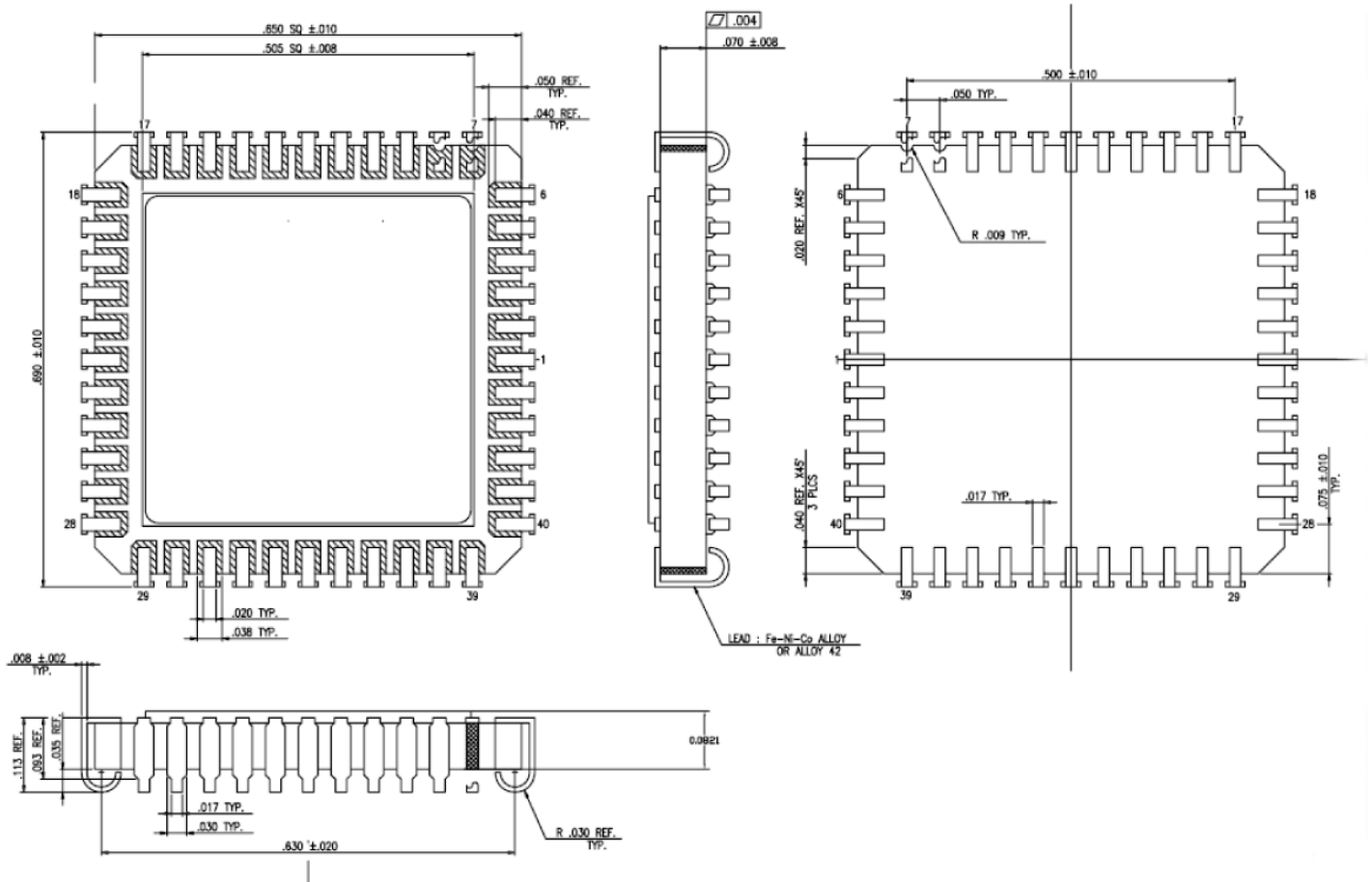

All dimensions are in inches

**Table 10. Ordering Information**

Order Code	Part Marking	Description	Package	Shipping Method
97042-01	PE97042 ES	Engineering Samples	44-pin CQFJ	40 units / Tray
97042-11	PE97042	Flight Units	44-pin CQFJ	40 units / Tray
97042-99	FA97042	Die Production Units	Die	100 units / Waffle Pack
97042-00	PE97042 EK	Evaluation Kit		1 / Box

**Sales Contact and Information**

For Sales and contact information please visit [www.psemi.com](http://www.psemi.com).

**Advance Information:** The product is in a formative or design stage. The datasheet contains design target specifications for product development. Specifications and features may change in any manner without notice. **Preliminary Specification:** The datasheet contains preliminary data. Additional data may be added at a later date. Peregrine reserves the right to change specifications at any time without notice in order to supply the best possible product. **Product Specification:** The datasheet contains final data. In the event Peregrine decides to change the specifications, Peregrine will notify customers of the intended changes by issuing a CNF (Customer Notification Form).

The information in this datasheet is believed to be reliable. However, Peregrine assumes no liability for the use of this information. Use shall be entirely at the user's own risk.

No patent rights or licenses to any circuits described in this datasheet are implied or granted to any third party.

Peregrine's products are not designed or intended for use in devices or systems intended for surgical implant, or in other applications intended to support or sustain life, or in any application in which the failure of the Peregrine product could create a situation in which personal injury or death might occur. Peregrine assumes no liability for damages, including consequential or incidental damages, arising out of the use of its products in such applications.

The Peregrine name, logo, and UTSi are registered trademarks and UltraCMOS, HaRP, MultiSwitch and DuNE are trademarks of Peregrine Semiconductor Corp.