

SP6T UltraCMOS™ 2.6 V Switch 100 – 3000 MHz

Figure 1. Functional Diagram

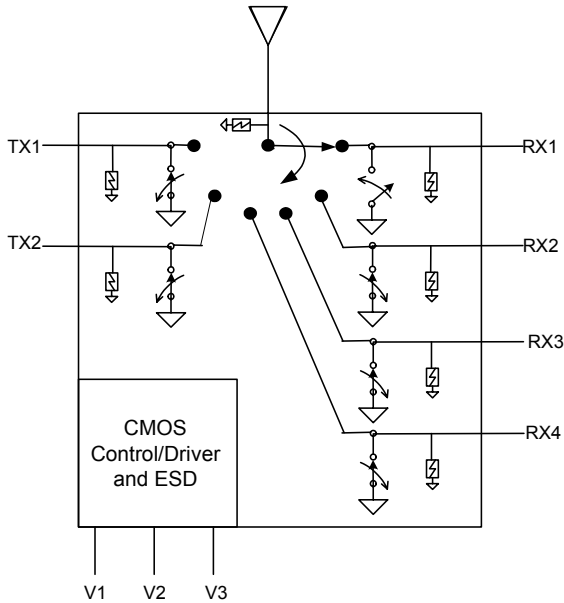
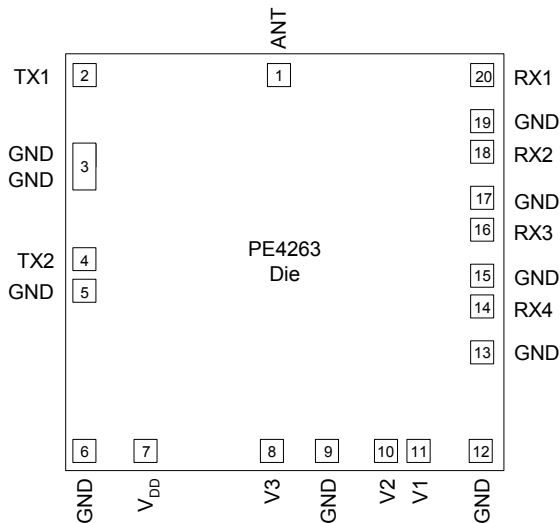

Figure 2. Pin Configuration (Top View)



Features

- Three pin CMOS logic control with integral decoder/driver
- Low TX insertion loss: 0.55 dB at 900 MHz, 0.65 dB at 1900 MHz
- TX – RX Isolation of 48 dB at 900 MHz, 40 dB at 1900 MHz
- Low harmonics: $2f_o = -85$ dBc and $3f_o = -72$ dBc at 850/900 MHz
- 1500 V HBM ESD tolerance all ports
- 41 dBm P1dB
- No blocking capacitors required

Product Description

The PE4263 SP6T RF UltraCMOS™ Switch addresses the specific design needs of the Quad-Band GSM Handset Antenna Switch Module Market. On-chip CMOS decode logic facilitates three-pin low voltage CMOS control. High ESD tolerance of 1500 V at all ports, no blocking capacitor requirements and on-chip SAW filter over-voltage protection devices make this the ultimate in integration and ruggedness.

The PE4263 RF Switch is manufactured on Peregrine's UltraCMOS™ process, a patented variation of silicon-on-insulator (SOI) technology on a sapphire substrate, offering the performance of GaAs with the economy and integration of conventional CMOS.

Figure 3. Die Top View

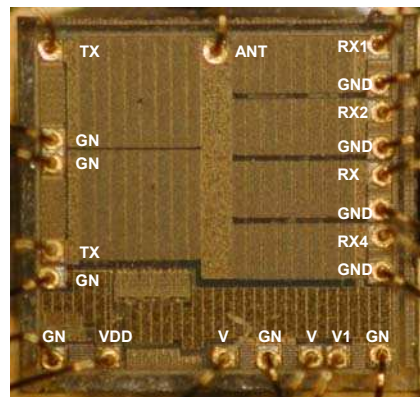

Table 1. Electrical Specifications @ +25 °C, V_{DD} = 2.6 V (Z_S = Z_L = 50 Ω)

Parameter	Conditions	Typical	Units
Operational Frequency		100-3000	MHz
Insertion Loss	ANT - TX - 850 / 900 MHz	0.55	dB
	ANT - TX - 1800 / 1900 MHz	0.65	dB
	ANT - RX - 850 / 900 MHz	0.90	dB
	ANT - RX - 1800 / 1900 MHz	1.00	dB
Isolation	TX - RX - 850 / 900 MHz	48	dB
	TX - RX - 1800 / 1900 MHz	40	dB
	TX - TX - 850 / 900 MHz	29	dB
	TX - TX - 1800 / 1900 MHz	25	dB
	ANT - TX - 850 / 900 MHz	31	dB
	ANT - TX - 1800 / 1900 MHz	25	dB
Return Loss	850 / 900 MHz	22	dB
	1800 / 1900 MHz	23	
2nd Harmonic	35 dBm TX Input - 850 / 900 MHz	-85	dBc
	33 dBm TX Input - 1800 / 1900 MHz	-81	
3rd Harmonic	35 dBm TX Input - 850 / 900 MHz	-72	dBc
	33 dBm TX Input - 1800 / 1900 MHz	-66	
Switching Time	(10-90%) (90-10%) RF	2	μs

Sales Offices

The Americas

Peregrine Semiconductor Corporation

9380 Carroll Park Drive
 San Diego, CA 92121
 Tel: 858-731-9400
 Fax: 858-731-9499

Europe

Peregrine Semiconductor Europe

Bâtiment Maine
 13-15 rue des Quatre Vents
 F-92380 Garches, France
 Tel: +33-1-4741-9173
 Fax : +33-1-4741-9173

Space and Defense Products

Americas:

Tel: 858-731-9453

Europe, Asia Pacific:

180 Rue Jean de Guiramand
 13852 Aix-En-Provence Cedex 3, France
 Tel: +33-4-4239-3361
 Fax: +33-4-4239-7227

North Asia Pacific

Peregrine Semiconductor K.K.

Teikoku Hotel Tower 10B-6
 1-1-1 Uchisaiwai-cho, Chiyoda-ku
 Tokyo 100-0011 Japan
 Tel: +81-3-3502-5211
 Fax: +81-3-3502-5213

Peregrine Semiconductor, Korea

#B-2402, Kolon Tripolis, #210
 Geumgok-dong, Bundang-gu, Seongnam-si
 Gyeonggi-do, 463-480 S. Korea
 Tel: +82-31-728-4300
 Fax: +82-31-728-4305

South Asia Pacific

Peregrine Semiconductor, China

Shanghai, 200040, P.R. China
 Tel: +86-21-5836-8276
 Fax: +86-21-5836-7652

For a list of representatives in your area, please refer to our Web site at: www.psemi.com