

PE42551

SPDT UltraCMOS™ RF Switch
9 kHz- 6000 MHz

Product Description

The PE42551 RF Switch is designed to support the requirements of the test equipment and ATE market. This broadband general purpose switch maintains excellent RF performance and linearity from 9 kHz through 6000 MHz. The PE42551 integrates on-board CMOS control logic driven by a single-pin, low voltage CMOS control input. It also has a logic select pin which enables changing the logic definition of the control pin. Additional features include a novel user defined logic table, enabled by the on-board CMOS circuitry. The PE42551 also exhibits outstanding isolation that approaches 21 dB at 6000 MHz and is offered in a small 4x4x0.85 mm QFN package.

The PE42551 is manufactured on Peregrine's UltraCMOS™ process, a patented variation of silicon-on-insulator (SOI) technology on a sapphire substrate, offering the performance of GaAs with the economy and integration of conventional CMOS.

Features

- HaRP™-Technology –Enhanced
 - Eliminates Gate and Phase Lag
 - No insertion loss nor phase drift
 - Fast settling time
- High linearity 50 dBm IIP3
- Low insertion loss: 0.65 dB at 3000 MHz, 0.90 dB at 6000 MHz
- High isolation of 29 dB at 3000 MHz, 21 dB at 6000 MHz
- High power 1 dB compression point of +34 dBm
- ESD: 500 V HBM
- Single-pin 2.75 V CMOS logic control
- Logic select pin to change definition of logic control
- Reflective switch design
- 20-lead 4x4x0.85 mm QFN package

Figure 1. Functional Diagram

Peregrine Specification 71-0065

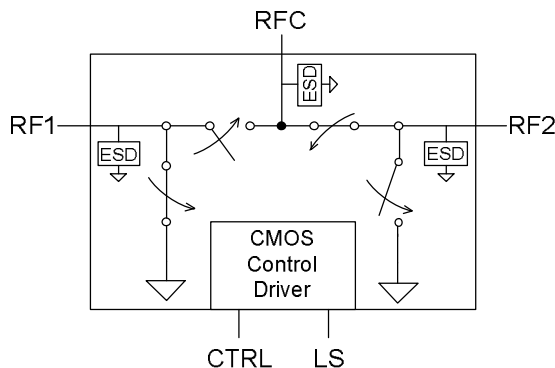

Figure 2. Package Type

20-lead 4x4x0.85 mm QFN

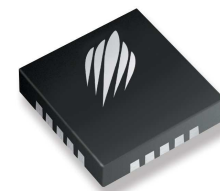

Table 1. Electrical Specifications @ +25 °C, V_{DD} = 2.75 V (Z_s = Z_L = 50 Ω)

| Parameter | Conditions | Min | Typical | Max | Units |
|---------------------------------|--------------------------------|-------|---------|------|-------|
| Operation Frequency | | 9 kHz | | 6000 | MHz |
| Insertion Loss | 9 kHz | | 0.55 | 0.65 | dB |
| | 3000 MHz | | 0.65 | 0.75 | dB |
| | 6000 MHz | | 0.90 | | dB |
| Isolation – RF1 to RF2 | 3000 MHz | 28 | 29 | | dB |
| | 6000 MHz | | 21 | | dB |
| Return Loss RF1, RF2 and RFC | 3000 MHz | 14 | 18 | | dB |
| | 6000 MHz | | 14 | | dB |
| Switching Time | 50% CTRL to 0.1 dB final value | | 7 | | μs |
| Input 1 dB Compression | 6000 MHz | 32 | 34 | | dBm |
| Input IP3 | 6000 MHz | | +50 | | dBm |

Notes:1. Device linearity will begin to degrade below 10 MHz.

Figure 3. Pin Configuration (Top View)

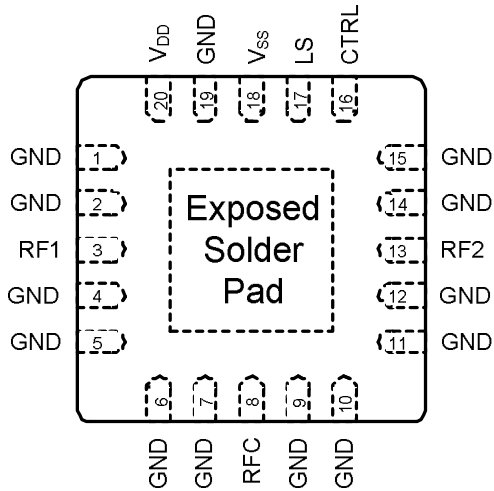

Table 2. Pin Descriptions

| Pin No. | Pin Name | Description |
|---|-----------------|--|
| 13 | RF2 | RF2 port. ¹ |
| 1, 2, 4, 5, 6, 7, 9, 10, 11, 12, 14, 15, 19 | GND | Ground Connection. Traces should be physically short and connected to the ground plane. This pin is connected to the exposed solder pad that also must be soldered to the ground plane for best performance. |
| 3 | RF1 | RF1 port. ¹ |
| 16 | CTRL | CMOS level (See Table 5) |
| 8 | RFC | Common RF port for switch ¹ |
| 17 | LS | Logic Select - Used to determine the definition for the CTRL pin (see Table 5) |
| 18 | V _{SS} | Negative power supply. Apply nominal -2.75 V supply ² |
| 20 | V _{DD} | Nominal 2.75 V supply connection |
| Paddle | GND | Exposed Ground Paddle |

- Notes: 1. All RF pins must be held at 0 VDC or the DC must be blocked with an external series capacitor
 2. Use V_{SS} (pin 13, V_{SS} = -V_{DD}) to bypass and disable internal negative voltage generator. Connect V_{SS} (pin 13) to GND (V_{SS} = 0V) to enable internal negative voltage generator.

Table 3. Absolute Maximum Ratings

| Symbol | Parameter/Conditions | Min | Max | Units |
|-------------------|---|------|----------------------|-------------------|
| V _{DD} | Power supply voltage | -0.3 | 4.0 | V |
| V _I | Voltage on any input except for CTRL and LS inputs | -0.3 | V _{DD} +0.3 | V |
| V _{CTRL} | Voltage on CTRL input | | 4.0 | V |
| V _{LS} | Voltage on LS input | | 4.0 | V |
| T _{ST} | Storage temperature range | -65 | 150 | °C |
| T _{OP} | Operating temperature range | -40 | 85 | °C |
| P _{IN} | Input Power 50Ω: 9 kHz ≤ 600 kHz 600 kHz ≤ 3 MHz 3 MHz ≤ 6 GHz | | 13 20 31 | dBm dBm dBm |
| V _{ESD} | ESD voltage HBM ¹ | | 500 | V |

Note: 1. Human Body Model (HBM, MIL_STD 883 Method 3015.7)

Exceeding absolute maximum ratings may cause permanent damage. Operation should be restricted to the limits in the Operating Ranges table. Operation between operating range maximum and absolute maximum for extended periods may reduce reliability.

Electrostatic Discharge (ESD) Precautions

When handling this UltraCMOS™ device, observe the same precautions that you would use with other ESD-sensitive devices. Although this device contains circuitry to protect it from damage due to ESD, precautions should be taken to avoid exceeding the rating specified.

Moisture Sensitivity Level

The Moisture Sensitivity Level rating for the PE42551 in the 20-lead 4x4x0.85 mm QFN package is MSL1.

Latch-Up Avoidance

Unlike conventional CMOS devices, UltraCMOS™ devices are immune to latch-up.

Table 4. Operating Specifications

| Parameter | Min | Typ | Max | Units |
|--|---------------------|-------|---------------------|-------|
| V _{DD} Positive Power Supply Voltage | 2.5 | 2.75 | 3.0 | V |
| V _{DD} Negative Power Supply Voltage | -2.5 | -2.75 | -3.0 | V |
| I _{DD} Power Supply Current (V _{DD} = 3V, V _{GNL} = 3V) | | 20 | | μA |
| Control Voltage High | 0.7xV _{DD} | | | V |
| Control Voltage Low | | | 0.3xV _{DD} | V |
| RF Power In 50Ω: | | | | |
| 9 kHz ≤ 600 kHz | | | 13 | dBm |
| 600 kHz ≤ 3 MHz | | | 20 | dBm |
| 3 MHz ≤ 6 GHz | | | 31 | dBm |

Spurious Performance

The typical spurious performance of the PE42551 is -116 dBm when V_{SS}=0V. If further improvement is desired, the internal negative voltage generator can be disabled by externally applying a negative voltage to the V_{SS} pin such that V_{SS} = -V_{DD}.

Table 5. Control Logic Truth Table

| LS | CTRL | RFC-RF1 | RFC-RF2 |
|----|------|---------|---------|
| 0 | 0 | off | on |
| 0 | 1 | on | off |
| 1 | 0 | on | off |
| 1 | 1 | off | on |

Logic Select (LS)

The Logic Select feature is used to determine the definition for the CTRL pin.

Switching Frequency

The PE42551 has a maximum 25 kHz switching rate when the internal negative voltage generator is used. In the event a customer applies V_{SS} external (-V_{DD}) to Pin 18, the Switching Rate is limited to the reciprocal of the Switching Time in Table 1.

Evaluation Kit

The SPDT Switch Evaluation Kit board was designed to ease customer evaluation of the PE42551 SPDT switch. The RF common port is connected through a 50 Ω transmission line to J2. Port 1 and Port 2 are connected through 50 Ω transmission lines to J1 and J3. A through transmission line connects SMA connectors J4 and J5. This transmission line can be used to estimate the loss of the PCB over the environmental conditions being evaluated.

The board is constructed of a two metal layer FR4 material with a total thickness of 0.032". The transmission lines were designed using a coplanar waveguide with ground plane (28 mil core, 47.6 mil width, 30 mil gap).

Good RF layout and prudent use of vias is critical for obtaining the specified isolation performance for the device shown in this datasheet.

J6 provides a means for controlling DC and digital inputs to the device. The provided jumpers short the package pin to ground for logic low. When the jumper is removed, the pin is pulled up to V_{DD} for logic high. When the jumper is in place, 3 μA of current will flow through the 1MΩ pull up resistor. This extra current should not be attributed to the requirements of the device.

Figure 4. Evaluation Board Layouts

Peregrine Specification 101-0151

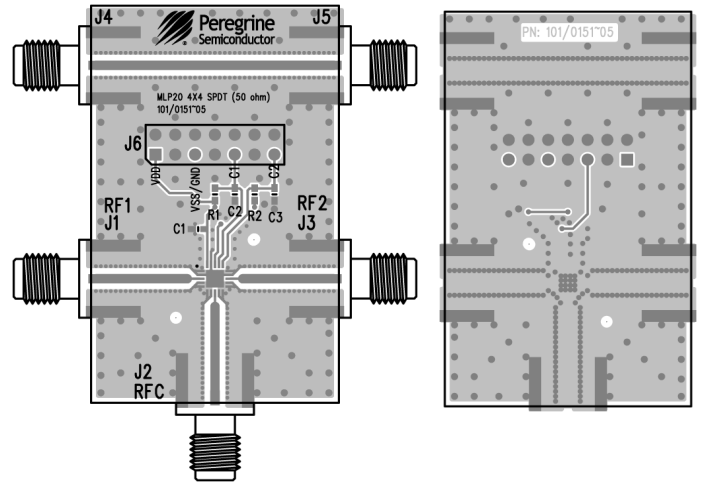
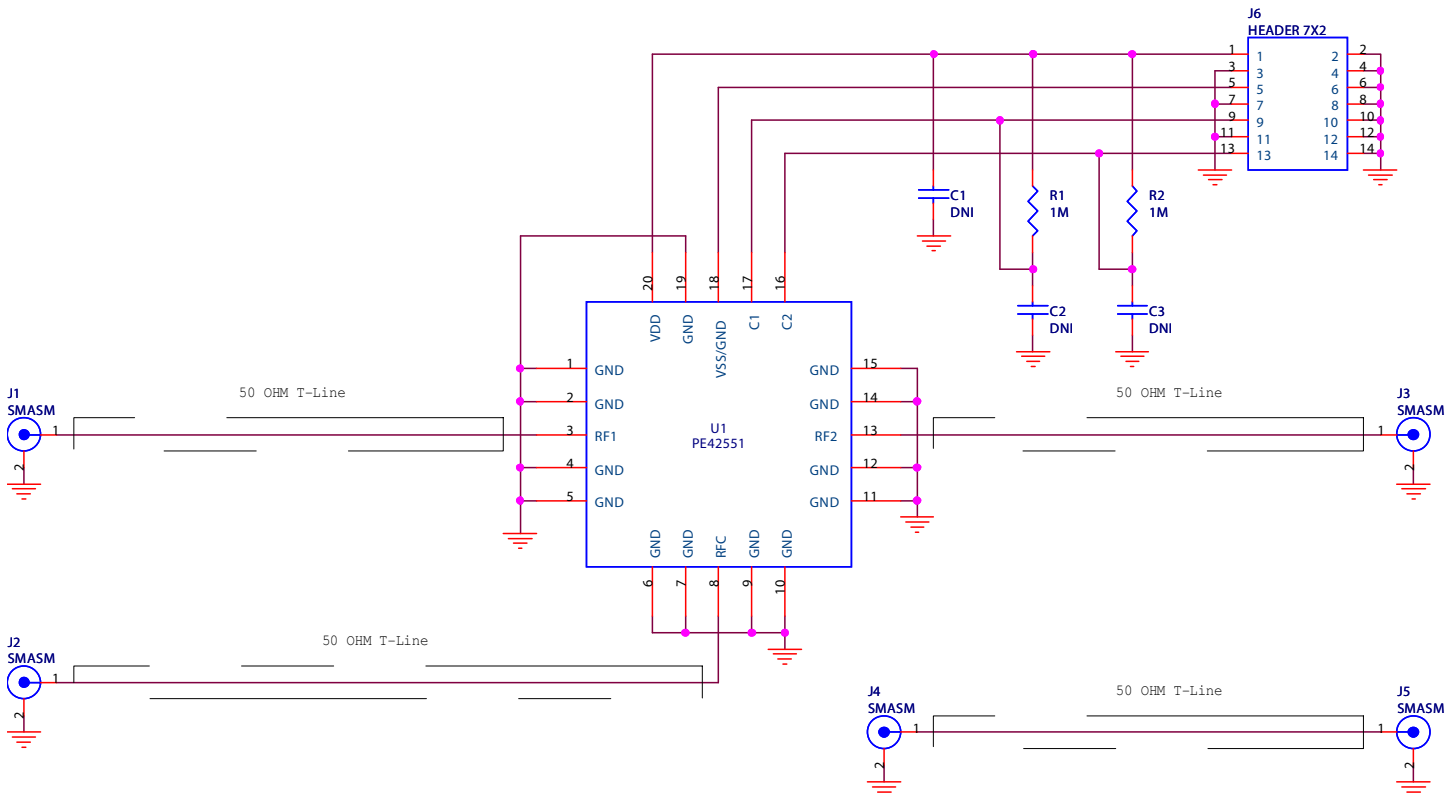

Figure 5. Evaluation Board Schematic

Peregrine Specification 102-0198



Typical Performance Data

Figure 6. Insertion Loss: RFC-RF1@ 25 °C

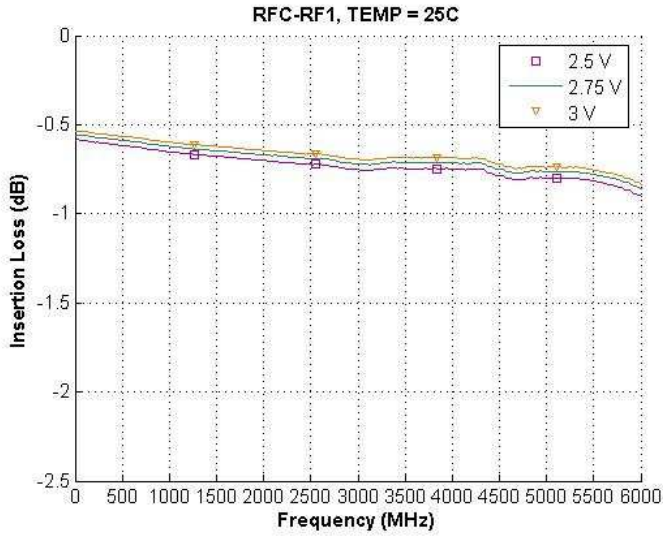

Figure 7. Insertion Loss: RFC-RF1@ 2.75 V

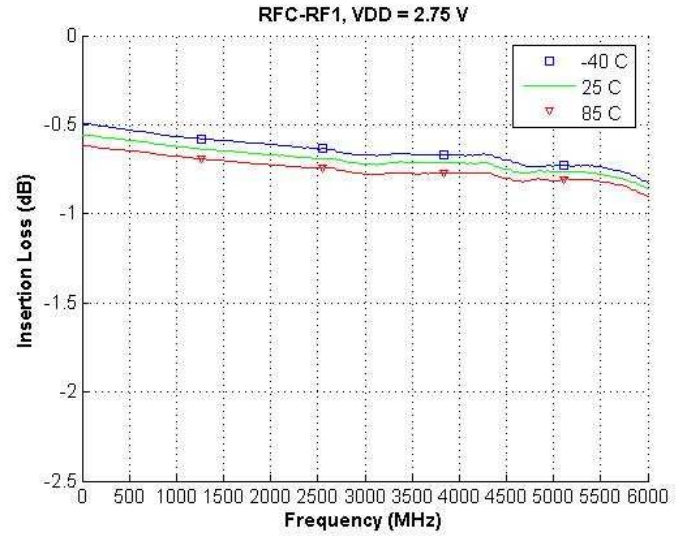

Figure 8. Insertion Loss: RFC-RF2 @ 25 °C

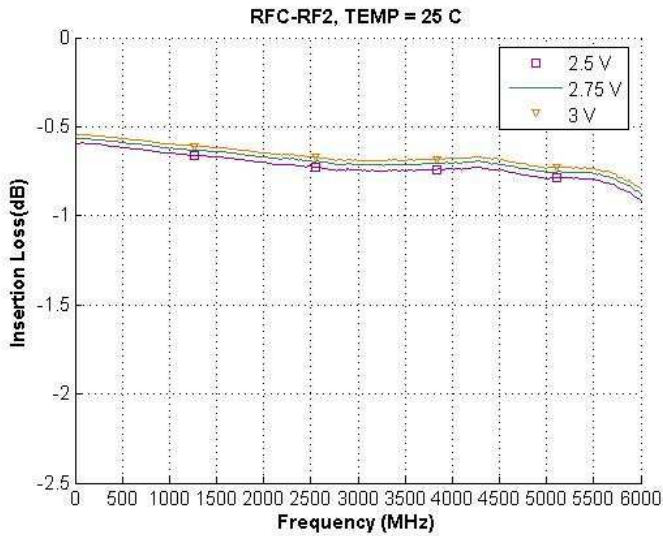
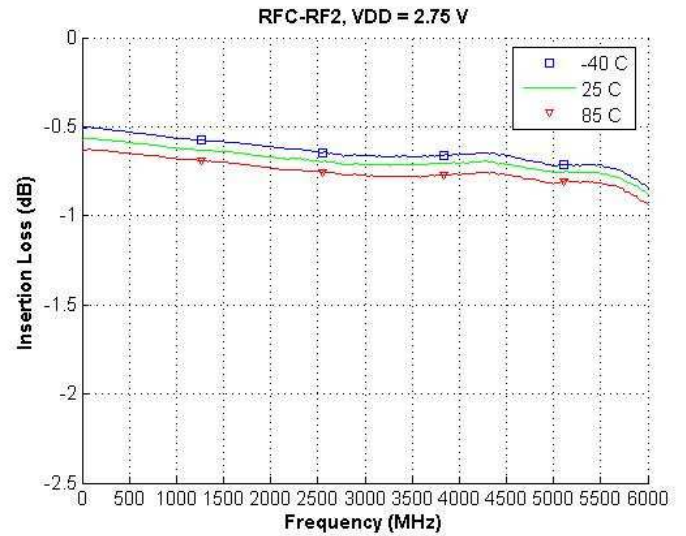

Figure 9. Insertion Loss: RFC-RF2 @ 2.75 V



Typical Performance Data

Figure 10. Isolation: RFC-RF1@ 25 °C

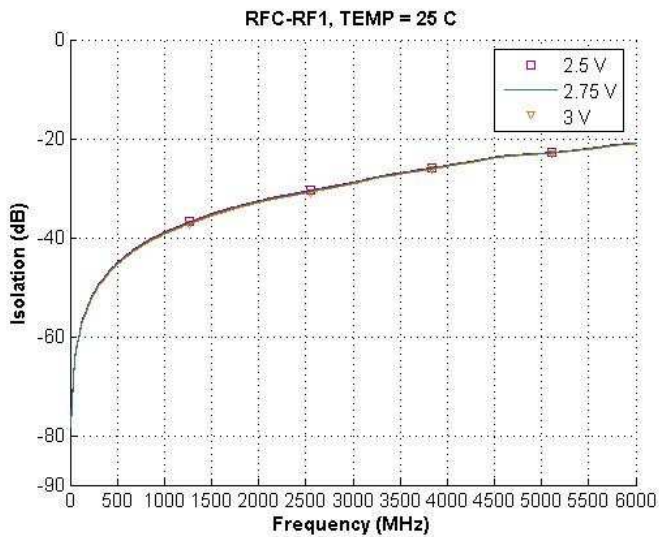

Figure 11. Isolation: RFC-RF1@ 2.75 V

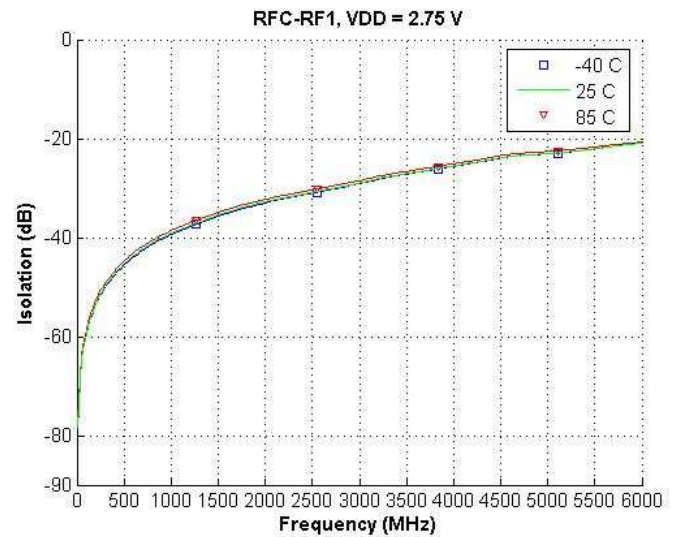

Figure 12. Isolation: RFC-RF2 @ 25 °C

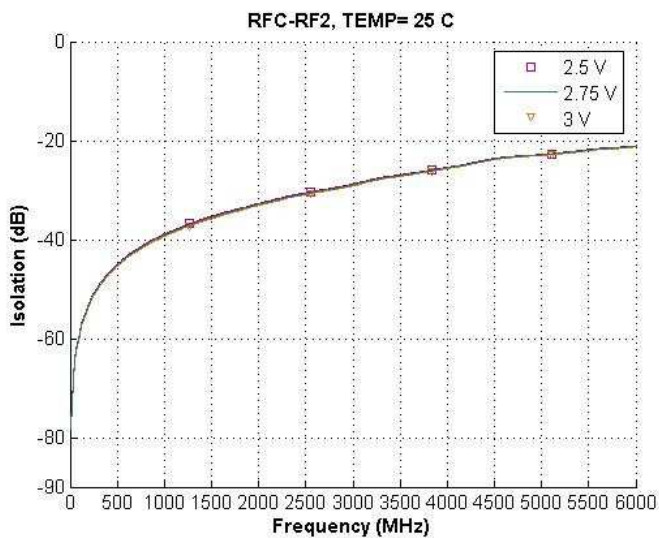
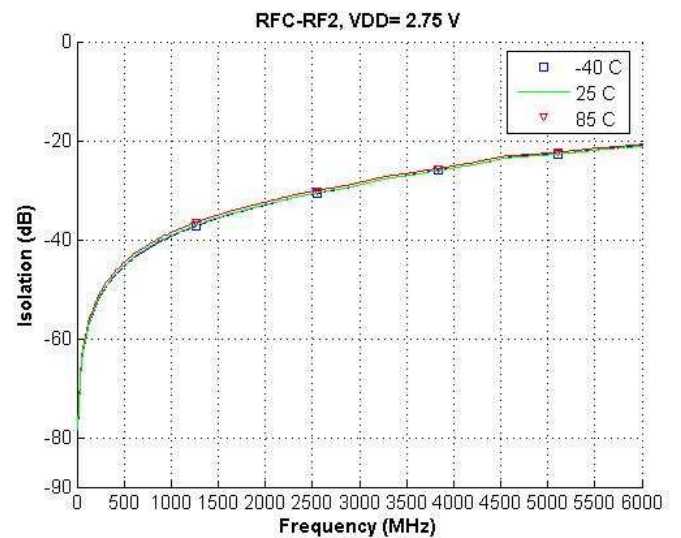

Figure 13. Isolation: RFC-RF2 @ 2.75 V



Typical Performance Data

Figure 14. Return Loss: RF1 @ 25 °C (RFC-RF1 Active Path)

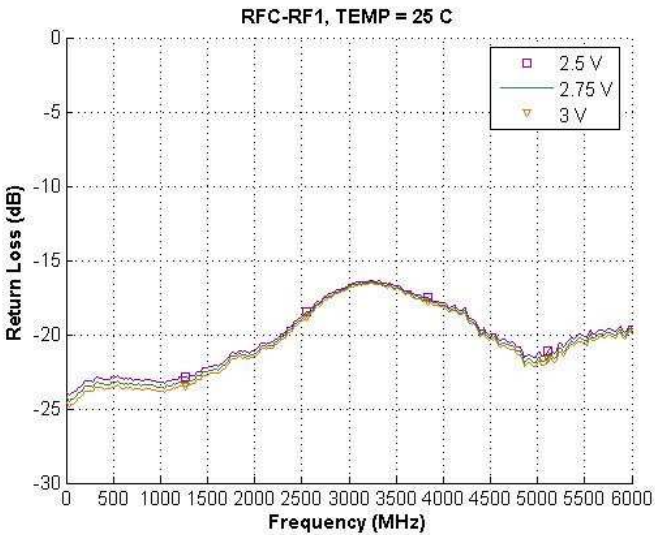

Figure 15. Return Loss: RF1 @ 2.75 V (RFC-RF1 Active Path)

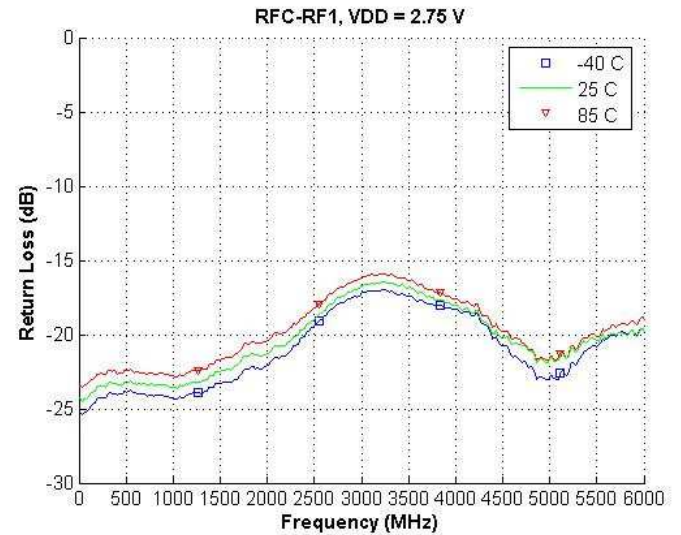

Figure 16. Return Loss: RF2 @ 25 °C (RFC-RF2 Active Path)

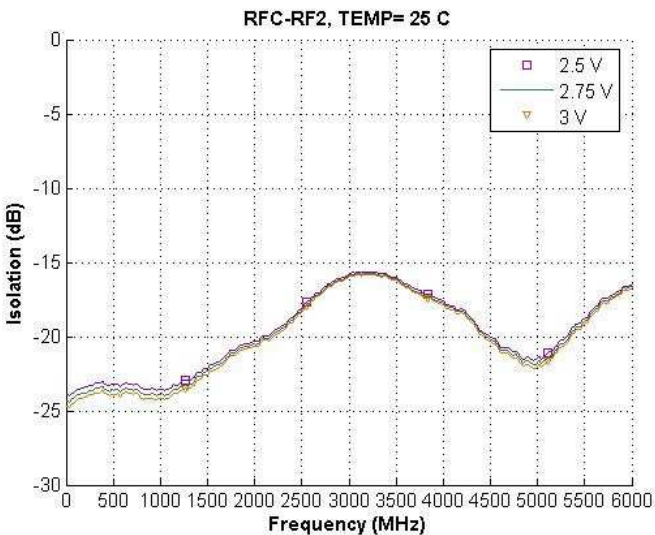

Figure 17. Return Loss: RF2 @ 2.75 V (RFC-RF2 Active Path)

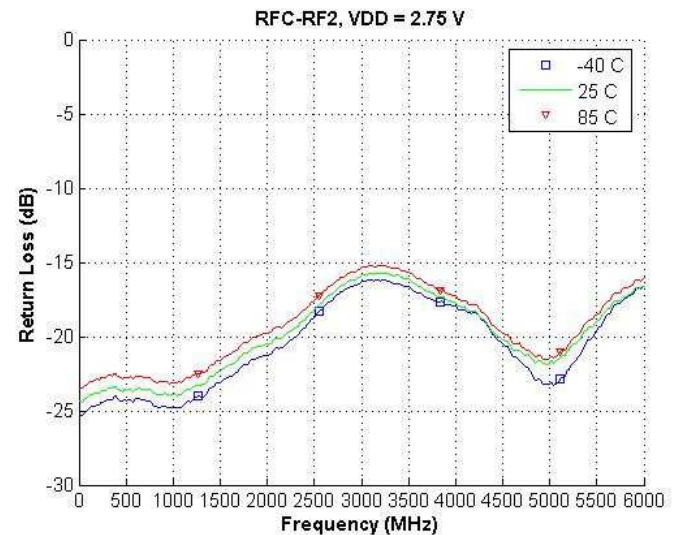

Figure 18. Package Drawing
20-lead 4x4x0.85 mm QFN

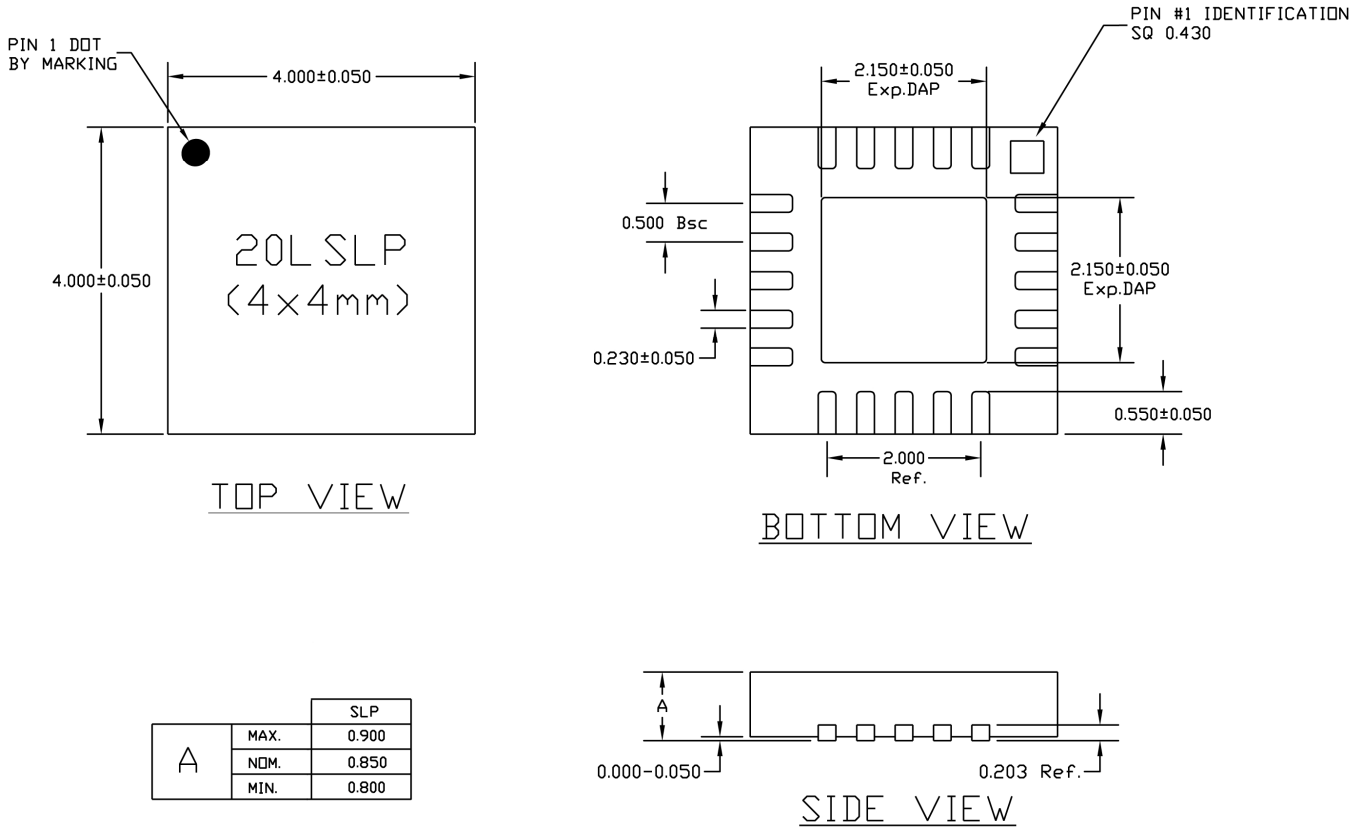
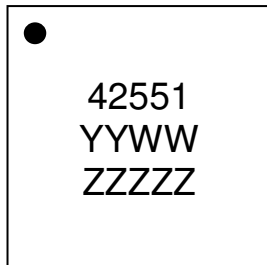
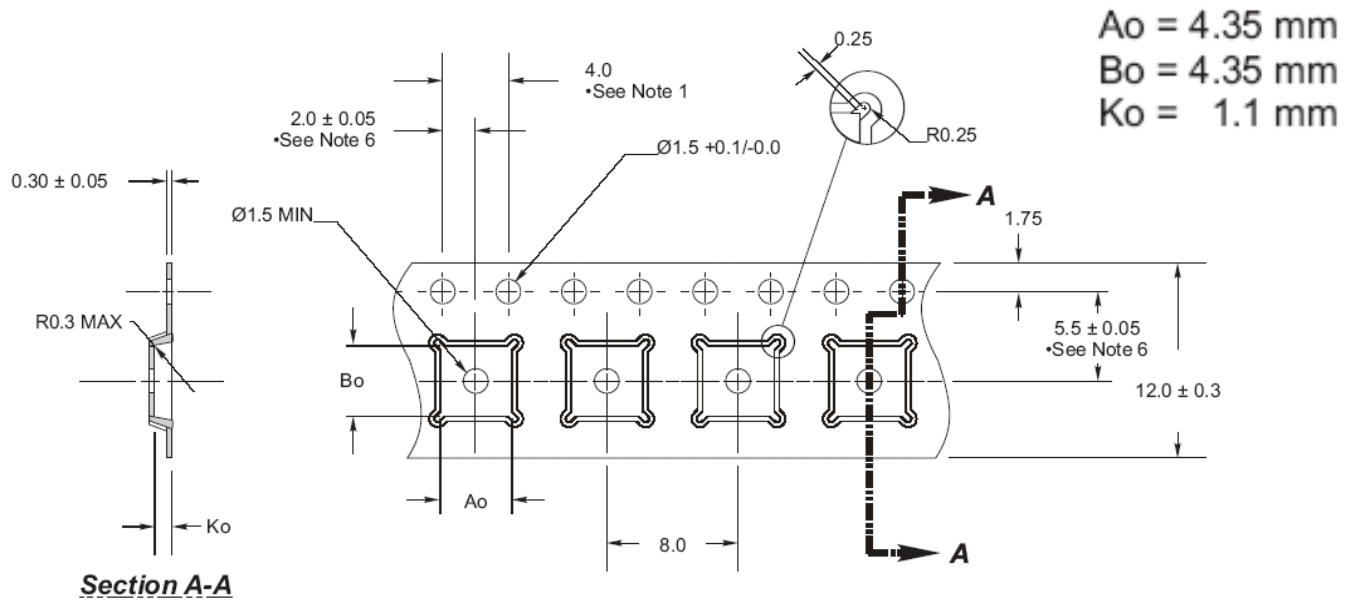

Figure 19. Marking Specifications



YYWW = Date Code
ZZZZZ = Last five digits of Lot Number

Figure 20. Tape and Reel Drawing



Ao = 4.35 mm
Bo = 4.35 mm
Ko = 1.1 mm

Section A-A

Notes:

1. 10 sprocket hole pitch cumulative tolerance ± 0.02 .
2. Camber not to exceed 1mm in 100mm.
3. Material: PS + C.
4. Ao and Bo measured as indicated.
5. Ko measured from a plane on the inside bottom of the pocket to the top surface of the carrier.
6. Pocket position relative to sprocket hole measured as true position of pocket, not pocket hole.

-----> **Tape Feed Direction** ----->

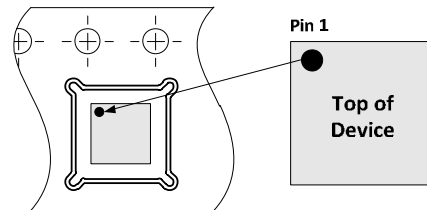

Device Orientation in Tape

Table 6. Ordering Information

| Order Code | Part Marking | Description | Package | Shipping Method |
|------------|--------------|-----------------------------|--------------------------|-----------------|
| 42551-00 | PE42551-EK | PE42551-20QFN 4x4 mm-EK | Evaluation Kit | 1/Box |
| 42551-51 | 42551 | PE42551G-20QFN 4x4 mm | Green 20-lead 4x4 mm QFN | Cut Tape |
| 42551-52 | 42551 | PE42551G-20QFN 4x4 mm-3000C | Green 20-lead 4x4 mm QFN | 3000 units/T&R |

Sales Offices

The Americas

Peregrine Semiconductor Corporation

9380 Carroll Park Drive
San Diego, CA 92121
Tel: 858-731-9400
Fax: 858-731-9499

Europe

Peregrine Semiconductor Europe

Bâtiment Maine
13-15 rue des Quatre Vents
F-92380 Garches, France
Tel: +33-1-4741-9173
Fax : +33-1-4741-9173

High-Reliability and Defense Products

Americas

San Diego, CA, USA
Phone: 858-731-9475
Fax: 848-731-9499

Europe/Asia-Pacific

Parc Cezanne 1
380 Avenue Archimède
Parc de la Duranne
13857 Aix-En-Provence Cedex 3, France
Tel: +33(0)-4-4239-3361
Fax: +33(0)-4-4269-7227

Peregrine Semiconductor, Asia Pacific (APAC)

Shanghai, 200040, P.R. China
Tel: +86-21-5836-8276
Fax: +86-21-5836-7652

Peregrine Semiconductor, Korea

#B-2607, Kolon Tripolis, 210
Geumgok-dong, Bundang-gu, Seongnam-si
Gyeonggi-do, 463-943 South Korea
Tel: +82-31-728-3939
Fax: +82-31-728-3940

Peregrine Semiconductor K.K., Japan

601 Yaesu Kyodo Building
2-5-9 Yaesu, Chuo-ku
Tokyo 104-0028 Japan
Tel: +81-3-3527-9841
Fax: +81-3-3527-9848

For a list of representatives in your area, please refer to our
Web site at: www.psemi.com

Data Sheet Identification

Advance Information

The product is in a formative or design stage. The data sheet contains design target specifications for product development. Specifications and features may change in any manner without notice.

Preliminary Specification

The data sheet contains preliminary data. Additional data may be added at a later date. Peregrine reserves the right to change specifications at any time without notice in order to supply the best possible product.

Product Specification

The data sheet contains final data. In the event Peregrine decides to change the specifications, Peregrine will notify customers of the intended changes by issuing a CNF (Customer Notification Form).

The information in this data sheet is believed to be reliable. However, Peregrine assumes no liability for the use of this information. Use shall be entirely at the user's own risk.

No patent rights or licenses to any circuits described in this data sheet are implied or granted to any third party.

Peregrine's products are not designed or intended for use in devices or systems intended for surgical implant, or in other applications intended to support or sustain life, or in any application in which the failure of the Peregrine product could create a situation in which personal injury or death might occur. Peregrine assumes no liability for damages, including consequential or incidental damages, arising out of the use of its products in such applications.

The Peregrine name, logo, and UTSi are registered trademarks and UltraCMOS, HaRP, MultiSwitch and DuNE are trademarks of Peregrine Semiconductor Corp.