

Product Description

The PE42641 is a HaRP™-enhanced SP4T RF Switch developed on the UltraCMOS® process technology. This switch contains 4 identical WEDGE/CDMA compliant TX paths and can be used in various GSM and WCDMA mobile applications as well as other wireless applications up to 3000 MHz. It is also suitable for antenna band switching and switchable matching networks for cellular and non-cellular mobile applications. It integrates on-board CMOS control logic with a low voltage CMOS-compatible control interface and requires no DC blocking capacitors. This RoHS-compliant part is available in a standard 3 x 3 x 0.75mm QFN package.

Peregrine's HaRP™ technology enhancements deliver high linearity and exceptional harmonics performance. It is an innovative feature of the UltraCMOS® process, providing performance superior to GaAs with the economy and integration of conventional CMOS.

SP4T UltraCMOS® RF Switch
100 MHz – 3.0 GHz

Features

- Symmetric, High-Power SP4T: All ports WEDGE/CDMA-Compliant
- Very Low Insertion Loss: 0.45 dB @ 1000 MHz, 0.6 dB @ 2000 MHz
- HaRP™ - enhanced Technology for Unparalleled Linearity
 - Low harmonics of $2f_0 = -86$ dBc and $3f_0 = -81$ dBc at +35 dBm
 - IMD3 of -110 dBm at WCDMA Band I
 - IIP3 of +68 dBm
- Very high isolation: 35 dB @ 900 MHz, 29 dB @ 1900 MHz
- Exceptionally high ESD tolerance:
 - Class 3 (4.0 kV HBM) on ANT pin
 - Class 2 (2.0 kV HBM) on all pins
- Integrated decoder for 2-pin control
 - Accepts 1.8V and 2.75V levels
- Low 4.5 ohm series ON resistance
- No blocking capacitors required

Figure 1. Functional Diagram

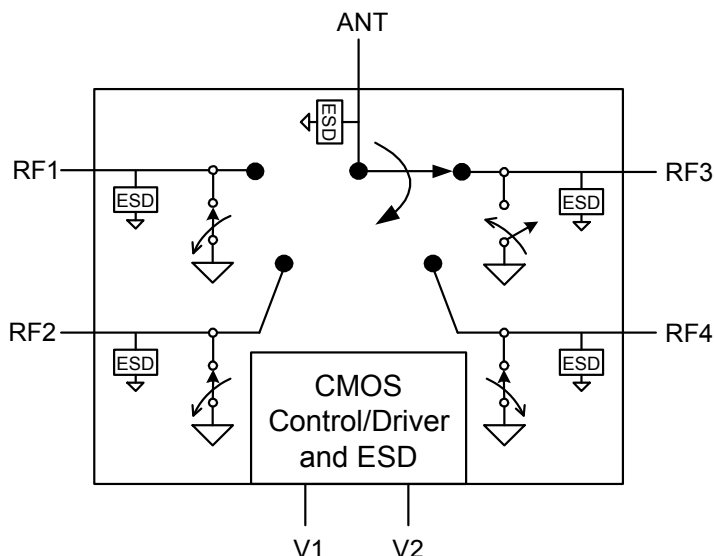

Figure 2. Package Type

16-lead 3x3 mm QFN



Table 1. Electrical Specifications Temp = 25°C, V_{DD} = 2.75V (Z_S = Z_L = 50 Ω)

Parameter	Condition	Min	Typ	Max	Units
Operational Frequency		100		3000	MHz
Insertion Loss ¹ (Symmetric Ports)	ANT - RF (850 / 900 MHz)	-	0.45	0.65	dB
	ANT - RF (1800 / 1900 MHz)	-	0.5	0.7	dB
	ANT - RF (1900 / 2200 MHz)	-	0.55	0.75	dB
Return Loss (Active Ports)	850 / 900 MHz	-	25	-	dB
	1800 / 1900 MHz	-	19	-	dB
	1900 / 2100 MHz	-	18	-	dB
Isolation	RF - ANT (850 / 900 MHz)	31	35	-	dB
	RF - ANT (1800 / 1900 MHz)	25	29	-	dB
	RF - ANT (1900 / 2200 MHz)	23.5	27.5	-	dB
2nd Harmonic	35 dBm output power, 850 / 900 MHz		-86	-80	dBc
	33 dBm output power, 1800 / 1900 MHz		-87	-78	dBc
3rd Harmonic	35 dBm output power, 850 / 900 MHz		-81	-73.5	dBc
	33 dBm output power, 1800 / 1900 MHz		-80	-72.5	dBc
IMD3 distortion at 2.14 GHz	RF Measured at 2.14 GHz at Ant port, input +20 dBm CW signal at 1.95 GHz and -15 dBm CW signal at 1.76 GHz		-110		dBm
Switching time	(10-90%) (90-10%) RF		2	5	μs

Note: 1. The typical ON Resistance value at DC is 4.5 Ω

Table 2. Electrical Specifications, Worst Case Conditions: Temp = 85°C, V_{DD} = 2.65 V (Z_S = Z_L = 50 Ω)

Parameter	Condition	Min	Typ	Max	Units
Insertion loss (2.65V, 85C)	ANT - RF (850 / 900 MHz)	-	0.5	0.7	dB
	ANT - RF (1800 / 1900 MHz)	-	0.55	0.75	dB
	ANT - RF (1900 / 2200 MHz)	-	0.6	0.8	dB
Return Loss (Active Ports) (2.65V, 85C)	850 / 900 MHz	-	25	-	dB
	1800 / 1900 MHz	-	19	-	dB
	1900 / 2100 MHz	-	18	-	dB
Isolation (2.65V, 85C)	RF - ANT (850 / 900 MHz)	30.5	34.5	-	dB
	RF - ANT (1800 / 1900 MHz)	24.5	28.5	-	dB
	RF - ANT (1900 / 2200 MHz)	23	27	-	dB
2nd Harmonic (2.65V, 85C)	35 dBm output power, 850 / 900 MHz		-84	-78	dBc
	33 dBm output power, 1800 / 1900 MHz		-85	-76	dBc
3rd Harmonic (2.65V, 85C)	35 dBm output power, 850 / 900 MHz		-79	-71.5	dBc
	33 dBm output power, 1800 / 1900 MHz		-78	-70.5	dBc
IMD3 distortion at 2.14 GHz (2.65V, 85C)	RF Measured at 2.14 GHz at Ant port, input +20 dBm CW signal at 1.95 GHz and -15 dBm CW signal at 1.76 GHz		-108		dBm
Switching time	(10-90%) (90-10%) RF		2	5	μs

Figure 3. Pin Configuration (Top View)

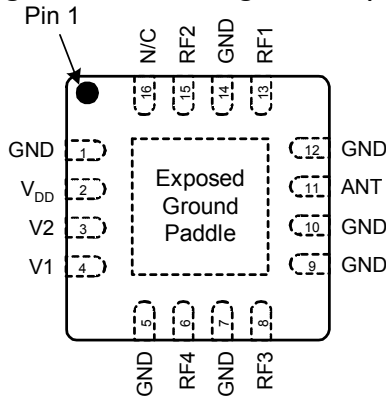

Table 3. Pin Descriptions

Pin No.	Pin Name	Description
1	GND	Ground
2	V _{DD}	Supply
3	V2	Switch control input, CMOS logic level
4	V1	Switch control input, CMOS logic level
5	GND	Ground
6	RF4 ²	RF Port 4
7	GND	Ground
8	RF3 ²	RF Port 3
9	GND	Ground
10	GND	Ground
11	ANT ²	RF Common – Antenna
12	GND	Ground
13	RF1 ²	RF Port 1
14	GND	Ground
15	RF2 ²	RF Port 2
16	N/C	No Connect
Paddle	GND	Ground for proper device operation

Note: 2. Blocking capacitors needed only when non-zero DC voltage present

Table 4. Operating Ranges

Parameter	Symbol	Min	Typ	Max	Units
Temperature range	T _{OP}	-40		+85	°C
V _{DD} Supply Voltage	V _{DD}	2.65	2.75	2.85	V
I _{DD} Power Supply Current (V _{DD} = 2.75V)	I _{DD}		13	50	µA
RF input power ³ (VSWR ≤ 3:1) 824-915 MHz	P _{IN}			+35	dBm
RF input power ³ (VSWR ≤ 3:1) 1710-1910 MHz				+33	
Control Voltage High	V _{IH}	1.4			V
Control Voltage Low	V _{IL}			0.4	V

Note: 3. Assumes RF input period of 4620 µs and duty cycle of 50%

Table 5. Absolute Maximum Ratings

Symbol	Parameter/Conditions	Min	Max	Units
V _{DD}	Power supply voltage	-0.3	4.0	V
V _I	Voltage on any DC input	-0.3	V _{DD} + 0.3	V
T _{ST}	Storage temperature range	-65	+150	°C
P _{IN} (50 Ω)	RF input power (50 Ω) ^{4,5} 824-915 MHz		+38	dBm
	RF input power (50 Ω) ^{4,5} 1710-1910 MHz		+36	
P _{IN} (∞:1)	RF input power (VSWR = ∞:1) ^{4,5} 824-915 MHz		+35	dBm
	RF input power (VSWR = ∞:1) ^{4,5} 1710-1910 MHz		+33	
V _{ESD} ⁶	ESD Voltage, ANT pin		4000	V
	ESD Voltage, all pins		2000	V

Notes: 4. Assumes RF input period of 4620 µs and duty cycle of 50%

5. V_{DD} within operating range specified in Table 4

6. ESD Voltage (HBM, MIL-STD-883 Method 3015.7)

Exceeding absolute maximum ratings may cause permanent damage. Operation should be restricted to the limits in the Operating Ranges table. Operation between operating range maximum and absolute maximum for extended periods may reduce reliability.

Table 6. Truth Table

Path	V2	V1
ANT – RF1	0	0
ANT – RF2	1	0
ANT – RF3	0	1
ANT – RF4	1	1

Electrostatic Discharge (ESD) Precautions

When handling this UltraCMOS[®] device, observe the same precautions that you would use with other ESD-sensitive devices. Although this device contains circuitry to protect it from damage due to ESD, precautions should be taken to avoid exceeding the specified rating.

Latch-Up Avoidance

Unlike conventional CMOS devices, UltraCMOS[®] devices are immune to latch-up.

Moisture Sensitivity Level

The Moisture Sensitivity Level rating for the PE42641 in the 16-lead 3x3 QFN package is MSL1.

Evaluation Kit

The SP4T switch EK Board was designed to ease customer evaluation of Peregrine's PE42641. The RF common port is connected through a 50 Ω transmission line via the top SMA connector, J1. RF1, RF2, RF3 and RF4 are connected through 50 Ω transmission lines via SMA connectors J3, J5, J2 and J4, respectively. A through 50 Ω transmission is available via SMA connectors J6 and J7. This transmission line can be used to estimate the loss of the PCB over the environmental conditions being evaluated.

The board is constructed of a four metal layer FR4 material with a total thickness of 62 mils. The middle layers provide ground for the transmission lines. The transmission lines were designed using a coplanar waveguide with ground plane model using a trace width of 32 mils, trace gaps of 25 mils, and metal thickness of 2.1 mils.

Figure 4. Evaluation Board Layouts
Peregrine Specification 101/0287

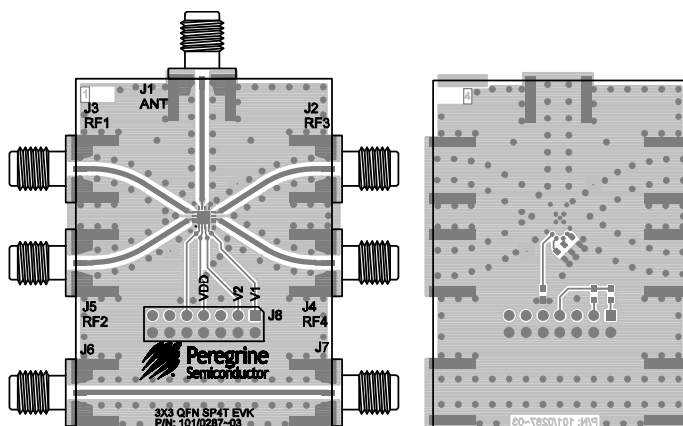

Figure 5. Evaluation Board Schematic
Peregrine Specification 102/0339

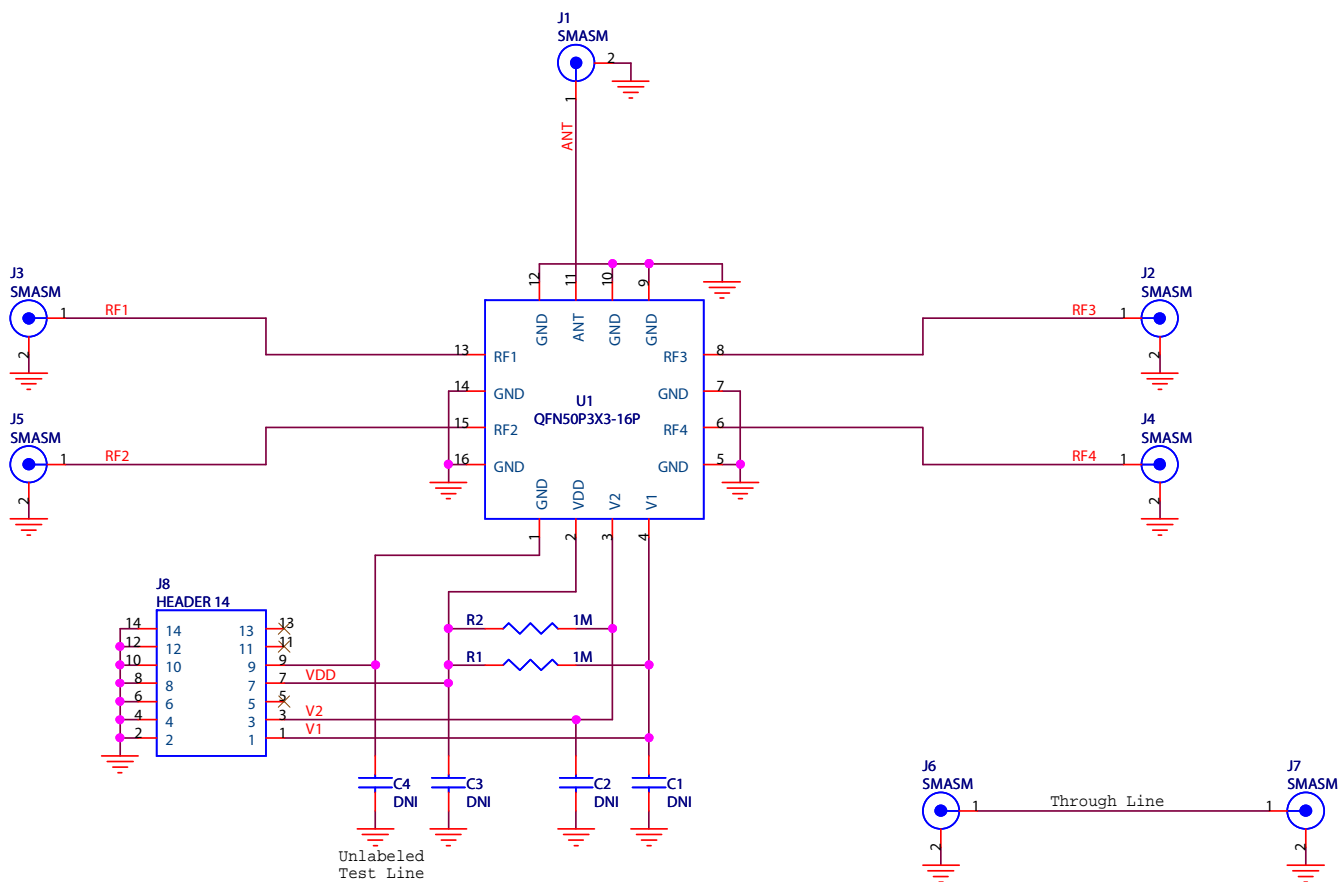

Figure 6. Insertion Loss: ANT-RF @ 25°C

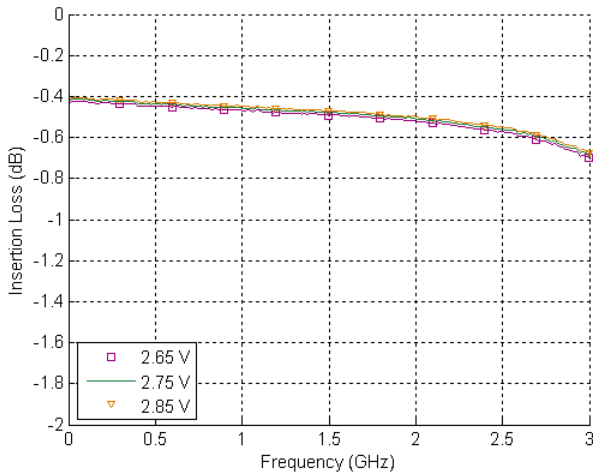

Figure 7. Insertion Loss: ANT-RF @ 2.75V

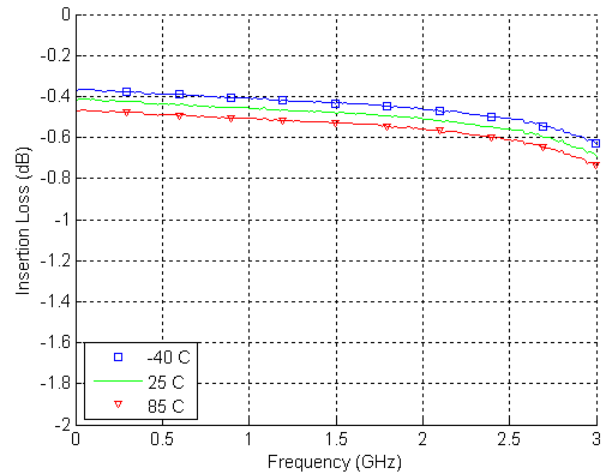

Figure 8. Isolation: ANT-RF @ 25°C

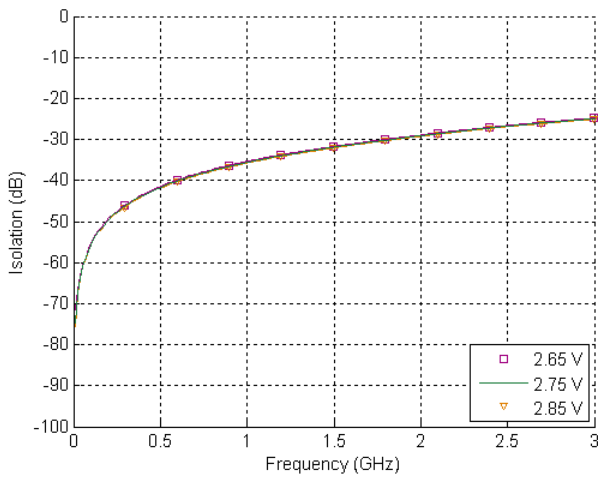

Figure 9. Isolation: ANT-RF @ 2.75V

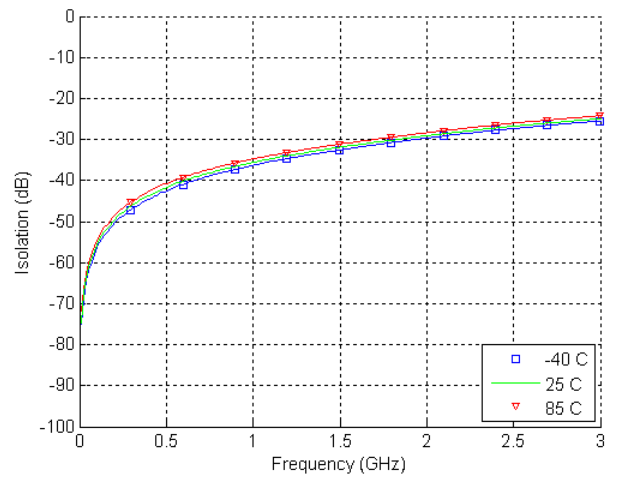

Figure 10. Return Loss at active port @ 25°C

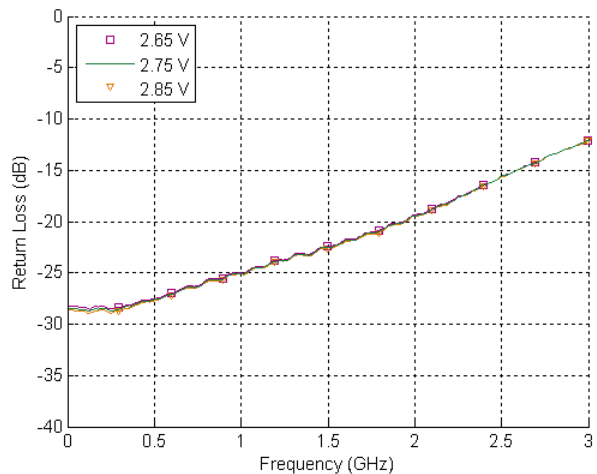

Figure 11. Return Loss at active port @ 2.75V

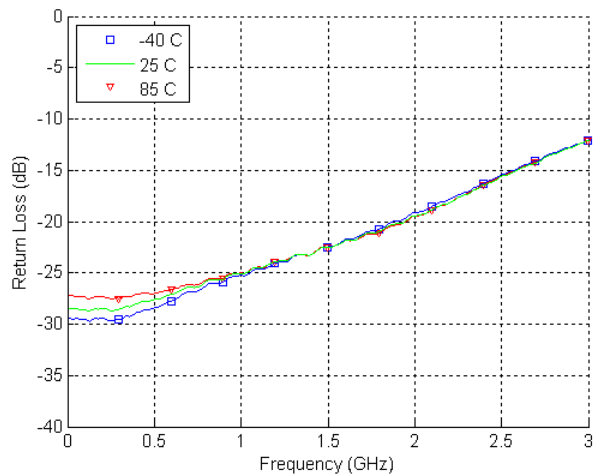
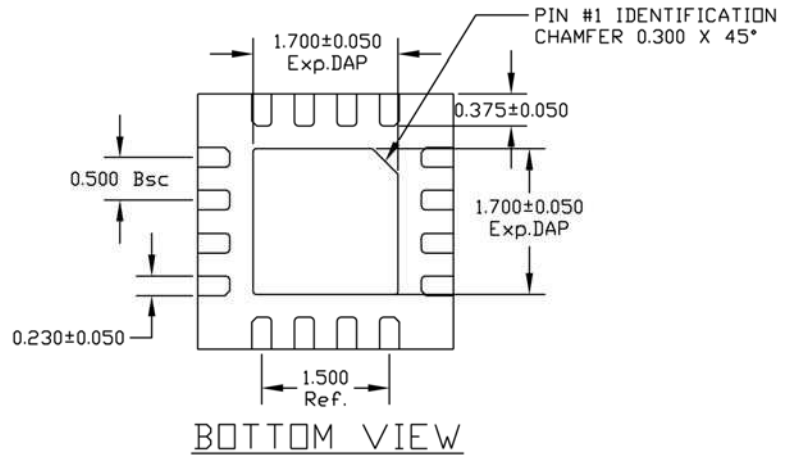
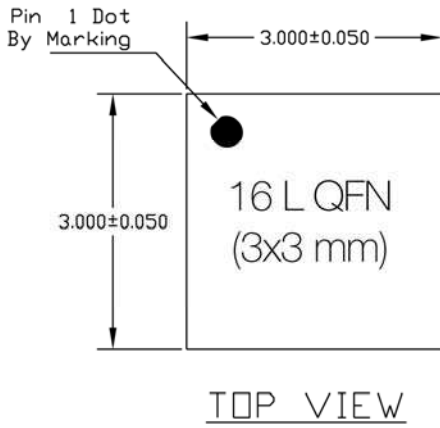

Figure 12. Package Drawing



QFN 3x3 mm		
A	MAX	0.800
	NOM	0.750
	MIN	0.700

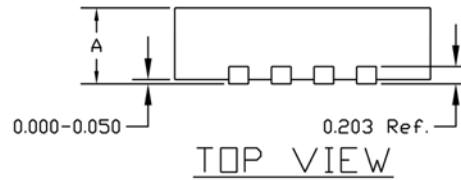
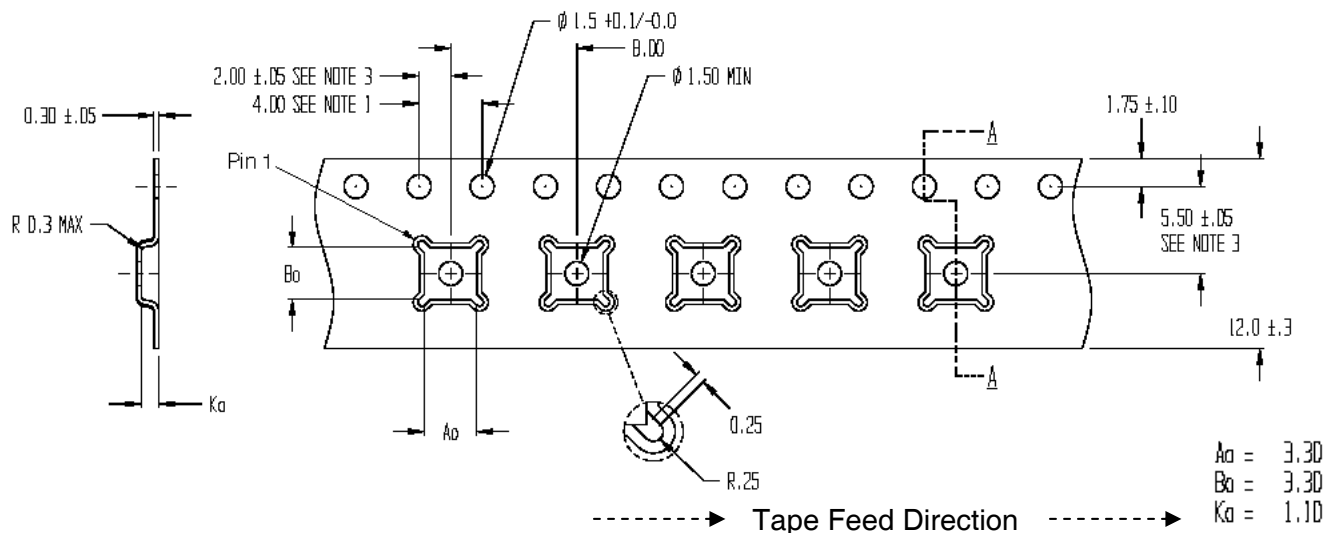

Figure 13. Tape and Reel Specifications

16-lead 3x3 mm QFN



SECTION A - A

NOTES:

1. 10 SPROCKET HOLE PITCH CUMULATIVE TOLERANCE ± 0.2
2. CAMBER IN COMPLIANCE WITH EIA 481
3. POCKET POSITION RELATIVE TO SPROCKET HOLE MEASURED AS TRUE POSITION OF POCKET, NOT POCKET HOLE

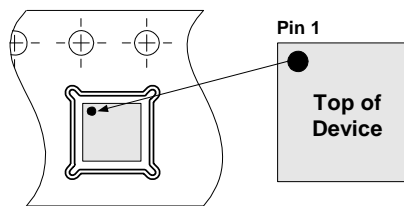

Device Orientation in Tape

Table 7. Ordering Information

Order Code	Part Marking	Description	Package	Shipping Method
EK42641-02 ¹	PE42641-EK	PE42641-16QFN 3x3mm-EK	Evaluation Kit	1 / Box
EK42641-03 ¹	PE42641-EK	PE42641-16QFN 3x3mm-EK	Evaluation Kit	1 / Box
PE42641MLIBB-Z ¹	42641	PE42641G-16QFN 3x3mm-3000C	Green 16-lead 3x3mm QFN	3000 units / T&R
PE42641MLBC-Z ²	42641	PE42641G-16QFN 3x3mm-3000C	Green 16-lead 3x3mm QFN	3000 units / T&R

- Notes: 1. Hana – AYT (Thailand) assembly house. Please contact factory for assembly house details.
2. Unisem assembly house. Please contact factory for assembly house details.

Sales Contact and Information

For sales and contact information please visit www.psemi.com.

Advance Information: The product is in a formative or design stage. The datasheet contains design target specifications for product development. Specifications and features may change in any manner without notice.
Preliminary Specification: The datasheet contains preliminary data. Additional data may be added at a later date. Peregrine reserves the right to change specifications at any time without notice in order to supply the best possible product.
Product Specification: The datasheet contains final data. In the event Peregrine decides to change the specifications, Peregrine will notify customers of the intended changes by issuing a CNF (Customer Notification Form).
The information in this datasheet is believed to be reliable. However, Peregrine assumes no liability for the use of this information. Use shall be entirely at the user's own risk.

No patent rights or licenses to any circuits described in this datasheet are implied or granted to any third party. Peregrine's products are not designed or intended for use in devices or systems intended for surgical implant, or in other applications intended to support or sustain life, or in any application in which the failure of the Peregrine product could create a situation in which personal injury or death might occur. Peregrine assumes no liability for damages, including consequential or incidental damages, arising out of the use of its products in such applications.
The Peregrine name, logo, UltraCMOS and UTSi are registered trademarks and HaRP, MultiSwitch and DuNE are trademarks of Peregrine Semiconductor Corp.