

### Product Description

The PE4257 is a high-isolation UltraCMOS™ Switch designed for wireless applications, covering a broad frequency range from near DC up to 3000 MHz. This single-supply SPDT switch integrates a two-pin CMOS control interface. It also provides low insertion loss with extremely low bias requirements while operating on a single 3-volt supply. In a typical wireless application, the PE4257 provides unprecedented isolation and integration.

The PE4257 is manufactured on Peregrine's UltraCMOS™ process, a patented variation of silicon-on-insulator (SOI) technology on a sapphire substrate, offering the performance of GaAs with the economy and integration of conventional CMOS.

Figure 1. Functional Diagram

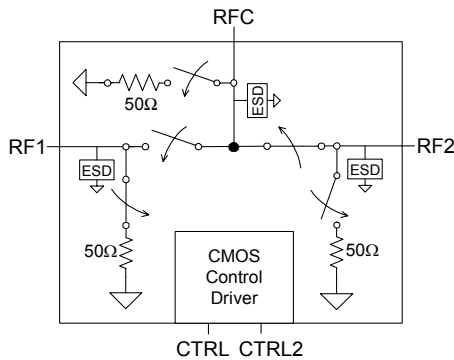

### 50 Ω SPDT Absorptive UltraCMOS™ DC – 3.0 GHz RF Switch

#### Features

- 50 Ω characteristic impedance
- Integrated 50 Ω 0.25 watt terminations
- High input IP3 > +55 dBm
- High isolation 64 dB at 1000 MHz
- Low insertion loss: typically 0.75 dB at 1000 MHz and 0.95 dB at 2000 MHz
- LV CMOS two-pin control
- Single +3 volt supply operation
- Low current consumption: 8 μA

Figure 2. Package Type

20-Lead 4x4 mm QFN



Table 1. Electrical Specifications @ +25 °C, V<sub>DD</sub> = 3.0 V (Z<sub>S</sub> = Z<sub>L</sub> = 50 Ω)

Parameter	Condition	Minimum	Typical	Maximum	Units
Operating Frequency <sup>1</sup>		DC		3000	MHz
Insertion Loss	1000 MHz		0.75	0.95	dB
	2000 MHz		0.95	1.15	
	3000 MHz		1.2	1.4	
Isolation Input to Output	1000 MHz	61	64		dB
	2000 MHz	46	50		
	3000 MHz	40	44		
Isolation Output to Output	1000 MHz	57	63		dB
	2000 MHz	54	60		
	3000 MHz	42	48		
Input IP2	5 MHz - 1000 MHz		80		dBm
Input IP3	5 MHz - 1000 MHz	50	55		dBm
Input 1dB Compression <sup>2</sup>	1000 MHz	29	31		dBm
Switching Time	50% CTRL to 10 / 90 RF		2		μs
Video Feedthrough <sup>3</sup>	5 MHz - 1000 MHz			15	mV <sub>pp</sub>

Notes: 1. Device linearity will begin to degrade below 5 MHz.

2. Note Absolute Maximum ratings in Table 3.

3. Measured with a 1 ns risetime, 0/3 V pulse and 500 MHz bandwidth

Figure 3. Pin Configuration (Top View)

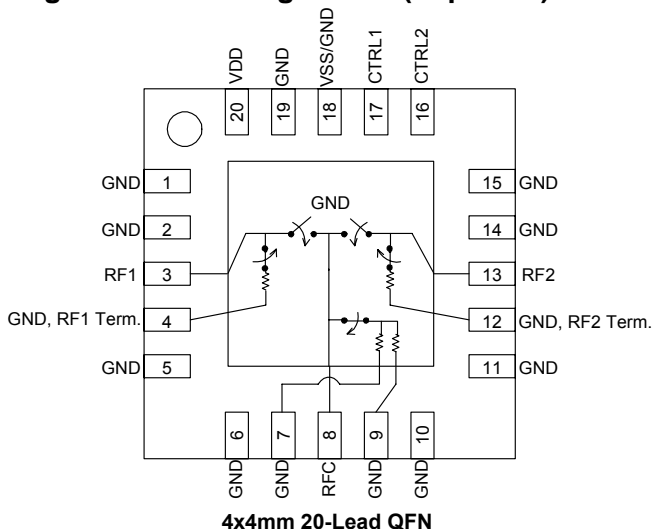

Table 2. Pin Descriptions

No.	Name	Description
1	GND	RF Ground
2	GND	RF Ground
3 <sup>1</sup>	RF1	RF I/O
4	GND	RF Ground
5	GND	RF Ground
6	GND	RF Ground
7	GND	RF Ground
8 <sup>1</sup>	RFC	RF Common
9	GND	RF Ground
10	GND	RF Ground
11	GND	RF Ground
12	GND	RF Ground
13 <sup>1</sup>	RF2	RF I/O
14	GND	RF Ground
15	GND	RF Ground
16 <sup>2</sup>	CTRL2	Control 2
17 <sup>2</sup>	CTRL1	Control 1
18 <sup>3</sup>	VSS / GND	Negative Supply Option
19	GND	Digital Ground
20	VDD	Supply
Pad	GND	RF Ground Pad

- Notes: 1. RF pins 3, 8, and 13 must be at 0 VDC. The RF pins do not require DC blocking capacitors for proper operation if the 0 VDC requirement is met.
2. Pins 16 and 17 are the CMOS controls that set the four operating states.
3. Connect pin 18 to GND to enable the negative voltage generator. Connect pin 18 to V<sub>SS</sub> (-3 V) to bypass and disable internal -3 V supply generator. See paragraph "Switching Frequency."

Table 3. Absolute Maximum Ratings

Symbol	Parameter/Condition	Min	Max	Units
V <sub>DD</sub>	Power supply voltage	-0.3	4.0	V
V <sub>i</sub>	Voltage on any DC input	-0.3	V <sub>DD</sub> + 0.3	V
P <sub>RF</sub>	RF power on RFC, RF1, RF2 On Port/ Terminated Port		33/24	dBm
T <sub>ST</sub>	Storage temperature	-65	+150	°C
T <sub>OP</sub>	Operating temperature	-40	+85	°C
V <sub>ESD</sub>	ESD voltage (Human Body Model)	1000		V

Exceeding absolute maximum ratings may cause permanent damage. Operation should be restricted to the limits in the Operating Ranges table. Operation between operating range maximum and absolute maximum for extended periods may reduce reliability.

Table 4. Operating Ranges @ 25 °C

Parameter	Min	Typ	Max	Unit
V <sub>DD</sub> Power Supply	2.7	3.0	3.3	V
I <sub>DD</sub> Power Supply Current (V <sub>DD</sub> = 3V, V <sub>CNTL</sub> = 3V)		8	20	μA
Control Voltage High	0.70 V <sub>DD</sub>			V
Control Voltage Low	0		0.30 V <sub>DD</sub>	V

### Latch-Up Avoidance

Unlike conventional CMOS devices, UltraCMOS™ devices are immune to latch-up.

### Electrostatic Discharge (ESD) Precautions

When handling this UltraCMOS™ device, observe the same precautions that you would use with other ESD-sensitive devices. Although this device contains circuitry to protect it from damage due to ESD, precautions should be taken to avoid exceeding the rating specified.

### Switching Frequency

The PE4257 has a maximum 25 kHz switching rate when the internal negative voltage generator is used (pin 18=GND). The rate at which the PE4257 can be switched is only limited to the switching time if an external -3 V supply is provided at (pin18=V<sub>SS</sub>).

Table 5. Truth Table

CTRL1	CTRL2	RFC – RF1	RFC – RF2
Low	Low	OFF	OFF
Low	High	OFF	ON
High	Low	ON	OFF
High	High	N/A <sup>1</sup>	N/A <sup>1</sup>

- Notes: 1. The operation of the PE4257 is not supported or characterized in the C1=V<sub>DD</sub> and C2=V<sub>DD</sub> state.

**Typical Performance Data @ 25°C (Unless Otherwise Noted)  
(50-ohm impedance)**

**Figure 4. Insertion Loss – Input - Output**

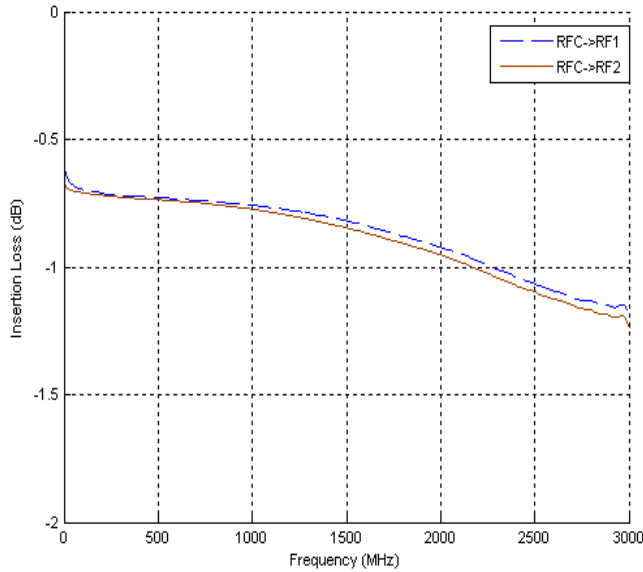

**Figure 5. RF1 to RF2 Isolation**

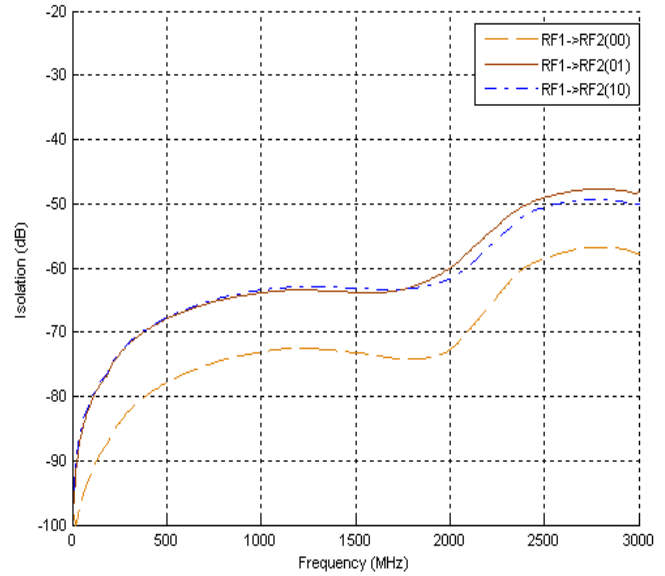

**Figure 6. Isolation – RFC to RF1/RF2**

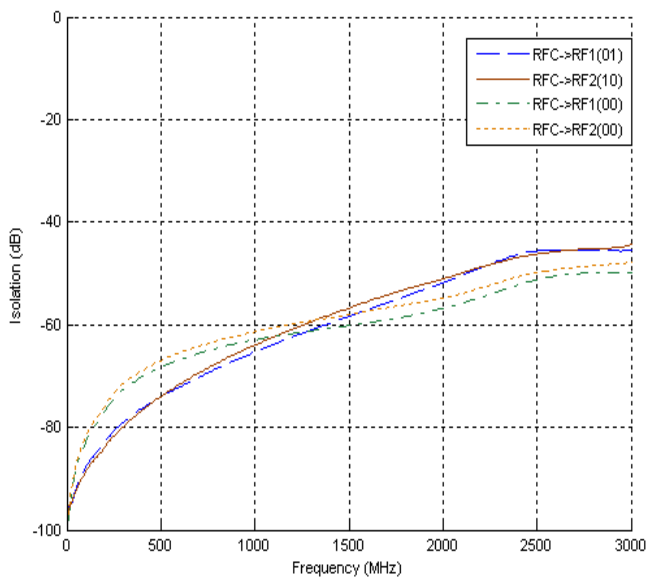

**Figure 7. Return Loss**

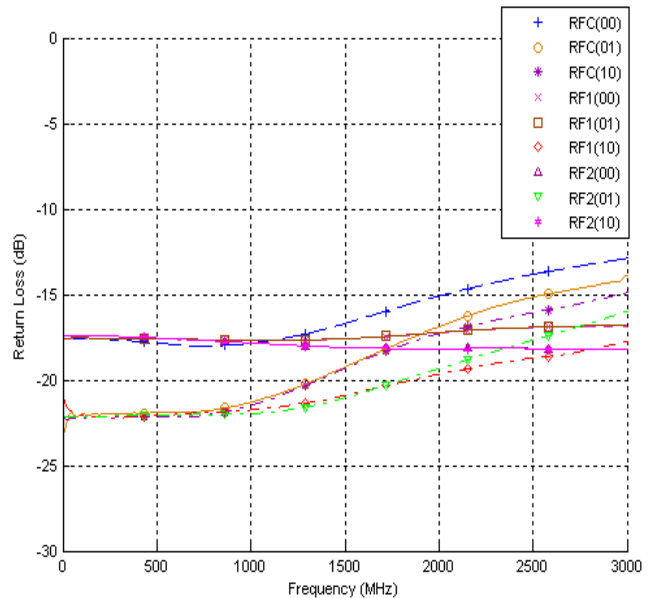

## Evaluation Kit

The SPDT Switch Evaluation Kit board was designed to ease customer evaluation of the PE4257 SPDT switch. The RF common port is connected through a 50 Ω transmission line to J2. Port 1 and Port 2 are connected through 50 Ω transmission lines to J1 and J3. A through transmission line connects SMA connectors J4 and J5. This transmission line can be used to estimate the loss of the PCB over the environmental conditions being evaluated.

The board is constructed of a four metal layer FR4 material with a total thickness of 0.031". The transmission lines were designed using a coplanar waveguide with ground plane (28 mil core, 47.6 mil width, 30mil gap).

Note the number of vias surrounding the device in the layout shown in Figure 8. These vias are critical for obtaining the specified isolation performance for the device shown in this datasheet.

J6 provides a means for controlling DC and digital inputs to the device. The provided jumpers short the package pin to ground for logic low. When the jumper is removed, the pin is pulled up to VDD for logic high. When the jumper is in place, 3 μA of current will flow through the 1 MΩ pull up resistor. This extra current should not be attributed to the requirements of the device.

Figure 8. Evaluation Board Layouts

Peregrine Specification 101/0151

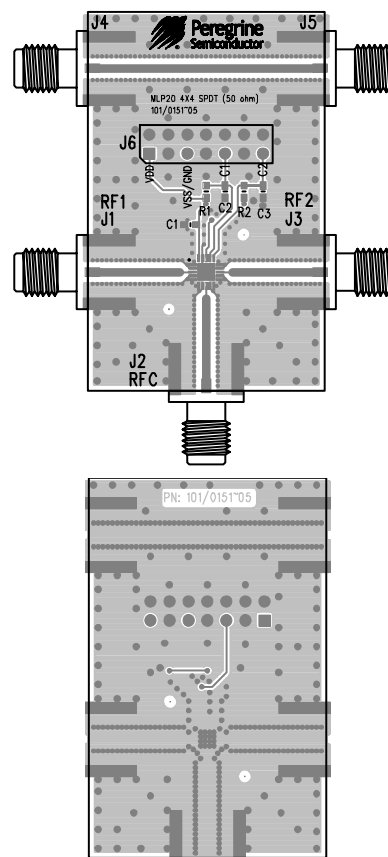
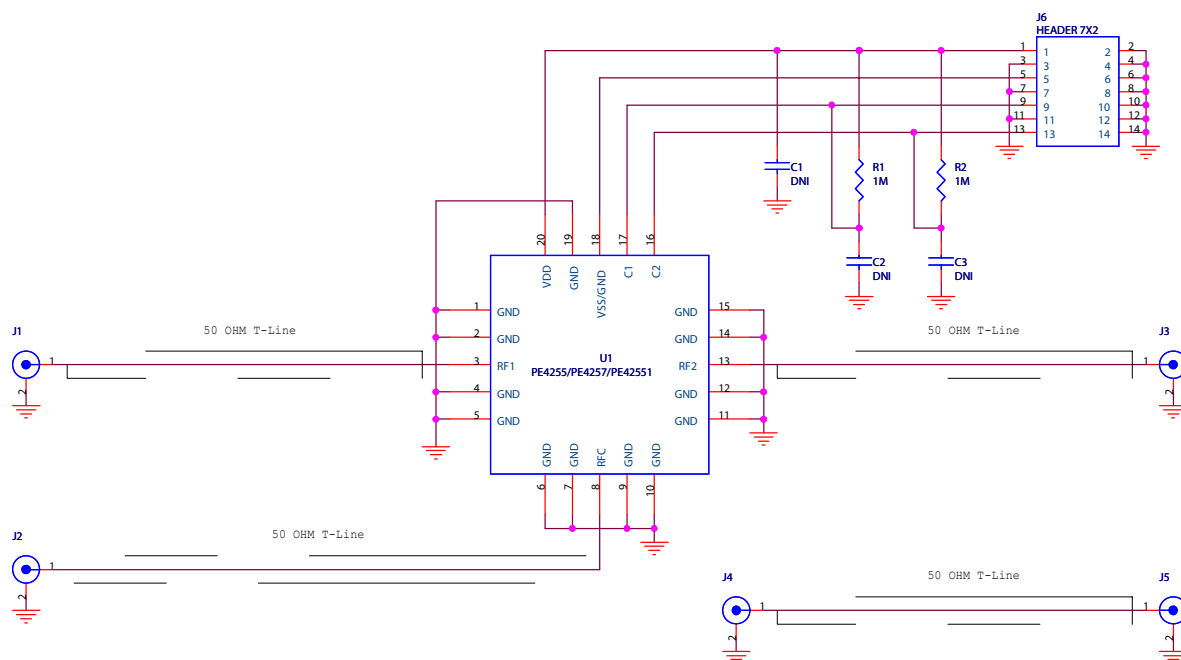

Figure 9. Evaluation Board Schematic

Peregrine Specification 102/0198



**Figure 10. Package Drawing**

20-Lead 4x4 QFN

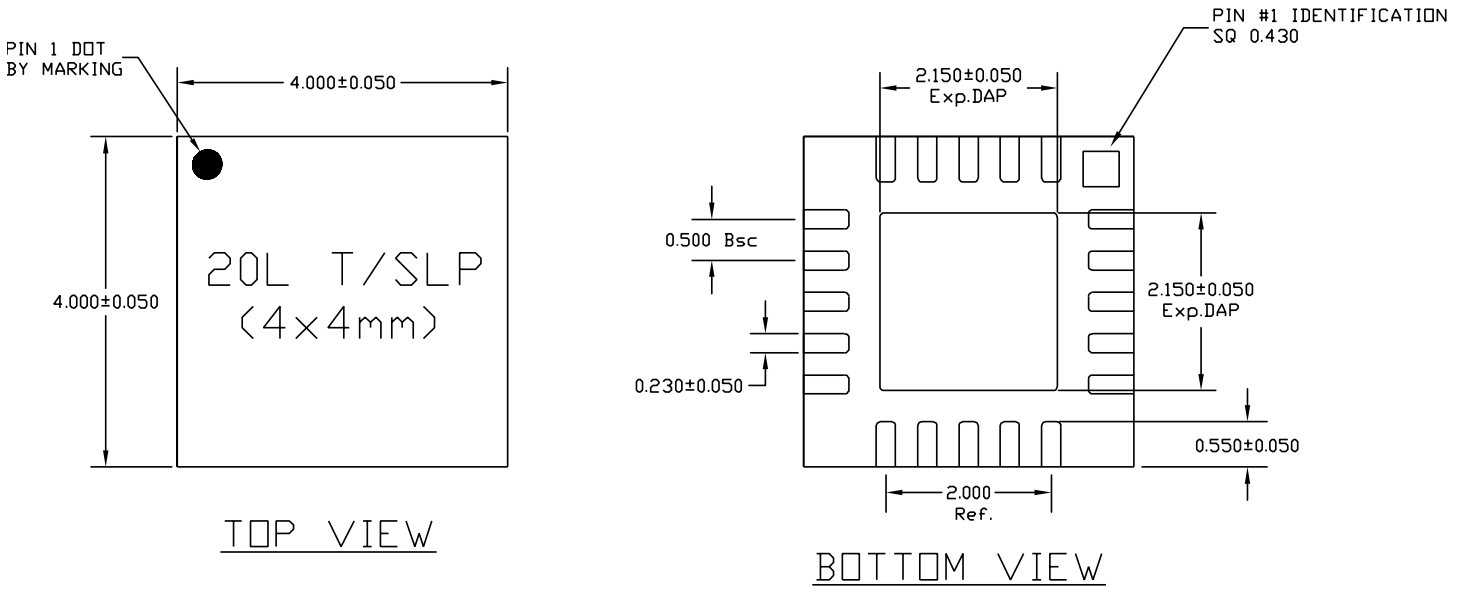

**NOTE:**

1) TSLP AND SLP SHARE THE SAME EXPOSE OUTLINE BUT WITH DIFFERENT THICKNESS:

		TSLP	SLP
A	MAX.	0.800	0.900
	NOM.	0.750	0.850
	MIN.	0.700	0.800

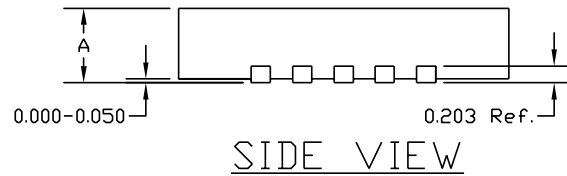

**Figure 11. Tape and Reel Drawing**

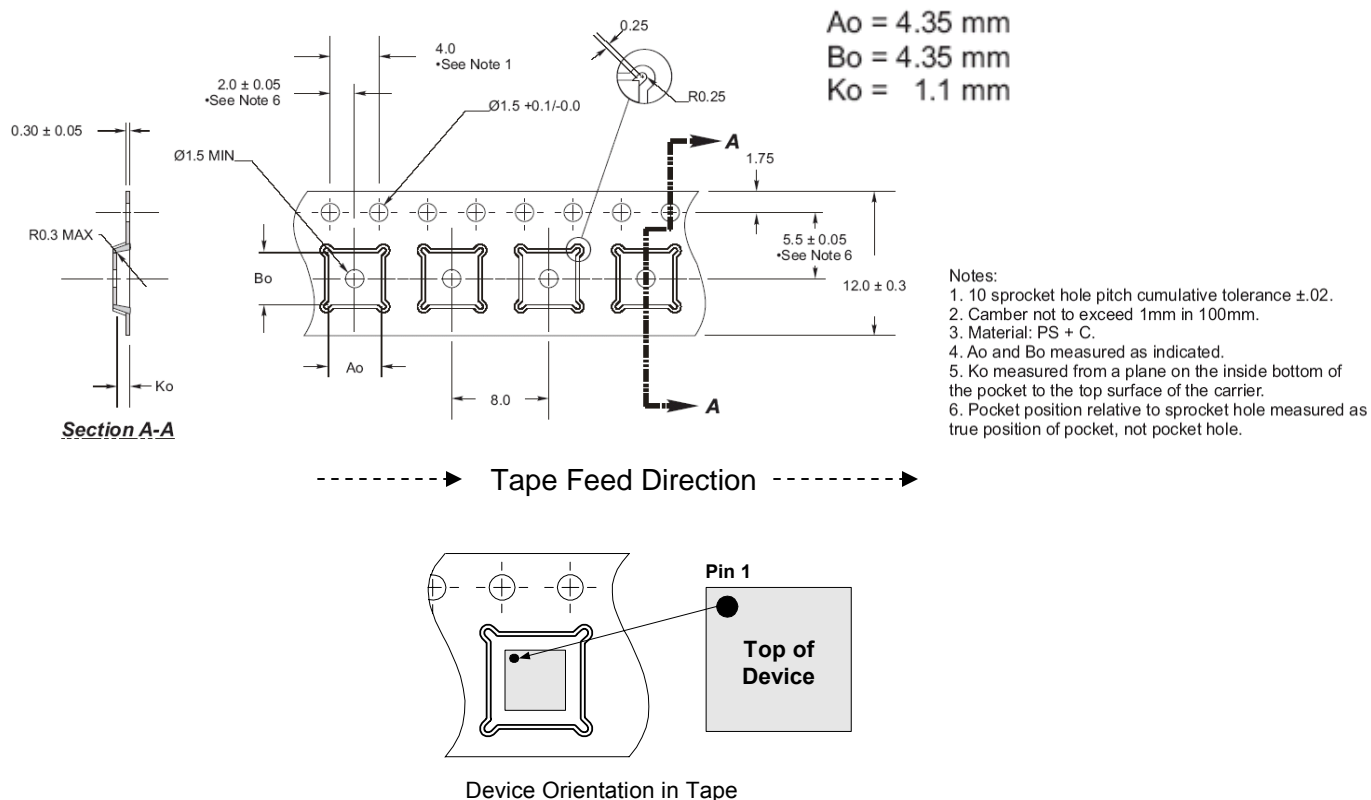

**Figure 12. Marking Specifications**

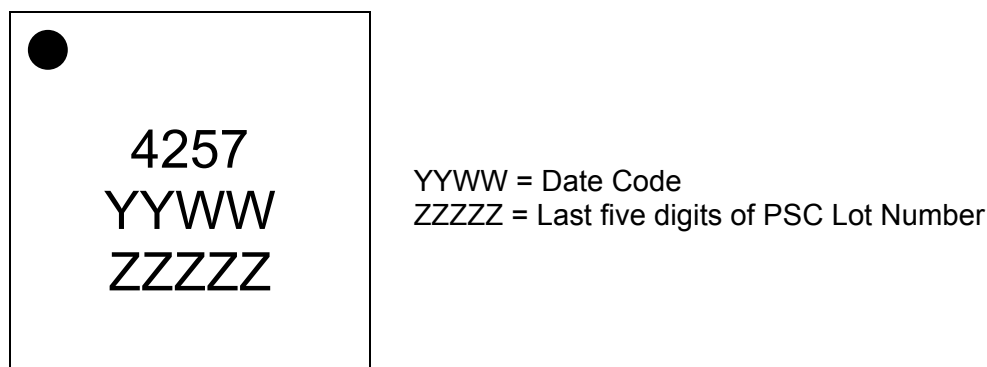

**Table 6. Ordering Information**

Order Code	Part Marking	Description	Package	Shipping Method
4257-00	PE4257-EK	PE4257-20QFN 4x4mm-EK	Evaluation Kit	1 / Box
4257-51	4257	PE4257G-20QFN 4x4mm-75A	Green 20-lead 4x4mm QFN	75 units / cut tape from reel
4257-52	4257	PE4257G-20QFN 4x4mm-3000C	Green 20-lead 4x4mm QFN	3000 units / T&R

## Sales Offices

### *The Americas*

#### **Peregrine Semiconductor Corporation**

9380 Carroll Park Drive  
San Diego, CA 92121  
Tel: 858-731-9400  
Fax: 858-731-9499

### *Europe*

#### **Peregrine Semiconductor Europe**

Bâtiment Maine  
13-15 rue des Quatre Vents  
F-92380 Garches, France  
Tel: +33-1-4741-9173  
Fax : +33-1-4741-9173

### **Hi-Rel and Defense Products**

#### **Americas:**

Tel: 858-731-9453

#### **Europe, Asia Pacific:**

180 Rue Jean de Guiramand  
13852 Aix-En-Provence Cedex 3, France  
Tel: +33-4-4239-3361  
Fax: +33-4-4239-7227

#### **Peregrine Semiconductor, Asia Pacific (APAC)**

Shanghai, 200040, P.R. China  
Tel: +86-21-5836-8276  
Fax: +86-21-5836-7652

#### **Peregrine Semiconductor, Korea**

#B-2607, Kolon Tripolis, 210  
Geumgok-dong, Bundang-gu, Seongnam-si  
Gyeonggi-do, 463-943 South Korea  
Tel: +82-31-728-3939  
Fax: +82-31-728-3940

#### **Peregrine Semiconductor K.K., Japan**

Teikoku Hotel Tower 10B-6  
1-1-1 Uchisaiwai-cho, Chiyoda-ku  
Tokyo 100-0011 Japan  
Tel: +81-3-3502-5211  
Fax: +81-3-3502-5213

For a list of representatives in your area, please refer to our Web site at: [www.psemi.com](http://www.psemi.com)

## Data Sheet Identification

### **Advance Information**

The product is in a formative or design stage. The data sheet contains design target specifications for product development. Specifications and features may change in any manner without notice.

### **Preliminary Specification**

The data sheet contains preliminary data. Additional data may be added at a later date. Peregrine reserves the right to change specifications at any time without notice in order to supply the best possible product.

### **Product Specification**

The data sheet contains final data. In the event Peregrine decides to change the specifications, Peregrine will notify customers of the intended changes by issuing a DCN (Document Change Notice).

The information in this data sheet is believed to be reliable. However, Peregrine assumes no liability for the use of this information. Use shall be entirely at the user's own risk.

No patent rights or licenses to any circuits described in this data sheet are implied or granted to any third party.

Peregrine's products are not designed or intended for use in devices or systems intended for surgical implant, or in other applications intended to support or sustain life, or in any application in which the failure of the Peregrine product could create a situation in which personal injury or death might occur. Peregrine assumes no liability for damages, including consequential or incidental damages, arising out of the use of its products in such applications.

The Peregrine name, logo, and UTSi are registered trademarks and UltraCMOS, HaRP, MultiSwitch and DuNE are trademarks of Peregrine Semiconductor Corp.