

CAT25010, CAT25020, CAT25040



ON Semiconductor®

<http://onsemi.com>

1-Kb, 2-Kb and 4-Kb SPI Serial CMOS EEPROM

Description

The CAT25010/20/40 are 1-Kb/2-Kb/4-Kb Serial CMOS EEPROM devices internally organized as 128x8/256x8/512x8 bits. They feature a 16-byte page write buffer and support the Serial Peripheral Interface (SPI) protocol. The device is enabled through a Chip Select (\overline{CS}) input. In addition, the required bus signals are a clock input (SCK), data input (SI) and data output (SO) lines. The \overline{HOLD} input may be used to pause any serial communication with the CAT25010/20/40 device. These devices feature software and hardware write protection, including partial as well as full array protection.

Features

- 20 MHz (5 V) SPI Compatible
- 1.8 V to 5.5 V Supply Voltage Range
- SPI Modes (0,0) & (1,1)
- 16-byte Page Write Buffer
- Self-timed Write Cycle
- Hardware and Software Protection
- Block Write Protection
 - Protect 1/4, 1/2 or Entire EEPROM Array
- Low Power CMOS Technology
- 1,000,000 Program/Erase Cycles
- 100 Year Data Retention
- Industrial and Extended Temperature Range
- PDIP, SOIC, TSSOP 8-Lead and TDFN, UDFN 8-Pad Packages
- These Devices are Pb-Free, Halogen Free/BFR Free, and RoHS Compliant

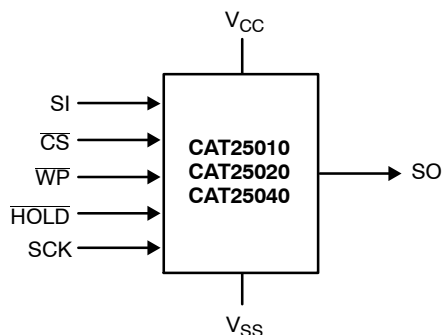
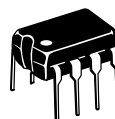
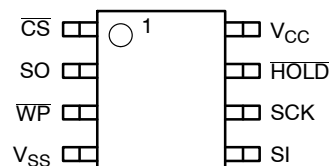

Figure 1. Functional Symbol



PIN CONFIGURATION



PDIP (L), SOIC (V), MSOP (Z)
TSSOP (Y), TDFN* (VP2), UDFN (HU4)

For the location of Pin 1, please consult the corresponding package drawing.

* Not recommended for new designs

PIN FUNCTION

Pin Name	Function
\overline{CS}	Chip Select
SO	Serial Data Output
\overline{WP}	Write Protect
V _{SS}	Ground
SI	Serial Data Input
SCK	Serial Clock
\overline{HOLD}	Hold Transmission Input
V _{CC}	Power Supply

ORDERING INFORMATION

See detailed ordering and shipping information in the package dimensions section on page 17 of this data sheet.

CAT25010, CAT25020, CAT25040

Table 1. ABSOLUTE MAXIMUM RATINGS

Parameters	Ratings	Units
Operating Temperature	-45 to +130	°C
Storage Temperature	-65 to +150	°C
Voltage on any Pin with Respect to Ground (Note 1)	-0.5 to $V_{CC} + 0.5$	V

Stresses exceeding Maximum Ratings may damage the device. Maximum Ratings are stress ratings only. Functional operation above the Recommended Operating Conditions is not implied. Extended exposure to stresses above the Recommended Operating Conditions may affect device reliability.

Table 2. RELIABILITY CHARACTERISTICS (Note 2)

Symbol	Parameter	Min	Units
N_{END} (Note 3)	Endurance	1,000,000	Program / Erase Cycles
T_{DR}	Data Retention	100	Years

Table 3. D.C. OPERATING CHARACTERISTICS

($V_{CC} = 1.8\text{ V to }5.5\text{ V}$, $T_A = -40^\circ\text{C to }+85^\circ\text{C}$ and $V_{CC} = 2.5\text{ V to }5.5\text{ V}$, $T_A = -40^\circ\text{C to }+125^\circ\text{C}$, unless otherwise specified.)

Symbol	Parameter	Test Conditions	Min	Max	Units		
I_{CC}	Supply Current	Read, Write, $V_{CC} = 5.0\text{ V}$, SO open	10 MHz / $-40^\circ\text{C to }85^\circ\text{C}$		2	mA	
			5 MHz / $-40^\circ\text{C to }125^\circ\text{C}$		2	mA	
I_{SB1}	Standby Current	$V_{IN} = \text{GND or }V_{CC}$, $\overline{CS} = V_{CC}$, $\overline{WP} = V_{CC}$, $V_{CC} = 5.0\text{ V}$			2	μA	
I_{SB2}	Standby Current	$V_{IN} = \text{GND or }V_{CC}$, $\overline{CS} = V_{CC}$, $\overline{WP} = \text{GND}$, $V_{CC} = 5.0\text{ V}$	$T_A = -40^\circ\text{C to }+85^\circ\text{C}$		4	μA	
			$T_A = -40^\circ\text{C to }+125^\circ\text{C}$		5	μA	
I_L	Input Leakage Current	$V_{IN} = \text{GND or }V_{CC}$		-2	2	μA	
I_{LO}	Output Leakage Current	$\overline{CS} = V_{CC}$, $V_{OUT} = \text{GND or }V_{CC}$	$T_A = -40^\circ\text{C to }+85^\circ\text{C}$		-1	1	μA
			$T_A = -40^\circ\text{C to }+125^\circ\text{C}$		-1	2	μA
V_{IL}	Input Low Voltage		-0.5	$0.3 V_{CC}$		V	
V_{IH}	Input High Voltage		$0.7 V_{CC}$	$V_{CC} + 0.5$		V	
V_{OL1}	Output Low Voltage	$V_{CC} > 2.5\text{ V}$, $I_{OL} = 3.0\text{ mA}$			0.4	V	
V_{OH1}	Output High Voltage	$V_{CC} > 2.5\text{ V}$, $I_{OH} = -1.6\text{ mA}$	$V_{CC} - 0.8\text{ V}$			V	
V_{OL2}	Output Low Voltage	$V_{CC} > 1.8\text{ V}$, $I_{OL} = 150\ \mu\text{A}$			0.2	V	
V_{OH2}	Output High Voltage	$V_{CC} > 1.8\text{ V}$, $I_{OH} = -100\ \mu\text{A}$	$V_{CC} - 0.2\text{ V}$			V	

Table 4. PIN CAPACITANCE (Note 2) ($T_A = 25^\circ\text{C}$, $f = 1.0\text{ MHz}$, $V_{CC} = +5.0\text{ V}$)

Symbol	Test	Conditions	Min	Typ	Max	Units
C_{OUT}	Output Capacitance (SO)	$V_{OUT} = 0\text{ V}$			8	pF
C_{IN}	Input Capacitance (\overline{CS} , SCK, SI, \overline{WP} , HOLD)	$V_{IN} = 0\text{ V}$			8	pF

- The DC input voltage on any pin should not be lower than -0.5 V or higher than $V_{CC} + 0.5\text{ V}$. During transitions, the voltage on any pin may undershoot to no less than -1.5 V or overshoot to no more than $V_{CC} + 1.5\text{ V}$, for periods of less than 20 ns.
- These parameters are tested initially and after a design or process change that affects the parameter according to appropriate AEC-Q100 and JEDEC test methods.
- Page Mode, $V_{CC} = 5\text{ V}$, 25°C .

CAT25010, CAT25020, CAT25040

Table 5. A.C. CHARACTERISTICS – Mature Product

($T_A = -40^{\circ}\text{C}$ to $+85^{\circ}\text{C}$ (Industrial) and $T_A = -40^{\circ}\text{C}$ to $+125^{\circ}\text{C}$ (Extended).) (Notes 4, 8)

Symbol	Parameter	$V_{CC} = 1.8\text{ V} - 5.5\text{ V} / -40^{\circ}\text{C to }+85^{\circ}\text{C}$ $V_{CC} = 2.5\text{ V} - 5.5\text{ V} / -40^{\circ}\text{C to }+125^{\circ}\text{C}$		$V_{CC} = 2.5\text{ V} - 5.5\text{ V}$ $-40^{\circ}\text{C to }+85^{\circ}\text{C}$		Units
		Min	Max	Min	Max	
f _{SCK}	Clock Frequency	DC	5	DC	10	MHz
t _{SU}	Data Setup Time	40		20		ns
t _H	Data Hold Time	40		20		ns
t _{WH}	SCK High Time	75		40		ns
t _{WL}	SCK Low Time	75		40		ns
t _{LZ}	HOLD to Output Low Z		50		25	ns
t _{RI} (Note 5)	Input Rise Time		2		2	μs
t _{FI} (Note 5)	Input Fall Time		2		2	μs
t _{HD}	HOLD Setup Time	0		0		ns
t _{CD}	HOLD Hold Time	10		10		ns
t _V	Output Valid from Clock Low		75		40	ns
t _{HO}	Output Hold Time	0		0		ns
t _{DIS}	Output Disable Time		50		20	ns
t _{HZ}	HOLD to Output High Z		100		25	ns
t _{CS}	CS High Time	140		70		ns
t _{CSS}	CS Setup Time	30		15		ns
t _{CSH}	CS Hold Time	30		15		ns
t _{CNS}	CS Inactive Setup Time	20		15		ns
t _{CNH}	CS Inactive Hold Time	20		15		ns
t _{WPS}	WP Setup Time	10		10		ns
t _{WPH}	WP Hold Time	10		10		ns
t _{WC} (Note 7)	Write Cycle Time		5		5	ms

Table 6. POWER-UP TIMING (Notes 5, 6)

Symbol	Parameter	Max	Units
t _{PUR}	Power-up to Read Operation	1	ms
t _{PUW}	Power-up to Write Operation	1	ms

4. AC Test Conditions:

Input Pulse Voltages: $0.3 V_{CC}$ to $0.7 V_{CC}$
 Input rise and fall times: $\leq 10\text{ ns}$
 Input and output reference voltages: $0.5 V_{CC}$
 Output load: current source $I_{OL\text{ max}}/I_{OH\text{ max}}$; $C_L = 50\text{ pF}$

5. This parameter is tested initially and after a design or process change that affects the parameter.

6. t_{PUR} and t_{PUW} are the delays required from the time V_{CC} is stable until the specified operation can be initiated.

7. t_{WC} is the time from the rising edge of CS after a valid write sequence to the end of the internal write cycle.

8. **All Chip Select (CS) timing parameters are defined relative to the positive clock edge (Figure 2). t_{CSH} timing specification is valid for die revision D and higher. The die revision D is identified by letter "D" or a dedicated marking code on top of the package. For previous product revision (Rev. C) the t_{CSH} is defined relative to the negative clock edge (please refer to data sheet Doc. No. MD-1006 Rev. U)**

CAT25010, CAT25020, CAT25040

Table 7. A.C. CHARACTERISTICS – New Product (Rev E)

($T_A = -40^{\circ}\text{C}$ to $+85^{\circ}\text{C}$ (Industrial) and $T_A = -40^{\circ}\text{C}$ to $+125^{\circ}\text{C}$ (Extended), unless otherwise specified.) (Note 9)

Symbol	Parameter	$V_{CC} = 1.8\text{ V} - 5.5\text{ V}$ -40°C to $+85^{\circ}\text{C}$		$V_{CC} = 2.5\text{ V} - 5.5\text{ V}$ -40°C to $+125^{\circ}\text{C}$		$V_{CC} = 4.5\text{ V} - 5.5\text{ V}$ -40°C to $+85^{\circ}\text{C}$		Units
		Min	Max	Min	Max	Min	Max	
f_{SCK}	Clock Frequency	DC	5	DC	10	DC	20	MHz
t_{SU}	Data Setup Time	20		10		5		ns
t_H	Data Hold Time	20		10		5		ns
t_{WH}	SCK High Time	75		40		20		ns
t_{WL}	SCK Low Time	75		40		20		ns
t_{LZ}	HOLD to Output Low Z		50		25		25	ns
t_{RI} (Note 10)	Input Rise Time		2		2		2	μs
t_{FI} (Note 10)	Input Fall Time		2		2		2	μs
t_{HD}	HOLD Setup Time	0		0		0		ns
t_{CD}	HOLD Hold Time	10		10		5		ns
t_V	Output Valid from Clock Low		70		35		20	ns
t_{HO}	Output Hold Time	0		0		0		ns
t_{DIS}	Output Disable Time		50		20		20	ns
t_{HZ}	HOLD to Output High Z		100		25		25	ns
t_{CS}	\overline{CS} High Time	80		40		20		ns
t_{CSS}	\overline{CS} Setup Time	30		30		15		ns
t_{CSH}	\overline{CS} Hold Time	30		30		20		ns
t_{CNS}	\overline{CS} Inactive Setup Time	20		20		15		ns
t_{CNH}	\overline{CS} Inactive Hold Time	20		20		15		ns
t_{WPS}	\overline{WP} Setup Time	10		10		10		ns
t_{WPH}	\overline{WP} Hold Time	10		10		10		ns
t_{WC} (Note 12)	Write Cycle Time		5		5		5	ms

Table 8. POWER-UP TIMING (Notes 10, 11)

Symbol	Parameter	Min	Max	Units
t_{PUR}	Power-up to Read Operation	0.1	1	ms
t_{PUW}	Power-up to Write Operation	0.1	1	ms

9. AC Test Conditions:

Input Pulse Voltages: $0.3 V_{CC}$ to $0.7 V_{CC}$
 Input rise and fall times: $\leq 10\text{ ns}$
 Input and output reference voltages: $0.5 V_{CC}$
 Output load: current source $I_{OL\ max}/I_{OH\ max}$; $C_L = 30\text{ pF}$

10. This parameter is tested initially and after a design or process change that affects the parameter.

11. t_{PUR} and t_{PUW} are the delays required from the time V_{CC} is stable at the operating voltage until the specified operation can be initiated.

12. t_{WC} is the time from the rising edge of \overline{CS} after a valid write sequence to the end of the internal write cycle.

CAT25010, CAT25020, CAT25040

Pin Description

SI: The serial data input pin accepts op-codes, addresses and data. In SPI modes (0,0) and (1,1) input data is latched on the rising edge of the SCK clock input.

SO: The serial data output pin is used to transfer data out of the device. In SPI modes (0,0) and (1,1) data is shifted out on the falling edge of the SCK clock.

SCK: The serial clock input pin accepts the clock provided by the host and used for synchronizing communication between host and CAT25010/20/40.

\overline{CS} : The chip select input pin is used to enable/disable the CAT25010/20/40. When \overline{CS} is high, the SO output is tri-stated (high impedance) and the device is in Standby Mode (unless an internal write operation is in progress). *Every communication session between host and CAT25010/20/40 must be preceded by a high to low transition and concluded with a low to high transition of the \overline{CS} input.*

\overline{WP} : The write protect input pin will allow all write operations to the device when held high. When \overline{WP} pin is tied low all write operations are inhibited.

HOLD: The \overline{HOLD} input pin is used to pause transmission between host and CAT25010/20/40, without having to retransmit the entire sequence at a later time. To pause, \overline{HOLD} must be taken low and to resume it must be taken back high, with the SCK input low during both transitions. When not used for pausing, the \overline{HOLD} input should be tied to V_{CC} , either directly or through a resistor.

Functional Description

The CAT25010/20/40 devices support the Serial Peripheral Interface (SPI) bus protocol, modes (0,0) and (1,1). The device contains an 8-bit instruction register. The instruction set and associated op-codes are listed in Table 9.

Reading data stored in the CAT25010/20/40 is accomplished by simply providing the READ command and an address. Writing to the CAT25010/20/40, in addition to a WRITE command, address and data, also requires enabling the device for writing by first setting certain bits in a Status Register, as will be explained later.

After a high to low transition on the \overline{CS} input pin, the CAT25010/20/40 will accept any one of the six instruction op-codes listed in Table 9 and will ignore all other possible 8-bit combinations. The communication protocol follows the timing from Figure 2.

Table 9. INSTRUCTION SET (Note 13)

Instruction	Opcode	Operation
WREN	0000 0110	Enable Write Operations
WRDI	0000 0100	Disable Write Operations
RDSR	0000 0101	Read Status Register
WRSR	0000 0001	Write Status Register
READ	0000 X011	Read Data from Memory
WRITE	0000 X010	Write Data to Memory

13. X = 0 for CAT25010, CAT25020. X = A8 for CAT25040

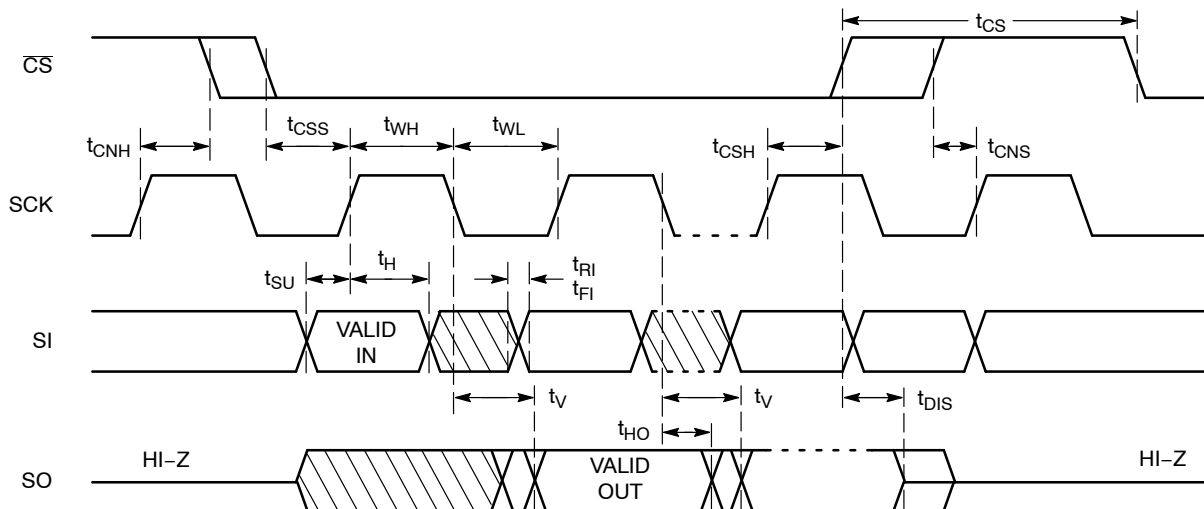

Figure 2. Synchronous Data Timing

Status Register

The Status Register, as shown in Table 10, contains a number of status and control bits.

The \overline{RDY} (Ready) bit indicates whether the device is busy with a write operation. This bit is automatically set to 1 during an internal write cycle, and reset to 0 when the device is ready to accept commands. For the host, this bit is read only.

The WEL (Write Enable Latch) bit is set/reset by the WREN/WRDI commands. When set to 1, the device is in a

Write Enable state and when set to 0, the device is in a Write Disable state.

The BP0 and BP1 (Block Protect) bits determine which blocks are currently write protected. They are set by the user with the WRSR command and are non-volatile. The user is allowed to protect a quarter, one half or the entire memory, by setting these bits according to Table 11. The protected blocks then become read-only.

CAT25010, CAT25020, CAT25040

Table 10. STATUS REGISTER

7	6	5	4	3	2	1	0
1	1	1	1	BP1	BP0	WEL	$\overline{\text{RDY}}$

Table 11. BLOCK PROTECTION BITS

Status Register Bits		Array Address Protected	Protection
BP1	BP0		
0	0	None	No Protection
0	1	CAT25010: 060–07F, CAT25020: 0C0–0FF, CAT25040: 180–1FF	Quarter Array Protection
1	0	CAT25010: 040–07F, CAT25020: 080–0FF, CAT25040: 100–1FF	Half Array Protection
1	1	CAT25010: 000–07F, CAT25020: 000–0FF, CAT25040: 000–1FF	Full Array Protection

WRITE OPERATIONS

The CAT25010/20/40 device powers up into a write disable state. The device contains a Write Enable Latch (WEL) which must be set before attempting to write to the memory array or to the status register. In addition, the address of the memory location(s) to be written must be outside the protected area, as defined by BP0 and BP1 bits from the status register.

Write Enable and Write Disable

The internal Write Enable Latch and the corresponding Status Register WEL bit are set by sending the WREN

instruction to the CAT25010/20/40. Care must be taken to take the $\overline{\text{CS}}$ input high after the WREN instruction, as otherwise the Write Enable Latch will not be properly set. WREN timing is illustrated in Figure 3. The WREN instruction must be sent prior to any WRITE or WRSR instruction.

The internal write enable latch is reset by sending the WRDI instruction as shown in Figure 4. Disabling write operations by resetting the WEL bit, will protect the device against inadvertent writes.

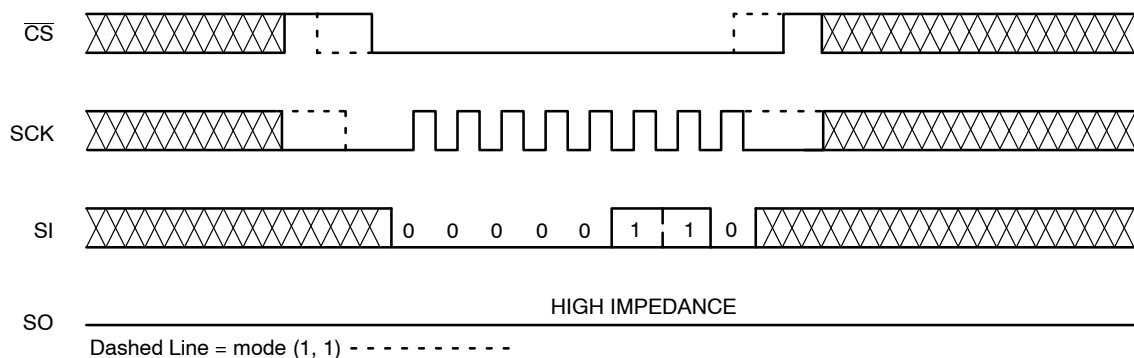

Figure 3. WREN Timing

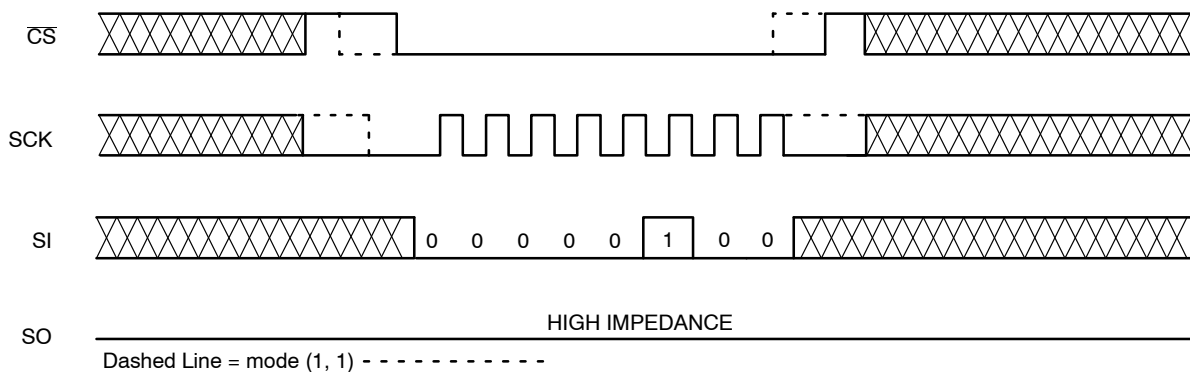

Figure 4. WRDI Timing

CAT25010, CAT25020, CAT25040

Byte Write

Once the WEL bit is set, the user may execute a write sequence, by sending a WRITE instruction, a 8-bit address and data as shown in Figure 5. For the CAT25040, bit 3 of the write instruction opcode contains A8 address bit. Internal programming will start after the low to high \overline{CS} transition. During an internal write cycle, all commands, except for RDSR (Read Status Register) will be ignored. The \overline{RDY} bit will indicate if the internal write cycle is in progress (\overline{RDY} high), or the device is ready to accept commands (\overline{RDY} low).

Page Write

After sending the first data byte to the CAT25010/20/40, the host may continue sending data, up to a total of 16 bytes, according to timing shown in Figure 6. After each data byte, the lower order address bits are automatically incremented, while the higher order address bits (page address) remain unchanged. If during this process the end of page is exceeded, then loading will “roll over” to the first byte in the page, thus possibly overwriting previously loaded data. Following completion of the write cycle, the CAT25010/20/40 is automatically returned to the write disable state.

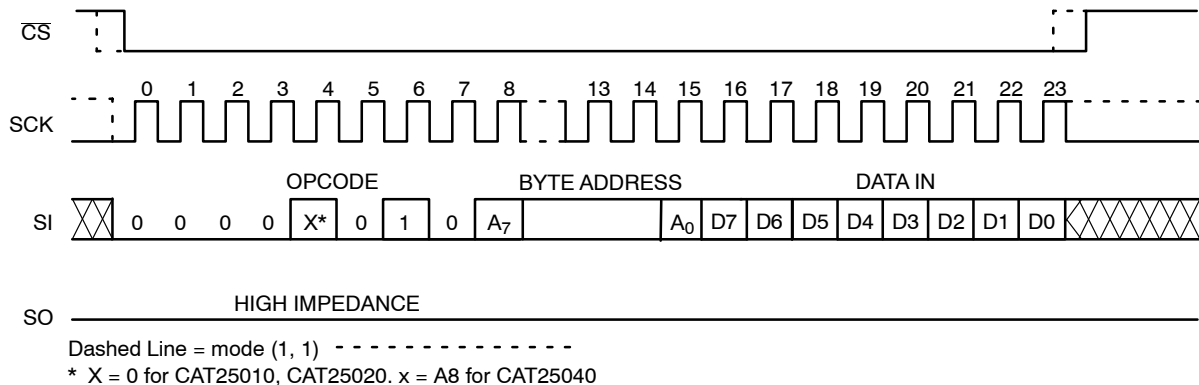

Figure 5. Byte WRITE Timing

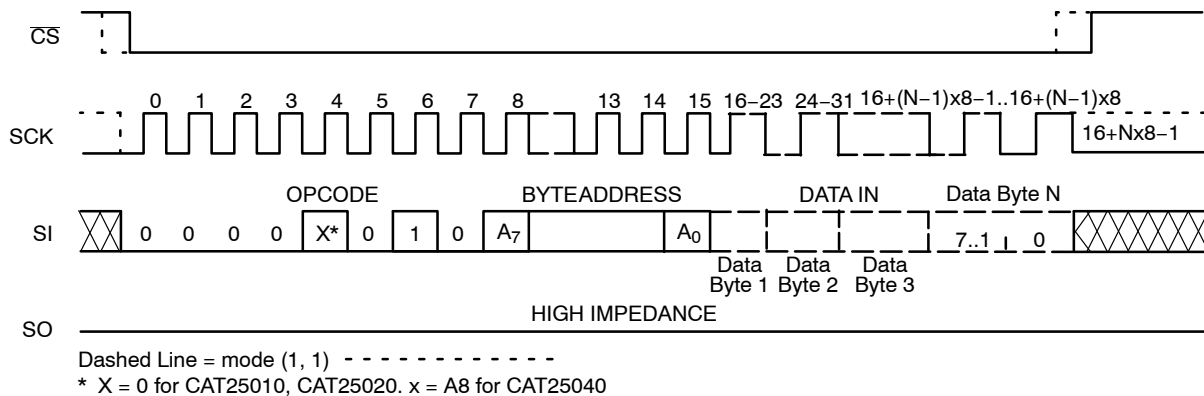

Figure 6. Page WRITE Timing

CAT25010, CAT25020, CAT25040

Write Status Register

The Status Register is written by sending a WRSR instruction according to timing shown in Figure 7. Only bits 2 and 3 can be written using the WRSR command.

Write Protection

When \overline{WP} input is low all write operations to the memory array and Status Register are inhibited. \overline{WP} going low while \overline{CS} is still low will interrupt a write operation. If the internal write cycle has already been initiated, \overline{WP} going low will have no effect on any write operation to the Status Register or memory array. The \overline{WP} input timing is shown in Figure 8.

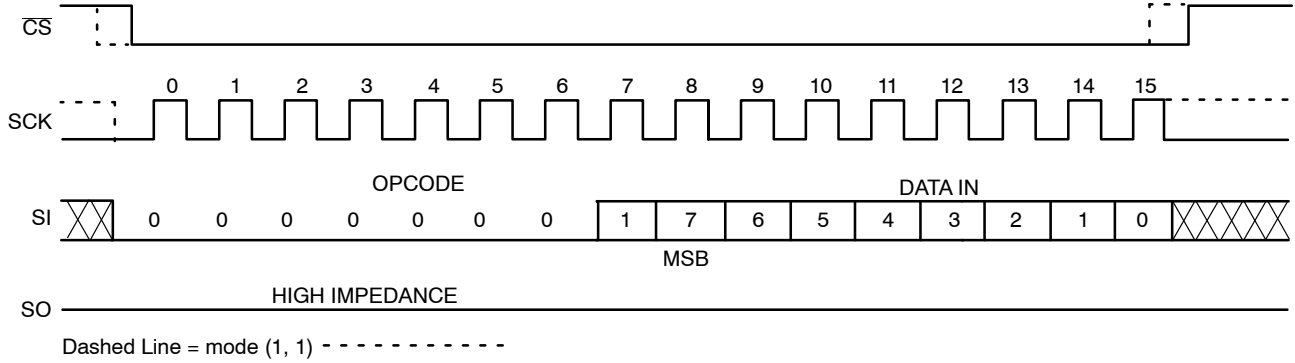

Figure 7. WRSR Timing

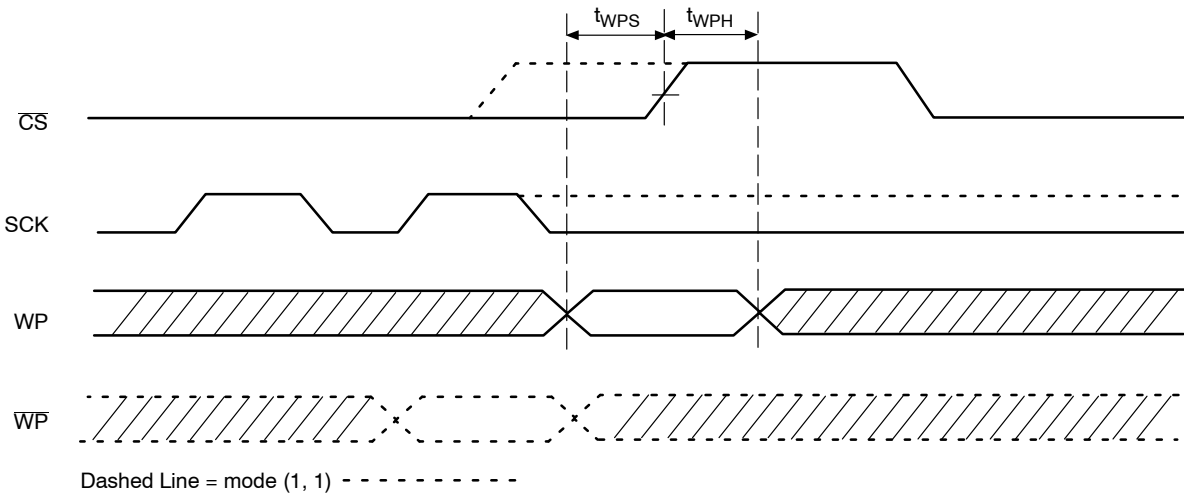

Figure 8. \overline{WP} Timing

CAT25010, CAT25020, CAT25040

READ OPERATIONS

Read from Memory Array

To read from memory, the host sends a READ instruction followed by a 8-bit address (for the CAT25040, bit 3 of the read instruction opcode contains A8 address bit).

After receiving the last address bit, the CAT25010/20/40 will respond by shifting out data on the SO pin (as shown in Figure 9). Sequentially stored data can be read out by simply continuing to run the clock. The internal address pointer is automatically incremented to the next higher address as data is shifted out. After reaching the highest memory address, the address counter “rolls over” to the lowest memory address, and the read cycle can be continued indefinitely. The read operation is terminated by taking CS high.

Read Status Register

To read the status register, the host simply sends a RDSR command. After receiving the last bit of the command, the CAT25010/20/40 will shift out the contents of the status register on the SO pin (Figure 10). The status register may be read at any time, including during an internal write cycle.

While the internal write cycle is in progress, the RDSR command will output the full content of the status register (New product, Rev. E) or the RDY (Ready) bit only (i.e., data out = FFh) for previous product revisions C, D (Mature product). For easy detection of the internal write cycle completion, both during writing to the memory array and to the status register, we recommend sampling the RDY bit only through the polling routine. After detecting the RDY bit “0”, the next RDSR instruction will always output the expected content of the status register.

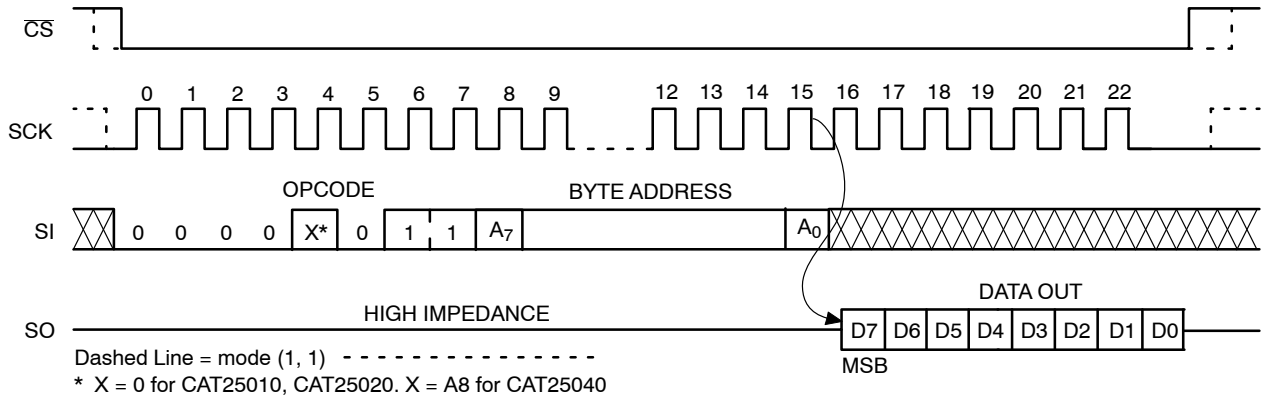

Figure 9. READ Timing

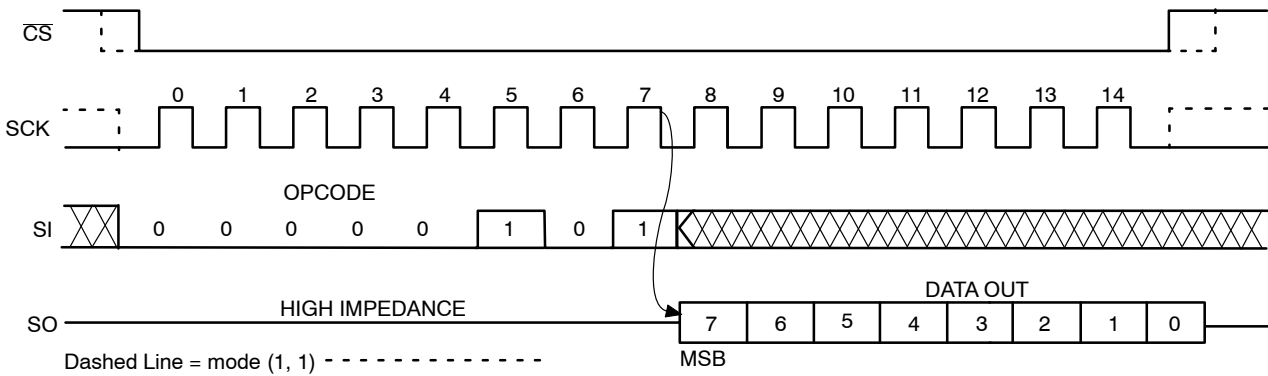

Figure 10. RDSR Timing

CAT25010, CAT25020, CAT25040

Hold Operation

The $\overline{\text{HOLD}}$ input can be used to pause communication between host and CAT25010/20/40. To pause, $\overline{\text{HOLD}}$ must be taken low while SCK is low (Figure 11). During the hold condition the device must remain selected ($\overline{\text{CS}}$ low). During the pause, the data output pin (SO) is tri-stated (high impedance) and SI transitions are ignored. To resume communication, $\overline{\text{HOLD}}$ must be taken high while SCK is low.

Design Considerations

The CAT25010/20/40 devices incorporate Power-On Reset (POR) circuitry which protects the internal logic against powering up in the wrong state. The device will power up into Standby mode after V_{CC} exceeds the POR trigger level and will power down into Reset mode when

V_{CC} drops below the POR trigger level. This bi-directional POR behavior protects the device against 'brown-out' failure following a temporary loss of power.

The CAT25010/20/40 device powers up in a write disable state and in a low power standby mode. A WREN instruction must be issued prior to any writes to the device.

After power up, the $\overline{\text{CS}}$ pin must be brought low to enter a ready state and receive an instruction. After a successful byte/page write or status register write, the device goes into a write disable mode. The $\overline{\text{CS}}$ input must be set high after the proper number of clock cycles to start the internal write cycle. Access to the memory array during an internal write cycle is ignored and programming is continued. Any invalid op-code will be ignored and the serial output pin (SO) will remain in the high impedance state.

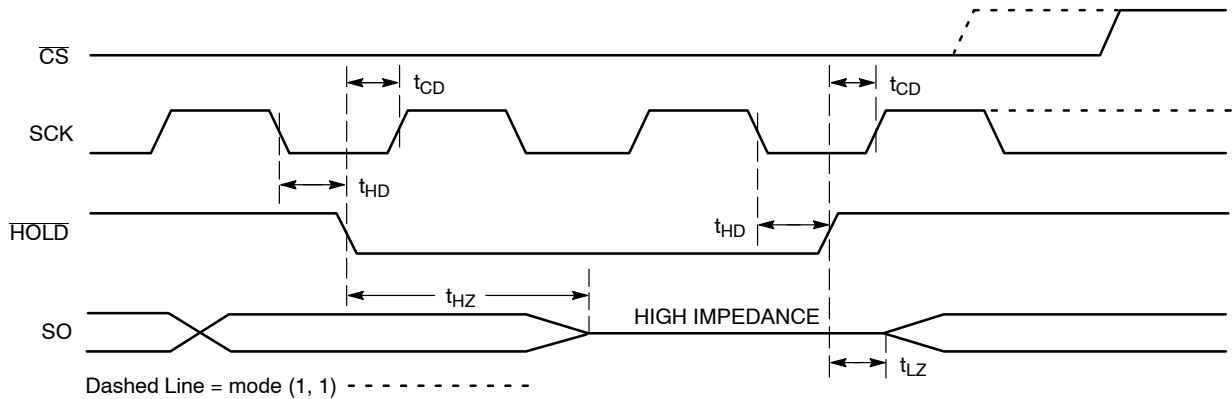
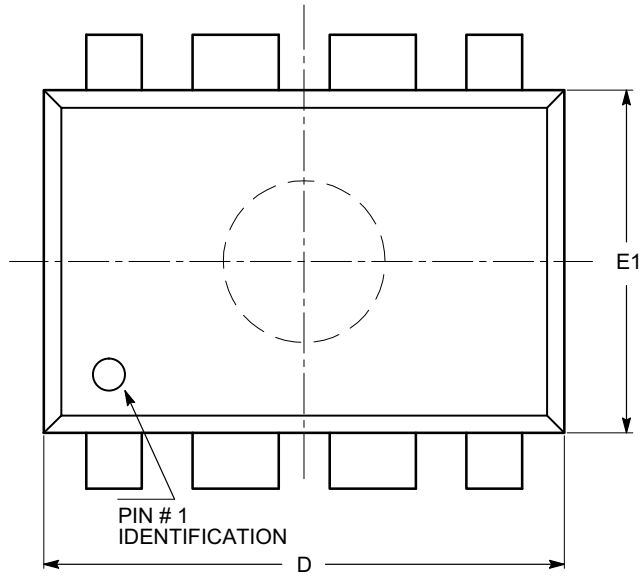

Figure 11. $\overline{\text{HOLD}}$ Timing

CAT25010, CAT25020, CAT25040

PACKAGE DIMENSIONS

PDIP-8, 300 mils
CASE 646AA-01
ISSUE A



SYMBOL	MIN	NOM	MAX
A			5.33
A1	0.38		
A2	2.92	3.30	4.95
b	0.36	0.46	0.56
b2	1.14	1.52	1.78
c	0.20	0.25	0.36
D	9.02	9.27	10.16
E	7.62	7.87	8.25
E1	6.10	6.35	7.11
e	2.54 BSC		
eB	7.87		10.92
L	2.92	3.30	3.80

TOP VIEW

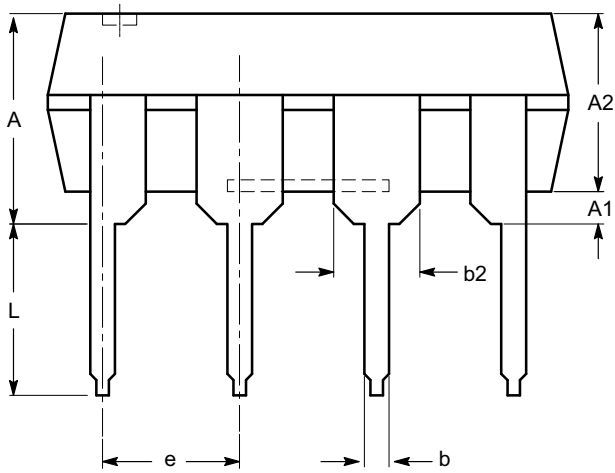

SIDE VIEW

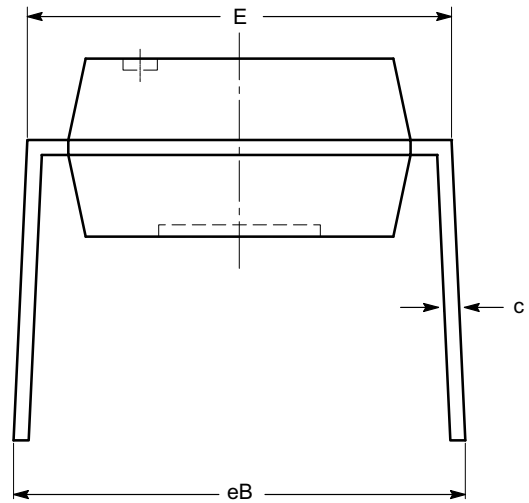

END VIEW

Notes:

- (1) All dimensions are in millimeters.
- (2) Complies with JEDEC MS-001.

CAT25010, CAT25020, CAT25040

PACKAGE DIMENSIONS

SOIC 8, 150 mils
CASE 751BD-01
ISSUE O

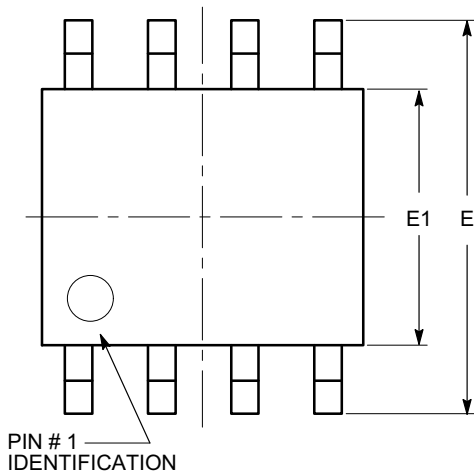

TOP VIEW

SYMBOL	MIN	NOM	MAX
A	1.35		1.75
A1	0.10		0.25
b	0.33		0.51
c	0.19		0.25
D	4.80		5.00
E	5.80		6.20
E1	3.80		4.00
e	1.27 BSC		
h	0.25		0.50
L	0.40		1.27
θ	0°		8°

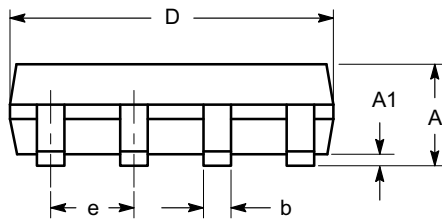

SIDE VIEW

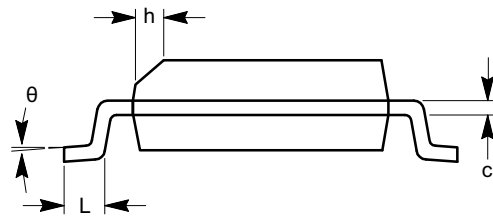

END VIEW

Notes:

- (1) All dimensions are in millimeters. Angles in degrees.
- (2) Complies with JEDEC MS-012.

CAT25010, CAT25020, CAT25040

PACKAGE DIMENSIONS

TSSOP8, 4.4x3
CASE 948AL-01
ISSUE O

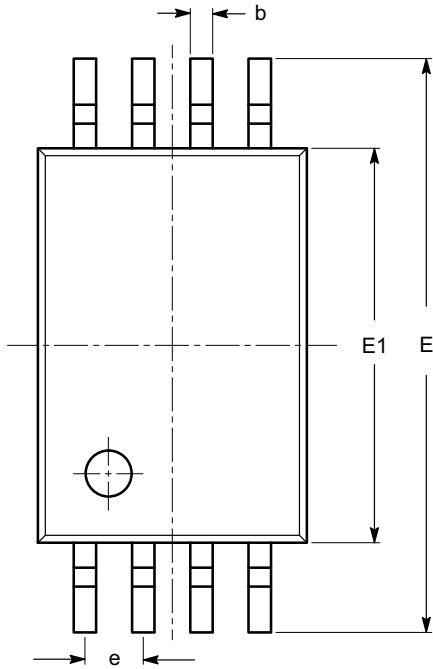

SYMBOL	MIN	NOM	MAX
A			1.20
A1	0.05		0.15
A2	0.80	0.90	1.05
b	0.19		0.30
c	0.09		0.20
D	2.90	3.00	3.10
E	6.30	6.40	6.50
E1	4.30	4.40	4.50
e	0.65 BSC		
L	1.00 REF		
L1	0.50	0.60	0.75
θ	0°		8°

TOP VIEW

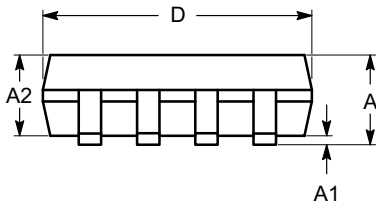

SIDE VIEW

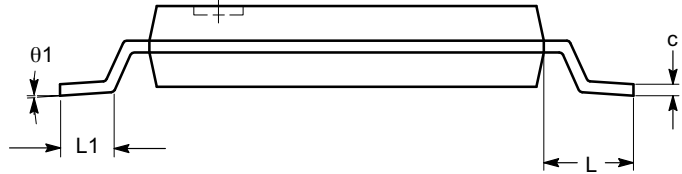

END VIEW

Notes:

- (1) All dimensions are in millimeters. Angles in degrees.
- (2) Complies with JEDEC MO-153.

CAT25010, CAT25020, CAT25040

PACKAGE DIMENSIONS

TDFN8, 2x3
CASE 511AK-01
ISSUE A

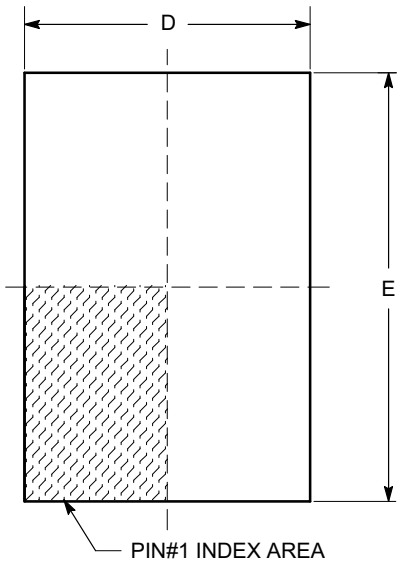

TOP VIEW

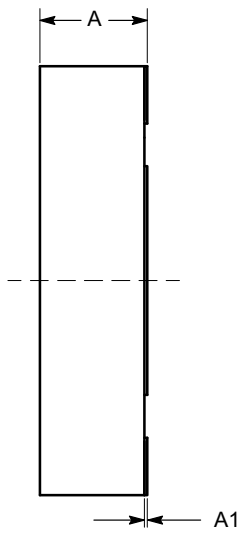

SIDE VIEW

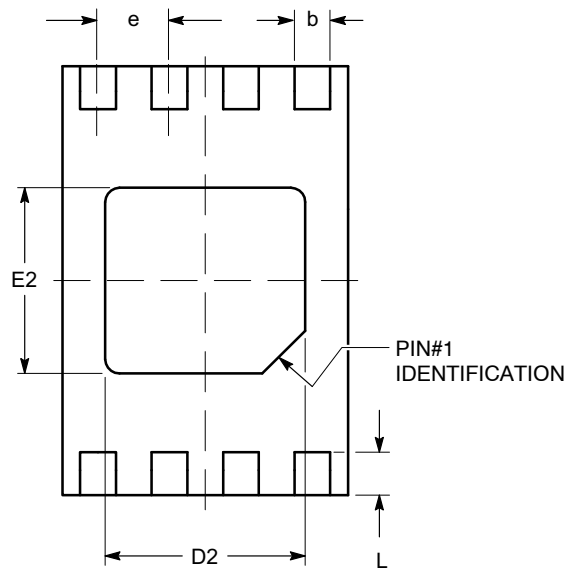

BOTTOM VIEW

SYMBOL	MIN	NOM	MAX
A	0.70	0.75	0.80
A1	0.00	0.02	0.05
A2	0.45	0.55	0.65
A3	0.20 REF		
b	0.20	0.25	0.30
D	1.90	2.00	2.10
D2	1.30	1.40	1.50
E	2.90	3.00	3.10
E2	1.20	1.30	1.40
e	0.50 TYP		
L	0.20	0.30	0.40

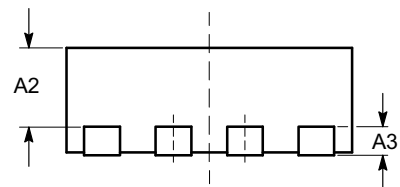

FRONT VIEW

Notes:

- (1) All dimensions are in millimeters.
- (2) Complies with JEDEC MO-229.

CAT25010, CAT25020, CAT25040

PACKAGE DIMENSIONS

MSOP 8, 3x3
CASE 846AD-01
ISSUE O

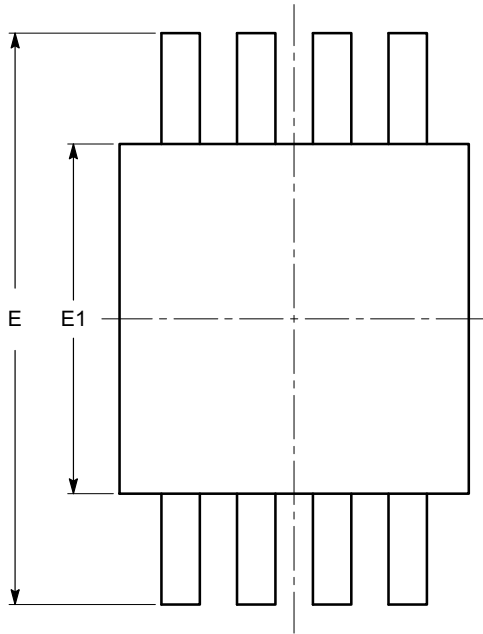

TOP VIEW

SYMBOL	MIN	NOM	MAX
A			1.10
A1	0.05	0.10	0.15
A2	0.75	0.85	0.95
b	0.22		0.38
c	0.13		0.23
D	2.90	3.00	3.10
E	4.80	4.90	5.00
E1	2.90	3.00	3.10
e	0.65 BSC		
L	0.40	0.60	0.80
L1	0.95 REF		
L2	0.25 BSC		
θ	0°		6°

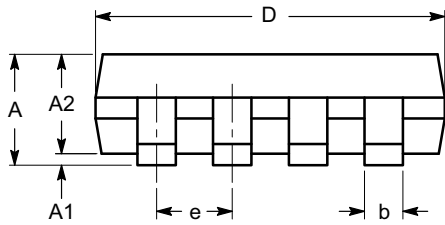

SIDE VIEW

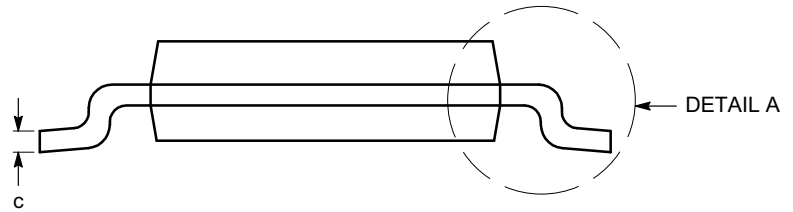

END VIEW

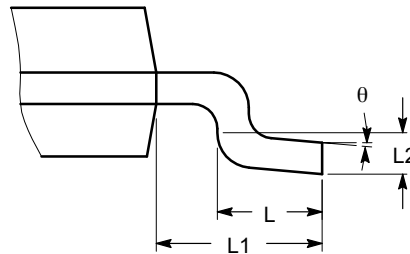

DETAIL A

Notes:

- (1) All dimensions are in millimeters. Angles in degrees.
- (2) Complies with JEDEC MO-187.

CAT25010, CAT25020, CAT25040

PACKAGE DIMENSIONS

UDFN8, 2x3 EXTENDED PAD
CASE 517AZ-01
ISSUE O

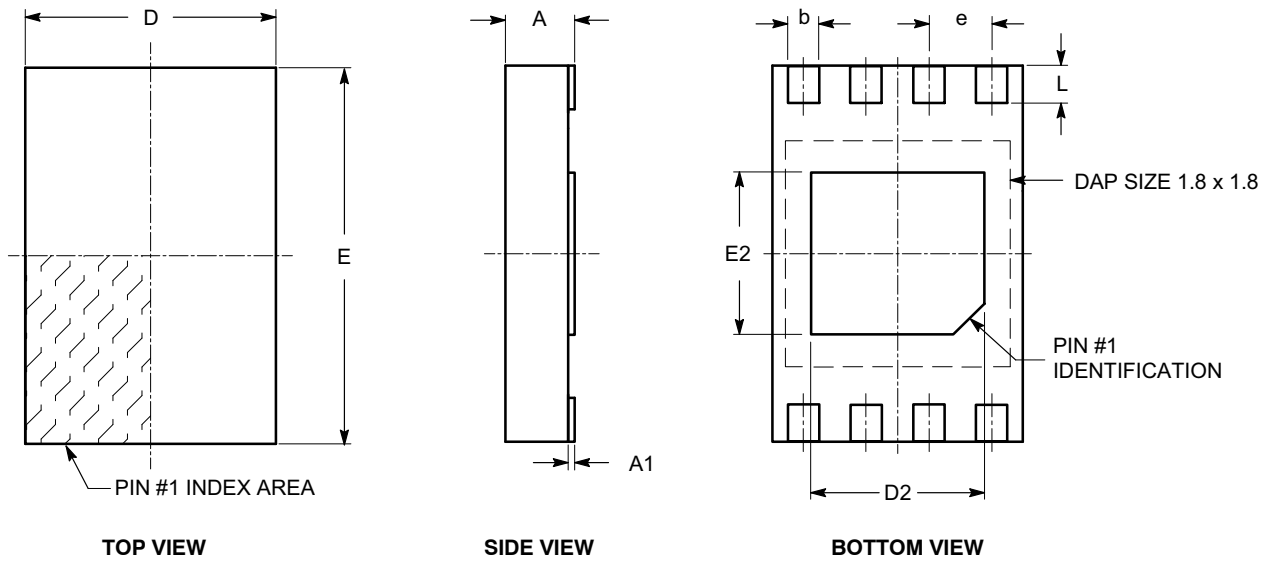

SYMBOL	MIN	NOM	MAX
A	0.45	0.50	0.55
A1	0.00	0.02	0.05
A3	0.127 REF		
b	0.20	0.25	0.30
D	1.95	2.00	2.05
D2	1.35	1.40	1.45
E	2.95	3.00	3.05
E2	1.25	1.30	1.35
e	0.50 REF		
L	0.25	0.30	0.35

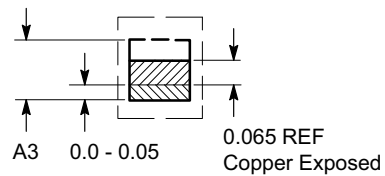
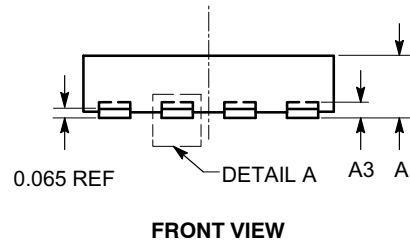

Notes:

- (1) All dimensions are in millimeters.
- (2) Refer JEDEC MO-236/MO-252.

CAT25010, CAT25020, CAT25040

ORDERING INFORMATION

Device Order Number	Specific Device Marking (Note 14)	Package Type	Temperature Range	Lead Finish	Shipping
CAT25010HU4E-GT3	S0U	UDFN8-EP	-40°C to +125°C	NiPdAu	3,000 Units / Tape & Reel
CAT25010HU4I-GT3	S0U	UDFN8-EP	-40°C to +85°C	NiPdAu	3,000 Units / Tape & Reel
CAT25010LE-G	25010E	PDIP-8	-40°C to +125°C	NiPdAu	Tube, 50 Units
CAT25010LI-G	25010E	PDIP-8	-40°C to +85°C	NiPdAu	Tube, 50 Units
CAT25010VE-G	25010E	SOIC-8, JEDEC	-40°C to +125°C	NiPdAu	Tube, 100 Units
CAT25010VE-GT3	25020E	SOIC-8, JEDEC	-40°C to +125°C	NiPdAu	3,000 Units / Tape & Reel
CAT25010VI-G	25010E	SOIC-8, JEDEC	-40°C to +125°C	NiPdAu	Tube, 100 Units
CAT25010VI-GT3	25020E	SOIC-8, JEDEC	-40°C to +125°C	NiPdAu	3,000 Units / Tape & Reel
CAT25010VP2E-GT3 (Note 17)	S0T	TDFN-8	-40°C to +125°C	NiPdAu	3,000 Units / Tape & Reel
CAT25010VP2I-GT3 (Note 17)	S0T	TDFN-8	-40°C to +85°C	NiPdAu	3,000 Units / Tape & Reel
CAT25010YE-G	S01E	TSSOP-8	-40°C to +125°C	NiPdAu	Tube, 100 Units
CAT25010YE-GT3	S01E	TSSOP-8	-40°C to +125°C	NiPdAu	3,000 Units / Tape & Reel
CAT25010YI-G	S01E	TSSOP-8	-40°C to +85°C	NiPdAu	Tube, 100 Units
CAT25010YI-GT3	S01E	TSSOP-8	-40°C to +85°C	NiPdAu	3,000 Units / Tape & Reel
CAT25010ZE-GT3	S0	MSOP-8	-40°C to +125°C	NiPdAu	3,000 Units / Tape & Reel
CAT25010ZI-G	S0	MSOP-8	-40°C to +85°C	NiPdAu	Tube, 96 Units
CAT25010ZI-GT3	S0	MSOP-8	-40°C to +85°C	NiPdAu	3,000 Units / Tape & Reel
CAT25020HU4E-GT3	S1U	UDFN8-EP	-40°C to +125°C	NiPdAu	3,000 Units / Tape & Reel
CAT25020HU4I-GT3	S1U	UDFN8-EP	-40°C to +85°C	NiPdAu	3,000 Units / Tape & Reel
CAT25020LI-G	25020E	PDIP-8	-40°C to +85°C	NiPdAu	Tube, 50 Units
CAT25020VE-GT3	25020E	SOIC-8, JEDEC	-40°C to +125°C	NiPdAu	3,000 Units / Tape & Reel
CAT25020VI-G	25020E	SOIC-8, JEDEC	-40°C to +125°C	NiPdAu	Tube, 100 Units
CAT25020VI-GT3	25020E	SOIC-8, JEDEC	-40°C to +125°C	NiPdAu	3,000 Units / Tape & Reel
CAT25020VP2E-GT3 (Note 17)	S1T	TDFN-8	-40°C to +125°C	NiPdAu	3,000 Units / Tape & Reel
CAT25020VP2I-GT3 (Note 17)	S1T	TDFN-8	-40°C to +85°C	NiPdAu	3,000 Units / Tape & Reel
CAT25020YE-GT3	S02E	TSSOP-8	-40°C to +125°C	NiPdAu	3,000 Units / Tape & Reel
CAT25020YI-G	S02E	TSSOP-8	-40°C to +85°C	NiPdAu	Tube, 100 Units
CAT25020YI-GT3	S02E	TSSOP-8	-40°C to +85°C	NiPdAu	3,000 Units / Tape & Reel
CAT25020ZE-GT3	S1	MSOP-8	-40°C to +125°C	NiPdAu	3,000 Units / Tape & Reel
CAT25020ZI-GT3	S1	MSOP-8	-40°C to +85°C	NiPdAu	3,000 Units / Tape & Reel

14. Specific Device Marking shows the first row top marking for new product (Revision E).

15. All packages are RoHS-compliant (Lead-free, Halogen-free).

16. The standard lead finish is NiPdAu.

17. Not recommended for new designs.

18. For information on tape and reel specifications, including part orientation and tape sizes, please refer to our Tape and Reel Packaging Specifications Brochure, BRD8011/D.

19. For detailed information and a breakdown of device nomenclature and numbering systems, please see the ON Semiconductor Device Nomenclature document, TND310/D, available at www.onsemi.com

CAT25010, CAT25020, CAT25040

ORDERING INFORMATION

Device Order Number	Specific Device Marking (Note 14)	Package Type	Temperature Range	Lead Finish	Shipping
CAT25040HU4E-GT3	S2U	UDFN8-EP	-40°C to +125°C	NiPdAu	3,000 Units / Tape & Reel
CAT25040HU4I-GT3	S2U	UDFN8-EP	-40°C to +85°C	NiPdAu	3,000 Units / Tape & Reel
CAT25040LE-G	25040E	PDIP-8	-40°C to +125°C	NiPdAu	Tube, 50 Units
CAT25040LI-G	25040E	PDIP-8	-40°C to +85°C	NiPdAu	Tube, 50 Units
CAT25040VE-G	25040E	SOIC-8, JEDEC	-40°C to +125°C	NiPdAu	Tube, 100 Units
CAT25040VE-GT3	25040E	SOIC-8, JEDEC	-40°C to +125°C	NiPdAu	3,000 Units / Tape & Reel
CAT25040VI-G	25040E	SOIC-8, JEDEC	-40°C to +125°C	NiPdAu	Tube, 100 Units
CAT25040VI-GT3	25040E	SOIC-8, JEDEC	-40°C to +125°C	NiPdAu	3,000 Units / Tape & Reel
CAT25040VP2E-GT3 (Note 17)	S2T	TDFN-8	-40°C to +125°C	NiPdAu	3,000 Units / Tape & Reel
CAT25040VP2I-GT3 (Note 17)	S2T	TDFN-8	-40°C to +85°C	NiPdAu	3,000 Units / Tape & Reel
CAT25040YE-GT3	S04E	TSSOP-8	-40°C to +125°C	NiPdAu	3,000 Units / Tape & Reel
CAT25040YI-G	S04E	TSSOP-8	-40°C to +85°C	NiPdAu	Tube, 100 Units
CAT25040YI-GT3	S04E	TSSOP-8	-40°C to +85°C	NiPdAu	3,000 Units / Tape & Reel
CAT25040ZE-GT3	S2	MSOP-8	-40°C to +125°C	NiPdAu	3,000 Units / Tape & Reel
CAT25040ZI-GT3	S2	MSOP-8	-40°C to +85°C	NiPdAu	3,000 Units / Tape & Reel

14. Specific Device Marking shows the first row top marking for new product (Revision E).

15. All packages are RoHS-compliant (Lead-free, Halogen-free).

16. The standard lead finish is NiPdAu.

17. Not recommended for new designs.

18. For information on tape and reel specifications, including part orientation and tape sizes, please refer to our Tape and Reel Packaging Specifications Brochure, BRD8011/D.

19. For detailed information and a breakdown of device nomenclature and numbering systems, please see the ON Semiconductor Device Nomenclature document, TND310/D, available at www.onsemi.com

ON Semiconductor and  are registered trademarks of Semiconductor Components Industries, LLC (SCILLC). SCILLC reserves the right to make changes without further notice to any products herein. SCILLC makes no warranty, representation or guarantee regarding the suitability of its products for any particular purpose, nor does SCILLC assume any liability arising out of the application or use of any product or circuit, and specifically disclaims any and all liability, including without limitation special, consequential or incidental damages. "Typical" parameters which may be provided in SCILLC data sheets and/or specifications can and do vary in different applications and actual performance may vary over time. All operating parameters, including "Typicals" must be validated for each customer application by customer's technical experts. SCILLC does not convey any license under its patent rights nor the rights of others. SCILLC products are not designed, intended, or authorized for use as components in systems intended for surgical implant into the body, or other applications intended to support or sustain life, or for any other application in which the failure of the SCILLC product could create a situation where personal injury or death may occur. Should Buyer purchase or use SCILLC products for any such unintended or unauthorized application, Buyer shall indemnify and hold SCILLC and its officers, employees, subsidiaries, affiliates, and distributors harmless against all claims, costs, damages, and expenses, and reasonable attorney fees arising out of, directly or indirectly, any claim of personal injury or death associated with such unintended or unauthorized use, even if such claim alleges that SCILLC was negligent regarding the design or manufacture of the part. SCILLC is an Equal Opportunity/Affirmative Action Employer. This literature is subject to all applicable copyright laws and is not for resale in any manner.

PUBLICATION ORDERING INFORMATION

LITERATURE FULFILLMENT:

Literature Distribution Center for ON Semiconductor
P.O. Box 5163, Denver, Colorado 80217 USA
Phone: 303-675-2175 or 800-344-3860 Toll Free USA/Canada
Fax: 303-675-2176 or 800-344-3867 Toll Free USA/Canada
Email: orderlit@onsemi.com

N. American Technical Support: 800-282-9855 Toll Free
USA/Canada
Europe, Middle East and Africa Technical Support:
Phone: 421 33 790 2910
Japan Customer Focus Center
Phone: 81-3-5817-1050

ON Semiconductor Website: www.onsemi.com

Order Literature: <http://www.onsemi.com/orderlit>

For additional information, please contact your local Sales Representative