

MC33567

Dual Linear Controller for High Current Voltage Regulation

The MC33567 Dual Linear Power Supply Controller is designed to facilitate power management for motherboard applications where reliable regulation of high current supply planes is required. It provides the Drive, Sense and Control signals to interface two external, N-channel MOSFETs for regulating two different supply planes. Undervoltage short circuit detection places the operation of the system into a protected mode pending removal of the short.

Features

- Two Independent Regulated Supplies
- MC33567-1: 1.515 V – Supply for GTL and AGP Planes
1.818 V – Supply for I/O Plane and Memory Termination
- MC33567-2: Dual 2.525 V Supplies for Clock and Memory
- MC33567-3: 2.3 V – Voltage Supply
1.2 V – Voltage Supply
- Undervoltage Short Circuit Protection
- Supply Undervoltage Detection
- Drive Capability for N-Channel MOSFETs
- Bypass Function for 3.3 V AGP Card Detection
- Pb-Free Package May be Available. The G-Suffix Denotes a Pb-Free Lead Finish

Applications

- Motherboards
- Dual Power Supplies

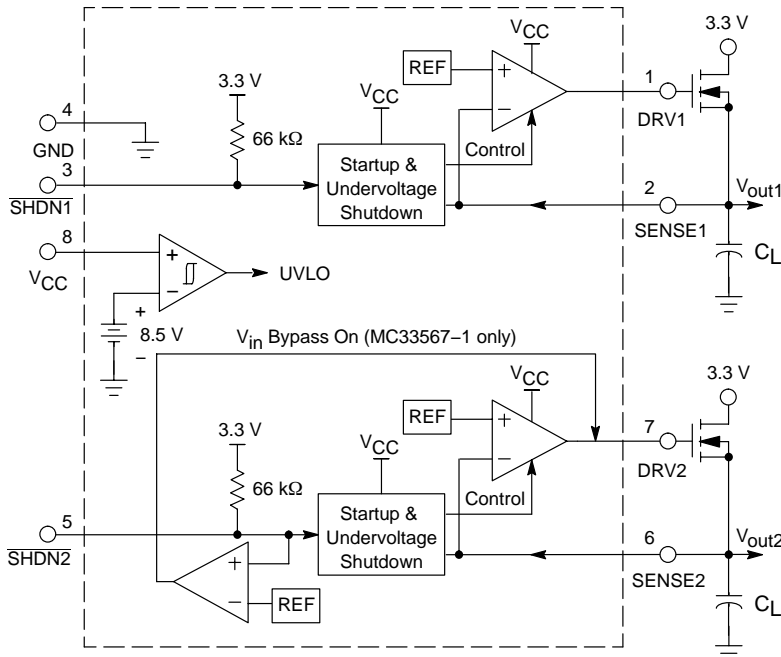

Figure 1. Simplified Block Diagram



ON Semiconductor®

<http://onsemi.com>

MARKING DIAGRAM

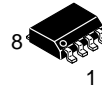

SO-8
D SUFFIX
CASE 751

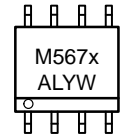

x = 1, 2 or 3
A = Assembly Location
L = Wafer Lot
Y = Year
W = Work Week

PIN CONNECTIONS

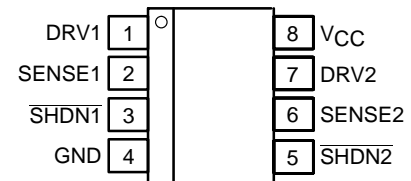

ORDERING INFORMATION

See detailed ordering and shipping information in the package dimensions section on page 11 of this data sheet.

MC33567

PIN ASSIGNMENTS AND FUNCTIONS

PIN #	PIN NAME	PIN DESCRIPTION
1	DRV1	Gate 1 drive. Is internally clamped to ground in power down mode.
2	SENSE1	Sense 1 line. Sense load voltage and provides feedback to regulator.
3	$\overline{\text{SHDN1}}$	TTL high level turns on regulation for gate 1. (Internal pull-up to 3.3 V)
4	GND	
5	$\overline{\text{SHDN2}}$	TTL high level turns on regulation for gate 2. (Internal pull-up to 3.3 V)
6	SENSE2	Sense 2 line. Sense load voltage and provides feedback to regulator.
7	DRV2	Gate 2 drive. Saturates external FET in bypass mode (MC33567-1 only). Is internally clamped to ground in power down mode.
8	VCC	Supply voltage for operation and gate drive output – typically 12 V.

MAXIMUM RATINGS (Notes 1, 2 and 3)

Rating	Symbol	Value	Unit
Supply Voltage	VCC	12.5	Vdc
SHUTDOWN Voltage	$V_{\overline{\text{SHDN}}}$	VCC	Vdc
Operating Ambient Temperature	T _A	0 to 80	°C
Operating Junction Temperature	T _J	-5.0 to 125	°C
Lead Temperature (Soldering, 10 seconds)	T _L	300	°C
Storage Temperature Range	T _{stg}	-55 to 150	°C
Package Thermal Resistance, Junction to Ambient	R _{θJA} (Note 2)	159	°C/W
Thermal Resistance, Junction to Case	R _{θJC}	28	°C/W

1. ESD Ratings

ESD Machine Model protection up to 200 V, class B.

ESD Human Body Model protection up to 2000 V, class 2.

- Minimum pad test board with 5 MIL wide and 2.8 MIL thick copper traces 1 inch long.
- All characterizing done with MTD3055VL N-Channel MOSFETs.

MC33567

DC ELECTRICAL CHARACTERISTICS

($V_{CC} = 12\text{ V}$, $V_{\overline{SHDN}1} = V_{\overline{SHDN}2} = 2.0\text{ V}$, $T_A = 0^\circ\text{C}$ to 80°C , typical values shown are for $T_J = 25^\circ\text{C}$ unless otherwise noted.)

Characteristic	Symbol	Min	Typ	Max	Unit
Supply Voltage	V_{CC}	9.0	12	12.5	V
Quiescent Current $V_{\overline{SHDN}1} = V_{\overline{SHDN}2} = 0\text{ V}$ $V_{\overline{SHDN}1} = V_{\overline{SHDN}2} = 2.0\text{ V}$	I_{qL}	–	5.8	9.0	mA
	I_{qH}	–	6.3	10	

UNDERVOLTAGE LOCKOUT

Undervoltage Lockout Threshold Voltage (V_{CC} Increasing)	UVLO	7.0	8.5	9.0	V
Hysteresis Voltage (V_{CC} Decreasing)	UVLO _{v_{hys}}	0.2	0.5	0.9	V

DRIVE OUTPUTS

Drive Output Voltage (Gate to Ground)	V_{drv}	–	10.5	–	V
Drive Output Source Current ($T_J = 25^\circ\text{C}$)	I_{pkdrv}	10	20	30	mA
Gate Drive Output Sink Current ($V_{sense} = 0\text{ V}$, $T_J = 25^\circ\text{C}$)	I_{sink}	4.0	7.0	10	mA

SHUTDOWN INPUTS

Shutdown Threshold Voltage (Drive output on to off, ramp $V_{\overline{SHDN}}$ to 0 V)	\overline{SHDN}_{Vth}	0.8	1.13	1.3	V
Shutdown Threshold Hysteresis (Drive output off to on)	\overline{SHDN}_{hys}	50	130	200	mV
Shutdown Disable Time (Drive output on to off, ramp $V_{\overline{SHDN}}$ to 0 V)	\overline{SHDN}_{tdis}	–	0.5	2.0	μs
Shutdown Input Current ($V_{\overline{SHDN}} = 0\text{ V}$)	$I_{\overline{SHDN}}$	–	–50	–	μA

SHORT CIRCUIT

Short Circuit/Undervoltage Detect Threshold (Load current increased until output voltage drops activating hiccup mode)	SC _{uvd}	70	75	80	% V_{out}
Drive Output Response Time to short circuit (Ramp down V_{sense} to 0 V)	SC _{td}	200	325	500	μs
Drive Output On Time in hiccup mode ($V_{sense} = 0\text{ V}$)	SC _{ton}	0.5	0.97	1.5	ms
Drive Output Off Time in hiccup mode ($V_{sense} = 0\text{ V}$)	SC _{toff}	20	47.7	60	ms

OUTPUT REGULATION

Regulator Output Voltage ($V_{in} = 3.3\text{ V}$, $I_L = 5.0\text{ mA}$ to 1.3 A)					V
MC33567–1	Output 1	V_{out1}	1.773	1.818	1.864
	Output 2	V_{out2}	1.477	1.515	1.553
MC33567–2	Output 1	V_{out1}	2.462	2.525	2.589
	Output 2	V_{out2}	2.462	2.525	2.589
MC33567–3	Output 1	V_{out1}	2.243	2.300	2.358
	Output 2	V_{out2}	1.170	1.200	1.230
Output Voltage Regulation ($I_L = 5.0\text{ mA}$ to 1.3 A)	$V_{reg\%}$	–2.5	–	+2.5	%

OPERATING DESCRIPTION

Introduction

The MC33567 series is a family of Dual Linear FET Controllers designed for Power Management applications where high current, voltage regulation is needed. Some computer applications include:

- 1.2 V – Power Supply
- 1.515 V – AGP (Advanced Graphic Port) and GTL+ (Gunning Transistor Logic – Intel’s electrical bus technology)
- 1.818 V – I/O planes on motherboards
- 2.3 V – Power Supply
- 2.525 V – Clock and memory

The MC33567 provides tight output voltage regulation, (V_{out}), and incorporates individual \overline{SHDN} controls for each FET controller and voltage protection by sensing the output voltage.

Output:

The MC33567 provides tight output voltage regulation from one or two supply voltages using 2 external N-Channel MOSFETs. Each controller operates independently and regulates the output voltage to a predetermined level (1.2 V, 1.515 V, 1.818 V, 2.3 V or 2.525 V). In addition, regulator 2 of the MC33567-1 incorporates a V_{in} bypass mode on which the external FET is fully enhanced.

Shutdown:

The regulated outputs of the MC33567 can be disabled with the use of the \overline{SHDN} pin. It also determines the output voltage level. \overline{SHDN} can be controlled externally from board signals like the AGP or GTL+ as shown in Figure 3.

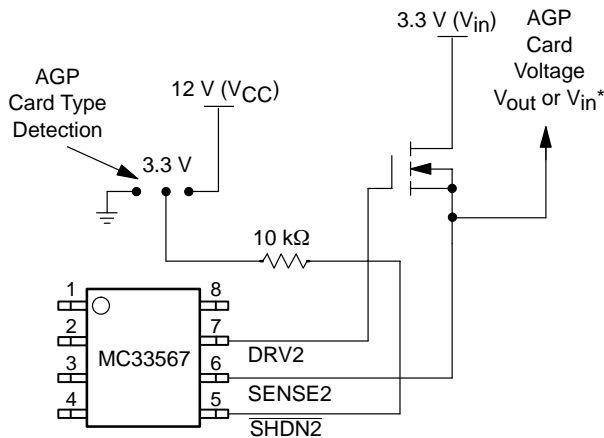

* V_{in} while on bypass mode (MC33567-1 only)

Figure 3. 1.5 V/3.3 V AGP Card Detection

Listed below are the \overline{SHDN} threshold voltage levels and the corresponding regulator output voltages:

1. If the \overline{SHDN} pin is left open, the output voltage is set to its regulated value.
2. If a voltage less than 0.8 V is applied to the \overline{SHDN} pin, the output voltage is set to 0 V.
3. If a voltage greater than 1.3 V and less than 4.1 V is applied to the \overline{SHDN} pin, the output voltage is set to its regulated voltage.
4. If the \overline{SHDN} voltage is pulled above 4.1 V, the MC33567 enters a V_{in} bypass mode. In this mode, the MOSFET is fully enhanced and the output voltage is the MOSFET drain voltage (V_{in}) minus the MOSFET drain-source on voltage $V_{DS(on)}$. This feature is only available on REGULATOR 2 of the MC33567-1.

Table 1 summarizes the output voltage options and its relationship with V_{SHDN} .

Table 1. Logic Table for \overline{SHDN} Pin

Device	V_{SHDN} (V)	V_{out} (V)
MC33567-1 REGULATOR 1	No Connect	1.818 V
	< 0.8 V	0 V
REGULATOR 2	> 1.3 V	1.818 V
	No Connect	1.515 V
	< 0.8 V	0 V
	$1.3 V < V_{SHDN} < 4.1 V$	1.515 V
	> 4.1 V	$V_{in} - V_{DS(on)}$ (Bypass Mode)
MC33567-2 REGULATOR 1 & REGULATOR 2	No Connect	2.525 V
	< 0.8 V	0 V
	> 1.3 V	2.525 V
MC33567-3 REGULATOR 1	No Connect	2.3 V
	< 0.8 V	0 V
REGULATOR 2	> 1.3 V	2.3 V
	No Connect	1.2 V
	< 0.8 V	0 V
	> 1.3 V	1.2 V

Undervoltage Detection:

If V_{out} drops below 75% of the regulated threshold for greater than 250 μs or a short circuit condition is present, that output will go into short circuit or Hiccup Mode. While in Hiccup mode, the output is turned ON for 1.0 ms and OFF for 40 ms for a duty cycle of 1:41 as shown in Figure 4. This mode will continue as long as the fault is present. Once the fault is removed, the regulator will resume normal operation.

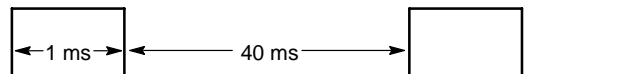

Figure 4. Hiccup Mode Duty Cycle

Sense:

If the load is located away from the regulator, the voltage drop on the connecting cable or trace can become significant. The MC33567 provides tight voltage load regulation with varying load currents using its SENSE feature. As shown in Figure 5, the MC33567 senses the voltage at the load and provides feedback to the regulator. The regulator voltage is then adjusted to compensate for the load changes. It is recommended that the SENSE connection be placed as close as possible to the load. Also, use a separate trace to connect the source of the N-channel MOSFET to the load to avoid interference or coupling with the SENSE signal. The use of the SENSE feature is required for correct device operation. If the SENSE pin is not connected to the load, the output will go into Hiccup mode.

The current into the SENSE pin is given by the following equation:

$$I_{SENSE} = 100 \mu A + \frac{V_{out}}{1.8 \text{ k}\Omega}$$

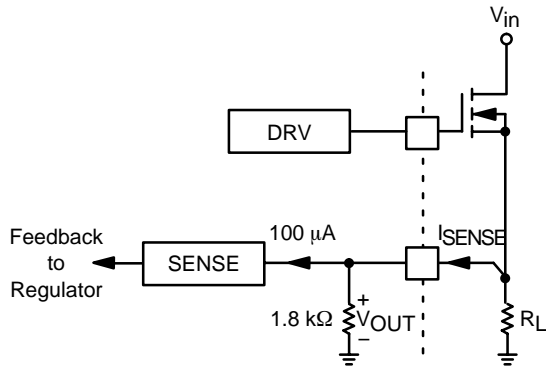

Figure 5. Voltage Regulation Using Sense Feature

N-Channel MOSFET Selection:

The MC33567 was characterized using ON Semiconductor’s MTD3055VL N-channel MOSFET. Other MOSFETs can be used with the MC33567 as long as power and stability requirements are met.

Power:

A MOSFET with a low drain-source on resistance ($R_{DS(on)}$) will insure the output voltage is not drastically reduced due to excessive voltage drop across the MOSFET.

The required $R_{DS(on)}$ can be calculated using the equation below:

$$R_{DS(on)} \leq 0.5 \frac{V_{in} - V_{out}}{I_{LOAD}}$$

where:

- V_{in} = Input Voltage, typically 3.3 V
- V_{out} = Regulator Output Voltage
(1.2 V, 1.515 V, 1.818 V, 2.3 V, or 2.525 V)
- I_{LOAD} = Load Current

A safety margin of 0.5 was added to account for $R_{DS(on)}$ variations over the operating temperature range.

Stability:

After evaluating the regulator, driver and load system using control theory it is demonstrated that the output capacitor, external driver gain and error amplifier gain bandwidth play an important role on the system stability. To insure system stability the following set of design guidelines should be followed:

$$C_i = C_{gs} + C_{gd}$$

$$\omega_f = \frac{1}{C_i \cdot R_o}$$

$$\omega_p = \left(\frac{1}{\omega_1} + \frac{1}{\omega_f} \right)^{-1}$$

$$\frac{1}{20 \cdot \left(1 + \frac{\omega_a}{(3 \cdot \omega_p)} \right)} \cdot \frac{1}{g_m} \leq R_s \leq \frac{(3 \cdot \omega_p)}{\omega_a} \cdot \frac{1}{g_m}$$

$$C_o \cdot R_s \geq 5 \cdot \left(\frac{1}{\omega_a} + \frac{1}{\omega_p} \right)$$

where:

- ω_f = Driver pole frequency
- C_i = Input and reverse transfer capacitance when device is off
- R_o = Regulator output resistance (50 Ω for the MC33567)
- ω_p = Secondary pole for open loop
- ω_a = Error amplifier gain bandwidth
- ω_1 = Error amp second pole (set $\omega_1 = \omega_a$, if not specified)
- R_s = Output capacitor ESR
- g_m = Maximum driver transconductance gain
- C_o = Output capacitance
- T = Overall loop response time

The output capacitor capacitance and ESR required for using the MTD3055VL as external driver are calculated as follows:

$$\omega_f = \frac{1}{C_i \cdot R_o} = \frac{1}{(1240 \text{ pF} + 600 \text{ pF}) \cdot (50 \Omega)} = 10.87 \text{ MHz}$$

$$\omega_p = \left(\frac{1}{\omega_1} + \frac{1}{\omega_f} \right)^{-1} = \left(\frac{1}{5 \text{ MHz}} + \frac{1}{10.87 \text{ MHz}} \right)^{-1}$$

$$= 3.42 \text{ MHz}$$

$$\frac{1}{20 \cdot \left(1 + \frac{\omega_a}{(3 \cdot \omega_p)} \right)} \cdot \frac{1}{9 \text{ m}} \leq R_s \leq \frac{(3 \cdot \omega_p)}{\omega_a} \cdot \frac{1}{9 \text{ m}}$$

$$\frac{1}{20 \cdot \left(1 + \frac{5 \text{ MHz}}{(3 \cdot 3.42 \text{ MHz})} \right)} \cdot \frac{1}{8.8 \text{ mhos}} \leq R_s \leq \frac{(3 \cdot 3.42 \text{ MHz})}{5 \text{ MHz}}$$

$$\cdot \frac{1}{8.8 \text{ mhos}}$$

$$3.8 \text{ m}\Omega \leq R_s \leq 233.2 \text{ m}\Omega$$

selecting an ESR of 30 mΩ, we have:

$$C_o \geq \frac{5}{R_s} \cdot \left(\frac{1}{\omega_a} + \frac{1}{\omega_p} \right)$$

$$C_o \geq \frac{5}{30 \text{ m}\Omega} \cdot \left(\frac{1}{5 \text{ MHz}} + \frac{1}{3.42 \text{ MHz}} \right)$$

$$C_o \geq 82.07 \mu\text{F}$$

100 μF is selected as it is an industry standard value. Please note that if the system is designed to work with several drivers, the system has to be designed around the driver with higher gain to insure stability for all of them.

The design guidelines discussed in this section are conservative enough that satisfactory results may be obtained with devices that lie just outside of these guidelines, although deviation from these guidelines will generally cause instability. For a more detailed analysis on linear regulators stability please refer to ON Semiconductor application note AND8037/D.

Adjustable Output Voltage:

The MC33567 will regulate V_{OUT} to its preset voltage level, referenced at the sense pin. However, other V_{OUT} levels can be obtained scaling the sense voltage. This is done using a resistive network between the load and the sense pin as shown in Figure 6.

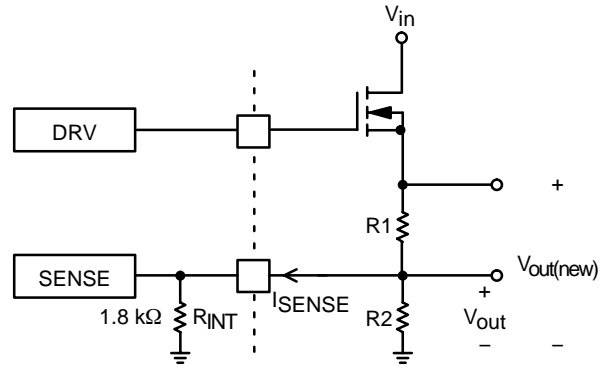

Figure 6. Output Voltage Scaling Using Resistive Network

The regulator will increase the load voltage until the SENSE pin voltage reaches the regulator voltage level, V_{OUT}. The new output voltage, V_{out(new)}, is calculated as follows:

$$V_{out(new)} = V_{out} + R_1 * \left(\frac{V_{out}}{R_2} + I_{SENSE} \right)$$

Please note that in this configuration R₂ and the sense internal resistor are in parallel. The parallel combination will reduce the effective resistance of R₂. If R₂ is in the range of R_{INT}, the parallel combination will be almost half of the original intended value of R₂. This will cause V_{out(new)} to be smaller than calculated using the above equation. This is avoided making R₂ as small as possible, probably in the range of 10 to 50 Ohms. V_{out(new)} is limited by the external driver drain current and its required Gate–Source voltage as well as the Drive Output Voltage, V_{drv}.

PCB Layout Guidelines

It is recommended that the MC33567 be placed as physically close as possible to the external series pass MOSFET transistors. Use short traces to minimize extraneous signals from being induced on the SENSE or DRV line. Also, avoid routing the SENSE line near the load and input current path, as well as the GND return current path to prevent signal coupling.

MC33567

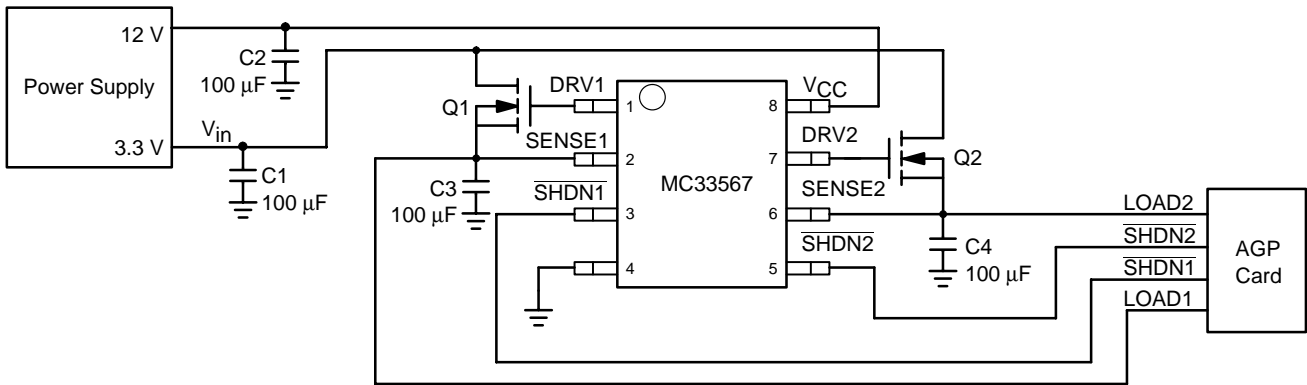

Figure 7. Application Block Diagram

Parts List

Qty	Reference	Part/Description	Vendor	Notes
4	C1, C2, C3, C4	100 µF Electrolytic Capacitor	Various	
1	U1	MC33567	ON Semiconductor	
2	Q1, Q2	MTD3055VL	ON Semiconductor	N-Channel MOSFET

MC33567 TYPICAL CHARACTERISTICS

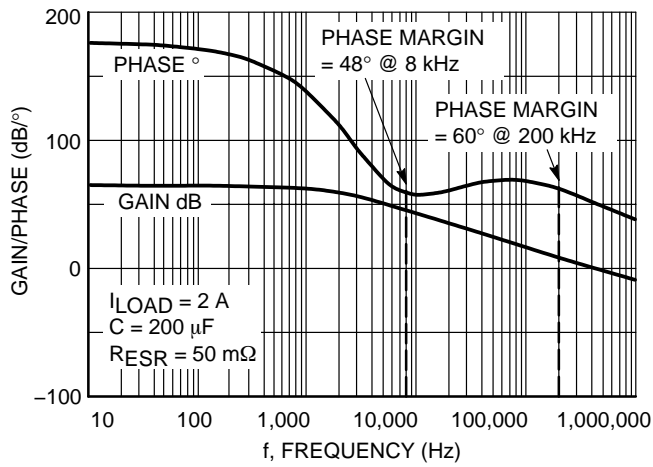

Figure 8. Gain-Phase Plot for Output Capacitor with 50 mΩ ESR

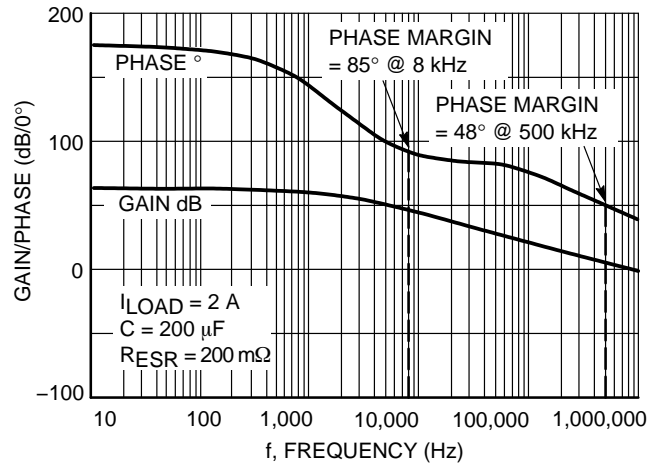

Figure 9. Gain-Phase Plot for Output Capacitor with 200 mΩ ESR

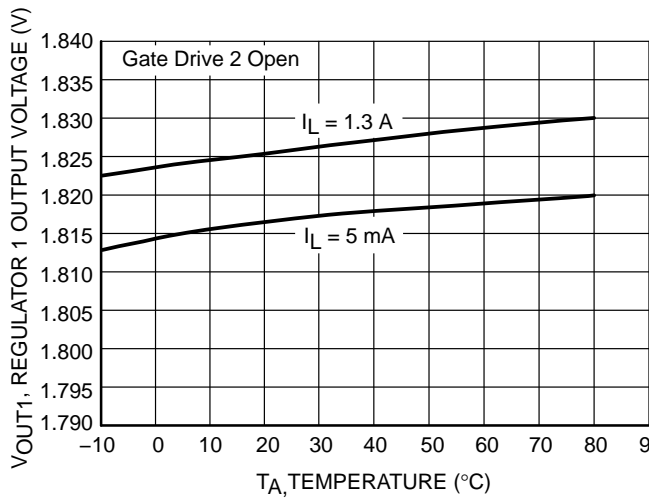

Figure 10. Regulator 1 (Suffix 1) Output Voltage vs. Ambient Temperature

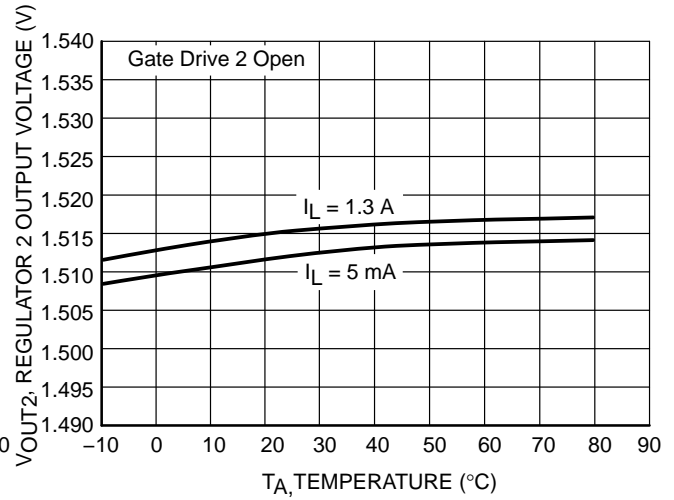

Figure 11. Regulator 2 (Suffix 1) Output Voltage vs. Ambient Temperature

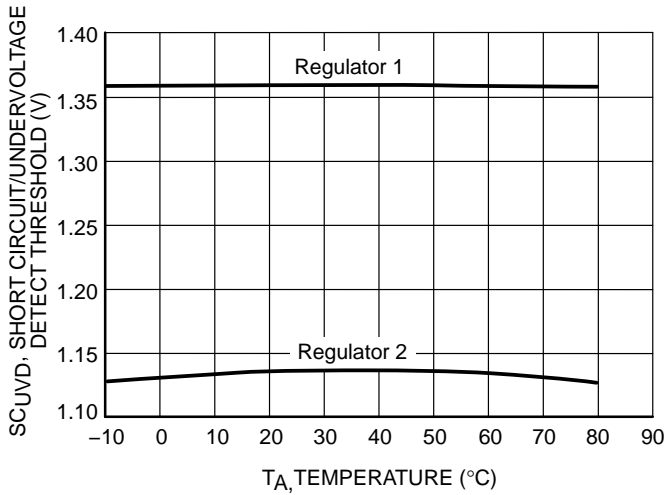

Figure 12. Short Circuit/Undervoltage Detect Threshold (Suffix 1) vs. Ambient Temperature

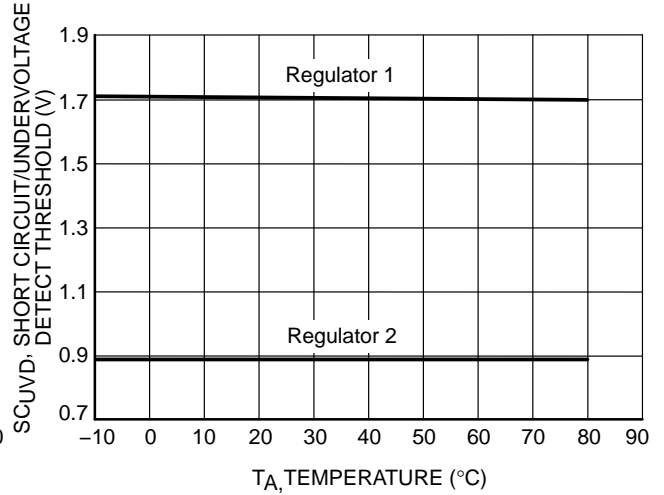

Figure 13. Short Circuit/Undervoltage Detect Threshold (Suffix 3) vs. Ambient Temperature

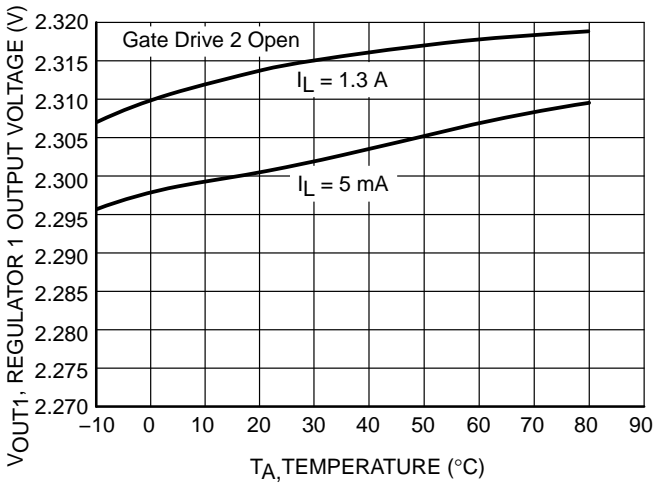

Figure 14. Regulator 1 (Suffix 3) Output Voltage vs. Ambient Temperature

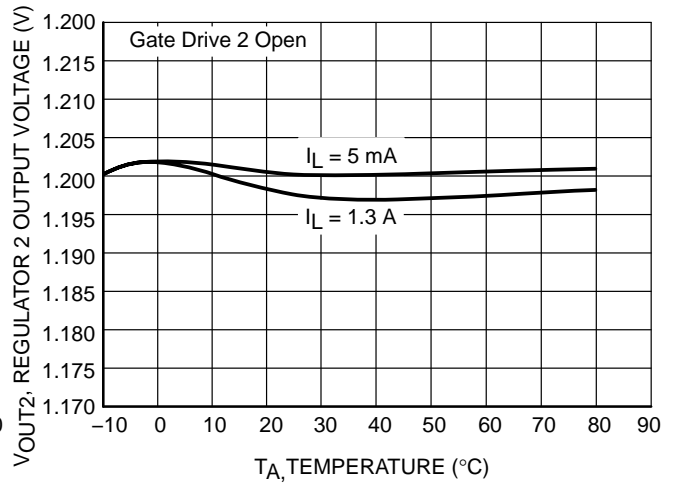

Figure 15. Regulator 2 (Suffix 3) Output Voltage vs. Ambient Temperature

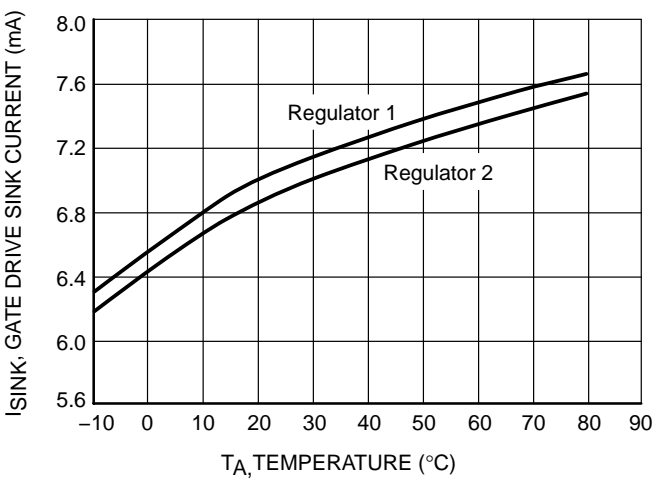

Figure 16. Gate Drive Sink Current vs. Ambient Temperature

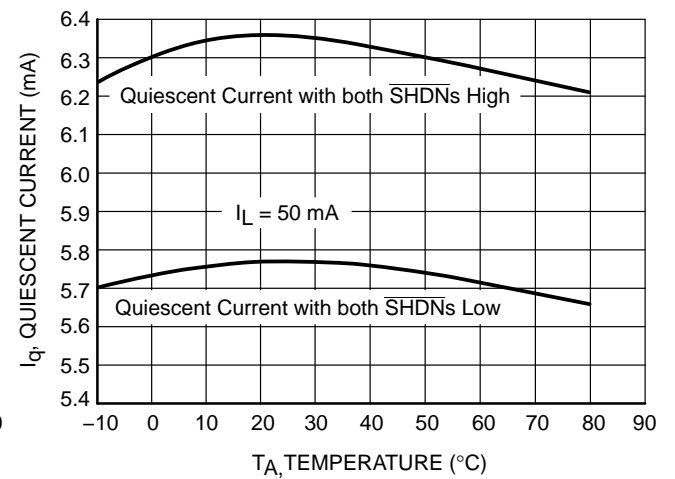

Figure 17. Quiescent Current vs. Ambient Temperature

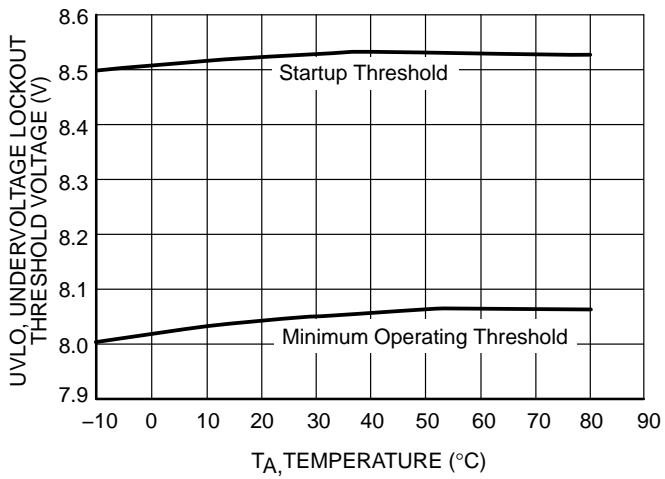

Figure 18. Undervoltage Lockout Threshold vs. Ambient Temperature

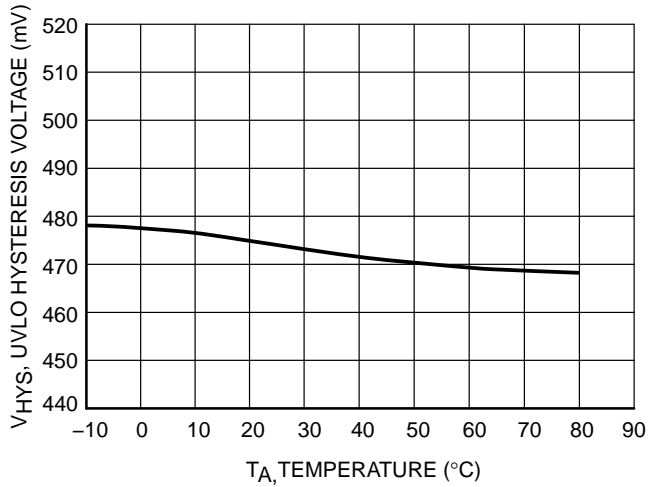

Figure 19. UVLO Hysteresis Voltage vs. Ambient Temperature

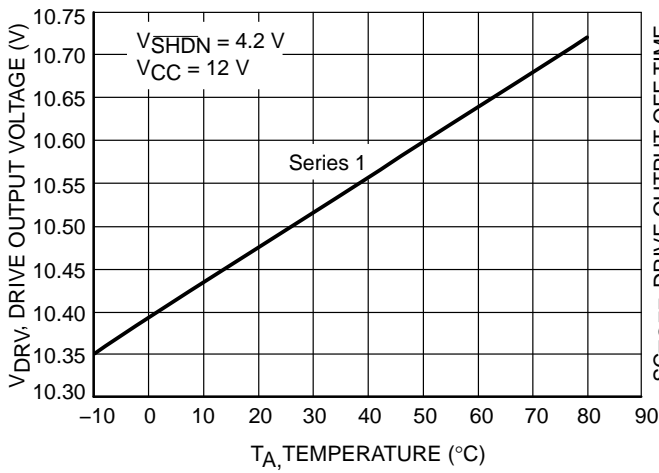

Figure 20. Regulator 2 Maximum Gate Voltage vs. Ambient Temperature

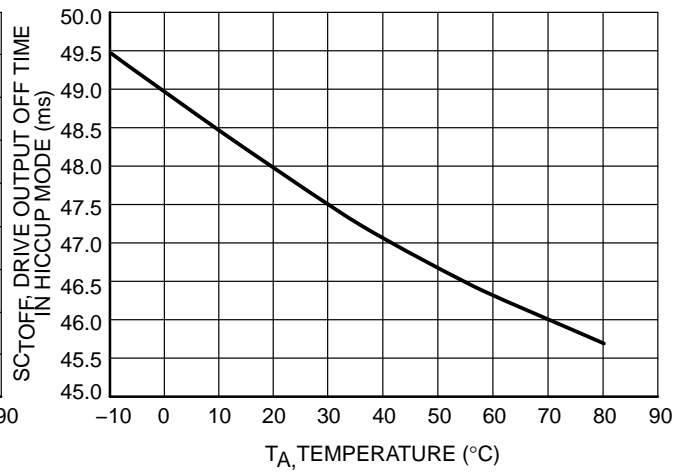

Figure 21. Drive Output Off Time in Hiccup Mode vs. Ambient Temperature

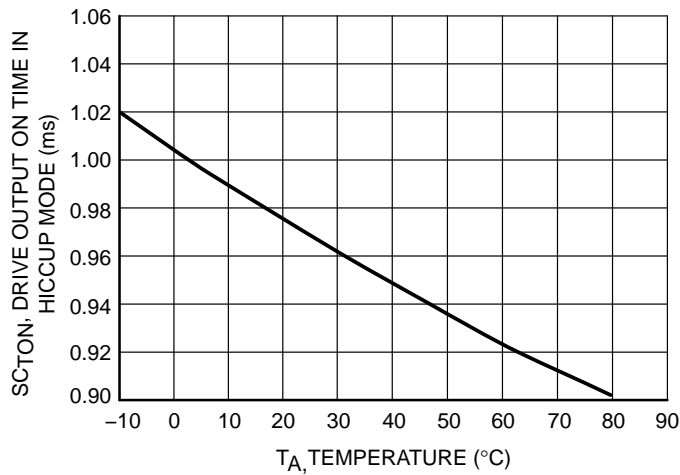

Figure 22. Drive Output On Time in Hiccup Mode vs. Ambient Temperature

MC33567

ORDERING INFORMATION

Device	V _{out1}	V _{out2}	Package	Shipping [†]
MC33567D-1	1.818 V	1.515 V or V _{in} *	SO-8	98 Units/Rail
MC33567D-1R2	1.818 V	1.515 V or V _{in} *	SO-8	2500/Tape & Reel
MC33567D-1R2G	1.818 V	1.515 V or V _{in} *	SO-8 (Pb-Free)	2500/Tape & Reel
MC33567D-2	2.525 V	2.525 V	SO-8	98 Units/Rail
MC33567D-2R2	2.525 V	2.525 V	SO-8	2500/Tape & Reel
MC33567D-3	2.300 V	1.200 V	SO-8	98 Units/Rail
MC33567D-3R2	2.300 V	1.200 V	SO-8	2500/Tape & Reel

[†]For information on tape and reel specifications, including part orientation and tape sizes, please refer to our Tape and Reel Packaging Specifications Brochure, BRD8011/D.

*While on bypass mode.

MC33567

PACKAGE DIMENSIONS

SO-8 D SUFFIX PLASTIC SOIC PACKAGE CASE 751-07 ISSUE AA

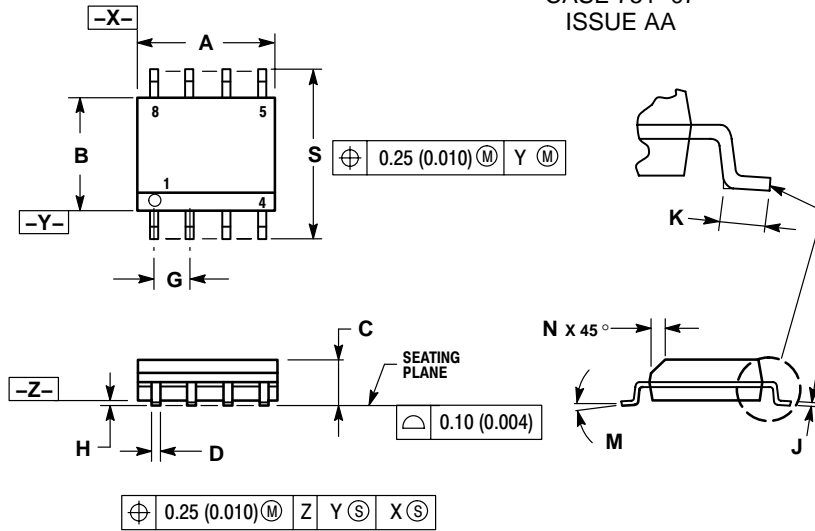

NOTES:

1. DIMENSIONING AND TOLERANCING PER ANSI Y14.5M, 1982.
2. CONTROLLING DIMENSION: MILLIMETER.
3. DIMENSION A AND B DO NOT INCLUDE MOLD PROTRUSION.
4. MAXIMUM MOLD PROTRUSION 0.15 (0.006) PER SIDE.
5. DIMENSION D DOES NOT INCLUDE DAMBAR PROTRUSION. ALLOWABLE DAMBAR PROTRUSION SHALL BE 0.127 (0.005) TOTAL IN EXCESS OF THE D DIMENSION AT MAXIMUM MATERIAL CONDITION.
6. 751-01 THRU 751-06 ARE OBSOLETE. NEW STANDAARD IS 751-07

DIM	MILLIMETERS		INCHES	
	MIN	MAX	MIN	MAX
A	4.80	5.00	0.189	0.197
B	3.80	4.00	0.150	0.157
C	1.35	1.75	0.053	0.069
D	0.33	0.51	0.013	0.020
G	1.27 BSC		0.050 BSC	
H	0.10	0.25	0.004	0.010
J	0.19	0.25	0.007	0.010
K	0.40	1.27	0.016	0.050
M	0°	8°	0°	8°
N	0.25	0.50	0.010	0.020
S	5.80	6.20	0.228	0.244

SOLDERING FOOTPRINT*

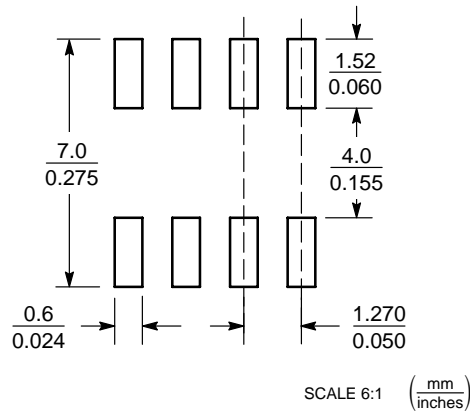

Figure 23. SO-8

*For additional information on our Pb-Free strategy and soldering details, please download the ON Semiconductor Soldering and Mounting Techniques Reference Manual, SOLDERRM/D.

ON Semiconductor and are registered trademarks of Semiconductor Components Industries, LLC (SCILLC). SCILLC reserves the right to make changes without further notice to any products herein. SCILLC makes no warranty, representation or guarantee regarding the suitability of its products for any particular purpose, nor does SCILLC assume any liability arising out of the application or use of any product or circuit, and specifically disclaims any and all liability, including without limitation special, consequential or incidental damages. "Typical" parameters which may be provided in SCILLC data sheets and/or specifications can and do vary in different applications and actual performance may vary over time. All operating parameters, including "Typicals" must be validated for each customer application by customer's technical experts. SCILLC does not convey any license under its patent rights nor the rights of others. SCILLC products are not designed, intended, or authorized for use as components in systems intended for surgical implant into the body, or other applications intended to support or sustain life, or for any other application in which the failure of the SCILLC product could create a situation where personal injury or death may occur. Should Buyer purchase or use SCILLC products for any such unintended or unauthorized application, Buyer shall indemnify and hold SCILLC and its officers, employees, subsidiaries, affiliates, and distributors harmless against all claims, costs, damages, and expenses, and reasonable attorney fees arising out of, directly or indirectly, any claim of personal injury or death associated with such unintended or unauthorized use, even if such claim alleges that SCILLC was negligent regarding the design or manufacture of the part. SCILLC is an Equal Opportunity/Affirmative Action Employer. This literature is subject to all applicable copyright laws and is not for resale in any manner.

PUBLICATION ORDERING INFORMATION

LITERATURE FULFILLMENT:
Literature Distribution Center for ON Semiconductor
P.O. Box 5163, Denver, Colorado 80217 USA
Phone: 303-675-2175 or 800-344-3860 Toll Free USA/Canada
Fax: 303-675-2176 or 800-344-3867 Toll Free USA/Canada
Email: orderlit@onsemi.com

N. American Technical Support: 800-282-9855 Toll Free
USA/Canada

Japan: ON Semiconductor, Japan Customer Focus Center
2-9-1 Kamimeguro, Meguro-ku, Tokyo, Japan 153-0051
Phone: 81-3-5773-3850

ON Semiconductor Website: <http://onsemi.com>

Order Literature: <http://www.onsemi.com/litorder>

For additional information, please contact your local Sales Representative.