

# MC12095

## 2.5 GHz Low Power Prescaler With Stand-By Mode

### Description

The MC12095 is a single modulus prescaler for low power frequency division of a 2.5 GHz high frequency input signal. MOSAIC V™ technology is utilized to achieve low power dissipation of 24 mW at a minimum supply voltage of 2.7 V.

On-chip output termination provides output current to drive a 2.0 pF (typical) high impedance load. If additional drive is required for the prescaler output, an external resistor can be added in parallel from the OUT pin to GND to increase the output power. Care must be taken not to exceed the maximum allowable current through the output.

Divide ratio control input (SW) selects the required divide ratio of +2 or +4. Stand-By mode is available to reduce current drain to 100 µA typical when the standby pin SB is switched LOW disabling the prescaler.

### Features

- 2.5 GHz Toggle Frequency
- Supply Voltage 2.7 V to 5.5 Vdc
- Low Power 8.7 mA Typical
- Operating Temperature -40°C to 85°C
- Divide by 2 or 4 Selected by the SW Pin
- Pb-Free Packages are Available

Table 1. FUNCTIONAL TABLE

SW	Divide Ratio
H	2
L	4

1. SW: H = ( $V_{CC} - 0.4$  V) to  $V_{CC}$ ; L = OPEN
2. SB: H = 2.0 V to  $V_{CC}$ ; L = GND to 0.8 V

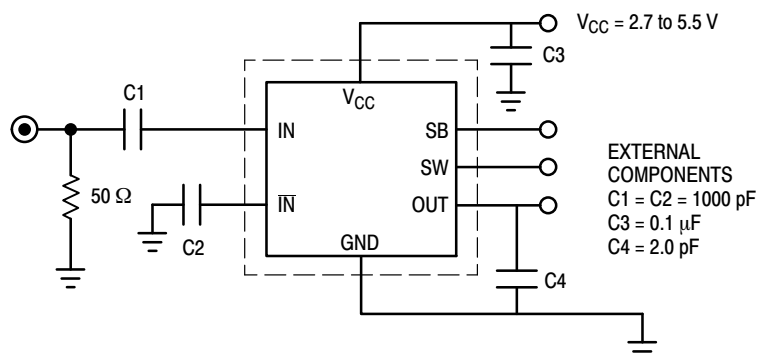

Figure 1. AC Test Circuit



ON Semiconductor™

<http://onsemi.com>

### MARKING DIAGRAMS

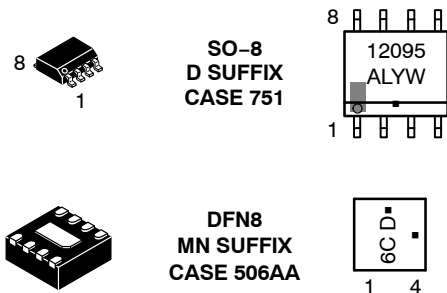

- A = Assembly Location
  - L = Wafer Lot
  - Y = Year
  - W = Work Week
  - = Pb-Free Package
- (Note: Microdot may be in either location)

### PIN CONNECTIONS

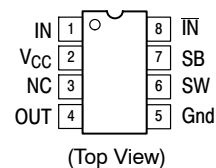

### ORDERING INFORMATION

See detailed ordering and shipping information in the package dimensions section on page 6 of this data sheet.

# MC12095

**Table 2. ATTRIBUTES**

Characteristics	Value	
Internal Input Pulldown Resistor	N/A	
Internal Input Pullup Resistor	N/A	
ESD Protection	Human Body Model Machine Model Charged Device Model	> 4 kV > 200 V > 2 kV
Moisture Sensitivity, Indefinite Time Out of Drypack (Note 1)	Pb Pkg	Pb-Free Pkg
	SOIC-8 DFN8	Level 1 Level 1
Flammability Rating	Oxygen Index: 28 to 34	UL 94 V-0 @ 0.125 in
Transistor Count	125 Devices	
Meets or exceeds JEDEC Spec EIA/JESD78 IC Latchup Test		

1. For additional information, see Application Note AND8003/D.

**Table 3. MAXIMUM RATINGS**

Symbol	Rating	Value	Unit
$V_{CC}$	Power Supply Voltage, Pin 2	-0.5 to 6.0	Vdc
$T_A$	Operating Temperature Range	-40 to 85	°C
$T_{stg}$	Storage Temperature Range	-65 to 150	°C
$I_O$	Maximum Output Current, Pin 4	8.0	mA
$\theta_{JC}$	Thermal Resistance (Junction-to-Case) (Note 2) DFN8	35 to 40	°C/W

Maximum ratings are those values beyond which device damage can occur. Maximum ratings applied to the device are individual stress limit values (not normal operating conditions) and are not valid simultaneously. If these limits are exceeded, device functional operation is not implied, damage may occur and reliability may be affected.

NOTE: ESD data available upon request.

2. JEDEC standard multilayer board - 2S2P (2 signal, 2 power). For DFN8 only, thermal exposed pad must be connected to a sufficient thermal conduit. Electrically connect to the most negative supply (GND) or leave unconnected, floating open.

**Table 4. ELECTRICAL CHARACTERISTICS** ( $V_{CC} = 2.7$  to  $5.5$  V;  $T_A = -40$  to  $85^\circ\text{C}$ , unless otherwise noted.)

Symbol	Characteristic	Min	Typ	Max	Unit	
$f_t$	Toggle Frequency (Sine Wave)	500	3.0	2.5	GHz	
$I_{CC}$	Supply Current	-	8.7	14	mA	
$I_{SB}$	Stand-By Current	-	100	200	$\mu\text{A}$	
$V_{IH1}$	Stand-By Input HIGH (SB)	2.0	-	$V_{CC} + 0.5$ V	V	
$V_{IL1}$	Stand-By Input LOW (SB)	GND	-	0.8	V	
$V_{IH2}$	Divide Ratio Control Input HIGH (SW)	$V_{CC} - 0.4$	$V_{CC}$	$V_{CC} + 0.5$ V	V	
$V_{IL2}$	Divide Ratio Control Input LOW (SW)	OPEN	OPEN	OPEN		
$V_{OUT}$	Output Voltage Swing (2pF Load)	500-1000 MHz Input 1000-1500 MHz Input 1500-2500 MHz Input	800 400 200	- 450 250	- - -	mVpp
$V_{IN}$	Input Voltage Sensitivity	200	-	1000	mVpp	

# MC12095

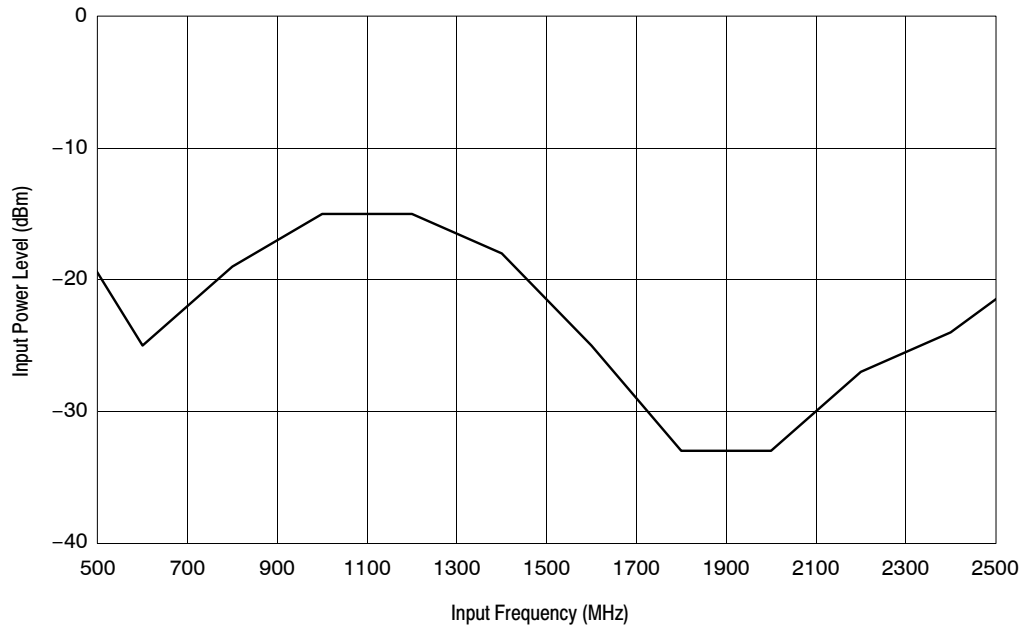

(Divide By 2 Mode, T = 25°C, V<sub>CC</sub> = 2.7 V)

**Figure 2. Typical Minimum Input Sensitivity versus Input Frequency**

# MC12095

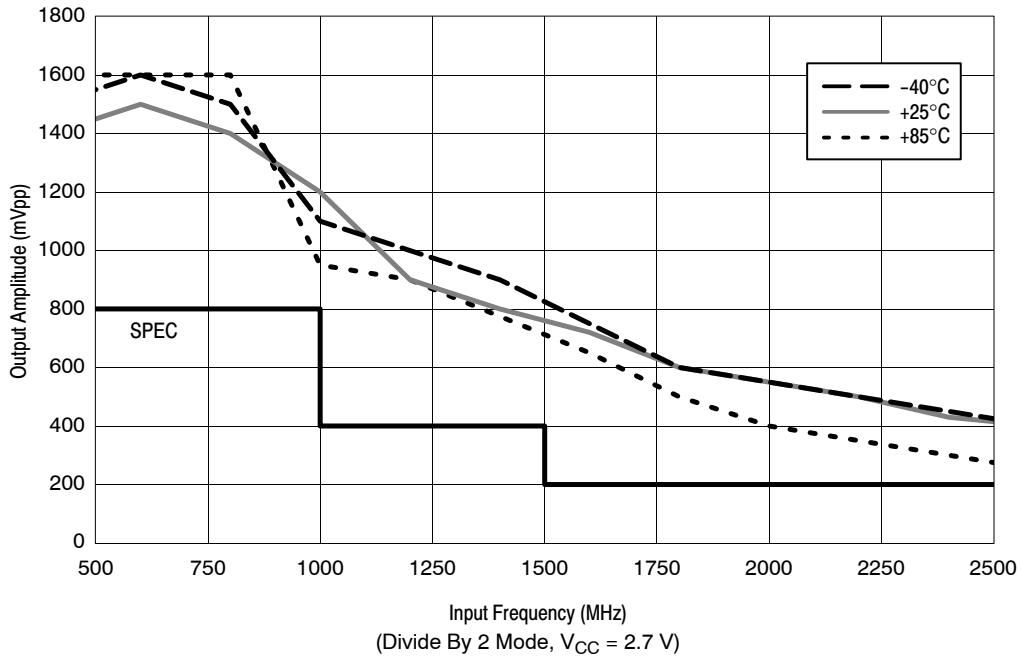

Figure 3. Typical Output Amplitude versus Frequency Over Temperature

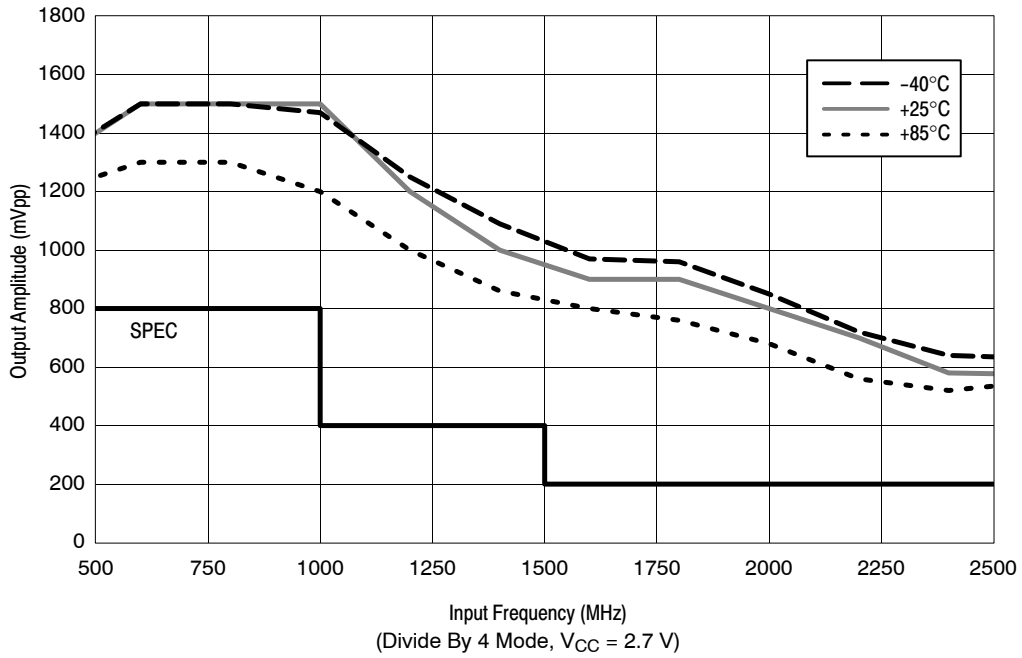
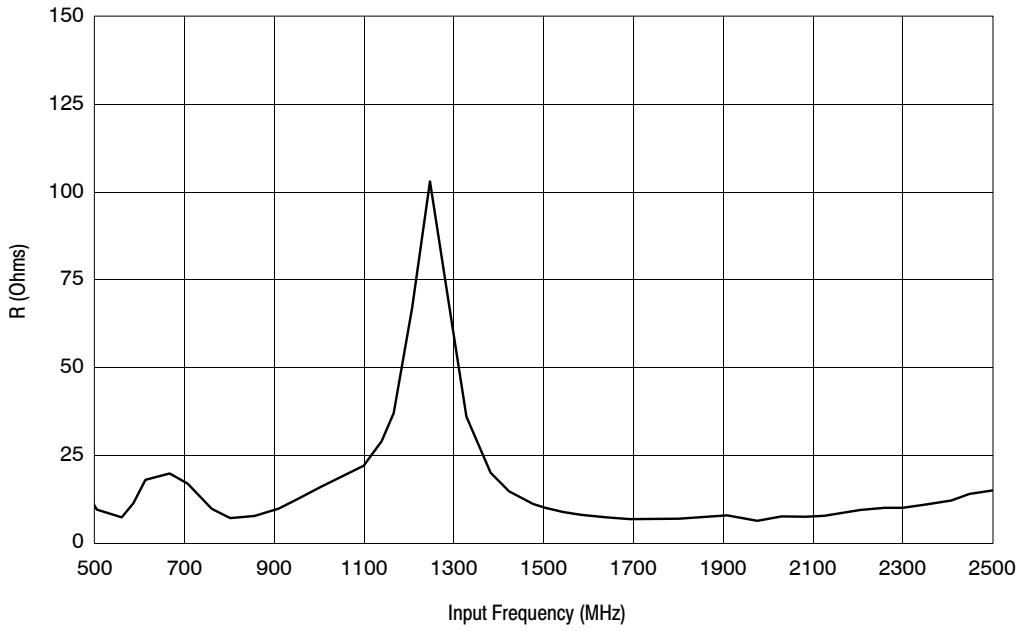
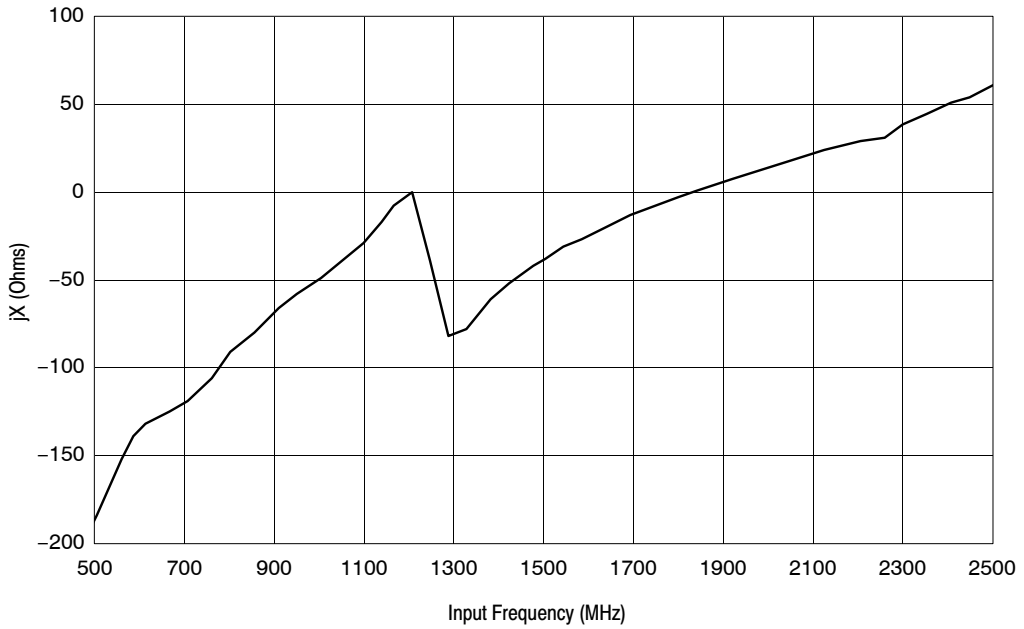

Figure 4. Typical Output Amplitude versus Frequency Over Temperature

# MC12095



**Figure 5. Input Impedance versus Frequency**



**Figure 6. Input Impedance versus Frequency**

# MC12095

## ORDERING INFORMATION

Device	Package	Shipping†
MC12095D	SOIC-8	98 Units / Rail
MC12095DG	SOIC-8 (Pb-Free)	98 Units / Rail
MC12095DR2	SOIC-8	98 Units / Rail
MC12095DR2G	SOIC-8 (Pb-Free)	98 Units / Rail
MC12095MNR4	DFN8	1000 / Tape & Reel
MC12095MNR4G	DFN8 (Pb-Free)	1000 / Tape & Reel

†For information on tape and reel specifications, including part orientation and tape sizes, please refer to our Tape and Reel Packaging Specifications Brochure, BRD8011/D.

# MC12095

## PACKAGE DIMENSIONS

SOIC-8 NB  
CASE 751-07  
ISSUE AG

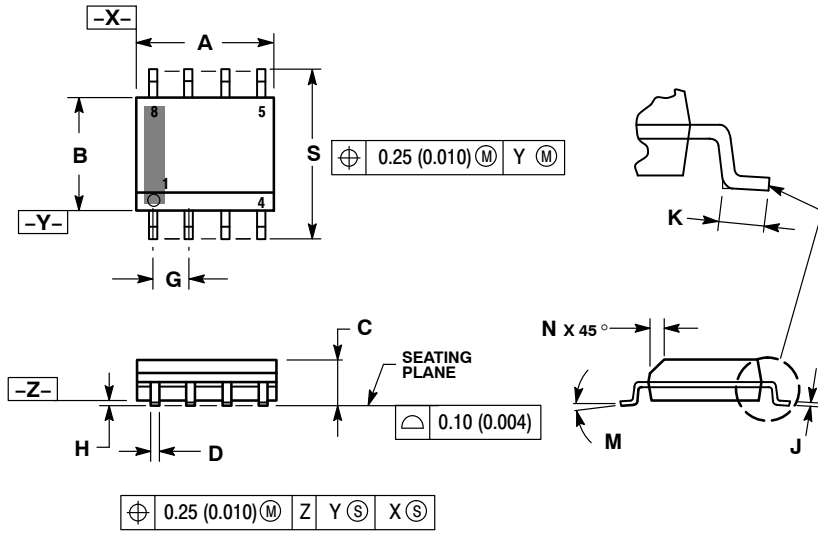

**NOTES:**

1. DIMENSIONING AND TOLERANCING PER ANSI Y14.5M, 1982.
2. CONTROLLING DIMENSION: MILLIMETER.
3. DIMENSION A AND B DO NOT INCLUDE MOLD PROTRUSION.
4. MAXIMUM MOLD PROTRUSION 0.15 (0.006) PER SIDE.
5. DIMENSION D DOES NOT INCLUDE DAMBAR PROTRUSION. ALLOWABLE DAMBAR PROTRUSION SHALL BE 0.127 (0.005) TOTAL IN EXCESS OF THE D DIMENSION AT MAXIMUM MATERIAL CONDITION.
6. 751-01 THRU 751-06 ARE OBSOLETE. NEW STANDARD IS 751-07.

DIM	MILLIMETERS		INCHES	
	MIN	MAX	MIN	MAX
A	4.80	5.00	0.189	0.197
B	3.80	4.00	0.150	0.157
C	1.35	1.75	0.053	0.069
D	0.33	0.51	0.013	0.020
G	1.27 BSC		0.050 BSC	
H	0.10	0.25	0.004	0.010
J	0.19	0.25	0.007	0.010
K	0.40	1.27	0.016	0.050
M	0°	8°	0°	8°
N	0.25	0.50	0.010	0.020
S	5.80	6.20	0.228	0.244

### SOLDERING FOOTPRINT\*

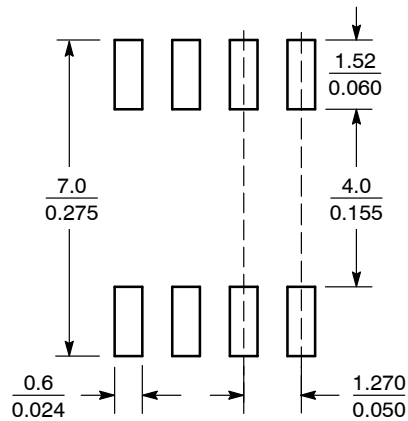

SCALE 6:1 ( $\frac{\text{mm}}{\text{inches}}$ )

\*For additional information on our Pb-Free strategy and soldering details, please download the ON Semiconductor Soldering and Mounting Techniques Reference Manual, SOLDERRM/D.

# MC12095

## PACKAGE DIMENSIONS

DFN8  
CASE 506AA-01  
ISSUE C

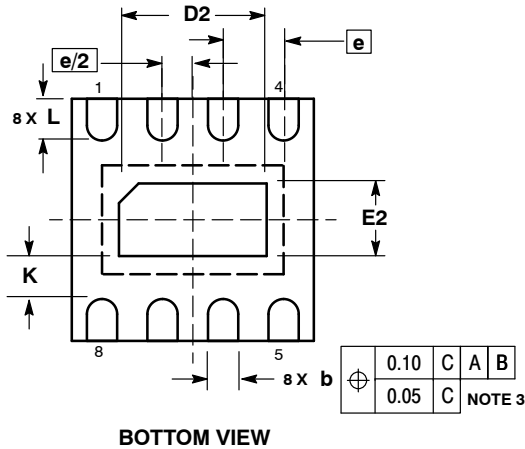
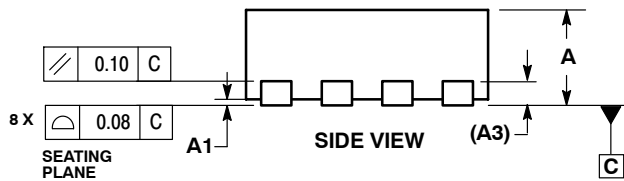
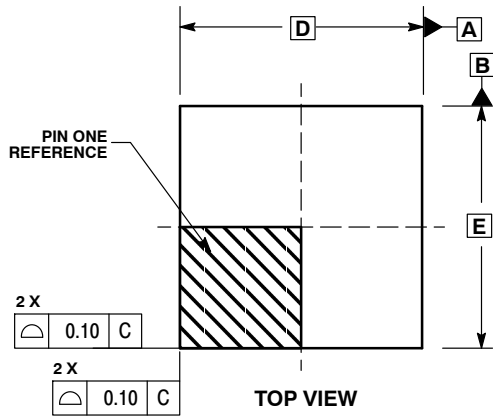

### NOTES:

1. DIMENSIONING AND TOLERANCING PER ASME Y14.5M, 1994 .
2. CONTROLLING DIMENSION: MILLIMETERS.
3. DIMENSION b APPLIES TO PLATED TERMINAL AND IS MEASURED BETWEEN 0.25 AND 0.30 MM FROM TERMINAL.
4. COPLANARITY APPLIES TO THE EXPOSED PAD AS WELL AS THE TERMINALS.

MILLIMETERS		
DIM	MIN	MAX
A	0.80	1.00
A1	0.00	0.05
A3	0.20	REF
b	0.20	0.30
D	2.00	BSC
D2	1.10	1.30
E	2.00	BSC
E2	0.70	0.90
e	0.50	BSC
K	0.20	---
L	0.25	0.35

MOSAIC V is a trademark of Motorola, Inc.

**ON Semiconductor** and **ON** are registered trademarks of Semiconductor Components Industries, LLC (SCILLC). SCILLC reserves the right to make changes without further notice to any products herein. SCILLC makes no warranty, representation or guarantee regarding the suitability of its products for any particular purpose, nor does SCILLC assume any liability arising out of the application or use of any product or circuit, and specifically disclaims any and all liability, including without limitation special, consequential or incidental damages. "Typical" parameters which may be provided in SCILLC data sheets and/or specifications can and do vary in different applications and actual performance may vary over time. All operating parameters, including "Typicals" must be validated for each customer application by customer's technical experts. SCILLC does not convey any license under its patent rights nor the rights of others. SCILLC products are not designed, intended, or authorized for use as components in systems intended for surgical implant into the body, or other applications intended to support or sustain life, or for any other application in which the failure of the SCILLC product could create a situation where personal injury or death may occur. Should Buyer purchase or use SCILLC products for any such unintended or unauthorized application, Buyer shall indemnify and hold SCILLC and its officers, employees, subsidiaries, affiliates, and distributors harmless against all claims, costs, damages, and expenses, and reasonable attorney fees arising out of, directly or indirectly, any claim of personal injury or death associated with such unintended or unauthorized use, even if such claim alleges that SCILLC was negligent regarding the design or manufacture of the part. SCILLC is an Equal Opportunity/Affirmative Action Employer. This literature is subject to all applicable copyright laws and is not for resale in any manner.

### PUBLICATION ORDERING INFORMATION

**LITERATURE FULFILLMENT:**  
Literature Distribution Center for ON Semiconductor  
P.O. Box 5163, Denver, Colorado 80217 USA  
**Phone:** 303-675-2175 or 800-344-3860 Toll Free USA/Canada  
**Fax:** 303-675-2176 or 800-344-3867 Toll Free USA/Canada  
**Email:** orderlit@onsemi.com

**N. American Technical Support:** 800-282-9855 Toll Free  
USA/Canada  
**Europe, Middle East and Africa Technical Support:**  
Phone: 421 33 790 2910  
**Japan Customer Focus Center**  
Phone: 81-3-5773-3850

**ON Semiconductor Website:** [www.onsemi.com](http://www.onsemi.com)  
**Order Literature:** <http://www.onsemi.com/orderlit>  
For additional information, please contact your local Sales Representative