

## Ultra Low Power DAC for Portable Audio Applications

---

### DESCRIPTION

The WM8910 is a high performance ultra-low power stereo DAC optimised for portable audio applications.

The device features stereo ground-referenced headphone amplifiers using the Wolfson 'Class W' amplifier techniques - incorporating an innovative dual-mode charge pump architecture - to optimise efficiency and power consumption during playback. The ground-referenced outputs eliminate headphone coupling capacitors. Both headphone and line outputs include common mode feedback paths to reject ground noise.

Control sequences for audio path setup can be pre-loaded and executed by an integrated sequencer to reduce software driver development and eliminate pops and clicks via Wolfson's SilentSwitch™ technology.

The analogue input stage can be configured for single ended or differential inputs. Up to 2 stereo microphone or line inputs may be connected. The input impedance is constant with PGA gain setting.

A stereo digital microphone interface is provided, which can also be mixed with the mic/line signals at the output mixers.

A dynamic range controller provides compression and level control to support a wide range of portable recording applications. Anti-clip and quick release features offer good performance in the presence of loud impulsive noises.

Common audio sampling frequencies are supported from a range of external clocks, either directly or generated via the FLL.

The WM8910 can operate directly from a single 1.8V switched supply. For optimal power consumption, the digital core can be operated from a 1.0V supply.

### FEATURES

- 4.5mW power consumption for DAC to headphone playback
- DAC SNR 96dB typical, THD -86dB typical
- Control sequencer for pop minimised start-up and shut-down
- Single register write for default start-up sequence
- Integrated FLL provides all necessary clocks
  - Self-clocking modes allow processor to sleep
  - All standard sample rates from 8kHz to 96kHz
- Stereo digital microphone input
- 2 single ended inputs per stereo channel
- 1 fully differential mic / line input per stereo channel
- Digital Dynamic Range Controller (compressor / limiter)
- Digital sidetone mixing
- Ground-referenced headphone driver
- Ground-referenced line outputs
- Stereo differential line driver for direct interface to WM9001 speaker driver
- 40-pin QFN package (5x5mm)

### APPLICATIONS

- Portable multimedia players
- Multimedia handsets
- Handheld gaming

BLOCK DIAGRAM

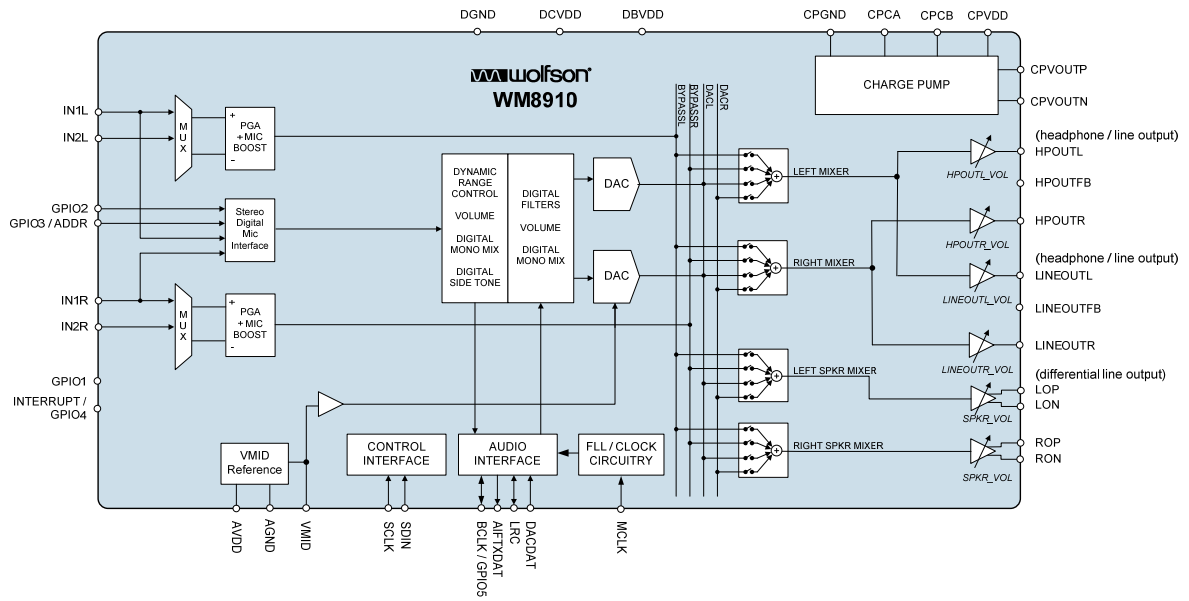

## TABLE OF CONTENTS

<b>DESCRIPTION</b> .....	<b>1</b>
<b>FEATURES</b> .....	<b>1</b>
<b>APPLICATIONS</b> .....	<b>1</b>
<b>BLOCK DIAGRAM</b> .....	<b>2</b>
<b>TABLE OF CONTENTS</b> .....	<b>3</b>
<b>PIN CONFIGURATION</b> .....	<b>6</b>
<b>ORDERING INFORMATION</b> .....	<b>6</b>
<b>PIN DESCRIPTION</b> .....	<b>7</b>
<b>ABSOLUTE MAXIMUM RATINGS</b> .....	<b>8</b>
<b>RECOMMENDED OPERATING CONDITIONS</b> .....	<b>8</b>
<b>ELECTRICAL CHARACTERISTICS</b> .....	<b>9</b>
TERMINOLOGY .....	9
COMMON TEST CONDITIONS .....	9
INPUT SIGNAL PATH .....	10
OUTPUT SIGNAL PATH .....	10
BYPASS PATH .....	12
CHARGE PUMP .....	13
FLL .....	13
OTHER PARAMETERS .....	13
<b>POWER CONSUMPTION</b> .....	<b>14</b>
COMMON TEST CONDITIONS .....	14
POWER CONSUMPTION MEASUREMENTS .....	14
<b>SIGNAL TIMING REQUIREMENTS</b> .....	<b>16</b>
COMMON TEST CONDITIONS .....	16
MASTER CLOCK .....	16
AUDIO INTERFACE TIMING .....	17
MASTER MODE .....	17
SLAVE MODE.....	18
TDM MODE .....	19
CONTROL INTERFACE TIMING .....	20
<b>DIGITAL FILTER CHARACTERISTICS</b> .....	<b>21</b>
DAC FILTER RESPONSES .....	22
DE-EMPHASIS FILTER RESPONSES .....	24
<b>DEVICE DESCRIPTION</b> .....	<b>25</b>
INTRODUCTION .....	25
ANALOGUE INPUT SIGNAL PATH .....	26
INPUT PGA ENABLE .....	27
INPUT PGA CONFIGURATION .....	27
SINGLE-ENDED INPUT .....	29
DIFFERENTIAL LINE INPUT.....	29
DIFFERENTIAL MICROPHONE INPUT .....	30
INPUT PGA GAIN CONTROL .....	30
INPUT PGA COMMON MODE AMPLIFIER .....	32
DIGITAL MICROPHONE INTERFACE .....	32
DIGITAL MICROPHONE VOLUME CONTROL .....	34
DYNAMIC RANGE CONTROL (DRC) .....	37
COMPRESSION/LIMITING CAPABILITIES .....	37
GAIN LIMITS.....	38

DYNAMIC CHARACTERISTICS .....	39
ANTI-CLIP CONTROL .....	40
QUICK RELEASE CONTROL .....	40
GAIN SMOOTHING .....	41
INITIALISATION .....	42
<b>DIGITAL MIXING .....</b>	<b>43</b>
DIGITAL MIXING PATHS .....	43
DAC INTERFACE VOLUME BOOST .....	44
DIGITAL SIDETONE .....	45
<b>DIGITAL-TO-ANALOGUE CONVERTER (DAC) .....</b>	<b>46</b>
DAC DIGITAL VOLUME CONTROL .....	46
DAC SOFT MUTE AND SOFT UN-MUTE .....	49
DAC MONO MIX .....	50
DAC DE-EMPHASIS .....	50
DAC SLOPING STOPBAND FILTER .....	51
DAC BIAS CONTROL .....	51
DAC OVERSAMPLING RATIO (OSR) .....	52
<b>OUTPUT SIGNAL PATH .....</b>	<b>53</b>
OUTPUT SIGNAL PATHS ENABLE .....	54
HEADPHONE / LINE OUTPUT SIGNAL PATHS ENABLE .....	55
OUTPUT PGA BIAS CONTROL .....	58
OUTPUT DRIVERS BIAS CONTROL .....	58
OUTPUT MIXER CONTROL .....	59
OUTPUT VOLUME CONTROL .....	61
<b>ANALOGUE OUTPUTS .....</b>	<b>65</b>
HEADPHONE OUTPUTS – HPOUTL AND HPOUTR .....	65
LINE OUTPUTS – LINEOUTL AND LINEOUTR .....	65
DIFFERENTIAL LINE OUTPUTS – LON/LOP AND RON/ROP .....	65
EXTERNAL COMPONENTS FOR GROUND-REFERENCED OUTPUTS .....	66
<b>REFERENCE VOLTAGES AND MASTER BIAS .....</b>	<b>67</b>
<b>POP SUPPRESSION CONTROL .....</b>	<b>69</b>
DISABLED INPUT / OUTPUT CONTROL .....	69
DIFFERENTIAL LINE OUTPUT DISCHARGE CONTROL .....	69
<b>CHARGE PUMP .....</b>	<b>70</b>
<b>DC SERVO .....</b>	<b>71</b>
<b>DIGITAL AUDIO INTERFACE .....</b>	<b>74</b>
MASTER AND SLAVE MODE OPERATION .....	74
OPERATION WITH TDM .....	75
BCLK FREQUENCY .....	76
AUDIO DATA FORMATS (NORMAL MODE) .....	76
AUDIO DATA FORMATS (TDM MODE) .....	78
<b>DIGITAL AUDIO INTERFACE CONTROL .....</b>	<b>80</b>
BCLK AND LRCLK CONTROL .....	81
COMPANDING .....	83
LOOPBACK .....	85
<b>CLOCKING AND SAMPLE RATES .....</b>	<b>85</b>
CLK_SYS CONTROL .....	87
CONTROL INTERFACE CLOCKING .....	88
AUTOMATIC CLOCKING CONFIGURATION .....	88
USB CLOCKING MODE .....	90
DAC OPERATION AT 88.2K / 96K .....	90
DIGITAL MICROPHONE (DMIC) OPERATION .....	90
<b>FREQUENCY LOCKED LOOP (FLL) .....</b>	<b>91</b>
FREE-RUNNING FLL CLOCK .....	94

---

GPIO OUTPUTS FROM FLL .....	95
EXAMPLE FLL CALCULATION.....	95
EXAMPLE FLL SETTINGS.....	96
GENERAL PURPOSE INPUT/OUTPUT (GPIO).....	97
INTERRUPTS .....	102
CONTROL INTERFACE.....	104
CONTROL WRITE SEQUENCER.....	107
INITIATING A SEQUENCE.....	107
PROGRAMMING A SEQUENCE .....	108
DEFAULT SEQUENCES .....	111
START-UP SEQUENCE.....	111
SHUTDOWN SEQUENCE.....	114
POWER-ON RESET .....	116
QUICK START-UP AND SHUTDOWN .....	118
QUICK START-UP (DEFAULT SEQUENCE).....	118
QUICK SHUTDOWN (DEFAULT SEQUENCE) .....	118
SOFTWARE RESET AND CHIP ID .....	119
<b>REGISTER MAP.....</b>	<b>120</b>
REGISTER BITS BY ADDRESS.....	123
<b>APPLICATIONS INFORMATION .....</b>	<b>161</b>
RECOMMENDED EXTERNAL COMPONENTS.....	161
<b>PACKAGE DIMENSIONS.....</b>	<b>162</b>
<b>IMPORTANT NOTICE .....</b>	<b>163</b>
ADDRESS.....	163
<b>REVISION HISTORY .....</b>	<b>164</b>

**PIN CONFIGURATION**

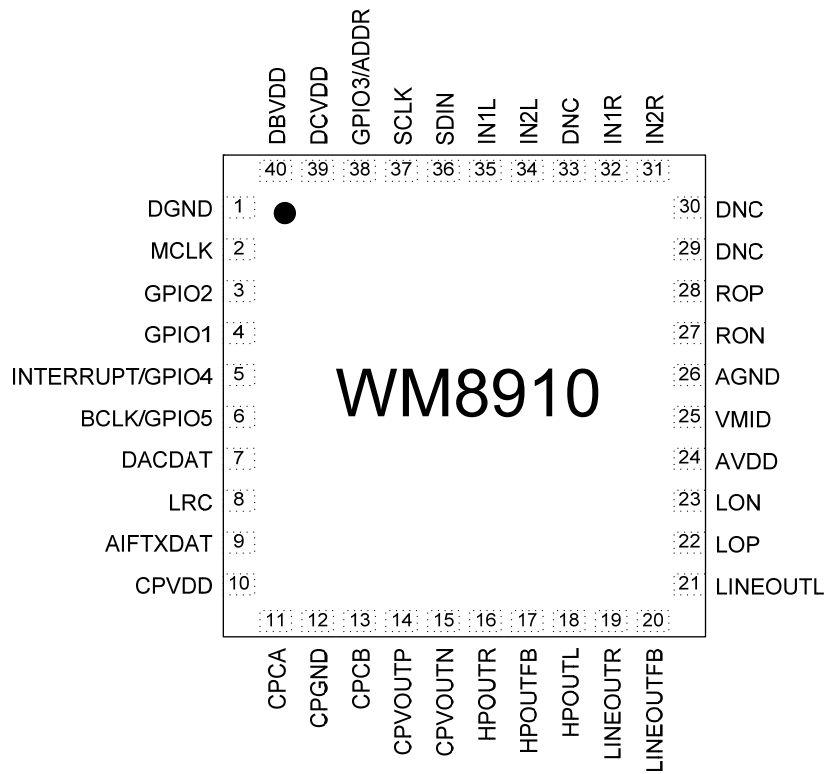

**ORDERING INFORMATION**

DEVICE	TEMPERATURE RANGE	PACKAGE	MOISTURE SENSITIVITY LEVEL	PEAK SOLDERING TEMPERATURE
WM8910LGEFK/V	-40°C to +85°C	40-lead QFN (5x5x0.55mm, lead-free)	MSL3	260°C
WM8910LGEFK/RV	-40°C to +85°C	40-lead QFN (5x5x0.55mm, lead-free, tape and reel)	MSL3	260°C

**Note:**

Tube quantity = 95  
 Reel quantity = 3,500

**PIN DESCRIPTION**

NAME	PIN	TYPE	DESCRIPTION
DGND	1	Supply	Digital ground (return path for DCVDD and DBVDD)
MCLK	2	Digital Input	Master clock for DAC
GPIO2	3	Digital Input/Output	GPIO2 / Digital microphone input
GPIO1	4	Digital Input/Output	GPIO1 / Digital microphone input
INTERRUPT / GPIO4	5	Digital Output	Interrupt output / GPIO4
BCLK / GPIO5	6	Digital Input/Output	Audio interface bit clock / GPIO5
DACDAT	7	Digital Input	DAC digital audio data
LRC	8	Digital Input/Output	Audio interface left / right clock
AIFTXDAT	9	Digital Output	Digital Microphone audio data
CPVDD	10	Supply	Charge pump power supply
CPCA	11	Analogue Output	Charge pump flyback capacitor pin
CPGND	12	Supply	Charge pump ground
CPCB	13	Analogue Output	Charge pump flyback capacitor pin
CPVOUTP	14	Analogue Output	Charge pump positive decoupling (powers HPOUTL/R, LINEOUTL/R)
CPVOUTN	15	Analogue Output	Charge pump negative decoupling (powers HPOUTL/R, LINEOUTL/R)
HPOUTR	16	Analogue Output	Right headphone output (line or headphone)
HPOUTFB	17	Analogue Input	Headphone ground
HPOUTL	18	Analogue Output	Left headphone output (line or headphone)
LINEOUTR	19	Analogue Output	Right line output 1 (line output)
LINEOUTFB	20	Analogue Input	Line-out ground
LINEOUTL	21	Analogue Output	Left line output 1 (line output)
LOP	22	Analogue Output	Left differential output positive side
LON	23	Analogue Output	Left differential output negative side
AVDD	24	Supply	Analogue power supply (powers analogue, LOP, LON, ROP, RON)
VMID	25	Analogue Output	Midrail voltage decoupling capacitor
AGND	26	Supply	Analogue power return
RON	27	Analogue Output	Right differential output negative side
ROP	28	Analogue Output	Right differential output positive side
DNC	29	n/a	Unused - Do Not Connect
DNC	30	n/a	Unused - Do Not Connect
IN2R	31	Analogue Input	Right channel input 2
IN1R	32	Analogue Input	Right channel input 1 / Digital microphone input
DNC	33	n/a	Unused - Do Not Connect
IN2L	34	Analogue Input	Left channel input 2
IN1L	35	Analogue Input	Left channel input 1 / Digital microphone input
SDIN	36	Digital Input/Output	Control interface data input / 2-wire acknowledge output
SCLK	37	Digital Input	Control interface clock Input
GPIO3 / ADDR	38	Digital Input/Output	GPIO3 / control interface address selection
DCVDD	39	Supply	Digital core supply
DBVDD	40	Supply	Digital buffer supply (powers audio interface and control interface)

## ABSOLUTE MAXIMUM RATINGS

Absolute Maximum Ratings are stress ratings only. Permanent damage to the device may be caused by continuously operating at or beyond these limits. Device functional operating limits and guaranteed performance specifications are given under Electrical Characteristics at the test conditions specified.



ESD Sensitive Device. This device is manufactured on a CMOS process. It is therefore generically susceptible to damage from excessive static voltages. Proper ESD precautions must be taken during handling and storage of this device.

Wolfson tests its package types according to IPC/JEDEC J-STD-020B for Moisture Sensitivity to determine acceptable storage conditions prior to surface mount assembly. These levels are:

MSL1 = unlimited floor life at <30°C / 85% Relative Humidity. Not normally stored in moisture barrier bag.

MSL2 = out of bag storage for 1 year at <30°C / 60% Relative Humidity. Supplied in moisture barrier bag.

MSL3 = out of bag storage for 168 hours at <30°C / 60% Relative Humidity. Supplied in moisture barrier bag.

The Moisture Sensitivity Level for each package type is specified in Ordering Information.

CONDITION	MIN	MAX
AVDD, DCVDD	-0.3V	+2.5V
DBVDD,	-0.3V	+4.5V
CPVDD	-0.3V	+2.2V
HPOUTL, HPOUTR, LINEOUTL, LINEOUTR	(CPVDD + 0.3V) * -1	CPVDD + 0.3
Voltage range digital inputs	DGND -0.3V	DBVDD +0.3V
Voltage range analogue inputs	AGND -0.3V	AVDD +0.3V
Temperature range, T <sub>A</sub>	-40°C	+85°C
Storage temperature after soldering	-65°C	+150°C

### Notes:

1. Analogue and digital grounds must always be within 0.3V of each other.
2. All digital and analogue supplies are completely independent from each other; there is no restriction on power supply sequencing.
3. HPOUTL, HPOUTR, LINEOUTL, LINEOUTR are outputs, and should not normally become connected to DC levels. However, if the limits above are exceeded, then damage to the WM8910 may occur.

## RECOMMENDED OPERATING CONDITIONS

PARAMETER	SYMBOL	MIN	TYP	MAX	UNIT
Digital supply range (Core)	DCVDD	0.95	1.0	1.89	V
Digital supply range (Buffer)	DBVDD	1.42	1.8	3.6	V
Analogue supplies range	AVDD	1.71	1.8	2.0	V
Charge pump supply range	CPVDD	1.71	1.8	2.0	V
Ground	DGND, AGND, CPGND		0		V
Operating Temperature (ambient)	T <sub>A</sub>	-40	+25	+85	°C

## ELECTRICAL CHARACTERISTICS

### TERMINOLOGY

1. Signal-to-Noise Ratio (dB) – SNR is the difference in level between a full scale output signal and the device output noise with no signal applied, measured over a bandwidth of 20Hz to 20kHz. This ratio is also called idle channel noise. (No Auto-zero or Automute function is employed).
2. Total Harmonic Distortion (dB) – THD is the difference in level between a 1kHz full scale sinewave output signal and the first seven harmonics of the output signal. The amplitude of the fundamental frequency of the output signal is compared to the RMS value of the next seven harmonics and expressed as a ratio.
3. Total Harmonic Distortion + Noise (dB) – THD+N is the difference in level between a 1kHz full scale sine wave output signal and all noise and distortion products in the audio band. The amplitude of the fundamental reference frequency of the output signal is compared to the RMS value of all other noise and distortion products and expressed as a ratio.
4. Channel Separation (dB) – is a measure of the coupling between left and right channels. A full scale signal is applied to the left channel only, the right channel amplitude is measured. Then a full scale signal is applied to the right channel only and the left channel amplitude is measured. The worst case channel separation is quoted as a ratio.
5. Channel Level Matching (dB) – measures the difference in gain between the left and the right channels.
6. Power Supply Rejection Ratio (dB) – PSRR is a measure of ripple attenuation between the power supply pin and an output path. With the signal path idle, a small signal sine wave is summed onto the power supply rail, The amplitude of the sine wave is measured at the output port and expressed as a ratio.
7. All performance measurements carried out with 20kHz AES17 low pass filter for distortion measurements, and an A-weighted filter for noise measurement. Failure to use such a filter will result in higher THD and lower SNR and Dynamic Range readings than are found in the Electrical Characteristics. The low pass filter removes out of band noise; although it is not audible it may affect dynamic specification values.

### COMMON TEST CONDITIONS

Unless otherwise stated, the following test conditions apply throughout the following sections:

- DCVDD = 1.0V
- DBVDD = 1.8V
- AVDD = CPVDD = 1.8V
- Ambient temperature = +25°C
- Audio signal: 1kHz sine wave, sampled at 48kHz with 24-bit data resolution

Additional, specific test conditions are given within the relevant sections below.

## INPUT SIGNAL PATH

PGA and microphone boost					
PARAMETER	TEST CONDITIONS	MIN	TYP	MAX	UNIT
Minimum PGA gain setting	L_MODE/R_MODE= 00b or 01b		-1.55		dB
	L_MODE/R_MODE= 10b		+12		
Maximum PGA gain setting	L_MODE/R_MODE= 00b or 01b		+28.28		dB
	L_MODE/R_MODE= 10b		+30		
Single-ended to differential conversion gain	L_MODE/R_MODE= 00b		+6		dB
PGA gain accuracy	L_MODE/R_MODE= 00b Gain -1.55 to +6.7dB	-1		+1	dB
	L_MODE/R_MODE= 00b Gain +7.5 to +28.3dB	-1.5		+1.5	
	L_MODE/R_MODE= 1X Gain +12 to +24dB	-1		+1	
	L_MODE/R_MODE= 1X Gain +27 to +30dB	-1.5		+1.5	
Mute attenuation	all modes of operation		88		dB
Equivalent input noise	L_MODE/R_MODE= 00b or 01b		114		$\mu\text{Vrms}$ $\text{nV}/\sqrt{\text{Hz}}$
			828		

## OUTPUT SIGNAL PATH

Stereo Playback to Headphones - DAC input to HPOUTL+HPOUTR pins with 15 $\Omega$ load						
Test conditions: HPOUTL_VOL = HPOUTR_VOL = 111001b (0dB)						
PARAMETER	SYMBOL	TEST CONDITIONS	MIN	TYP	MAX	UNIT
Output Power (per Channel)	$P_o$	1% THD $R_{\text{Load}}= 30\Omega$		28 0.91 -0.76		mW Vrms dBV
		1% THD $R_{\text{Load}}= 15\Omega$		30 0.67 -3.47		mW Vrms dBV
DC Offset		DC servo enabled, calibration complete.	0		+/-1.5	mV
Signal to Noise Ratio	SNR	A-weighted	90	96		dB
Total Harmonic Distortion	THD	$R_L=30\Omega$ ; $P_o=2\text{mW}$		-93		dB
		$R_L=30\Omega$ ; $P_o=20\text{mW}$		-82		
		$R_L=15\Omega$ ; $P_o=2\text{mW}$		-83	-72	
		$R_L=15\Omega$ ; $P_o=20\text{mW}$		-83		
Total Harmonic Distortion + Noise	THD+N	$R_L=30\Omega$ ; $P_o=2\text{mW}$		-90		dB
		$R_L=30\Omega$ ; $P_o=20\text{mW}$		-82		
		$R_L=15\Omega$ ; $P_o=2\text{mW}$		-81	-70	
		$R_L=15\Omega$ ; $P_o=20\text{mW}$		-81		
Channel Separation		1kHz signal, 0dBFS		100		dB
		10kHz signal, 0dBFS		85		
Channel Level Matching		1kHz signal, 0dBFS		+/-1		dB
Power Supply Rejection Ratio	PSRR	1kHz, 100mV pk-pk		60		dB
		20kHz, 100mV pk-pk		40		

<b>Stereo Playback to Line-out - DAC input to LINEOUTL+LINEOUTR pins with 3.01k<math>\Omega</math> / 50pF load</b>						
Test conditions: LINEOUTL_VOL = LINEOUTR_VOL = 111001b (0dB)						
PARAMETER	SYMBOL	TEST CONDITIONS	MIN	TYP	MAX	UNIT
Full Scale Output Signal Level		DAC 0dBFS output at 0dB volume	0.95	1.0	1.05	Vrms
			-0.446	0	0.424	dBV
			2.69	2.83	2.97	Vpk-pk
DC offset		DC servo enabled. Calibration complete.	0		+/-1.5	mV
Signal to Noise Ratio	SNR	A-weighted	90	95		dB
Total Harmonic Distortion	THD	3.01k $\Omega$ load		-86	-77	dB
Total Harmonic Distortion + Noise	THD+N	3.01k $\Omega$ load		-84	-75	dB
Channel Separation		1kHz signal, 0dBFS		100		dB
		10kHz signal, 0dBFS		85		
Channel Level Matching		1kHz signal, 0dBFS		+/-1dB		dB
Power Supply Rejection Ratio	PSRR	1kHz, 100mVpk-pk		60		dB
		20kHz, 100mV pk-pk		40		

<b>Stereo Playback to Differential Line-out - DAC input to LOP+LON or ROP+RON pins with 10k<math>\Omega</math> / 50pF load</b>						
Test conditions: SPKR_LVOL = SPKR_RVOL = 111001b (0dB)						
PARAMETER	SYMBOL	TEST CONDITIONS	MIN	TYP	MAX	UNIT
Full Scale Output Signal Level		0dBFS Measured Differentially	0.95	1.0	1.05	Vrms
			-0.446	0	0.424	dBV
			2.69	2.83	2.97	Vpk-pk
Common mode output level				AVDD/2		
Common mode output error				+/-7		mV
Signal to Noise Ratio	SNR	A-weighted	90	95		dB
Total Harmonic Distortion	THD			-92	-82	dB
Total Harmonic Distortion + Noise	THD+N			-88	-80	dB
Channel Separation		1kHz signal, 0dBFS		100		dB
		10kHz signal, 0dBFS		85		
Channel Level Matching		1kHz signal		+/-1dB		dB
Power Supply Rejection Ratio	PSRR	1kHz, 100mVpk-pk		60		dB
		20kHz, 100mV pk-pk		40		

<b>Output PGAs (HP, LINE and Differential LINE)</b>					
PARAMETER	TEST CONDITIONS	MIN	TYP	MAX	UNIT
Minimum PGA gain setting			-57		dB
Maximum PGA gain setting			6		dB
PGA Gain Step Size			1		dB
PGA gain accuracy	+6dB to 0dB	-1.5		+1.5	dB
PGA gain accuracy	0dB to -57dB	-1		+1	dB
Mute attenuation	HPOUTL/R		77		dB
	LINEOUTL/R		79		
	Differential LINE (LOP-LOR/ROP-RON)		105		dB

**BYPASS PATH**

<b>Differential stereo line input to stereo line output- IN1L-IN2L / IN1R-IN2R pins to LINEOUTL+LINEOUTR pins with 3.01k<math>\Omega</math> / 50pF load</b>						
Test conditions: L_MODE = R_MODE = 01b (Differential Line) LIN_VOL = RIN_VOL = 00101b (0dB) LINEOUTL_VOL = LINEOUTR_VOL = 111001b (0dB) Total signal path gain = 0dB						
PARAMETER	SYMBOL	TEST CONDITIONS	MIN	TYP	MAX	UNIT
Maximum Line Input Signal Level applied to IN2L or IN2R				1.0 0 2.83		Vrms dBV Vpk-pk
Full Scale Output Signal Level			0.95 -0.446 2.69	1.0 0 2.83	1.05 0.424 2.97	Vrms dBV Vpk-pk
Signal to Noise Ratio	SNR	A-weighted	85	97		dBV
Total Harmonic Distortion	THD	-1.0dBV input		-92	-82	dBV
Total Harmonic Distortion + Noise	THD+N	-1.0dBV input		-89	-80	dBV
Channel Separation		1kHz signal, -1dBV		85		dB
		10kHz signal, -1dBV		80		
Channel Level Matching		1kHz signal, -1dBV		+/-1		dB
Power Supply Rejection Ratio	PSRR	1kHz, 100mVpk-pk		56		dB
		20kHz, 100mV pk-pk		40		

**CHARGE PUMP**

PARAMETER	SYMBOL	TEST CONDITIONS	MIN	TYP	MAX	UNIT
Charge pump start-up time				40		μs
<b>External component requirements</b>						
To achieve specified headphone output power and performance						
Flyback capacitor (between CPCA and CPCB pins)	C <sub>FB</sub>	at 2V	1			μF
CPVOUTP capacitor		at 2V	2			μF
CPVOUTN capacitor		at 2V	2			μF

**FLL**

PARAMETER	SYMBOL	TEST CONDITIONS	MIN	TYP	MAX	UNIT
Input Frequency	F <sub>REF</sub>	FLL_CLK_REF_DIV = 00	0.032		13.5	MHz
		FLL_CLK_REF_DIV = 01	0.032		27	MHz
Lock time				2		ms
Free-running mode start-up time		VMID enabled		100		μs
Free-running mode frequency accuracy		Reference supplied initially		+/-10		%
		No reference provided		+/-30		%

**OTHER PARAMETERS**

VMID Reference						
PARAMETER	TEST CONDITIONS	MIN	TYP	MAX	UNIT	
Midrail Reference Voltage (VMID pin)		-3%	AVDD/2	+3%	V	

Digital Inputs / Outputs						
PARAMETER	SYMBOL	TEST CONDITIONS	MIN	TYP	MAX	UNIT
Input HIGH Level	V <sub>IH</sub>		0.7×DBVDD			V
Input LOW Level	V <sub>IL</sub>				0.3×DBVDD	V
Output HIGH Level	V <sub>OH</sub>	I <sub>OH</sub> = +1mA	0.9×DBVDD			V
Output LOW Level	V <sub>OL</sub>	I <sub>OL</sub> = -1mA			0.1×DBVDD	V

## POWER CONSUMPTION

The WM8910 power consumption is dependent on many parameters. Most significantly, it depends on supply voltages, sample rates, mode of operation, and output loading.

The power consumption on each supply rail varies approximately with the square of the voltage. Power consumption is greater at fast sample rates than at slower ones. When the digital audio interface is operating in Master mode, the DBVDD current is significantly greater than in Slave mode. (Note also that power savings can be made by using MCLK as the BCLK source in Slave mode.) The output load conditions (impedance, capacitance and inductance) can also impact significantly on the device power consumption.

## COMMON TEST CONDITIONS

Unless otherwise stated, the following test conditions apply throughout the following sections:

- Ambient temperature = +25°C
- Audio signal = quiescent (zero amplitude)
- Sample rate = 44.1kHz
- MCLK = 12MHz
- Audio interface mode = Master (LRCLK\_DIR=1, BCLK\_DIR=1)
- CLK\_SRC\_SEL = 0 (System clock comes direct from MCLK, not from FLL)

Additional, variant test conditions are quoted within the relevant sections below. Where applicable, power dissipated in the headphone or line loads is included.

## POWER CONSUMPTION MEASUREMENTS

**Stereo Playback to Headphones** - DAC input to HPOUTL+HPOUTR pins with 30Ω load.

Test conditions

DACBIAS\_SEL = 01b (Normal bias x 0.5)

DACVMID\_BIAS\_SEL = 11b (Normal bias x 0.75)

PGA\_BIAS = 011b (Normal bias x 0.5)

CP\_DYN\_PWR = 1b (Charge pump controlled by real-time audio level)

Variant test conditions	AVDD		DCVDD		DBVDD		CPVDD		TOTAL
	V	mA	V	mA	V	mA	V	mA	mW
Slave mode, 44.1kHz sample rate, quiescent	1.8	1.60	1.2	0.76	1.8	0.00	1.8	0.41	4.5
Master mode, 44.1kHz sample rate, quiescent	1.8	1.60	1.2	0.76	1.8	0.09	1.8	0.41	4.7
Master mode, 44.1kHz, P <sub>o</sub> = 0.1mW/channel	1.8	1.60	1.2	0.90	1.8	0.09	1.8	1.85	7.5
Master mode, 44.1kHz, P <sub>o</sub> = 1mW/channel	1.8	1.60	1.2	0.92	1.8	0.09	1.8	5.77	14.5
Master mode, 8kHz sample rate, quiescent	1.8	1.60	1.2	0.65	1.8	0.03	1.8	0.41	4.4
Master mode, 8kHz, P <sub>o</sub> = 0.1mW/channel	1.8	1.60	1.2	0.71	1.8	0.03	1.8	1.85	7.1

**Stereo Playback to Line-out** - DAC input to LINEOUTL+LINEOUTR or HPOUTL+HPOUTR pins with 3.01k $\Omega$  / 50pF load

Test conditions:

CP\_DYN\_PWR = 1b (Charge pump controlled by real-time audio level)

Variant test conditions	AVDD		DCVDD		DBVDD		CPVDD		TOTAL
	V	mA	V	mA	V	mA	V	mA	mW
44.1kHz sample rate	1.8	1.95	1.2	0.76	1.8	0.09	1.8	0.32	5.2
8kHz sample rate	1.8	1.95	1.2	0.68	1.8	0.03	1.8	0.32	4.9

**Stereo analogue bypass to headphones** - IN1L/R or IN2L/R pins to HPOUTL+HPOUTR pins with 30 $\Omega$  load.

Test conditions: Audio interface disabled

Note that the Analogue bypass configuration does not benefit from the Class W dynamic control, and the power consumption is greater in this case than the DAC to Line-Out case. See "Charge Pump" section.

Variant test conditions	AVDD		DCVDD		DBVDD		CPVDD		TOTAL
	V	mA	V	mA	V	mA	V	mA	mW
Quiescent	1.8	1.46	1.2	0.12	1.8	0.00	1.8	1.54	5.5
P <sub>o</sub> = 0.1mW/channel	1.8	1.46	1.2	0.12	1.8	0.00	1.8	4.54	11.0

**Off**

Test conditions: No Clocks applied

Variant test conditions	AVDD		DCVDD		DBVDD		CPVDD		TOTAL
	V	mA	V	mA	V	mA	V	mA	mW
None	1.8	0.01	1.0	0.012	1.8	0.003	1.8	0.005	0.047

## SIGNAL TIMING REQUIREMENTS

### COMMON TEST CONDITIONS

Unless otherwise stated, the following test conditions apply throughout the following sections:

- Ambient temperature = +25°C
- DCVDD = 1.0V
- DBVDD = AVDD = CPVDD = 1.8V
- DGND = AGND = CPGND = 0V

Additional, specific test conditions are given within the relevant sections below.

### MASTER CLOCK

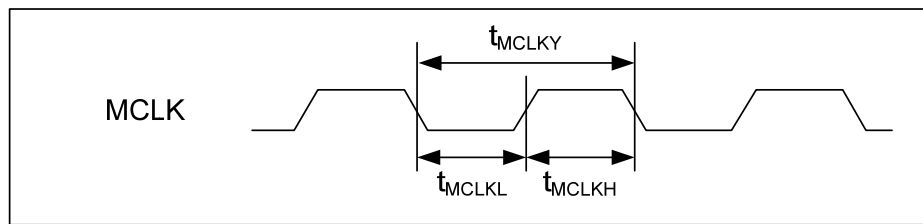
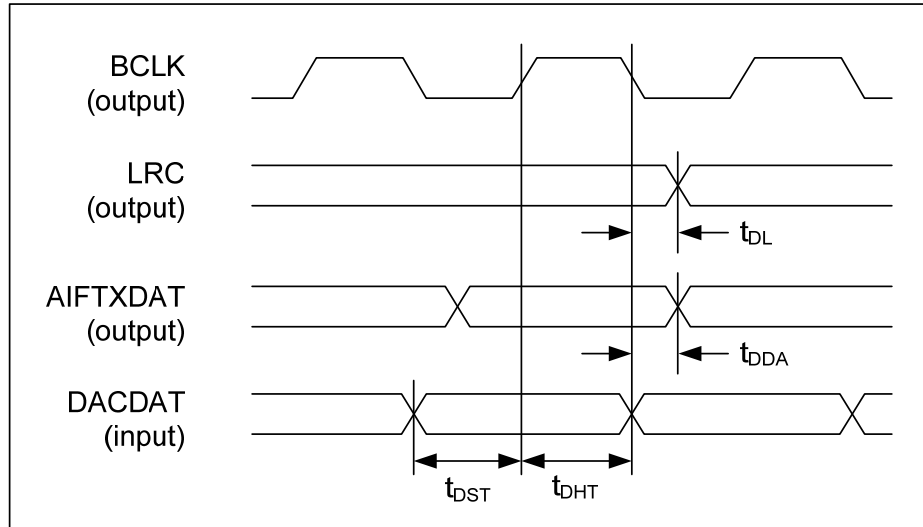

Figure 1 Master Clock Timing

Master Clock Timing						
PARAMETER	SYMBOL	TEST CONDITIONS	MIN	TYP	MAX	UNIT
MCLK cycle time	$T_{MCLKY}$	MCLKDIV2=1	40			ns
		MCLKDIV2=0	80			ns
MCLK cycle time	$T_{MCLKY}$	DCVDD ≥ 1.62V MCLKDIV2=0	54.25			ns
MCLK duty cycle	$T_{MCLKDS}$		60:40		40:60	

**AUDIO INTERFACE TIMING**

**MASTER MODE**



**Figure 2 Audio Interface Timing – Master Mode**

Audio Interface Timing – Master Mode					
PARAMETER	SYMBOL	MIN	TYP	MAX	UNIT
LRC propagation delay from BCLK falling edge	$t_{DL}$			10	ns
AIFTXDAT propagation delay from BCLK falling edge	$t_{DDA}$			10	ns
DACDAT setup time to BCLK rising edge	$t_{DST}$	10			ns
DACDAT hold time from BCLK rising edge	$t_{DHT}$	10			ns

SLAVE MODE

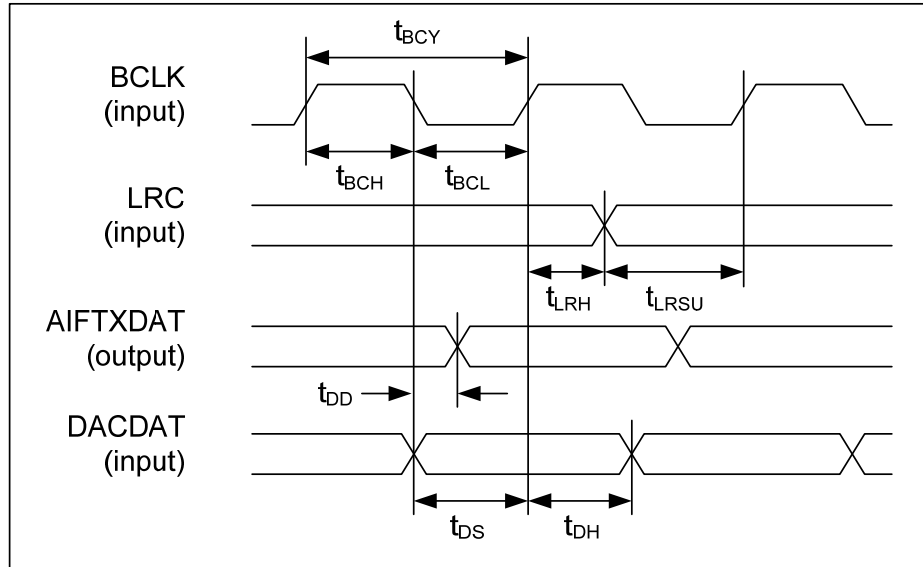

Figure 3 Audio Interface Timing – Slave Mode

Audio Interface Timing – Slave Mode					
PARAMETER	SYMBOL	MIN	TYP	MAX	UNIT
BCLK cycle time	$t_{BCY}$	50			ns
BCLK pulse width high	$t_{BCH}$	20			ns
BCLK pulse width low	$t_{BCL}$	20			ns
LRC set-up time to BCLK rising edge	$t_{LRSU}$	10			ns
LRC hold time from BCLK rising edge	$t_{LRH}$	10			ns
DACDAT hold time from BCLK rising edge	$t_{DH}$	10			ns
AIFTXDAT propagation delay from BCLK falling edge	$t_{DD}$			10	ns
DACDAT set-up time to BCLK rising edge	$t_{DS}$	20			ns

**Note:** BCLK period must always be greater than or equal to MCLK period.

**TDM MODE**

In TDM mode, it is important that two devices not attempt to drive the AIFTXDAT pin simultaneously. The timing of the WM8910 AIFTXDAT pin tri-stating at the start and end of the data transmission is described below.

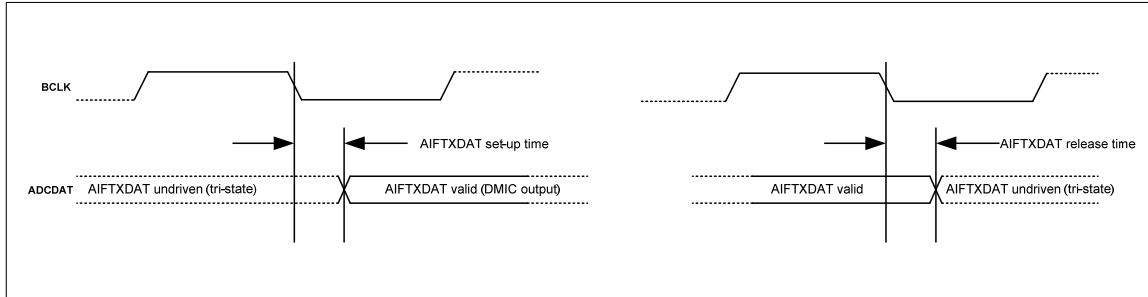

**Figure 4 Audio Interface Timing – TDM Mode**

Audio Interface Timing – TDM Mode					
PARAMETER	SYMBOL	MIN	TYP	MAX	UNIT
AIFTXDAT setup time from BCLK falling edge			4		ns
AIFTXDAT release time from BCLK falling edge			25		ns

## CONTROL INTERFACE TIMING

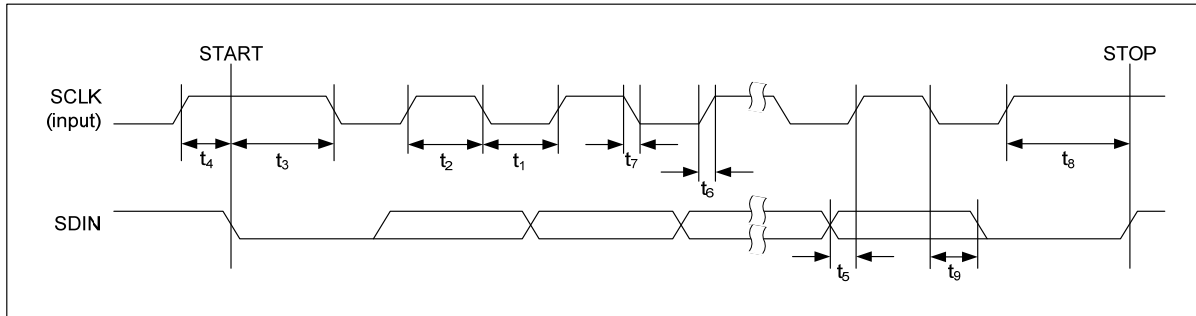

Figure 5 Control Interface Timing

Control Interface Timing					
PARAMETER	SYMBOL	MIN	TYP	MAX	UNIT
SCLK Frequency				526	kHz
SCLK Low Pulse-Width	$t_1$	1.3			$\mu$ s
SCLK High Pulse-Width	$t_2$	600			ns
Hold Time (Start Condition)	$t_3$	600			ns
Setup Time (Start Condition)	$t_4$	600			ns
Data Setup Time	$t_5$	100			ns
SDIN, SCLK Rise Time	$t_6$			300	ns
SDIN, SCLK Fall Time	$t_7$			300	ns
Setup Time (Stop Condition)	$t_8$	600			ns
Data Hold Time	$t_9$			900	ns
Pulse width of spikes that will be suppressed	$t_{ps}$	0		5	ns

**DIGITAL FILTER CHARACTERISTICS**

PARAMETER	TEST CONDITIONS	MIN	TYP	MAX	UNIT
<b>DAC Normal Filter</b>					
Passband	+/- 0.05dB	0		0.454 fs	
	-6dB		0.5 fs		
Passband Ripple	0.454 fs			+/- 0.03	dB
Stopband		0.546 fs			
Stopband Attenuation	F > 0.546 fs	-50			dB
<b>DAC Sloping Stopband Filter</b>					
Passband	+/- 0.03dB	0		0.25 fs	
	+/- 1dB	0.25 fs		0.454 fs	
	-6dB		0.5 fs		
Passband Ripple	0.25 fs			+/- 0.03	dB
Stopband 1		0.546 fs		0.7 fs	
Stopband 1 Attenuation	f > 0.546 fs	-60			dB
Stopband 2		0.7 fs		1.4 fs	
Stopband 2 Attenuation	f > 0.7 fs	-85			dB
Stopband 3		1.4 fs			
Stopband 3 Attenuation	F > 1.4 fs	-55			dB

DAC FILTERS	
Mode	Group Delay
Normal	16.5 / fs
Sloping Stopband	18 / fs

**TERMINOLOGY**

1. Stop Band Attenuation (dB) – the degree to which the frequency spectrum is attenuated (outside audio band)
2. Pass-band Ripple – any variation of the frequency response in the pass-band region

**DAC FILTER RESPONSES**

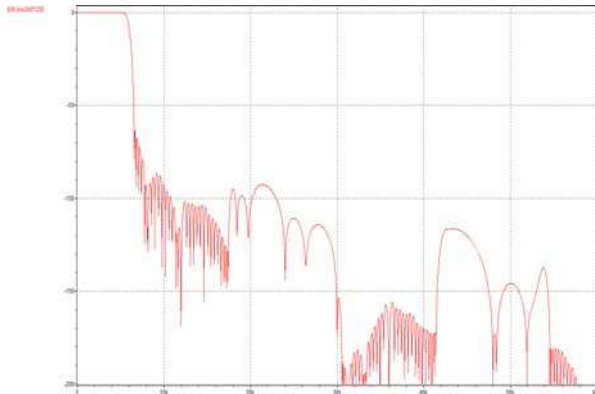

**Figure 6 DAC Filter Response for  
CLK\_SYS\_MODE = 10b (Clock is  $250 \times f_s$  related)  
DAC\_SB\_FILT = 1b (Sloping StopBand Filter)  
Sample Rate  $\leq 24\text{kHz}$**

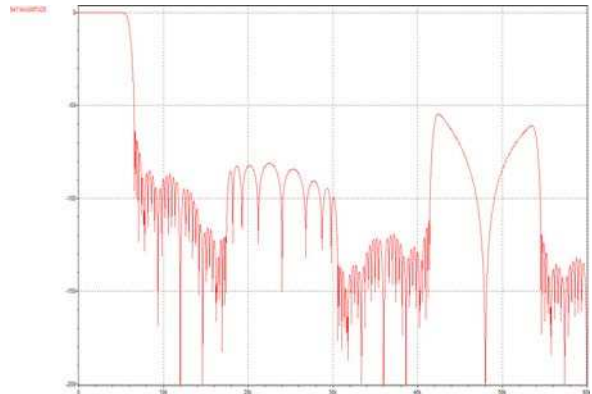

**Figure 7 DAC Filter Response for  
CLK\_SYS\_MODE = 00b or 01b  
DAC\_SB\_FILT = 1b (Sloping StopBand Filter)  
Sample Rate  $\leq 24\text{kHz}$**

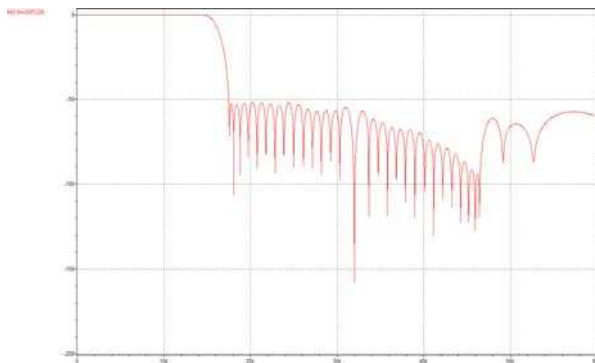

**Figure 8 DAC Filter Response for  
CLK\_SYS\_MODE = 10b (Clock is  $250 \times f_s$  related)  
DAC\_SB\_FILT = 0b (Normal Filter)  
Sample Rate  $> 24\text{kHz}$  (except  $88.2\text{kHz}$ )**

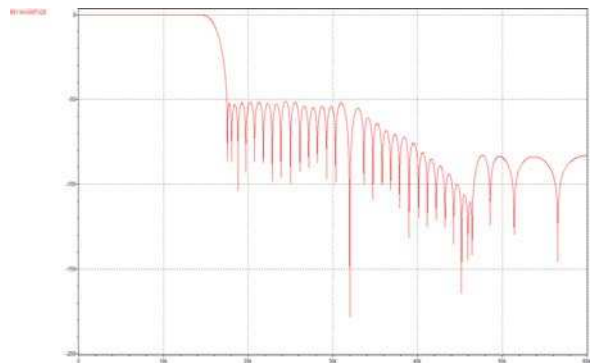

**Figure 9 DAC Filter Response for  
CLK\_SYS\_MODE = 00b or 01b  
DAC\_SB\_FILT = 0b (Normal Filter)  
Sample Rate  $> 24\text{kHz}$**

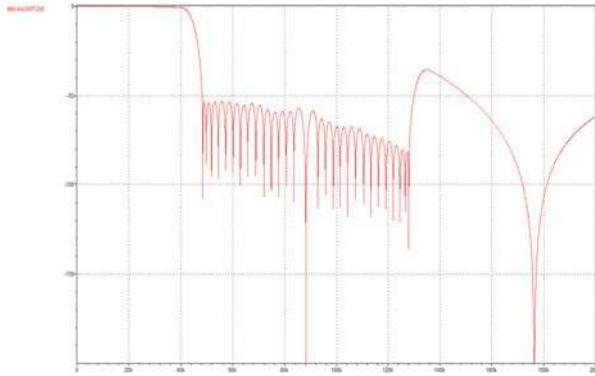

**Figure 10 DAC Filter Response for**  
**CLK\_SYS\_MODE = 01b (Clock is 272 x fs related)**  
**DAC\_SB\_FILT = 0b (Normal Filter)**  
**Sample Rate = 88.2kHz**

DE-EMPHASIS FILTER RESPONSES

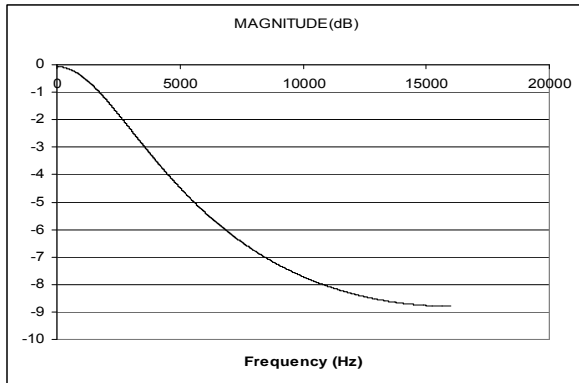

Figure 11 De-Emphasis Digital Filter Response (32kHz)

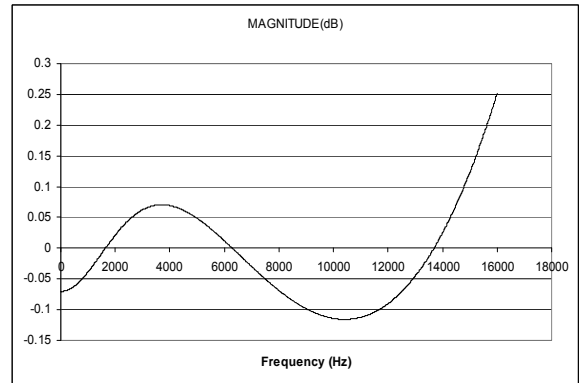

Figure 12 De-Emphasis Error (32kHz)

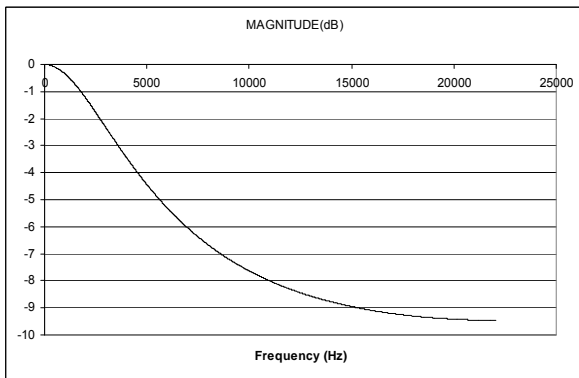

Figure 13 De-Emphasis Digital Filter Response (44.1kHz)

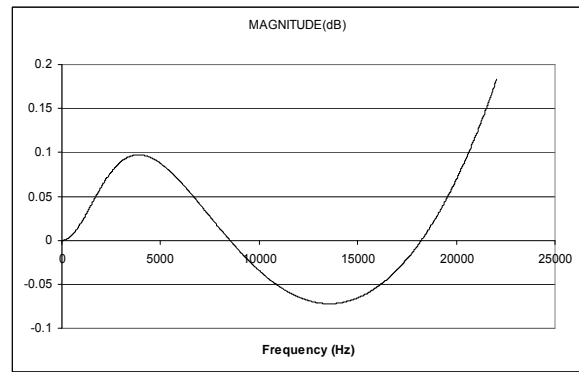

Figure 14 De-Emphasis Error (44.1kHz)

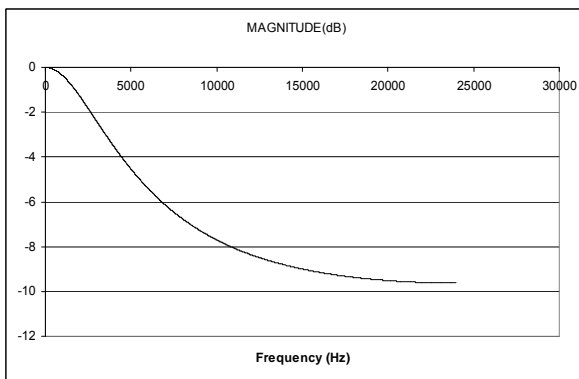

Figure 15 De-Emphasis Digital Filter Response (48kHz)

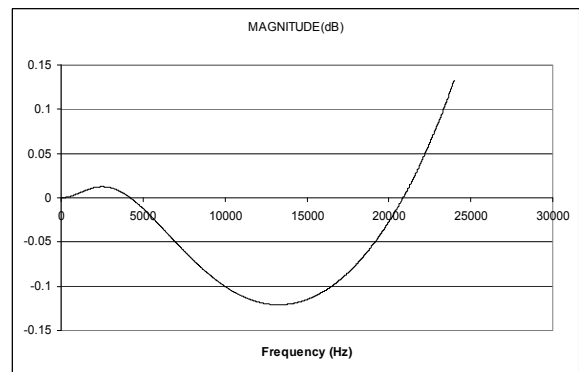

Figure 16 De-Emphasis Error (48kHz)

## DEVICE DESCRIPTION

### INTRODUCTION

The WM8910 is a high performance ultra-low power stereo DAC optimised for portable audio applications. Flexible analogue interfaces and powerful digital signal processing (DSP) make it ideal for small portable devices.

The WM8910 supports up to 4 analogue audio inputs. One pair of single-ended or differential microphone/line inputs is selected as the analogue input source.

A two-channel digital microphone interface is also supported, with direct input to the DSP core.

Two pairs of ground-referenced Class W headphone / line outputs are provided; these are powered from an integrated Charge Pump, enabling high quality, power efficient headphone playback without any requirement for DC blocking capacitors. A DC Servo circuit is available for DC offset correction, thereby suppressing pops and reducing power consumption. Two differential line outputs are also provided; these are also capable of driving external speaker drivers. Ground loop feedback is available on the ground-referenced headphone and line outputs, providing rejection of noise on the ground connections. All outputs use Wolfson SilentSwitch™ technology for pop and click suppression.

The stereo DACs are of hi-fi quality, using a 24-bit low-order oversampling architecture to deliver optimum performance. A digital mixing path from the Digital Microphone input to the DAC provides a sidetone of enhanced quality during voice calls. DAC soft mute and un-mute is available for pop-free music playback.

The integrated Dynamic Range Controller (DRC) provides further processing capability of the digital audio paths. The DRC provides compression and signal level control to improve the handling of unpredictable signal levels. 'Anti-clip' and 'quick release' algorithms improve intelligibility in the presence of transients and impulsive noises.

The WM8910 has a highly flexible digital audio interface, supporting a number of protocols, including I2S, DSP, MSB-first left/right justified, and can operate in master or slave modes. PCM operation is supported in the DSP mode. A-law and  $\mu$ -law companding are also supported. Time division multiplexing (TDM) is available to allow multiple devices to stream data simultaneously on the same bus, saving space and power.

The system clock CLK\_SYS provides clocking for the Digital Microphone, DACs, DSP core, digital audio interface and other circuits. CLK\_SYS can be derived directly from the MCLK pin or via an integrated FLL, providing flexibility to support a wide range of clocking schemes. Typical portable system MCLK frequencies, and sample rates from 8kHz to 48kHz are all supported. DAC operation at 88.2kHz and 96kHz is also possible. The clocking circuits are configured automatically from the sample rate (fs) and from the CLK\_SYS / fs ratio.

The integrated FLL can be used to generate CLK\_SYS from a wide variety of different reference sources and frequencies. The FLL can accept a wide range of reference frequencies, which may be high frequency (e.g. 13MHz) or low frequency (eg. 32.768kHz). The FLL is tolerant of jitter and may be used to generate a stable CLK\_SYS from a less stable input signal. The integrated FLL can be used as a free-running oscillator, enabling autonomous clocking of the Charge Pump and DC Servo if required.

The WM8910 uses a standard 2-wire control interface, providing full software control of all features, together with device register readback. An integrated Control Write Sequencer enables automatic scheduling of control sequences; commonly-used signal configurations may be selected using ready-programmed sequences, including time-optimised control of the WM8910 pop suppression features. It is an ideal partner for a wide range of industry standard microprocessors, controllers and DSPs. Unused circuitry can be disabled under software control, in order to save power; low leakage currents enable extended standby/off time in portable battery-powered applications.

Up to 5 GPIO pins may be configured for miscellaneous input/output functions such as button/accessory detect inputs, or for clock, system status, or programmable logic level output for control of additional external circuitry. Interrupt logic, status readback and de-bouncing options are supported within this functionality.

**ANALOGUE INPUT SIGNAL PATH**

The WM8910 has four analogue input pins, which may be used to support connections to multiple microphone or line input sources. The input multiplexer on the Left and Right channels can be used to select different configurations for each of the input sources. The analogue input paths can support line and microphone inputs, in single-ended and differential modes. The input stage can also provide common mode noise rejection in some configurations.

The Left and Right analogue input channels are routed directly to the output mixers.

The WM8910 input signal paths and control registers are illustrated in Figure 17.

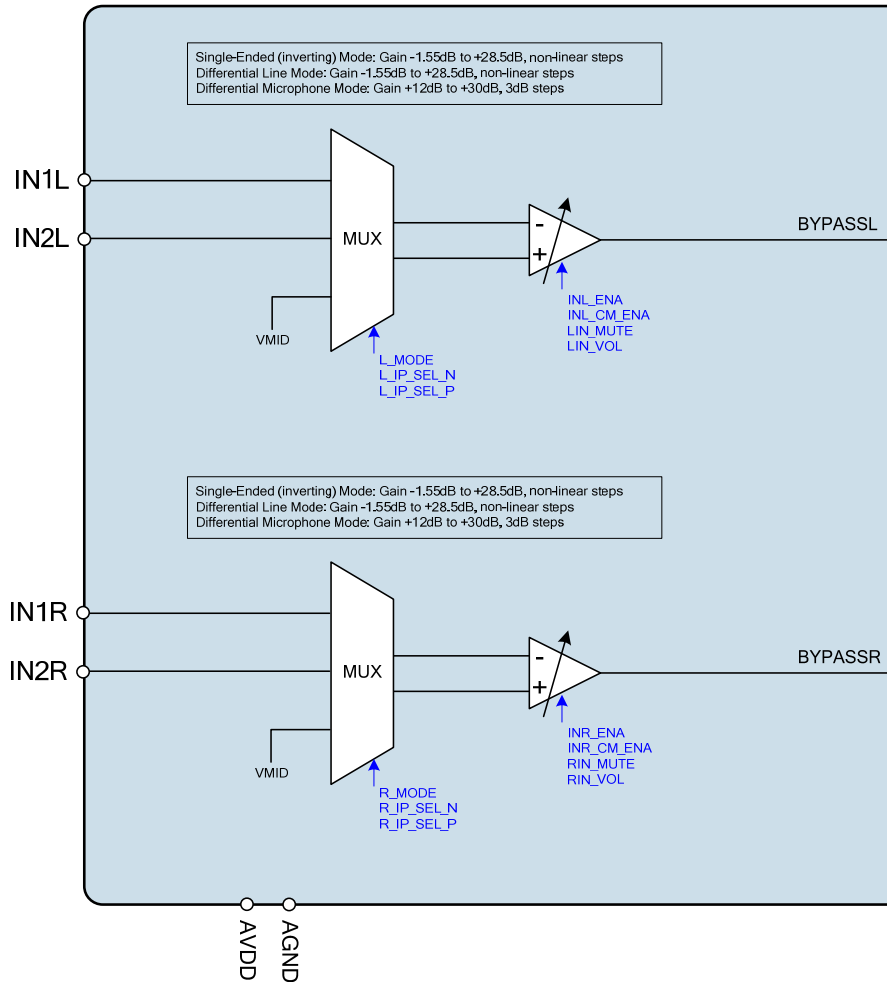

Figure 17 Block Diagram for Input Signal Path

**INPUT PGA ENABLE**

The input PGAs (Programmable Gain Amplifiers) and Multiplexers are enabled using register bits INL\_ENA and INR\_ENA, as shown in Table 1.

REGISTER ADDRESS	BIT	LABEL	DEFAULT	DESCRIPTION
R12 (0Ch) Power Management 0	1	INL_ENA	0	Left Input PGA Enable 0 = disabled 1 = enabled
	0	INR_ENA	0	Right Input PGA Enable 0 = disabled 1 = enabled

**Table 1 Input PGA Enable**

To enable the input PGAs, the reference voltage VMID and the bias current must also be enabled. See "Reference Voltages and Master Bias" for details of the associated controls VMID\_RES and BIAS\_ENA.

**INPUT PGA CONFIGURATION**

The analogue input channels can each be configured in three different modes, which are as follows:

- Single-Ended Mode (Inverting)
- Differential Line Mode
- Differential Mic Mode

The mode is selected by the L\_MODE and R\_MODE fields for the Left and Right channels respectively. The input pins are selected using the L\_IP\_SEL\_N and L\_IP\_SEL\_P fields for the Left channel and the R\_IP\_SEL\_N and R\_IP\_SEL\_P for the Right channel. In Single-Ended mode, L\_IP\_SEL\_N alone determines the Left Input pin, and the R\_IP\_SEL\_N determines the Right Input pin.

The three modes are illustrated in Figure 18, Figure 19 and Figure 20. It should be noted that the available gain and input impedance varies between configurations (see also "Electrical Characteristics"). The input impedance is constant with PGA gain setting.

The Input PGA modes are selected and configured using the register fields described in Table 2.

REGISTER ADDRESS	BIT	LABEL	DEFAULT	DESCRIPTION
R46 (2Eh) Analogue Left Input 1	5:4	L_IP_SEL_N [1:0]	00	In Single-Ended or Differential Line Modes, this field selects the input pin for the inverting side of the left input path.  In Differential Mic Mode, this field selects the input pin for the non-inverting side of the left input path.: 00 = IN1L 01 = IN2L 1X = Reserved
	3:2	L_IP_SEL_P [1:0]	01	In Single-Ended or Differential Line Modes, this field selects the input pin for the non-inverting side of the left input path.  In Differential Mic Mode, this field selects the input pin for the inverting side of the left input path. 00 = IN1L 01 = IN2L 1X = Reserved
	1:0	L_MODE [1:0]	00	Sets the mode for the left analogue input: 00 = Single-Ended 01 = Differential Line 10 = Differential MIC 11 = Reserved
R47 (2Fh) Analogue Right Input 1	5:4	R_IP_SEL_N [1:0]	00	In Single-Ended or Differential Line Modes, this field selects the input pin for the inverting side of the right input path.  In Differential Mic Mode, this field selects the input pin for the non-inverting side of the right input path. 00 = IN1R 01 = IN2R 1X = Reserved
	3:2	R_IP_SEL_P [1:0]	01	In Single-Ended or Differential Line Modes, this field selects the input pin for the non-inverting side of the right input path.  In Differential Mic Mode, this field selects the input pin for the inverting side of the right input path. 00 = IN1R 01 = IN2R 1X = Reserved
	1:0	R_MODE [1:0]	00	Sets the mode for the right analogue input: 00 = Single-Ended 01 = Differential Line 10 = Differential MIC 11 = Reserved

Table 2 Input PGA Mode Selection

**SINGLE-ENDED INPUT**

The Single-Ended PGA configuration is illustrated in Figure 18 for the Left channel. The available gain in this mode is from -1.55dB to +28.5dB in non-linear steps. The input impedance is 12kΩ. The PGA output is phase inverted with respect to the selected input pin. Different input pins can be selected in the same mode by altering the L\_IP\_SEL\_N field.

The equivalent configuration is also available on the Right channel; this can be selected independently of the Left channel mode.

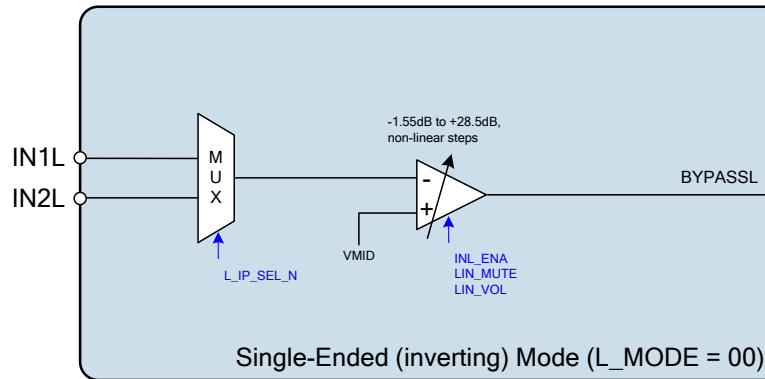

Figure 18 Single Ended Mode

**DIFFERENTIAL LINE INPUT**

The Differential Line PGA configuration is illustrated in Figure 19 for the Left channel. The available gain in this mode is from -1.55dB to +28.5dB in non-linear steps. The input impedance is 12kΩ. The PGA output is in phase with the input pin selected by L\_IP\_SEL\_P. The PGA output is phase inverted with respect to the input pin selected by L\_IP\_SEL\_N.

As an option, common mode noise rejection can be provided in this PGA configuration, as illustrated in Figure 19. This is enabled using the register bits defined in Table 5.

The equivalent configuration is also available on the Right channel; this can be selected independently of the Left channel mode.

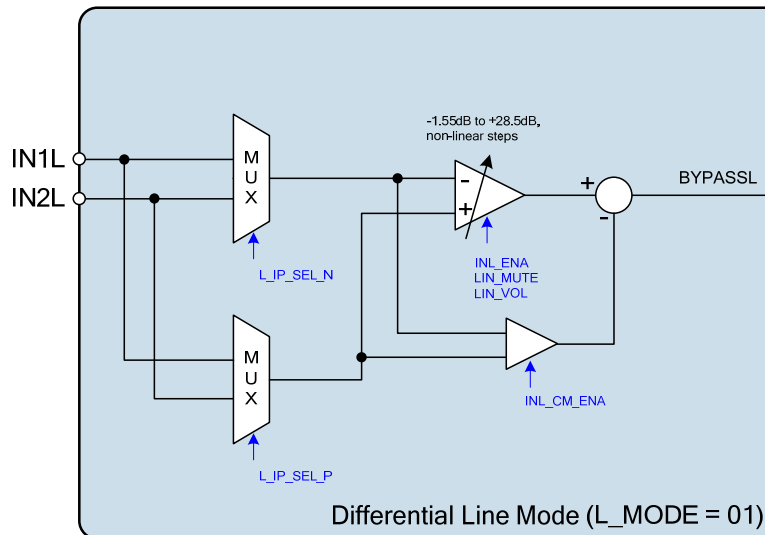

Figure 19 Differential Line Mode

### DIFFERENTIAL MICROPHONE INPUT

The Differential Mic PGA configuration is illustrated in Figure 20 for the Left channel. The available gain in this mode is from +12dB to +30dB in 3dB linear steps. The input impedance is 120k $\Omega$ . The PGA output is in phase with the input pin selected by L\_IP\_SEL\_N. The PGA output is phase inverted with respect to the input pin selected by L\_IP\_SEL\_P.

Note that the inverting input pin is selected using L\_IP\_SEL\_P and the non-inverting input pin is selected using L\_IP\_SEL\_N. This is not the same as for the Differential Line mode.

The equivalent configuration is also available on the Right channel; this can be selected independently of the Left channel mode.

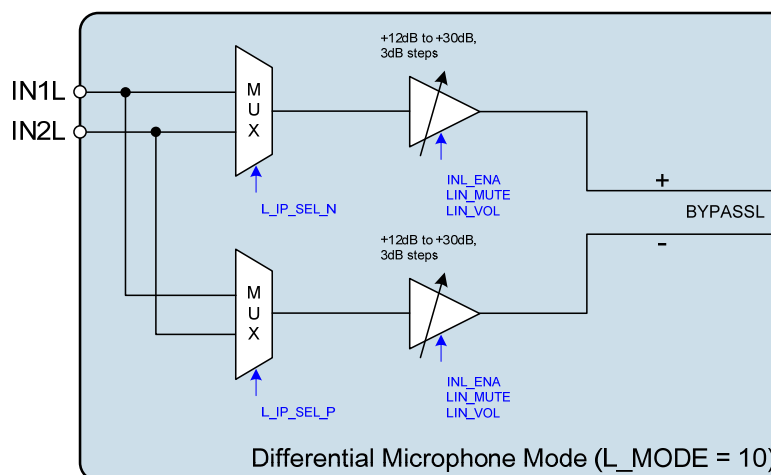

Figure 20 Differential Microphone Mode

### INPUT PGA GAIN CONTROL

The volume control gain for the Left and Right channels be independently controlled using the LIN\_VOL and RIN\_VOL register fields as described in Table 3. The available gain range varies according to the selected PGA Mode as detailed in Table 4. Note that the value '00000' must not be used in Differential Mic Mode, as the PGA will not function correctly under this setting. In single-ended mode (L\_MODE / R\_MODE = 00b), the conversion from single-ended to differential within the WM8910 adds a further 6dB of gain to the signal path.

Each input channel can be independently muted using LINMUTE and RINMUTE.

It is recommended to not adjust the gain dynamically whilst the signal path is enabled; the signal should be muted at the input or output stage prior to adjusting the volume control.

REGISTER ADDRESS	BIT	LABEL	DEFAULT	DESCRIPTION
R44 (2Ch) Analogue Left Input 0	7	LINMUTE	1	Left Input PGA Mute 0 = not muted 1 = muted
	4:0	LIN_VOL [4:0]	00101	Left Input PGA Volume (See Table 4 for volume range)
R45 (2Dh) Analogue Right Input 0	7	RINMUTE	1	Right Input PGA Mute 0 = not muted 1 = muted
	4:0	RIN_VOL [4:0]	00101	Right Input PGA Volume (See Table 4 for volume range)

Table 3 Input PGA Volume Control

LIN_VOL [4:0], RIN_VOL [4:0]	GAIN – SINGLE-ENDED MODE / DIFFERENTIAL LINE MODE	GAIN – DIFFERENTIAL MIC MODE
00000	-1.55 dB	Not valid
00001	-1.3 dB	+12 dB
00010	-1.0 dB	+15 dB
00011	-0.7 dB	+18 dB
00100	-0.3 dB	+21 dB
00101	0.0 dB	+24 dB
00110	+0.3 dB	+27 dB
00111	+0.7 dB	+30 dB
01000	+1.0 dB	+30 dB
01001	+1.4 dB	+30 dB
01010	+1.8 dB	+30 dB
01011	+2.3 dB	+30 dB
01100	+2.7 dB	+30 dB
01101	+3.2 dB	+30 dB
01110	+3.7 dB	+30 dB
01111	+4.2 dB	+30 dB
10000	+4.8 dB	+30 dB
10001	+5.4 dB	+30 dB
10010	+6.0 dB	+30 dB
10011	+6.7 dB	+30 dB
10100	+7.5 dB	+30 dB
10101	+8.3 dB	+30 dB
10110	+9.2 dB	+30 dB
10111	+10.2 dB	+30 dB
11000	+11.4 dB	+30 dB
11001	+12.7 dB	+30 dB
11010	+14.3 dB	+30 dB
11011	+16.2 dB	+30 dB
11100	+19.2 dB	+30 dB
11101	+22.3 dB	+30 dB
11110	+25.2 dB	+30 dB
11111	+28.3 dB	+30 dB

Table 4 Input PGA Volume Range

### INPUT PGA COMMON MODE AMPLIFIER

In Differential Line Mode only, a Common Mode amplifier can be enabled as part of the input PGA circuit. This feature provides approximately 20dB reduction in common mode noise on the differential input, which can reduce problematic interference. The presence of Common Mode noise can limit the usable signal range of the device; enabling the Common Mode amplifier can solve this issue.

It should be noted that the Common Mode amplifier consumes additional power and can also add its own noise to the input signal. For these reasons, it is recommended that the Common Mode Amplifier is only enabled if there is a known source of Common Mode interference.

The Common Mode amplifier is controlled by the INL\_CM\_ENA and INR\_CM\_ENA fields as described in Table 5. Although the Common Mode amplifier may be enabled regardless of the input PGA mode, its function is only effective in the Differential Line Mode configuration.

REGISTER ADDRESS	BIT	LABEL	DEFAULT	DESCRIPTION
R46 (2Eh) Analogue Left Input 1	6	INL_CM_ENA	1	Left Input PGA Common Mode Rejection enable 0 = Disabled 1 = Enabled (only available for L_MODE=01 – Differential Line)
R47 (2Fh) Analogue Right Input 1	6	INR_CM_ENA	1	Right Input PGA Common Mode Rejection enable 0 = Disabled 1 = Enabled (only available for R_MODE=01 – Differential Line)

Table 5 Common Mode Amplifier Enable

### DIGITAL MICROPHONE INTERFACE

The WM8910 supports a two-channel digital microphone interface. The two-channel audio data is multiplexed on the DMIC\_DAT input and clocked by the DMIC\_LR output.

The Digital Microphone Input, DMIC\_DAT, can be enabled on GPIO2, GPIO3, IN1L or IN1R, using the DIGMIC\_SEL register field. The Digital Microphone Clock, DMIC\_LR, can be enabled on any of the 5 GPIO pins.

The Digital Microphone Input is selected by setting the DMIC\_SEL bit. The Digital Microphone DSP functions are enabled by setting DMICL\_ENA and DMICR\_ENA for the left and right channels respectively.

The Digital Microphone Interface configuration is illustrated in Figure 21.

Note that that care must be taken to ensure that the respective digital logic levels of the microphone are compatible with the digital input thresholds of the WM8910. The digital input thresholds are referenced to DBVDD, as defined in "Electrical Characteristics". It is recommended to power the digital microphones from the same DBVDD supply as WM8910.

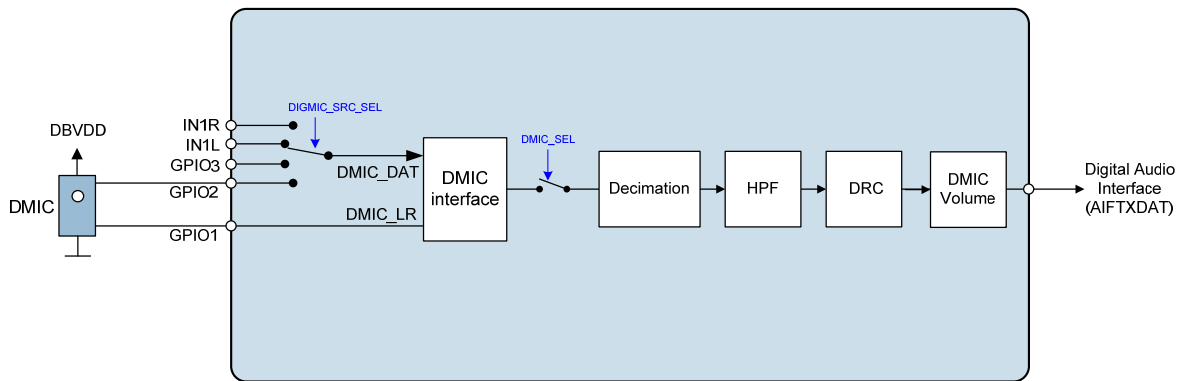

Figure 21 Digital Microphone Interface Control

When a GPIO pin is configured as DMIC\_LR Clock output, the WM8910 outputs a clock which supports Digital Mic operation at a multiple of the DAC sampling rate, in the range 1-3MHz. The Digital Microphone DSP must be enabled (see Table 6) and the DAC sampling rate must be set in order to ensure correct operation of all DSP functions associated with the digital microphone. Volume control for the Digital Microphone Interface signals is provided using the registers described in Table 7.

See "General Purpose Input/Output (GPIO)" for details of configuring the DMIC\_LR and DMIC\_DAT functions. See "Clocking and Sample Rates" for the details of the supported clocking configurations.

When GPIO2, GPIO3, IN1L or IN1R is configured as DMIC\_DAT input, this pin is the digital microphone input. Up to two microphones can share this pin; the two microphones are interleaved as illustrated in Figure 22.

The digital microphone interface requires that MIC1 transmits a data bit each time that DMIC\_LR is high, and MIC2 transmits when DMIC\_LR is low. The WM8910 samples the digital microphone data in the middle of each DMIC\_LR clock phase. Each microphone must tri-state its data output when the other microphone is transmitting.

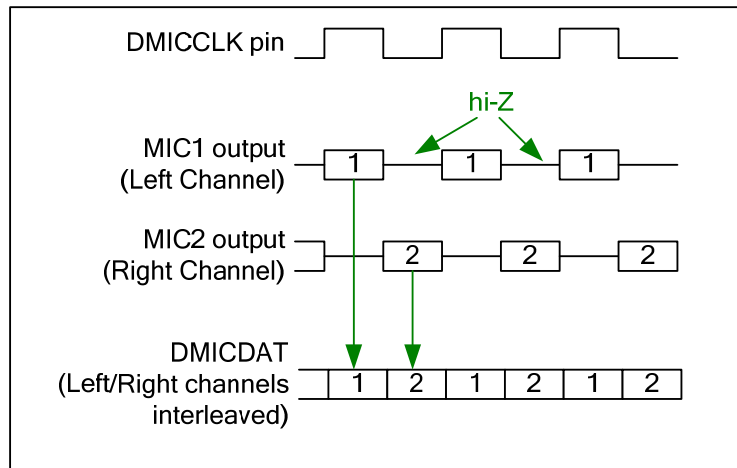

Figure 22 Digital Microphone Interface Timing

The digital microphone interface control fields are described in Table 6.

REGISTER ADDRESS	BIT	LABEL	DEFAULT	DESCRIPTION
R18 (12h) Power Management 6	1	DMICL_ENA	0	Digital Microphone DSP Enable 0 = disabled 1 = enabled
	0	DMICR_ENA	0	Digital Microphone DSP Enable 0 = disabled 1 = enabled
R39 (27h) Digital Microphone 0	10:9	DIGMIC_SRC_SEL [1:0]	00	Digital Microphone Data Select 00 = GPIO2 01 = GPIO3 10 = IN1L 11 = IN2R
R164 (A4h) Clock Rate Test 4	9	DMIC_SEL	0	Digital Microphone mode. 0 = Disabled 1 = Audio DSP input is from digital microphone interface

**Table 6 Digital Microphone Interface Control**

Note that, in addition to setting the registers described in Table 6, the selected GPIO pins (GPIO1, GPIO2 or GPIO3) must also be configured to provide the digital microphone interface function. See "General Purpose Input/Output (GPIO)" for details. Note that selecting DMIC\_DAT on the IN1L or IN1R pin causes that pin to be disconnected from the analogue input PGA circuits.

Note that all the GPIO pins are referenced to the DBVDD power domain; the IN1L and IN1R pins are referenced to the AVDD power domain. Care must be taken to ensure the microphone logic levels are compatible with the applicable power domain.

### DIGITAL MICROPHONE VOLUME CONTROL

The output of the Digital Microphone DSP can be digitally amplified or attenuated over a range from -71.625dB to +17.625dB in 0.375dB steps. The volume of each channel can be controlled separately. The gain for a given eight-bit code is detailed in Table 8.

The DMICVU bit controls the loading of digital volume control data. When DMICVU is set to 0, the DMICL\_VOL or DMICR\_VOL control data is loaded into the respective control register, but does not actually change the digital gain setting. Both left and right gain settings are updated when a 1 is written to DMICVU. This makes it possible to update the gain of both channels simultaneously.

REGISTER ADDRESS	BIT	LABEL	DEFAULT	DESCRIPTION
R36 (24h) DMIC Digital Volume Left	8	DMICVU	N/A	Digital Microphone Volume Update Writing a 1 to this bit causes left and right DMIC volume to be updated simultaneously
	7:0	DMICL_VOL [7:0]	1100_0000 (0dB)	Left Digital Microphone Volume 00h = Mute 01h = -71.625dB 02h = -71.250dB ... (0.375dB steps) C0h = 0dB ... (0.375dB steps) EFh to FFh = +17.625dB (See Table 8 for volume range)
R37 (25h) DMIC Digital Volume Right	8	DMICVU	N/A	Digital Microphone Volume Update Writing a 1 to this bit causes left and right DMIC volume to be updated simultaneously
	7:0	DMICR_VOL [7:0]	1100_0000 (0dB)	Right Digital Microphone Volume 00h = Mute 01h = -71.625dB 02h = -71.250dB ... (0.375dB steps) C0h = 0dB ... (0.375dB steps) EFh to FFh = +17.625dB (See Table 8 for volume range)

Table 7 Digital Microphone Volume Control

DMICL_VOL or DMICR_VOL	Volume (dB)	DMICL_VOL or DMICR_VOL	Volume (dB)	DMICL_VOL or DMICR_VOL	Volume (dB)	DMICL_VOL or DMICR_VOL	Volume (dB)
0h	MUTE	40h	-48.000	80h	-24.000	C0h	0.000
1h	-71.625	41h	-47.625	81h	-23.625	C1h	0.375
2h	-71.250	42h	-47.250	82h	-23.250	C2h	0.750
3h	-70.875	43h	-46.875	83h	-22.875	C3h	1.125
4h	-70.500	44h	-46.500	84h	-22.500	C4h	1.500
5h	-70.125	45h	-46.125	85h	-22.125	C5h	1.875
6h	-69.750	46h	-45.750	86h	-21.750	C6h	2.250
7h	-69.375	47h	-45.375	87h	-21.375	C7h	2.625
8h	-69.000	48h	-45.000	88h	-21.000	C8h	3.000
9h	-68.625	49h	-44.625	89h	-20.625	C9h	3.375
Ah	-68.250	4Ah	-44.250	8Ah	-20.250	CAh	3.750
Bh	-67.875	4Bh	-43.875	8Bh	-19.875	CBh	4.125
Ch	-67.500	4Ch	-43.500	8Ch	-19.500	CCh	4.500
Dh	-67.125	4Dh	-43.125	8Dh	-19.125	CDh	4.875
Eh	-66.750	4Eh	-42.750	8Eh	-18.750	CEh	5.250
Fh	-66.375	4Fh	-42.375	8Fh	-18.375	CFh	5.625
10h	-66.000	50h	-42.000	90h	-18.000	D0h	6.000
11h	-65.625	51h	-41.625	91h	-17.625	D1h	6.375
12h	-65.250	52h	-41.250	92h	-17.250	D2h	6.750
13h	-64.875	53h	-40.875	93h	-16.875	D3h	7.125
14h	-64.500	54h	-40.500	94h	-16.500	D4h	7.500
15h	-64.125	55h	-40.125	95h	-16.125	D5h	7.875
16h	-63.750	56h	-39.750	96h	-15.750	D6h	8.250
17h	-63.375	57h	-39.375	97h	-15.375	D7h	8.625
18h	-63.000	58h	-39.000	98h	-15.000	D8h	9.000
19h	-62.625	59h	-38.625	99h	-14.625	D9h	9.375
1Ah	-62.250	5Ah	-38.250	9Ah	-14.250	DAh	9.750
1Bh	-61.875	5Bh	-37.875	9Bh	-13.875	DBh	10.125
1Ch	-61.500	5Ch	-37.500	9Ch	-13.500	DCh	10.500
1Dh	-61.125	5Dh	-37.125	9Dh	-13.125	DDh	10.875
1Eh	-60.750	5Eh	-36.750	9Eh	-12.750	DEh	11.250
1Fh	-60.375	5Fh	-36.375	9Fh	-12.375	DFh	11.625
20h	-60.000	60h	-36.000	A0h	-12.000	E0h	12.000
21h	-59.625	61h	-35.625	A1h	-11.625	E1h	12.375
22h	-59.250	62h	-35.250	A2h	-11.250	E2h	12.750
23h	-58.875	63h	-34.875	A3h	-10.875	E3h	13.125
24h	-58.500	64h	-34.500	A4h	-10.500	E4h	13.500
25h	-58.125	65h	-34.125	A5h	-10.125	E5h	13.875
26h	-57.750	66h	-33.750	A6h	-9.750	E6h	14.250
27h	-57.375	67h	-33.375	A7h	-9.375	E7h	14.625
28h	-57.000	68h	-33.000	A8h	-9.000	E8h	15.000
29h	-56.625	69h	-32.625	A9h	-8.625	E9h	15.375
2Ah	-56.250	6Ah	-32.250	AAh	-8.250	EAh	15.750
2Bh	-55.875	6Bh	-31.875	ABh	-7.875	EBh	16.125
2Ch	-55.500	6Ch	-31.500	ACh	-7.500	ECh	16.500
2Dh	-55.125	6Dh	-31.125	ADh	-7.125	EDh	16.875
2Eh	-54.750	6Eh	-30.750	A Eh	-6.750	EEh	17.250
2Fh	-54.375	6Fh	-30.375	AFh	-6.375	EFh	17.625
30h	-54.000	70h	-30.000	B0h	-6.000	F0h	17.625
31h	-53.625	71h	-29.625	B1h	-5.625	F1h	17.625
32h	-53.250	72h	-29.250	B2h	-5.250	F2h	17.625
33h	-52.875	73h	-28.875	B3h	-4.875	F3h	17.625
34h	-52.500	74h	-28.500	B4h	-4.500	F4h	17.625
35h	-52.125	75h	-28.125	B5h	-4.125	F5h	17.625
36h	-51.750	76h	-27.750	B6h	-3.750	F6h	17.625
37h	-51.375	77h	-27.375	B7h	-3.375	F7h	17.625
38h	-51.000	78h	-27.000	B8h	-3.000	F8h	17.625
39h	-50.625	79h	-26.625	B9h	-2.625	F9h	17.625
3Ah	-50.250	7Ah	-26.250	BAh	-2.250	FAh	17.625
3Bh	-49.875	7Bh	-25.875	BBh	-1.875	FBh	17.625
3Ch	-49.500	7Ch	-25.500	BCh	-1.500	FCh	17.625
3Dh	-49.125	7Dh	-25.125	BDh	-1.125	FDh	17.625
3Eh	-48.750	7Eh	-24.750	BEh	-0.750	FEh	17.625
3Fh	-48.375	7Fh	-24.375	BFh	-0.375	FFh	17.625

Table 8 Digital Microphone Volume Range

## DYNAMIC RANGE CONTROL (DRC)

The dynamic range controller (DRC) is a circuit which can be enabled in the Digital Microphone input path. Its function is to adjust the signal gain in conditions where the input amplitude is unknown or varies over a wide range, e.g. when recording from microphones built into a handheld system. The DRC can apply Compression and Automatic Level Control to the signal path. It incorporates 'anti-clip' and 'quick release' features for handling transients in order to improve intelligibility in the presence of loud impulsive noises.

The DRC is enabled as shown in Table 9.

REGISTER ADDRESS	BIT	LABEL	DEFAULT	DESCRIPTION
R40 (28h) DRC 0	15	DRC_ENA	0	DRC enable 1 = enabled 0 = disabled

Table 9 DRC Enable

### COMPRESSION/LIMITING CAPABILITIES

The DRC supports two different compression regions, specified by R0 and R1, separated by a "knee" at input amplitude T. For signals above the knee, the compression slope R0 applies; for signals below the knee, the compression slope R1 applies.

The overall DRC compression characteristic in "steady state" (i.e. where the input amplitude is near-constant) is illustrated in Figure 23.

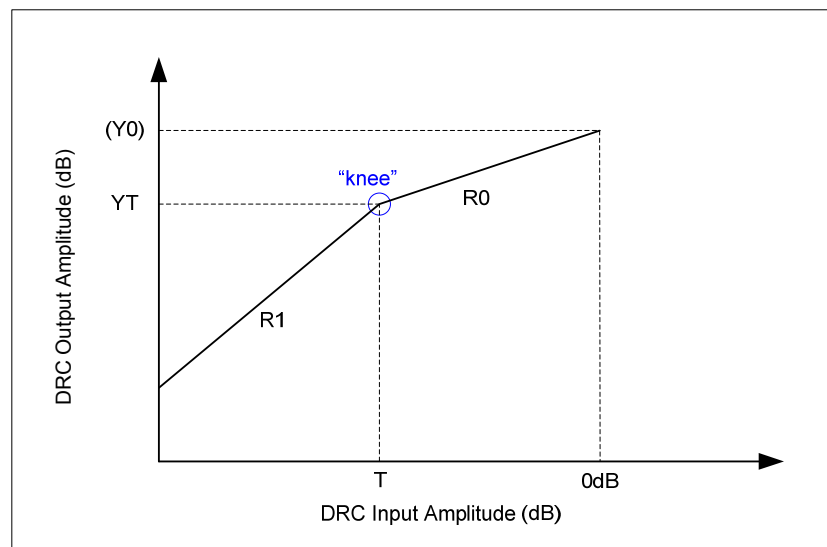

Figure 23 DRC Compression Characteristic

The slope of R0 and R1 are determined by register fields DRC\_R0\_SLOPE\_COMP and DRC\_R1\_SLOPE\_COMP respectively. A slope of 1 indicates constant gain in this region. A slope less than 1 represents compression (i.e. a change in input amplitude produces only a smaller change in output amplitude). A slope of 0 indicates that the target output amplitude is the same across a range of input amplitudes; this is infinite compression.

The "knee" in Figure 23 is represented by T and Y, which are determined by register fields DRC\_THRESH\_COMP and DRC\_AMP\_COMP respectively.

Parameter Y0, the output level for a 0dB input, is not specified directly, but can be calculated from the other parameters, using the equation

$$Y0 = YT - (T * R0)$$

The DRC Compression parameters are defined in Table 10.

REGISTER ADDRESS	BIT	LABEL	DEFAULT	DESCRIPTION
R42 (2Ah) DRC 2	5:3	DRC_R0_SLOP E_COMP [2:0]	100	Compressor slope R0 000 = 1 (no compression) 001 = 1/2 010 = 1/4 011 = 1/8 100 = 1/16 101 = 0 110 = Reserved 111 = Reserved
	2:0	DRC_R1_SLOP E_COMP [2:0]	000	Compressor slope R1 000 = 1 (no compression) 001 = 1/2 010 = 1/4 011 = 1/8 100 = 0 101 = Reserved 11X = Reserved
R43 (2Bh) DRC 3	10:5	DRC_THRESH_ COMP [5:0]	000000	Compressor threshold T (dB) 000000 = 0dB 000001 = -0.75dB 000010 = -1.5dB ... (-0.75dB steps) 111100 = -45dB 111101 = Reserved 11111X = Reserved
	4:0	DRC_AMP_CO MP [4:0]	00000	Compressor amplitude at threshold YT (dB) 00000 = 0dB 00001 = -0.75dB 00010 = -1.5dB ... (-0.75dB steps) 11110 = -22.5dB 11111 = Reserved

Table 10 DRC Compression Control

### GAIN LIMITS

The minimum and maximum gain applied by the DRC is set by register fields DRC\_MINGAIN and DRC\_MAXGAIN. These limits can be used to alter the DRC response from that illustrated in Figure 23. If the range between maximum and minimum gain is reduced, then the extent of the dynamic range control is reduced. The maximum gain prevents quiet signals (or silence) from being excessively amplified.

REGISTER ADDRESS	BIT	LABEL	DEFAULT	DESCRIPTION
R41 (29h) DRC 1	3:2	DRC_MINGAIN [1:0]	00	Minimum gain the DRC can use to attenuate audio signals 00 = 0dB (default) 01 = -6dB 10 = -12dB 11 = -18dB
	1:0	DRC_MAXGAIN [1:0]	01	Maximum gain the DRC can use to boost audio signals 00 = 12dB 01 = 18dB (default) 10 = 24dB 11 = 36dB

Table 11 DRC Gain Limits

### DYNAMIC CHARACTERISTICS

The dynamic behaviour determines how quickly the DRC responds to changing signal levels. Note that the DRC responds to the average (RMS) signal amplitude over a period of time.

The DRC\_ATTACK\_RATE determines how quickly the DRC gain decreases when the signal amplitude is high. The DRC\_DECAY\_RATE determines how quickly the DRC gain increases when the signal amplitude is low.

These register fields are described in Table 12. Note that the register defaults are suitable for general purpose microphone use.

REGISTER ADDRESS	BIT	LABEL	DEFAULT	DESCRIPTION
R41 (29h) DRC 1	15:12	DRC_ATTACK_RATE [3:0]	0011	Gain attack rate (seconds/6dB) 0000 = Reserved 0001 = 182µs 0010 = 363µs 0011 = 726µs (default) 0100 = 1.45ms 0101 = 2.9ms 0110 = 5.8ms 0111 = 11.6ms 1000 = 23.2ms 1001 = 46.4ms 1010 = 92.8ms 1011-1111 = Reserved
	11:8	DRC_DECAY_RATE [3:0]	0010	Gain decay rate (seconds/6dB) 0000 = 186ms 0001 = 372ms 0010 = 743ms (default) 0011 = 1.49s 0100 = 2.97s 0101 = 5.94s 0110 = 11.89s 0111 = 23.78s 1000 = 47.56s 1001-1111 = Reserved

Table 12 DRC Attack and Decay Rates

**Note:**

For detailed information about DRC attack and decay rates, please see Wolfson application note WAN0247.

**ANTI-CLIP CONTROL**

The DRC includes an Anti-Clip feature to avoid signal clipping when the input amplitude rises very quickly. This feature uses a feed-forward technique for early detection of a rising signal level. Signal clipping is avoided by dynamically increasing the gain attack rate when required. The Anti-Clip feature is enabled using the DRC\_ANTICLIP\_ENA bit.

Note that the feed-forward processing increases the latency in the input signal path. For low-latency applications (e.g. telephony), it may be desirable to reduce the delay, although this will also reduce the effectiveness of the anti-clip feature. The latency is determined by the DRC\_FF\_DELAY bit. If necessary, the latency can be minimised by disabling the anti-clip feature altogether.

The DRC Anti-Clip control bits are described in Table 13.

REGISTER ADDRESS	BIT	LABEL	DEFAULT	DESCRIPTION
R40 (28h) DRC 0	5	DRC_FF_DELAY	1	Feed-forward delay for anti-clip feature 0 = 5 samples 1 = 9 samples Time delay can be calculated as $5/f_s$ or $9/f_s$ , where $f_s$ is the sample rate.
	1	DRC_ANTICLIP_ENA	1	Anti-clip enable 0 = disabled 1 = enabled

**Table 13 DRC Anti-Clip Control**

**QUICK RELEASE CONTROL**

The DRC includes a Quick-Release feature to handle short transient peaks that are not related to the intended source signal. For example, in handheld microphone recording, transient signal peaks sometimes occur due to user handling, key presses or accidental tapping against the microphone. The Quick Release feature ensures that these transients do not cause the intended signal to be masked by the longer time constants of DRC\_DECAY\_RATE.

The Quick-Release feature is enabled by setting the DRC\_QR\_ENA bit. When this bit is enabled, the DRC measures the crest factor (peak to RMS ratio) of the input signal. A high crest factor is indicative of a transient peak that may not be related to the intended source signal. If the crest factor exceeds the level set by DRC\_THRESH\_QR, then the normal decay rate (DRC\_DECAY\_RATE) is ignored and a faster decay rate (DRC\_RATE\_QR) is used instead.

The DRC Quick-Release control bits are described in Table 14.

REGISTER ADDRESS	BIT	LABEL	DEFAULT	DESCRIPTION
R40 (28h) DRC 0	2	DRC_QR_ENA	1	Quick release enable 0 = disabled 1 = enabled
R41 (29h) DRC 1	7:6	DRC_THRESH_QR [1:0]	01	Quick release crest factor threshold 00 = 12dB 01 = 18dB (default) 10 = 24dB 11 = 30dB
	5:4	DRC_RATE_QR [1:0]	00	Quick release decay rate (seconds/6dB) 00 = 0.725ms (default) 01 = 1.45ms 10 = 5.8ms 11 = Reserved

Table 14 DRC Quick-Release Control

### GAIN SMOOTHING

The DRC includes a gain smoothing filter in order to prevent gain ripples. A programmable level of hysteresis is also used to control the DRC gain. This improves the handling of very low frequency input signals whose period is close to the DRC attack/decay time. DRC Gain Smoothing is enabled by default and it is recommended to use the default register settings.

The extent of the gain smoothing filter may be adjusted or disabled using the control fields described in Table 15.

REGISTER ADDRESS	BIT	LABEL	DEFAULT	DESCRIPTION
R40 (28h) DRC 0	12:11	DRC_THRESH_HYST [1:0]	01	Gain smoothing hysteresis threshold 00 = Low 01 = Medium (recommended) 10 = High 11 = Reserved
	3	DRC_SMOOTH_ENA	1	Gain smoothing enable 0 = disabled 1 = enabled
	0	DRC_HYST_ENA	1	Gain smoothing hysteresis enable 0 = disabled 1 = enabled

Table 15 DRC Gain Smoothing

**INITIALISATION**

When the DRC is initialised, the gain is set to the level determined by the DRC\_STARTUP\_GAIN register field. The default setting is 0dB, but values from -18dB to +36dB are available, as described in Table 16.

REGISTER ADDRESS	BIT	LABEL	DEFAULT	DESCRIPTION
R40 (28h) DRC 0	10:6	DRC_STARTUP_ GAIN [4:0]	00110	Initial gain at DRC startup 00000 = -18dB 00001 = -15dB 00010 = -12dB 00011 = -9dB 00100 = -6dB 00101 = -3dB 00110 = 0dB (default) 00111 = 3dB 01000 = 6dB 01001 = 9dB 01010 = 12dB 01011 = 15dB 01100 = 18dB 01101 = 21dB 01110 = 24dB 01111 = 27dB 10000 = 30dB 10001 = 33dB 10010 = 36dB 10011 to 11111 = Reserved

**Table 16 DRC Initialisation**

## DIGITAL MIXING

The Digital Microphone and DAC data can be combined in various ways to support a range of different usage modes.

Data from either of the two Digital Microphone channels can be routed to either the left or the right channel of the digital audio interface. In addition, data from either of the digital audio interface channels can be routed to either the left or the right DAC. See "Digital Audio Interface" for more information on the audio interface.

The WM8910 provides a Dynamic Range Control (DRC) feature, which can apply compression and gain adjustment in the digital microphone signal path. This is effective in controlling signal levels under conditions where input amplitude is unknown or varies over a wide range.

The DACs can be configured as a mono mix of the two audio channels. Digital sidetone from the Digital Microphones can also be selectively mixed into the DAC output path.

### DIGITAL MIXING PATHS

Figure 24 shows the digital mixing paths available in the WM8910 digital core.

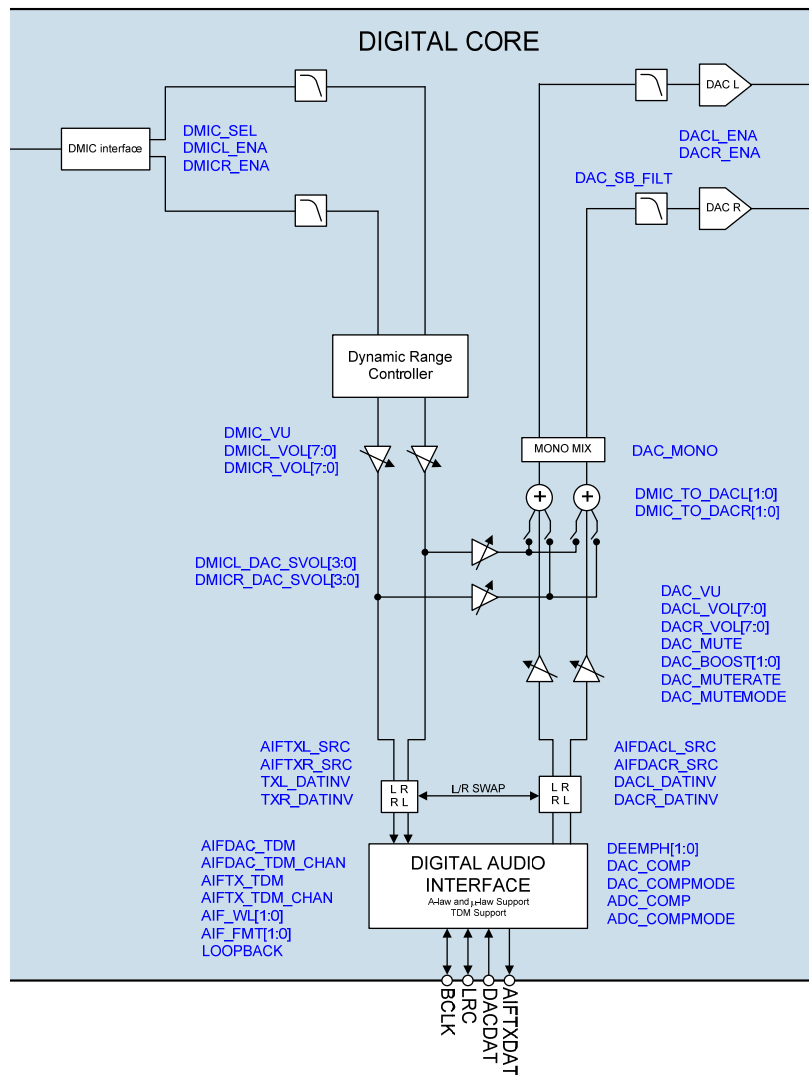

Figure 24 Digital Mixing Paths

The polarity of each Digital Microphone channel can be changed under software control using the TXL\_DATINV and TXR\_DATINV register bits. The AIFTXL\_SRC and AIFTXR\_SRC register bits may be used to select which Digital Microphone channel is used for the left and right digital audio interface data. These register bits are described in Table 17.

REGISTER ADDRESS	BIT	LABEL	DEFAULT	DESCRIPTION
R24 (18h) Audio Interface 0	7	AIFTXL_SRC	0	Left Digital Audio channel source 0 = Left DMIC data is output on left channel 1 = Right DMIC data is output on left channel
	6	AIFTXR_SRC	1	Right Digital Audio channel source 0 = Left DMIC data is output on right channel 1 = Right DMIC data is output on right channel
R38 (26h) DMIC Digital 0	1	TXL_DATINV	0	Left Digital Microphone Invert 0 = Left DMIC output not inverted 1 = Left DMIC output inverted
	0	TXR_DATINV	0	Right Digital Microphone Invert 0 = Right DMIC output not inverted 1 = Right DMIC output inverted

Table 17 DMIC Routing and Control

The input data source for each DAC can be changed under software control using register bits DACL\_SRC and DACR\_SRC. The polarity of each DAC input may also be modified using register bits DACL\_DATINV and DACR\_DATINV. These register bits are described in Table 18.

REGISTER ADDRESS	BIT	LABEL	DEFAULT	DESCRIPTION
R24 (18h) Audio Interface 0	12	DACL_DATINV	0	Left DAC Invert 0 = Left DAC output not inverted 1 = Left DAC output inverted
	11	DACR_DATINV	0	Right DAC Invert 0 = Right DAC output not inverted 1 = Right DAC output inverted
	5	AIFDACL_SRC	0	Left DAC Data Source Select 0 = Left DAC outputs left channel data 1 = Left DAC outputs right channel data
	4	AIFDACR_SRC	1	Right DAC Data Source Select 0 = Right DAC outputs left channel data 1 = Right DAC outputs right channel data

Table 18 DAC Routing and Control

#### DAC INTERFACE VOLUME BOOST

A digital gain function is available at the audio interface to boost the DAC volume when a small signal is received on DACDAT. This is controlled using register bits DAC\_BOOST [1:0]. To prevent clipping at the DAC input, this function should not be used when the boosted DAC data is expected to be greater than 0dBFS.

The digital interface volume is controlled as shown in Table 19.

REGISTER ADDRESS	BIT	LABEL	DEFAULT	DESCRIPTION
R24 (18h) Audio Interface 0	10:9	DAC_BOOST [1:0]	00	DAC Input Volume Boost 00 = 0dB 01 = +6dB (Input data must not exceed -6dBFS) 10 = +12dB (Input data must not exceed -12dBFS) 11 = +18dB (Input data must not exceed -18dBFS)

**Table 19 DAC Interface Volume Boost**

### DIGITAL SIDETONE

Digital sidetone mixing (from Digital Microphone output into DAC input) is available when Digital Microphones and DACs are operating at the same sample rate. Digital data from either left or right DMIC can be mixed with the audio interface data on the left and right DAC channels.

When using the digital sidetone, it is recommended that the Digital Microphones are enabled before un-muting the DACs to prevent pop noise. The DAC volumes and sidetone volumes should be set to an appropriate level to avoid clipping at the DAC input.

When digital sidetone is used, it is recommended that the Charge Pump operates in Register Control mode only (CP\_DYN\_PWR = 0). See "Charge Pump" for details.

The digital sidetone is controlled as shown in Table 20.

REGISTER ADDRESS	BIT	LABEL	DEFAULT	DESCRIPTION
R32 (20h) DAC Digital 0	11:8	DMICL_DAC_S VOL [3:0]	0000	Left Digital Sidetone Volume 0000 = -36dB 0001 = -33dB (... 3dB steps) 1011 = -3dB 11XX = 0dB (See Table 21 for volume range)
	7:4	DMICR_DAC_S VOL [3:0]	0000	Right Digital Sidetone Volume 0000 = -36dB 0001 = -33dB (... 3dB steps) 1011 = -3dB 11XX = 0dB (See Table 21 for volume range)
	3:2	DMIC_TO_DAC L [1:0]	00	Left DAC Digital Sidetone Source 00 = No sidetone 01 = Left Digital Microphone 10 = Right Digital Microphone 11 = Reserved
	1:0	DMIC_TO_DAC R [1:0]	00	Right DAC Digital Sidetone Source 00 = No sidetone 01 = Left Digital Microphone 10 = Right Digital Microphone 11 = Reserved

**Table 20 Digital Sidetone Control**

The digital sidetone volume settings are shown in Table 21.

DMICL_DAC_SVOL OR DMICR_DAC_SVOL	SIDETONE VOLUME
0000	-36
0001	-33
0010	-30
0011	-27
0100	-24
0101	-21
0110	-18
0111	-15
1000	-12
1001	-9
1010	-6
1011	-3
1100	0
1101	0
1110	0
1111	0

Table 21 Digital Sidetone Volume

## DIGITAL-TO-ANALOGUE CONVERTER (DAC)

The WM8910 DACs receive digital input data from the DACDAT pin and via the digital sidetone path (see "Digital Mixing" section). The digital audio data is converted to oversampled bit streams in the on-chip, true 24-bit digital interpolation filters. The bitstream data enters two multi-bit, sigma-delta DACs, which convert them to high quality analogue audio signals. The Wolfson SmartDAC™ architecture offers reduced power consumption, whilst also delivering a reduction in high frequency noise and sensitivity to clock jitter. It also uses a Dynamic Element Matching technique for high linearity and low distortion.

The analogue outputs from the DACs can then be mixed with other analogue inputs before being sent to the analogue output pins (see "Output Signal Path").

The DACs are enabled by the DACL\_ENA and DACR\_ENA register bits.

REGISTER ADDRESS	BIT	LABEL	DEFAULT	DESCRIPTION
R18 (12h) Power Management 6	3	DACL_ENA	0	Left DAC Enable 0 = DAC disabled 1 = DAC enabled
	2	DACR_ENA	0	Right DAC Enable 0 = DAC disabled 1 = DAC enabled

Table 22 DAC Enable Control

### DAC DIGITAL VOLUME CONTROL

The output level of each DAC can be controlled digitally over a range from -71.625dB to 0dB in 0.375dB steps. The level of attenuation for an eight-bit code is detailed in Table 24.

The DAC\_VU bit controls the loading of digital volume control data. When DAC\_VU is set to 0, the DACL\_VOL or DACR\_VOL control data is loaded into the respective control register, but does not actually change the digital gain setting. Both left and right gain settings are updated when a 1 is written to DAC\_VU. This makes it possible to update the gain of both channels simultaneously.

REGISTER ADDRESS	BIT	LABEL	DEFAULT	DESCRIPTION
R30 (1Eh) DAC Digital Volume Left	8	DACVU	N/A	DAC Volume Update Writing a 1 to this bit causes left and right DAC volume to be updated simultaneously (Write-Only Register)
	7:0	DACL_VOL [7:0]	1100_0000 (0dB)	Left DAC Digital Volume 00h = Mute 01h = -71.625dB 02h = -71.250dB ... (0.375dB steps) C0h = 0dB ... (0.375dB steps) EFh to FFh = +17.625dB (See Table 24 for volume range)
R31 (1Fh) DAC Digital Volume Right	8	DACVU	N/A	DAC Volume Update Writing a 1 to this bit causes left and right DAC volume to be updated simultaneously (Write-Only Register)
	7:0	DACR_VOL [7:0]	1100_0000 (0dB)	Right DAC Digital Volume 00h = Mute 01h = -71.625dB 02h = -71.250dB ... (0.375dB steps) C0h = 0dB ... (0.375dB steps) EFh to FFh = +17.625dB (See Table 24 for volume range)

Table 23 DAC Digital Volume Control

DACL_VOL or DACR_VOL    Volume (dB)		DACL_VOL or DACR_VOL    Volume (dB)		DACL_VOL or DACR_VOL    Volume (dB)		DACL_VOL or DACR_VOL    Volume (dB)	
0h	MUTE	40h	-48.000	80h	-24.000	C0h	0.000
1h	-71.625	41h	-47.625	81h	-23.625	C1h	0.000
2h	-71.250	42h	-47.250	82h	-23.250	C2h	0.000
3h	-70.875	43h	-46.875	83h	-22.875	C3h	0.000
4h	-70.500	44h	-46.500	84h	-22.500	C4h	0.000
5h	-70.125	45h	-46.125	85h	-22.125	C5h	0.000
6h	-69.750	46h	-45.750	86h	-21.750	C6h	0.000
7h	-69.375	47h	-45.375	87h	-21.375	C7h	0.000
8h	-69.000	48h	-45.000	88h	-21.000	C8h	0.000
9h	-68.625	49h	-44.625	89h	-20.625	C9h	0.000
Ah	-68.250	4Ah	-44.250	8Ah	-20.250	CAh	0.000
Bh	-67.875	4Bh	-43.875	8Bh	-19.875	CBh	0.000
Ch	-67.500	4Ch	-43.500	8Ch	-19.500	CCh	0.000
Dh	-67.125	4Dh	-43.125	8Dh	-19.125	CDh	0.000
Eh	-66.750	4Eh	-42.750	8Eh	-18.750	CEh	0.000
Fh	-66.375	4Fh	-42.375	8Fh	-18.375	CFh	0.000
10h	-66.000	50h	-42.000	90h	-18.000	D0h	0.000
11h	-65.625	51h	-41.625	91h	-17.625	D1h	0.000
12h	-65.250	52h	-41.250	92h	-17.250	D2h	0.000
13h	-64.875	53h	-40.875	93h	-16.875	D3h	0.000
14h	-64.500	54h	-40.500	94h	-16.500	D4h	0.000
15h	-64.125	55h	-40.125	95h	-16.125	D5h	0.000
16h	-63.750	56h	-39.750	96h	-15.750	D6h	0.000
17h	-63.375	57h	-39.375	97h	-15.375	D7h	0.000
18h	-63.000	58h	-39.000	98h	-15.000	D8h	0.000
19h	-62.625	59h	-38.625	99h	-14.625	D9h	0.000
1Ah	-62.250	5Ah	-38.250	9Ah	-14.250	DAh	0.000
1Bh	-61.875	5Bh	-37.875	9Bh	-13.875	DBh	0.000
1Ch	-61.500	5Ch	-37.500	9Ch	-13.500	DCh	0.000
1Dh	-61.125	5Dh	-37.125	9Dh	-13.125	DDh	0.000
1Eh	-60.750	5Eh	-36.750	9Eh	-12.750	DEh	0.000
1Fh	-60.375	5Fh	-36.375	9Fh	-12.375	DFh	0.000
20h	-60.000	60h	-36.000	A0h	-12.000	E0h	0.000
21h	-59.625	61h	-35.625	A1h	-11.625	E1h	0.000
22h	-59.250	62h	-35.250	A2h	-11.250	E2h	0.000
23h	-58.875	63h	-34.875	A3h	-10.875	E3h	0.000
24h	-58.500	64h	-34.500	A4h	-10.500	E4h	0.000
25h	-58.125	65h	-34.125	A5h	-10.125	E5h	0.000
26h	-57.750	66h	-33.750	A6h	-9.750	E6h	0.000
27h	-57.375	67h	-33.375	A7h	-9.375	E7h	0.000
28h	-57.000	68h	-33.000	A8h	-9.000	E8h	0.000
29h	-56.625	69h	-32.625	A9h	-8.625	E9h	0.000
2Ah	-56.250	6Ah	-32.250	AAh	-8.250	EAh	0.000
2Bh	-55.875	6Bh	-31.875	ABh	-7.875	EBh	0.000
2Ch	-55.500	6Ch	-31.500	ACH	-7.500	ECh	0.000
2Dh	-55.125	6Dh	-31.125	ADh	-7.125	EDh	0.000
2Eh	-54.750	6Eh	-30.750	A Eh	-6.750	EEh	0.000
2Fh	-54.375	6Fh	-30.375	AFh	-6.375	EFh	0.000
30h	-54.000	70h	-30.000	B0h	-6.000	F0h	0.000
31h	-53.625	71h	-29.625	B1h	-5.625	F1h	0.000
32h	-53.250	72h	-29.250	B2h	-5.250	F2h	0.000
33h	-52.875	73h	-28.875	B3h	-4.875	F3h	0.000
34h	-52.500	74h	-28.500	B4h	-4.500	F4h	0.000
35h	-52.125	75h	-28.125	B5h	-4.125	F5h	0.000
36h	-51.750	76h	-27.750	B6h	-3.750	F6h	0.000
37h	-51.375	77h	-27.375	B7h	-3.375	F7h	0.000
38h	-51.000	78h	-27.000	B8h	-3.000	F8h	0.000
39h	-50.625	79h	-26.625	B9h	-2.625	F9h	0.000
3Ah	-50.250	7Ah	-26.250	BAh	-2.250	FAh	0.000
3Bh	-49.875	7Bh	-25.875	BBh	-1.875	FBh	0.000
3Ch	-49.500	7Ch	-25.500	BCh	-1.500	FCh	0.000
3Dh	-49.125	7Dh	-25.125	BDh	-1.125	FDh	0.000
3Eh	-48.750	7Eh	-24.750	BEh	-0.750	FEh	0.000
3Fh	-48.375	7Fh	-24.375	BFh	-0.375	FFh	0.000

Table 24 DAC Digital Volume Range

**DAC SOFT MUTE AND SOFT UN-MUTE**

The WM8910 has a soft mute function. When enabled, this gradually attenuates the volume of the DAC output. When soft mute is disabled, the gain will either gradually ramp back up to the digital gain setting, or return instantly to the digital gain setting, depending on the DAC\_MUTEMODE register bit.

The DAC is not muted by default (DAC\_MUTE = 0). To mute the DAC, this function must be enabled by setting DAC\_MUTE to 1.

Soft Mute Mode would typically be enabled (DAC\_MUTEMODE = 1) when using DAC\_MUTE during playback of audio data so that when DAC\_MUTE is subsequently disabled, the sudden volume increase will not create pop noise by jumping immediately to the previous volume level (e.g. resuming playback after pausing during a track).

Soft Mute Mode would typically be disabled (DAC\_MUTEMODE = 0) when un-muting at the start of a music file, in order that the first part of the track is not attenuated (e.g. when starting playback of a new track, or resuming playback after pausing between tracks).

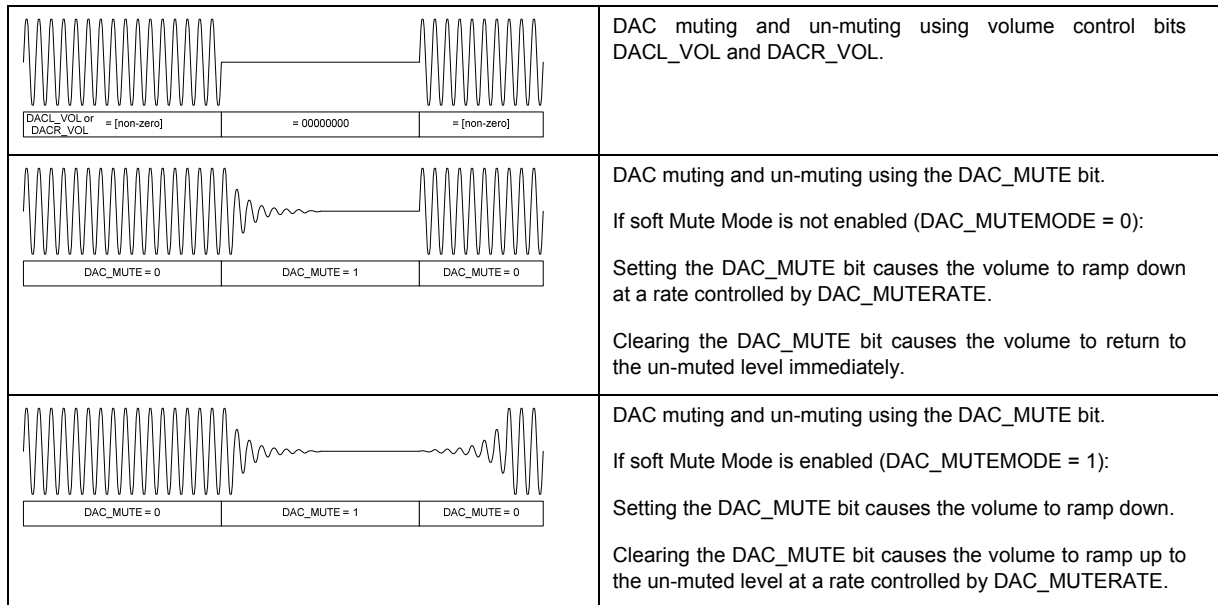

Figure 25 DAC Mute Control

The volume ramp rate during soft mute and un-mute is controlled by the DAC\_MUTERATE bit. Ramp rates of  $fs/32$  and  $fs/2$  can be selected, as shown in Table 25. The ramp rate determines the rate at which the volume is increased or decreased. The actual ramp time depends on the extent of the difference between the muted and un-muted volume settings.

REGISTER ADDRESS	BIT	LABEL	DEFAULT	DESCRIPTION
R33 (21h) DAC Digital 1	10	DAC_MUTERATE	0	DAC Soft Mute Ramp Rate 0 = Fast ramp ( $fs/2$ , maximum ramp time is 10.7ms at $fs=48k$ ) 1 = Slow ramp ( $fs/32$ , maximum ramp time is 171ms at $fs=48k$ )
	9	DAC_MUTEMODE	0	DAC Soft Mute Mode 0 = Disabling soft-mute (DAC_MUTE=0) will cause the DAC volume to change immediately to DACL_VOL and DACR_VOL settings 1 = Disabling soft-mute (DAC_MUTE=0) will cause the DAC volume to ramp up gradually to the DACL_VOL and DACR_VOL settings
	3	DAC_MUTE	0	DAC Soft Mute Control 0 = DAC Un-mute 1 = DAC Mute

Table 25 DAC Soft-Mute Control

### DAC MONO MIX

A DAC digital mono-mix mode can be enabled using the DAC\_MONO register bit. This mono mix will be output on whichever DAC is enabled. To prevent clipping, a -6dB attenuation is automatically applied to the mono mix.

The mono mix is only supported when one or other DAC is disabled. When the mono mix is selected, then the mono mix is output on the enabled DAC only; there is no output from the disabled DAC. If DAC\_ENA and DACR\_ENA are both set, then stereo operation applies.

REGISTER ADDRESS	BIT	LABEL	DEFAULT	DESCRIPTION
R33 (21h) DAC Digital 1	12	DAC_MONO	0	DAC Mono Mix 0 = Stereo 1 = Mono (Mono mix output on enabled DAC)

Table 26 DAC Mono Mix

### DAC DE-EMPHASIS

Digital de-emphasis can be applied to the DAC playback data (e.g. when the data comes from a CD with pre-emphasis used in the recording). De-emphasis filtering is available for sample rates of 48kHz, 44.1kHz and 32kHz. See "Digital Filter Characteristics" for details of de-emphasis filter characteristics.

REGISTER ADDRESS	BIT	LABEL	DEFAULT	DESCRIPTION
R33 (21h) DAC Digital 1	2:1	DEEMPH [1:0]	00	DAC De-Emphasis Control 00 = No de-emphasis 01 = 32kHz sample rate 10 = 44.1kHz sample rate 11 = 48kHz sample rate

Table 27 DAC De-Emphasis Control

### DAC SLOPING STOPBAND FILTER

Two DAC filter types are available, selected by the register bit DAC\_SB\_FILT. When operating at sample rates  $\leq 24\text{kHz}$  (e.g. during voice communication) it is recommended that the sloping stopband filter type is selected (DAC\_SB\_FILT=1) to reduce out-of-band noise which can be audible at low DAC sample rates. See "Digital Filter Characteristics" for details of DAC filter characteristics.

REGISTER ADDRESS	BIT	LABEL	DEFAULT	DESCRIPTION
R33 (21h) DAC Digital 1	11	DAC_SB_FILT	0	Selects DAC filter characteristics 0 = Normal mode 1 = Sloping stopband mode (recommended when $f_s \leq 24\text{kHz}$ )

Table 28 DAC Sloping Stopband Filter

### DAC BIAS CONTROL

The analogue circuits within the DAC use the Master bias current (see "Reference Voltages and Master Bias"). The DAC bias currents can also be reduced using the DACBIAS\_SEL and DACVMID\_SEL fields as described in Table 29. These can be used to reduce power consumption, but may have a marginal impact on audio performance in some usage modes.

The DAC bias currents can be increased using the DAC\_BIAS\_BOOST field. Setting this bit doubles the bias level of DACBIAS\_SEL and DACVMID\_BIAS\_SEL. This offers a performance improvement, but also an increase in power consumption.

Note that the increased DAC VMID buffer bias is unlikely to give better performance; when DAC\_BIAS\_BOOST is set, it is recommended to set DACVMID\_BIAS\_SEL = 01 in order to restore the Normal DAC VMID buffer bias level.

REGISTER ADDRESS	BIT	LABEL	DEFAULT	DESCRIPTION
R8 (08h) Analogue DAC 0	5	DAC_BIAS_BOOST	0	DAC Bias boost 0 = Disable 1 = Enable  When DAC Bias boost is enabled, the bias selected by DACBIAS_SEL and DACVMID_BIAS_SEL are both doubled.
	4:3	DACBIAS_SEL	00	DAC bias current select 00 = Normal bias 01 = Normal bias x 0.5 10 = Normal bias x 0.66 11 = Normal bias x 0.75
	2:1	DACVMID_BIAS_SEL	00	DAC VMID buffer bias select 00 = Normal bias 01 = Normal bias x 0.5 10 = Normal bias x 0.66 11 = Normal bias x 0.75

Table 29 DAC Bias Control

**DAC OVERSAMPLING RATIO (OSR)**

The DAC oversampling rate is programmable to allow power consumption versus audio performance trade-offs. The default oversampling rate is low for reduced power consumption; using the higher OSR setting improves the DAC signal-to-noise performance.

REGISTER ADDRESS	BIT	LABEL	DEFAULT	DESCRIPTION
R33 (21h) DAC Digital 1	0	DAC_OSR	0	DAC Oversampling Control 0 = Low power (normal oversample) 1 = High performance (double rate)

**Table 30 DAC Oversampling Control**

## OUTPUT SIGNAL PATH

The outputs HPOUTL and LINEOUTL are derived from the Left Mixer, whilst the HPOUTR and LINEOUTR are derived from the Right Mixer. These mixers allow the stereo DAC and stereo bypass (analogue input) signals to be mixed together for the Headphone and Line outputs.

A feedback path for common mode noise rejection is provided at HPOUTFB and LINEOUTFB for the Headphone and Line outputs respectively. This pin must be connected to ground for normal operation.

The outputs LOP/LON and ROP/RON are differential line outputs derived from the Left Speaker mixer and Right Speaker mixer respectively.

Each analogue output can be separately enabled; independent volume control is also provided for each output. The output signal paths and associated control registers are illustrated in Figure 26. See "Analogue Outputs" for details of the external connections to these outputs.

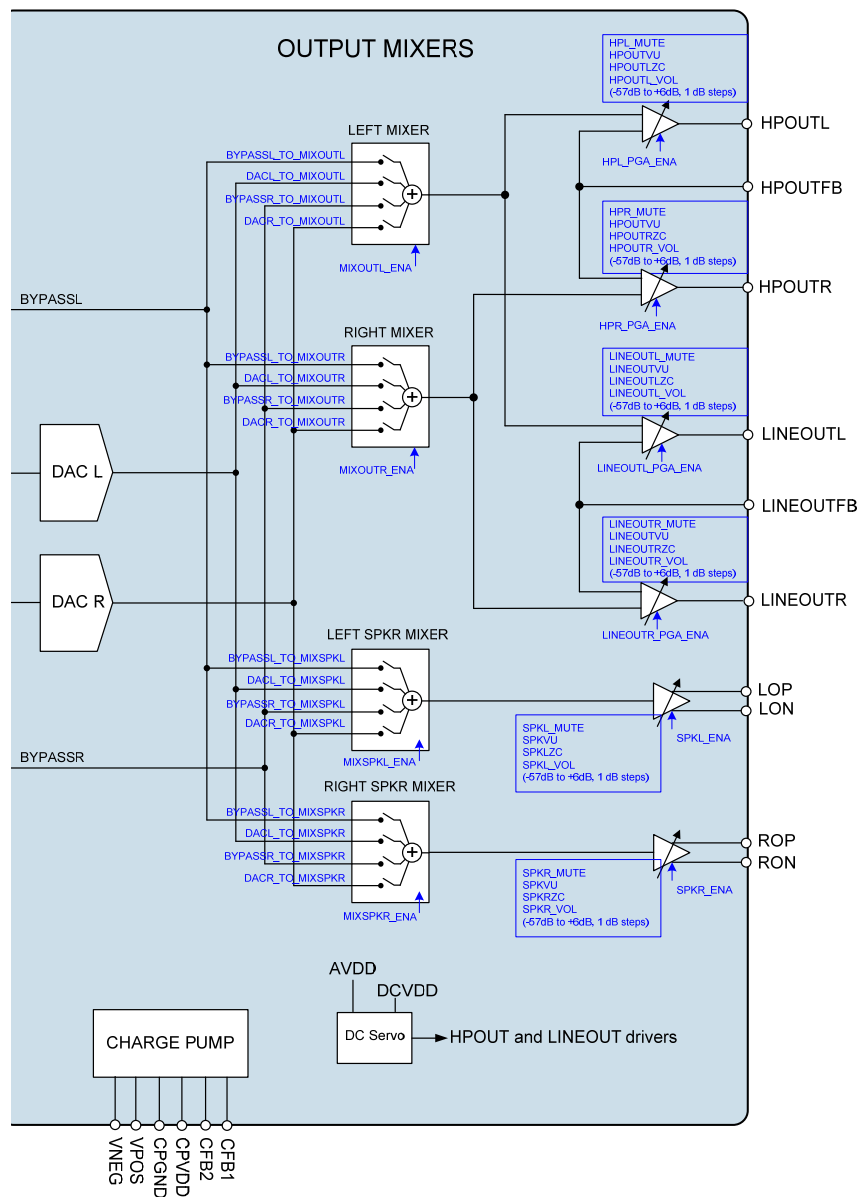

Figure 26 Output Signal Path and Control Registers

### OUTPUT SIGNAL PATHS ENABLE

The output mixers and drivers can be independently enabled and disabled using the register bits described in Table 31.

Note that the Headphone Outputs and Line Outputs are also controlled by fields located within Register R90 and R94, which provide suppression of pops & clicks when enabling and disabling these signal paths. These registers are described in the following “Headphone / Line Output Signal Paths Enable” section.

Under recommended usage conditions, the pop suppression control bits will be configured by scheduling the default Start-Up and Shut-Down sequences as described in the “Control Write Sequencer” section. In these cases, the user does not need to set the register fields in R13, R14, R15, R90 and R94 directly.

REGISTER ADDRESS	BIT	LABEL	DEFAULT	DESCRIPTION
R13 (0Dh) Power Management 1	1	MIXOUTL_ENA	0	Left Output Mixer Enable 0 = disabled 1 = enabled
	0	MIXOUTR_ENA	0	Right Output Mixer Enable 0 = disabled 1 = enabled
R14 (0Eh) Power Management 2	1	HPL_PGA_ENA	0	Left Headphone Output Enable 0 = disabled 1 = enabled
	0	HPR_PGA_ENA	0	Right Headphone Output Enable 0 = disabled 1 = enabled
R15 (0Fh) Power Management 3	1	LINEOUTL_PGA_ENA	0	Left Line Output Enable 0 = disabled 1 = enabled
	0	LINEOUTR_PGA_ENA	0	Right Line Output Enable 0 = disabled 1 = enabled
R16 (10h) Power Management 4	1	MIXSPKL_ENA	0	Left Speaker Mixer Enable 0 = disabled 1 = enabled
	0	MIXSPKR_ENA	0	Right Speaker Mixer Enable 0 = disabled 1 = enabled
R17 (11h) Power Management 5	1	SPKL_ENA	0	Left Speaker Output Enable 0 = disabled 1 = enabled
	0	SPKR_ENA	0	Right Speaker Output Enable 0 = disabled 1 = enabled

**Table 31 Output Signal Paths Enable**

To enable the output PGAs and mixers, the reference voltage VMID and the bias current must also be enabled. See “Reference Voltages and Master Bias” for details of the associated controls VMID\_RES and BIAS\_ENA.

**HEADPHONE / LINE OUTPUT SIGNAL PATHS ENABLE**

The Headphone / Line output paths can be actively discharged to AGND through internal resistors if desired. This is desirable at start-up in order to achieve a known output stage condition prior to enabling the VMID reference voltage. This is also desirable in shutdown to prevent the external connections from being affected by the internal circuits. The ground-referenced Headphone outputs and Line outputs are shorted to AGND by default; the short circuit is removed on each of these paths by setting the applicable fields HPL\_RMV\_SHORT, HPR\_RMV\_SHORT, LINEOUTL\_RMV\_SHORT or LINEOUTR\_RMV\_SHORT.

The ground-referenced Headphone output and Line output drivers are designed to suppress pops and clicks when enabled or disabled. However, it is necessary to control the drivers in accordance with a defined sequence in start-up and shut-down to achieve the pop suppression. It is also necessary to schedule the DC Servo offset correction at the appropriate point in the sequence (see "DC Servo"). Table 32 and Table 33 describe the recommended sequences for enabling and disabling these output drivers.

SEQUENCE	HEADPHONE ENABLE	LINEOUT ENABLE
Step 1	HPL_ENA = 1 HPR_ENA = 1	LINEOUTL_ENA = 1 LINEOUTR_ENA = 1
Step 2	HPL_ENA_DLY = 1 HPR_ENA_DLY = 1	LINEOUTL_ENA_DLY = 1 LINEOUTR_ENA_DLY = 1
Step 3	DC offset correction	DC offset correction
Step 4	HPL_ENA_OUTP = 1 HPR_ENA_OUTP = 1	LINEOUTL_ENA_OUTP = 1 LINEOUTR_ENA_OUTP = 1
Step 5	HPL_RMV_SHORT = 1 HPR_RMV_SHORT = 1	LINEOUTL_RMV_SHORT = 1 LINEOUTR_RMV_SHORT = 1

**Table 32 Headphone / Line Output Enable Sequence**

SEQUENCE	HEADPHONE DISABLE	LINEOUT DISABLE
Step 1	HPL_RMV_SHORT = 0 HPR_RMV_SHORT = 0	LINEOUTL_RMV_SHORT = 0 LINEOUTR_RMV_SHORT = 0
Step 2	HPL_ENA = 0 HPL_ENA_DLY = 0 HPL_ENA_OUTP = 0 HPR_ENA = 0 HPR_ENA_DLY = 0 HPR_ENA_OUTP = 0	LINEOUTL_ENA = 0 LINEOUTL_ENA_DLY = 0 LINEOUTL_ENA_OUTP = 0 LINEOUTR_ENA = 0 LINEOUTR_ENA_DLY = 0 LINEOUTR_ENA_OUTP = 0

**Table 33 Headphone / Line Output Disable Sequence**

The registers relating to Headphone / Line Output pop suppression control are defined in Table 34.

REGISTER ADDRESS	BIT	LABEL	DEFAULT	DESCRIPTION
R90 (5Ah) Analogue HP 0	7	HPL_RMV_SHORT	0	Removes HPL short 0 = HPL short enabled 1 = HPL short removed For normal operation, this bit should be set as the final step of the HPL Enable sequence.
	6	HPL_ENA_OUTP	0	Enables HPL output stage 0 = Disabled 1 = Enabled For normal operation, this bit should be set to 1 after the DC offset cancellation has been scheduled.

REGISTER ADDRESS	BIT	LABEL	DEFAULT	DESCRIPTION
	5	HPL_ENA_DLY	0	Enables HPL intermediate stage 0 = Disabled 1 = Enabled For normal operation, this bit should be set to 1 after the output signal path has been configured, and before DC offset cancellation is scheduled. This bit should be set with at least 20us delay after HPL_ENA.
	4	HPL_ENA	0	Enables HPL input stage 0 = Disabled 1 = Enabled For normal operation, this bit should be set as the first step of the HPL Enable sequence.
	3	HPR_RMV_SHORT	0	Removes HPR short 0 = HPR short enabled 1 = HPR short removed For normal operation, this bit should be set as the final step of the HPR Enable sequence.
	2	HPR_ENA_OUTP	0	Enables HPR output stage 0 = Disabled 1 = Enabled For normal operation, this bit should be set to 1 after the DC offset cancellation has been scheduled.
	1	HPR_ENA_DLY	0	Enables HPR intermediate stage 0 = Disabled 1 = Enabled For normal operation, this bit should be set to 1 after the output signal path has been configured, and before DC offset cancellation is scheduled. This bit should be set with at least 20us delay after HPR_ENA.
	0	HPR_ENA	0	Enables HPR input stage 0 = Disabled 1 = Enabled For normal operation, this bit should be set as the first step of the HPR Enable sequence.
	R94 (5Eh) Analogue Lineout 0	7	LINEOUTL_RMV_SHORT	0

REGISTER ADDRESS	BIT	LABEL	DEFAULT	DESCRIPTION
	6	LINEOUTL_ENA_OUTP	0	Enables LINEOUTL output stage 0 = Disabled 1 = Enabled For normal operation, this bit should be set to 1 after the DC offset cancellation has been scheduled.
	5	LINEOUTL_ENA_DLY	0	Enables LINEOUTL intermediate stage 0 = Disabled 1 = Enabled For normal operation, this bit should be set to 1 after the output signal path has been configured, and before DC offset cancellation is scheduled. This bit should be set with at least 20us delay after LINEOUTL_ENA.
	4	LINEOUTL_ENA	0	Enables LINEOUTL input stage 0 = Disabled 1 = Enabled For normal operation, this bit should be set as the first step of the LINEOUTL Enable sequence.
	3	LINEOUTR_RMV_SHORT	0	Removes LINEOUTR short 0 = LINEOUTR short enabled 1 = LINEOUTR short removed For normal operation, this bit should be set as the final step of the LINEOUTR Enable sequence.
	2	LINEOUTR_ENA_OUTP	0	Enables LINEOUTR output stage 0 = Disabled 1 = Enabled For normal operation, this bit should be set to 1 after the DC offset cancellation has been scheduled.
	1	LINEOUTR_ENA_DLY	0	Enables LINEOUTR intermediate stage 0 = Disabled 1 = Enabled For normal operation, this bit should be set to 1 after the output signal path has been configured, and before DC offset cancellation is scheduled. This bit should be set with at least 20us delay after LINEOUTR_ENA.
	0	LINEOUTR_ENA	0	Enables LINEOUTR input stage 0 = Disabled 1 = Enabled For normal operation, this bit should be set as the first step of the LINEOUTR Enable sequence.

Table 34 Headphone / Line Output Pop Suppression Control

**OUTPUT PGA BIAS CONTROL**

The output PGA circuits use the Master bias current (see “Reference Voltages and Master Bias”). The output PGA bias currents can also be controlled using the PGA\_BIAS field as described in Table 35. Selecting a lower bias can be used to reduce power consumption, but may have a marginal impact on audio performance in some usage modes. Selecting a higher bias offers a performance improvement, but also an increase in power consumption.

REGISTER ADDRESS	BIT	LABEL	DEFAULT	DESCRIPTION
R172 (ACh) Analogue Output Bias 0	6:4	PGA_BIAS [2:0]	000	Headphone and Lineout PGA bias control 000 = Normal bias 001 = Normal bias x 1.5 010 = Normal bias x 0.75 011 = Normal bias x 0.5 100 = Normal bias x 0.33 101 = Normal bias 110 = Normal bias 111 = Normal bias x 2

Table 35 Output PGA Bias Control

**OUTPUT DRIVERS BIAS CONTROL**

The bias of the Headphone and Lineout drivers can be controlled independently of the PGA bias. These may be increased or decreased using the OUTPUTS\_BIAS field as described in Table 36. This can be used to reduce power consumption or improve performance.

If it is desired to improve the performance of the outputs with the minimum increase in power consumption, then it is recommended to increase the OUTPUTS\_BIAS level and to use the default setting of PGA\_BIAS.

REGISTER ADDRESS	BIT	LABEL	DEFAULT	DESCRIPTION
R187 (BBh) Analogue Output Bias 2	2:0	OUTPUTS_BIAS [2:0]	000	Headphone and Lineout Output Drivers bias control 000 = Normal bias 001 = Normal bias x 1.5 010 = Normal bias x 0.75 011 = Normal bias x 0.5 100 = Normal bias x 0.33 101 = Normal bias 110 = Normal bias 111 = Normal bias x 2

Table 36 Output Drivers Bias Control

**OUTPUT MIXER CONTROL**

Each of the four output mixers has the same four inputs:

- DAC Left
- DAC Right
- Bypass Left (Analogue input)
- Bypass Right (Analogue input)

The input signals to the left and right mixers (feeding HPOUTL/R and LINEOUTL/R) are enabled using the register fields described in Table 37. These mixers do not provide volume controls on the inputs or outputs. However, input signals can be attenuated at source using the control fields LIN\_VOL, RIN\_VOL, DACL\_VOL and DACR\_VOL.

REGISTER ADDRESS	BIT	LABEL	DEFAULT	DESCRIPTION
R50 (32h) Analogue Left Mix 0	3	DACL_TO_MIXO UTL	1	Left DAC to Left Output Mixer Enable 0 = disabled 1 = enabled
	2	DACR_TO_MIXO UTL	0	Right DAC to Left Output Mixer Enable 0 = disabled 1 = enabled
	1	BYPASSL_TO_MI XOUTL	0	Left Analogue Input to Left Output Mixer Enable 0 = disabled 1 = enabled
	0	BYPASSR_TO_M IXOUTL	0	Right Analogue Input to Left Output Mixer Enable 0 = disabled 1 = enabled
R51 (33h) Analogue Right Mix 0	3	DACL_TO_MIXO UTR	0	Left DAC to Right Output Mixer Enable 0 = disabled 1 = enabled
	2	DACR_TO_MIXO UTR	1	Right DAC to Right Output Mixer Enable 0 = disabled 1 = enabled
	1	BYPASSL_TO_MI XOUTR	0	Left Analogue Input to Right Output Mixer Enable 0 = disabled 1 = enabled
	0	BYPASSR_TO_M IXOUTR	0	Right Analogue Input to Right Output Mixer Enable 0 = disabled 1 = enabled

**Table 37 Headphone and Line Output Mixer Control**

The input signals to the speaker mixers are enabled and controlled using the register fields described in Table 38.

These mixers provide a selectable 0dB or -6dB volume control on each input. The input signals may also be controlled at source using the control fields LIN\_VOL, RIN\_VOL, DACL\_VOL and DACR\_VOL, but it should be noted that adjusting these fields would also affect the other output mixers.

REGISTER ADDRESS	BIT	LABEL	DEFAULT	DESCRIPTION
R52 (34h) Analogue Spk Mix Left 0	3	DACL_TO_MIXSPKL	0	Left DAC to Left Spkr Mixer Enable 0 = disabled 1 = enabled
	2	DACR_TO_MIXSPKL	0	Right DAC to Left Spkr Mixer Enable 0 = disabled 1 = enabled
	1	BYPASSL_TO_MIXSPKL	0	Left Analogue Input to Left Spkr Mixer Enable 0 = disabled 1 = enabled
	0	BYPASSR_TO_MIXSPKL	0	Right Analogue Input to Left Spkr Mixer Enable 0 = disabled 1 = enabled
R53 (35h) Analogue Spk Mix Left 1	3	DACL_MIXSPKL_VOL	0	Left DAC to Left Spkr Mixer volume control 0 = 0dB 1 = -6dB
	2	DACR_MIXSPKL_VOL	0	Right DAC to Left Spkr Mixer volume control 0 = 0dB 1 = -6dB
	1	BYPASSL_MIXSPKL_VOL	0	Left Analogue Input to Left Spkr Mixer volume control 0 = 0dB 1 = -6dB
	0	BYPASSR_MIXSPKL_VOL	0	Right Analogue Input to Left Spkr Mixer volume control 0 = 0dB 1 = -6dB
R54 (36h) Analogue Spk Mix Right 0	3	DACL_TO_MIXSPKR	0	Left DAC to Right Spkr Mixer Enable 0 = disabled 1 = enabled
	2	DACR_TO_MIXSPKR	0	Right DAC to Right Spkr Mixer Enable 0 = disabled 1 = enabled
	1	BYPASSL_TO_MIXSPKR	0	Left Analogue Input to Right Spkr Mixer Enable 0 = disabled 1 = enabled
	0	BYPASSR_TO_MIXSPKR	0	Right Analogue Input to Right Spkr Mixer Enable 0 = disabled 1 = enabled

REGISTER ADDRESS	BIT	LABEL	DEFAULT	DESCRIPTION
R55 (37h) Analogue Spk Mix Right 1	3	DACL_MIXSPKR_VOL	0	Left DAC to Right Spkr Mixer volume control 0 = 0dB 1 = -6dB
	2	DACR_MIXSPKR_VOL	0	Right DAC to Right Spkr Mixer volume control 0 = 0dB 1 = -6dB
	1	BYPASSL_MIXSPKR_VOL	0	Left Analogue Input to Right Spkr Mixer volume control 0 = 0dB 1 = -6dB
	0	BYPASSR_MIXSPKR_VOL	0	Right Analogue Input to Right Spkr Mixer volume control 0 = 0dB 1 = -6dB

Table 38 Speaker Mixer Control

### OUTPUT VOLUME CONTROL

Each analogue output can be independently controlled. The headphone output control fields are described in Table 39. The line output control fields are described in Table 40. The differential line output control fields are described in Table 41. The output pins are described in more detail in "Analogue Outputs".

The volume and mute status of each output can be controlled individually using the bit fields shown in Table 39, Table 40 and Table 41.

To prevent "zipper noise" when a volume adjustment is made, a zero-cross function is provided on all output paths. When this function is enabled, volume updates will not take place until a zero-crossing is detected. In the event of a long period without zero-crossings, a timeout will apply. The timeout must be enabled by setting the TO\_ENA bit, as defined in "Clocking and Sample Rates".

The volume update bits control the loading of the output driver volume data. For example, when HPOUTVU is set to 0, the headphone volume data can be loaded into the respective control register, but will not actually change the gain setting. The Left and Right headphone volume settings are updated when a 1 is written to HPOUTVU. This makes it possible to update the gain of a Left/Right pair of output paths simultaneously.

REGISTER ADDRESS	BIT	LABEL	DEFAULT	DESCRIPTION
R57 (39h) Analogue OUT1 Left	8	HPL_MUTE	0	Left Headphone Output Mute 0 = Un-mute 1 = Mute
	7	HPOUTVU	0	Headphone Output Volume Update Writing a 1 to this bit will update HPOUTL and HPOUTR volumes simultaneously. (Write-Only Register)
	6	HPOUTLZC	0	Left Headphone Output Zero Cross Enable 0 = disabled 1 = enabled
	5:0	HPOUTL_VOL [5:0]	10_1101	Left Headphone Output Volume 000000 = -57dB 000001 = -56dB (... 1dB steps) 111001 = 0dB (... 1dB steps) 111110 = +5dB 111111 = +6dB
R58 (3Ah) Analogue OUT1 Right	8	HPR_MUTE	0	Right Headphone Output Mute 0 = Un-mute 1 = Mute
	7	HPOUTVU	0	Headphone Output Volume Update Writing a 1 to this bit will update HPOUTL and HPOUTR volumes simultaneously. (Write-Only Register)
	6	HPOUTRZC	0	Right Headphone Output Zero Cross Enable 0 = disabled 1 = enabled
	5:0	HPOUTR_VOL [5:0]	10_1101	Right Headphone Output Volume 000000 = -57dB 000001 = -56dB (... 1dB steps) 111001 = 0dB (... 1dB steps) 111110 = +5dB 111111 = +6dB

Table 39 Volume Control for HPOUTL and HPOUTR

REGISTER ADDRESS	BIT	LABEL	DEFAULT	DESCRIPTION
R59 (3Bh) Analogue OUT2 Left	8	LINEOUTL_MUTE	0	Left Line Output Mute 0 = Un-mute 1 = Mute
	7	LINEOUTVU	0	Line Output Volume Update Writing a 1 to this bit will update LINEOUTL and LINEOUTR volumes simultaneously. (Write-Only Register)
	6	LINEOUTLZC	0	Left Line Output Zero Cross Enable 0 = disabled 1 = enabled
	5:0	LINEOUTL_VOL [5:0]	11_1001	Left Line Output Volume 000000 = -57dB 000001 = -56dB (... 1dB steps) 111001 = 0dB (... 1dB steps) 111110 = +5dB 111111 = +6dB
R60 (3Ch) Analogue OUT2 Right	8	LINEOUTR_MUTE	0	Right Line Output Mute 0 = Un-mute 1 = Mute
	7	LINEOUTVU	0	Line Output Volume Update Writing a 1 to this bit will update LINEOUTL and LINEOUTR volumes simultaneously. (Write-Only Register)
	6	LINEOUTRZC	0	Right Line Output Zero Cross Enable 0 = disabled 1 = enabled
	5:0	LINEOUTR_VOL [5:0]	11_1001	Right Line Output Volume 000000 = -57dB 000001 = -56dB (... 1dB steps) 111001 = 0dB (... 1dB steps) 111110 = +5dB 111111 = +6dB

Table 40 Volume Control for LINEOUTL and LINEOUTR

REGISTER ADDRESS	BIT	LABEL	DEFAULT	DESCRIPTION
R62 (3Eh) Analogue OUT3 Left	8	SPKL_MUTE	1	Left Speaker Output Mute 0 = Un-mute 1 = Mute
	7	SPKVU	0	Speaker Output Volume Update Writing a 1 to this bit will update LON/LOP and RON/ROP volumes simultaneously. (Write-Only Register)
	6	SPKLZC	0	Left Speaker Output Zero Cross Enable 0 = disabled 1 = enabled
	5:0	SPKL_VOL [5:0]	11_1001	Left Speaker Output Volume 000000 = -57dB 000001 = -56dB (... 1dB steps) 111001 = 0dB (... 1dB steps) 111110 = +5dB 111111 = +6dB
R63 (3Fh) Analogue OUT3 Right	8	SPKR_MUTE	1	Right Speaker Output Mute 0 = Un-mute 1 = Mute
	7	SPKVU	0	Speaker Output Volume Update Writing a 1 to this bit will update LON/LOP and RON/ROP volumes simultaneously. (Write-Only Register)
	6	SPKRZC	0	Right Speaker Output Zero Cross Enable 0 = disabled 1 = enabled
	5:0	SPKR_VOL [5:0]	11_1001	Right Speaker Output Volume 000000 = -57dB 000001 = -56dB (... 1dB steps) 111001 = 0dB (... 1dB steps) 111110 = +5dB 111111 = +6dB

Table 41 Volume Control for LON/LOP and RON/ROP

## ANALOGUE OUTPUTS

The WM8910 has eight analogue output pins:

- Headphone outputs, HPOUTL and HPOUTR
- Line outputs, LINEOUTL and LINEOUTR
- Differential line outputs, LON/LOP and RON/ROP

The output signal paths and associated control registers are illustrated in Figure 26.

### HEADPHONE OUTPUTS – HPOUTL AND HPOUTR

The headphone outputs are designed to drive 16Ω or 32Ω headphones. These outputs are ground-referenced, i.e. no series capacitor is required between the pins and the headphone load. They are powered by an on-chip charge pump (see “Charge Pump” section). Signal volume at the headphone outputs is controlled as shown in Table 39.

The ground-referenced outputs incorporates a common mode, or ground loop, feedback path which provides rejection of system-related ground noise. The return path for the HPOUTL and HPOUTR outputs is via HPOUTFB. This pin must be connected to ground for normal operation of the headphone output. No register configuration is required.

### LINE OUTPUTS – LINEOUTL AND LINEOUTR

The line outputs are identical to the headphone outputs in design. They are ground-referenced and power by the on-chip charge pump. Signal volume at the headphone outputs is controlled as shown in Table 40.

Note that these outputs are intended for driving line loads, as the charge pump powering both the Headphone and Line outputs can only provide sufficient power to drive one set of headphones at any given time.

The ground-referenced outputs incorporates a common mode, or ground loop, feedback path which provides rejection of system-related ground noise. The return path for the LINEOUTL and LINEOUTR outputs is via LINEOUTFB. This pin must be connected to ground for normal operation of the line output. No register configuration is required.

### DIFFERENTIAL LINE OUTPUTS – LON/LOP AND RON/ROP

The differential line outputs are designed to differential line loads, including external loudspeaker drivers. The WM9001 is an ideal component for driving loudspeakers from these outputs. These pins are referenced to VMID (AVDD/2) and are powered directly from the AVDD supply.

Signal volume at the differential line outputs is controlled as shown in Table 41.

### EXTERNAL COMPONENTS FOR GROUND-REFERENCED OUTPUTS

In the case of the ground referenced outputs HPOUTL, HPOUTR, LINEOUTL and LINEOUTR, it is recommended to connect a zobel network to the audio output pins for best audio performance in all applications. The components of the zobel network have the effect of dampening high frequency oscillations or instabilities that can arise outside the audio band under certain conditions. Possible sources of these instabilities include the inductive load of a headphone coil or an active load in the form of an external line amplifier. The capacitance of lengthy cables or PCB tracks can also lead to amplifier instability. The zobel network should comprise a  $20\Omega$  resistor and  $100\text{nF}$  capacitor in series with each other, as illustrated in Figure 27.

Note that the zobel network is recommended for best audio quality and amplifier stability in all cases.

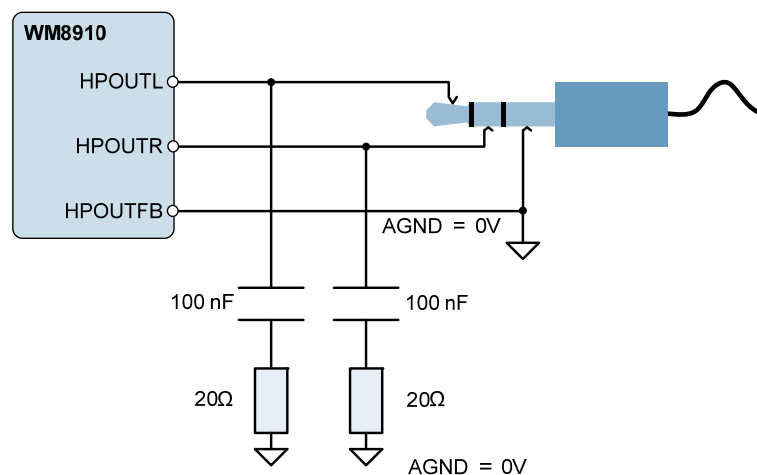

**Figure 27 Zobel Network Components for HPOUTL, HPOUTR, LINEOUTL and LINEOUTR**

The differential line outputs LOP/LON and ROP/RON would, typically, be connected to differential line drivers such as the WM9001 speaker driver. In such applications, a zobel network is not required on these differential line outputs.

## REFERENCE VOLTAGES AND MASTER BIAS

This section describes the analogue reference voltage and bias current controls. It also describes the VMID soft-start circuit for pop-free start-up and shut-down. Note that, under the recommended usage conditions of the WM8910, these features will be configured by running the default Start-Up and Shut-Down sequences as described in the "Control Write Sequencer" section. In these cases, the user does not need to set these register fields directly.

The analogue circuits in the WM8910 require a mid-rail analogue reference voltage, VMID. This reference is generated from AVDD via a programmable resistor chain. Together with the external VMID decoupling capacitor, the programmable resistor chain results in a slow, normal or fast charging characteristic on VMID. This is controlled by VMID\_RES [1:0], and can be used to optimise the reference for normal operation, low power standby or for fast start-up as described in Table 42. For normal operation, the VMID\_RES field should be set to 01.

The analogue circuits in the WM8910 require a bias current. The normal bias current is enabled by setting BIAS\_ENA. Note that the normal bias current source requires VMID to be enabled also. The normal bias current can also be controlled using the ISEL field as described in Table 42. This can be used to reduce power consumption, but may have a detrimental impact on audio performance in some usage modes. The default setting is recommended.

Note that the DAC and Output PGA bias circuits may also be adjusted in order to reduce power consumption. For details, see "Digital-to-Analogue Converter (DAC)" or "Output Signal Path".

An alternate bias current source (Start-Up Bias) is provided for pop-free start-up; this is selected using POBCTRL (see Table 43). Note that the default setting of POBCTRL selects the Start-Up Bias. The normal bias is only selected when POBCTRL is set to logic 0.

REGISTER ADDRESS	BIT	LABEL	DEFAULT	DESCRIPTION
R4 (04h) Bias Control 0	3:2	ISEL [1:0]	10	Master Bias control 00 = Normal bias x 0.5 01 = Normal bias x 0.75 10 = Normal bias 11 = Normal bias x 1.5
	0	BIAS_ENA	0	Enables the Normal bias current generator (for all analogue functions) 0 = Disabled 1 = Enabled
R5 (05h) VMID Control 0	2:1	VMID_RES [1:0]	00	VMID Divider Enable and Select 00 = VMID disabled (for OFF mode) 01 = 2 x 50kΩ divider (for normal operation) 10 = 2 x 250kΩ divider (for low power standby) 11 = 2 x 5kΩ divider (for fast start-up)

Table 42 Reference Voltages and Master Bias Enable

A pop-suppressed start-up requires VMID to be enabled smoothly, without the step change normally associated with the initial stage of the VMID capacitor charging. A pop-suppressed start-up also requires the analogue bias current to be enabled throughout the signal path prior to the VMID reference voltage being applied. The WM8910 incorporates pop-suppression circuits which address these requirements.

The alternate current source (Start-Up Bias) is enabled by STARTUP\_BIAS\_ENA. The start-up bias is selected (in place of the normal bias) by POBCTRL. It is recommended that the start-up bias is used during start-up, before switching back to the higher quality, normal bias.

VMID\_IO\_ENA has the same functionality as STARTUP\_BIAS\_ENA. The start-up bias is enabled by setting either of these bits.

A soft-start circuit is provided in order to control the switch-on of the VMID reference. The soft-start control circuit is enabled by setting VMID\_SOFT. Three slew rates are provided, under control of the VMID\_SOFT field. When the soft-start circuit is enabled prior to enabling VMID\_RES, the reference voltage rises smoothly, without the step change that would otherwise occur. It is recommended that the soft-start circuit and the output signal path be enabled before VMID is enabled by VMID\_RES.

A soft shut-down is provided, using the soft-start control circuit and the start-up bias current generator. The soft shut-down of VMID is achieved by setting VMID\_SOFT, STARTUP\_BIAS\_ENA and POBCTRL to select the start-up bias current and soft-start circuit prior to setting VMID\_RES=00.

REGISTER ADDRESS	BIT	LABEL	DEFAULT	DESCRIPTION
R4 (04h) Bias Control 0	4	POBCTRL	1	Selects the bias current source 0 = Normal bias 1 = Start-Up bias
	1	STARTUP_BIAS_ENA	0	Enables the Start-Up bias current generator 0 = Disabled 1 = Enabled
R5 (05h) VMID Control 0	5	VMID_IO_ENA	0	Enables the Start-Up bias current generator 0 = Disabled 1 = Enabled (same functionality as STARTUP_BIAS_ENA)
	4:3	VMID_SOFT [1:0]	10	VMID soft start enable / slew rate control 00 = Disabled 01 = Fast soft start 10 = Nominal soft start 11 = Slow soft start

Table 43 Soft Start Control

## POP SUPPRESSION CONTROL

The WM8910 incorporates Wolfson's SilentSwitch™ technology which enables pops normally associated with Start-Up, Shut-Down or signal path control to be suppressed. To achieve maximum benefit from these features, careful attention is required to the sequence and timing of these controls. Note that, under the recommended usage conditions of the WM8910, these features will be configured by running the default Start-Up and Shut-Down sequences as described in the "Control Write Sequencer" section. In these cases, the user does not need to set these register fields directly.

The Pop Suppression controls relating to the Headphone / Line Output drivers are described in the "Output Signal Path" section.

## DISABLED INPUT / OUTPUT CONTROL

The analogue inputs to the WM8910 and the Differential Line (Speaker) outputs are biased to VMID in normal operation. In order to avoid audible pops caused by a disabled signal path dropping to AGND, the WM8910 can maintain these connections at VMID when the relevant input or output stage is disabled. This is achieved by connecting a buffered VMID reference to the input or output. The buffered VMID reference is enabled by setting VMID\_BUF\_ENA.

When the buffered VMID reference is enabled, it is connected to any unused input pins by setting the BUFIO\_ENA register bit. When buffered VMID is enabled, it is connected to any disabled Differential Line outputs (speaker driver outputs) by setting VMID\_TIE\_ENA. The resistance associated with VMID\_TIE\_ENA can be either 500Ω or 20kΩ, depending on the VROI register bit.

REGISTER ADDRESS	BIT	LABEL	DEFAULT	DESCRIPTION
R5 (05h) VMID Control 0	7	VMID_TIE_ENA	0	VMID buffer to Differential Lineouts 0 = Disabled 1 = Enabled  (only applies when relevant outputs are disabled, ie. SPLK=0 or SPKR=0. Resistance is controlled by VROI.)
	6	BUFIO_ENA	0	VMID buffer to unused Inputs/Outputs 0 = Disabled 1 = Enabled
	0	VMID_BUF_ENA	0	VMID Buffer Enable 0 = Disabled 1 = Enabled
R65 (41h)	0	VROI	0	Select VMID_TIE_ENA resistance for disabled Differential Lineouts 0 = 20k ohm 1 = 500 ohm

Table 44 Disabled Input / Output Control

## DIFFERENTIAL LINE OUTPUT DISCHARGE CONTROL

The differential line output paths can be actively discharged to AGND through internal resistors if desired. This is desirable at start-up in order to achieve a known output stage condition prior to enabling the soft-start VMID reference voltage. This is also desirable in shut-down to prevent the external connections from being affected by the internal circuits. The Differential Line outputs (speaker driver outputs) can be discharged to AGND by setting SPK\_DISCHARGE.

REGISTER ADDRESS	BIT	LABEL	DEFAULT	DESCRIPTION
R65 (41h)	1	SPK_DISCHARGE	0	Speaker Discharge Enable 0 = Disabled 1 = Enable

Table 45 Differential Line Output Discharge Control

## CHARGE PUMP

The WM8910 incorporates a dual-mode Charge Pump which generates the supply rails for the headphone and line output drivers, HPOUTL, HPOUTR, and LINEOUTL and LINEOUTR. The Charge Pump has a single supply input, CPVDD, and generates split rails CPVOUTP and CPVOUTN according to the selected mode of operation. The Charge Pump connections are illustrated in Figure 28 (see the “Electrical Characteristics” section for external component values). An input decoupling capacitor may also be required at CPVDD, depending upon the system configuration.

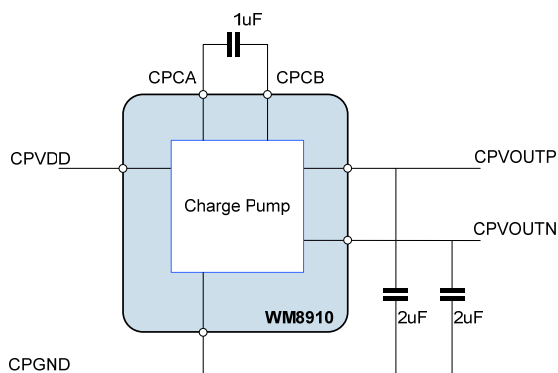

**Figure 28 Charge Pump External Connections**

The Charge Pump is enabled by setting the CP\_ENA bit. When enabled, the charge pump adjusts the output voltages (CPVOUTP and CPVOUTN) as well as the switching frequency in order to optimise the power consumption according to the operating conditions. This can take two forms, which are selected using the CP\_DYN\_PWR register bit.

- Register Control (CP\_DYN\_PWR = 0)
- Dynamic Control (CP\_DYN\_PWR = 1)

Under Register Control, the HPOUTL\_VOL, HPOUTR\_VOL, LINEOUTL\_VOL and LINEOUTR\_VOL register settings are used to control the charge pump mode of operation.

Under Dynamic Control, the audio signal level in the DAC is used to control the charge pump mode of operation. This is the Wolfson ‘Class W’ mode, which allows the power consumption to be optimised in real time, but can only be used if the DAC is the only signal source. This mode should not be used if any of the bypass paths are used to mix analogue inputs into the output signal path.

Under the recommended usage conditions of the WM8910, the Charge Pump will be enabled by running the default Start-Up sequence as described in the “Control Write Sequencer” section. (Similarly, it will be disabled by running the Shut-Down sequence.) In these cases, the user does not need to write to the CP\_ENA bit. The Charge Pump operating mode defaults to Register Control; Dynamic Control may be selected by setting the CP\_DYN\_PWR register bit, if appropriate.

When digital sidetone is used (see “Digital Mixing”), it is recommended that the Charge Pump operates in Register Control mode only (CP\_DYN\_PWR = 0). This is because the Dynamic Control mode (Class W) does not measure the sidetone signal level and hence the Charge Pump configuration cannot be optimised for all signal conditions when digital sidetone is enabled; this could lead to signal clipping.

The MCLK signal must be present for the charge pump to function. The clock division from MCLK is handled transparently by the WM8910 without user intervention, as long as MCLK and sample rates are set correctly (see “Clocking and Sample Rates” section). The clock divider ratio depends on the SAMPLE\_RATE [3:0], CLK\_SYS\_MODE [1:0], and CLK\_SYS\_RATE [3:0] register settings.

The charge pump requires a minimum CLK\_SYS frequency of 2.8224MHz.

The Charge Pump control fields are described in Table 46.

REGISTER ADDRESS	BIT	LABEL	DEFAULT	DESCRIPTION
R98 (62h) Charge Pump 0	0	CP_ENA	0	Enable charge-pump digits 0 = disable 1 = enable
R104 (68h) Class W 0	0	CP_DYN_PWR	0	Enable dynamic charge pump power control 0 = charge pump controlled by volume register settings 1 = charge pump controlled by real-time audio level

Table 46 Charge Pump Control

## DC SERVO

The WM8910 provides a DC servo circuit on the headphone and line outputs in order to remove DC offset from these ground-referenced outputs. When enabled, the DC servo ensures that the DC level of these outputs remains within 1.5mV of ground. Removal of the DC offset is important because any deviation from GND at the output pin will cause current to flow through the load under quiescent conditions, resulting in increased power consumption. Additionally, the presence of DC offsets can result in audible pops and clicks at power up and power down.

The recommended usage of the DC Servo is initialised by running the default Start-Up sequence as described in the “Control Write Sequencer” section. The default Start-Up sequence selects START\_STOP servo mode, which causes a one-off correction to be performed, after which the measured DC offset is then maintained on the headphone and line outputs.

If a different usage is required, e.g. if one or more of the outputs is not in use, or if periodic DC offset correction is required, then the default Start-Up sequence may be modified according to specific requirements. The relevant control fields are defined in Table 47 .

If DC offset correction is not required on any output, then DCS\_MASTER\_ENA should be set to 0. Setting this field to 0 before running the Start-Up sequence will disable the DC Servo on all outputs.

If DC offset correction is only required on selected channels, then DCS\_ENA should be set accordingly. Setting this field to 1111b enables the DC Servo on all outputs. Setting any bit to 0 disables the DC Servo on the corresponding output. Disabling the DC Servo on unused outputs reduces power consumption in the device. To modify this within the Start-Up sequence, the data in WSEQ Address 23 and WSEQ Address 24 should be updated (see “Control Write Sequencer”) before running the sequence.

If periodic updates to the DC offset correction is required, then DCS\_MODE should be modified. Setting this field to 11b selects START\_UPDATE servo mode, which causes the DC offset to be measured and corrected on a periodic basis. The default time between updates is approximately 10 minutes. Scheduling periodic updates enables the WM8910 to compensate for any change in DC offsets which might have occurred due to power supply drift or other factors. To modify this within the Start-Up sequence, the data in WSEQ Address 22 should be updated (see “Control Write Sequencer”) before running the sequence.

REGISTER ADDRESS	BIT	LABEL	DEFAULT	DESCRIPTION
R67 (43h) DC Servo 0	4	DCS_MASTER_ENA	1	DC Servo Master Control 0 = DC Servo Reset 1 = DC Servo Enabled
	3:0	DCS_ENA [3:0]	0000	DC Servo Enable [3] - HPOUTL enable [2] - HPOUTR enable [1] - LOU TL enable [0] - LOU TR enable
R69 (45h) DC Servo 2	1:0	DCS_MODE [1:0]	00	DC Servo Mode 00 = WRITE_STOP 01 = WRITE_UPDATE 10 = START_STOP 11 = START_UPDATE

Table 47 DC Servo Control

To reduce power consumption when unused audio outputs are disabled, the DC Servo correction should also be disabled. The WM8910 provides the capability to quickly resume the necessary DC Servo correction when the outputs are re-enabled, without the time delay associated with the START\_STOP mode of DC Servo operation.

If the DC Servo correction is disabled using the DCS\_ENA bits, but the DCS\_MASTER\_ENA bit is maintained at 1, then the DC Servo will retain the latest correction values in its memory. These values will be re-applied when the DC Servo is later enabled via the DCS\_ENA bits.

An alternative method to apply known correction settings is to read the correction values from the WM8910 register map and to store these for later use. After DC offset correction has been performed, the applicable correction values can be read from the fields in the Servo Readback registers R81 to R84 described in Table 48.

Setting DCS\_MODE to 00b or 01b selects WRITE\_STOP mode and WRITE\_UPDATE mode respectively. WRITE\_STOP mode is similar to START\_STOP mode, except that the DC Servo correction factors are read from internal registers, instead of being calculated from the measured output conditions. In the same way, WRITE\_UPDATE mode is similar to START\_UPDATE mode. When the DC Servo is commanded to one of these modes, the initial DC offset correction values are read from the \_WRITE\_VAL field in registers R71 to R74 described in Table 48.

Selecting WRITE\_STOP or WRITE\_UPDATE mode applies initial settings which should be written to registers R71 to R74 before the DC Servo is enabled. In WRITE\_STOP mode, no further DC correction is applied. In WRITE\_UPDATE mode, the DC Servo will periodically measure and adjust the DC offset correction. Similar to START\_UPDATE mode, the default time between updates is approximately 10 minutes.

REGISTER ADDRESS	BIT	LABEL	DEFAULT	DESCRIPTION
R71 (47h) DC Servo 4	7:0	DCS_HPOUTL_WRITE_VAL [7:0]	0000_0000	Value to send to Left Headphone Output Servo in a WRITE mode Two's complement format. LSB is 0.25mV. Range is +/-32mV
R72 (48h) DC Servo 5	7:0	DCS_HPOUTR_WRITE_VAL [7:0]	0000_0000	Value to send to Right Headphone Output Servo in a WRITE mode Two's complement format. LSB is 0.25mV. Range is +/-32mV
R73 (49h) DC Servo 6	7:0	DCS_LOUTL_WRITE_VAL [7:0]	0000_0000	Value to send to Left Line Output Servo in a WRITE mode Two's complement format. LSB is 0.25mV. Range is +/-32mV
R74 (4Ah) DC Servo 7	7:0	DCS_LOUTR_WRITE_VAL [7:0]	0000_0000	Value to send to Right Line Output Servo in a WRITE mode Two's complement format. LSB is 0.25mV. Range is +/-32mV
R81 (51h) DC Servo Readback 1	7:0	DCS_HPOUTL_INTEG [7:0]	0000_0000	Readback value on Left Headphone Output Servo. Two's complement format. LSB is 0.25mV. Range is +/-32mV (Read-Only Register)
R82 (52h) DC Servo Readback 2	7:0	DCS_HPOUTR_INTEG [7:0]	0000_0000	Readback value on Headphone Right Output Servo. Two's complement format. LSB is 0.25mV. Range is +/-32mV (Read-Only Register)
R83 (53h) DC Servo Readback 3	7:0	DCS_LOUTL_INTEG [7:0]	0000_0000	Readback value on Left Line Output Servo. Two's complement format. LSB is 0.25mV. Range is +/-32mV (Read-Only Register)
R84 (54h) DC Servo Readback 4	7:0	DCS_LOUTR_INTEG [7:0]	0000_0000	Readback value on Right Line Output Servo. Two's complement format. LSB is 0.25mV. Range is +/-32mV (Read-Only Register)

Table 48 DC Servo Initial Settings and Readback

## DIGITAL AUDIO INTERFACE

The digital audio interface is used for inputting DAC data into the WM8910 and outputting Digital Microphone data from it. The digital audio interface uses four pins:

- AIFTXDAT: Digital Microphone (DMIC) data output
- DACDAT: DAC data input
- LRC: DAC and DMIC data alignment clock
- BCLK: Bit clock, for synchronisation

The clock signals BCLK and LRCLK can be outputs when the WM8910 operates as a master, or inputs when it is a slave (see “Master And Slave Mode Operation” below).

Note that the BCLK pin can also support other functions, as described under “General Purpose Input/Output (GPIO)”. BCLK is the default function on this pin (GP5\_FN = 1h). Under default conditions, the other GPIO control fields for this pin have no effect.

Four different audio data formats are supported:

- Left justified
- Right justified
- I2S
- DSP mode

All four of these modes are MSB first. They are described in “Audio Data Formats (Normal Mode)” below. Refer to the “Signal Timing Requirements” section for timing information.

Time Division Multiplexing (TDM) is available in all four data format modes. The WM8910 can be programmed to send and receive data in one of two time slots.

PCM operation is supported using the DSP mode.

### MASTER AND SLAVE MODE OPERATION

The WM8910 digital audio interface can operate in master or slave mode, as shown in Figure 29 and Figure 30.

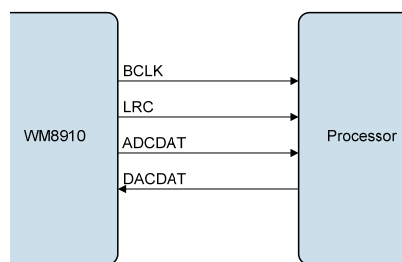

Figure 29 Master Mode

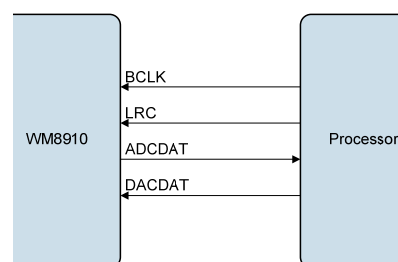

Figure 30 Slave Mode

In master mode, BCLK is derived from CLK\_SYS via a programmable division set by BCLK\_DIV.

In master mode, LRC is derived from BCLK via a programmable division set by LRCLK\_RATE. The BCLK input to this divider may be internal or external, allowing mixed master and slave modes.

The direction of these signals and the clock frequencies are controlled as described in the "Digital Audio Interface Control" section.

BCLK and LRC can be enabled as outputs in Slave mode, allowing mixed Master/Slave operation - see "Digital Audio Interface Control".

**OPERATION WITH TDM**

Time division multiplexing (TDM) allows multiple devices to transfer data simultaneously on the same bus. The WM8910 DMICs and DACs support TDM in master and slave modes for all data formats and word lengths. TDM is enabled and configured using register bits defined in the "Digital Audio Interface Control" section.

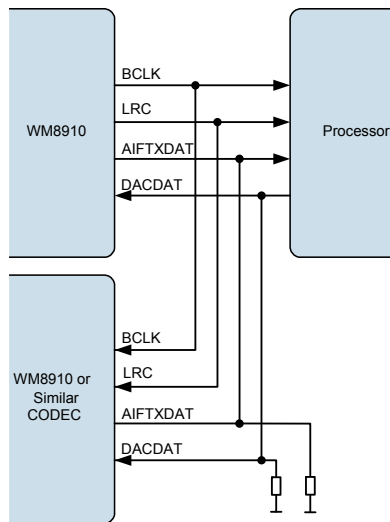

Figure 31 TDM with WM8910 as Master

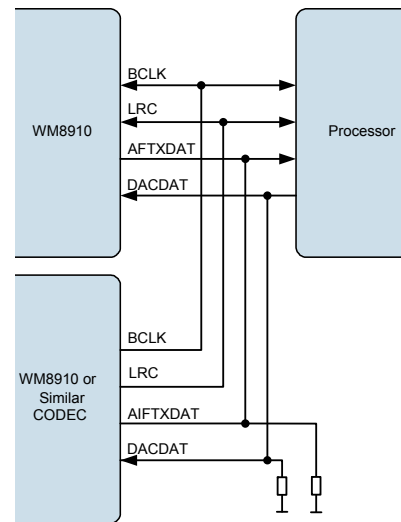

Figure 32 TDM with Other CODEC as Master

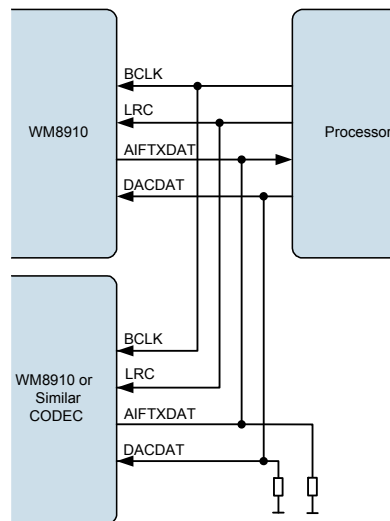

Figure 33 TDM with Processor as Master

**Note:** The WM8910 is a 24-bit device. If the user operates the WM8910 in 32-bit mode then the 8 LSBs will be ignored on the receiving side and not driven on the transmitting side. It is therefore recommended to add a pull-down resistor if necessary to the DACDAT line and the AIFTXDAT line in TDM mode.

**BCLK FREQUENCY**

The BCLK frequency is controlled relative to CLK\_SYS by the BCLK\_DIV divider. Internal clock divide and phase control mechanisms ensure that the BCLK and LRC edges will occur in a predictable and repeatable position relative to each other and relative to the data for a given combination of DAC/DMIC sample rate and BCLK\_DIV settings.

BCLK\_DIV is defined in the “Digital Audio Interface Control” section. See also the “Clocking and Sample Rates” section for more information.

**AUDIO DATA FORMATS (NORMAL MODE)**

In Right Justified mode, the LSB is available on the last rising edge of BCLK before a LRC transition. All other bits are transmitted before (MSB first). Depending on word length, BCLK frequency and sample rate, there may be unused BCLK cycles after each LRC transition.

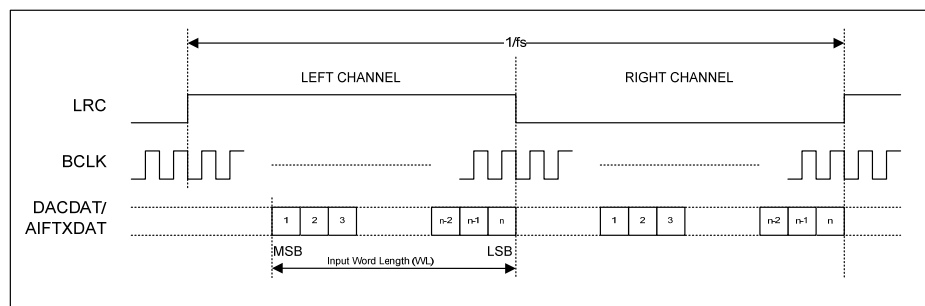

**Figure 34 Right Justified Audio Interface (assuming n-bit word length)**

In Left Justified mode, the MSB is available on the first rising edge of BCLK following a LRC transition. The other bits up to the LSB are then transmitted in order. Depending on word length, BCLK frequency and sample rate, there may be unused BCLK cycles before each LRC transition.

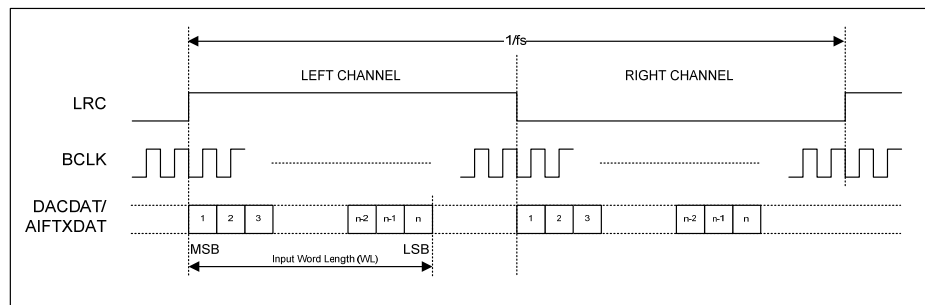

**Figure 35 Left Justified Audio Interface (assuming n-bit word length)**

In I<sup>2</sup>S mode, the MSB is available on the second rising edge of BCLK following a LRC transition. The other bits up to the LSB are then transmitted in order. Depending on word length, BCLK frequency and sample rate, there may be unused BCLK cycles between the LSB of one sample and the MSB of the next.

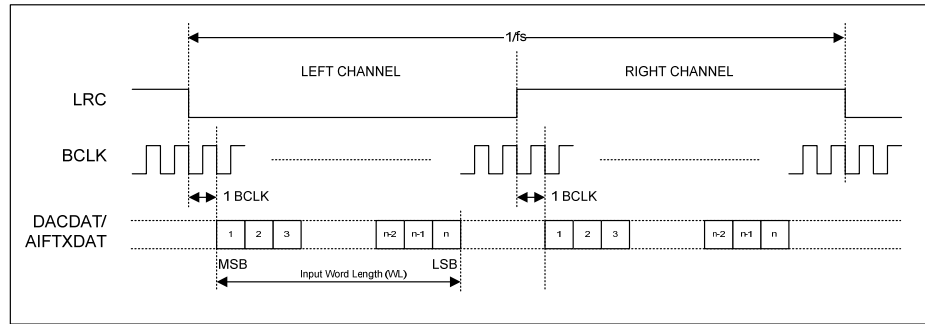

**Figure 36 I2S Justified Audio Interface (assuming n-bit word length)**

In DSP mode, the left channel MSB is available on either the 1<sup>st</sup> (mode B) or 2<sup>nd</sup> (mode A) rising edge of BCLK (selectable by AIF\_LRCLK\_INV) following a rising edge of LRC. Right channel data immediately follows left channel data. Depending on word length, BCLK frequency and sample rate, there may be unused BCLK cycles between the LSB of the right channel data and the next sample.

In device master mode, the LRC output will resemble the frame pulse shown in Figure 37 and Figure 38. In device slave mode, Figure 39 and Figure 40, it is possible to use any length of frame pulse less than 1/fs, providing the falling edge of the frame pulse occurs greater than one BCLK period before the rising edge of the next frame pulse.

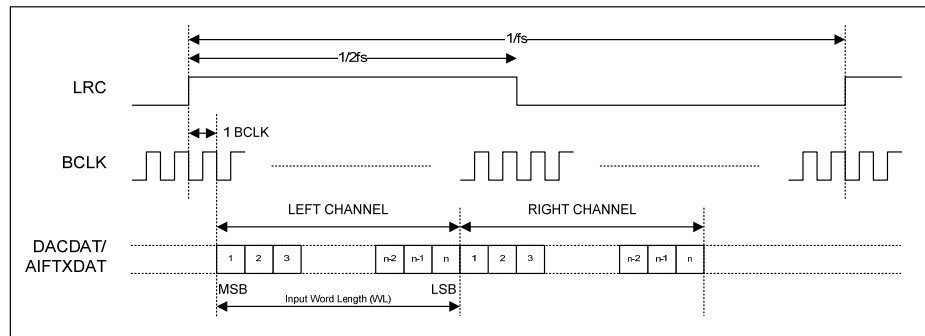

**Figure 37 DSP Mode Audio Interface (mode A, AIF\_LRCLK\_INV=0, Master)**

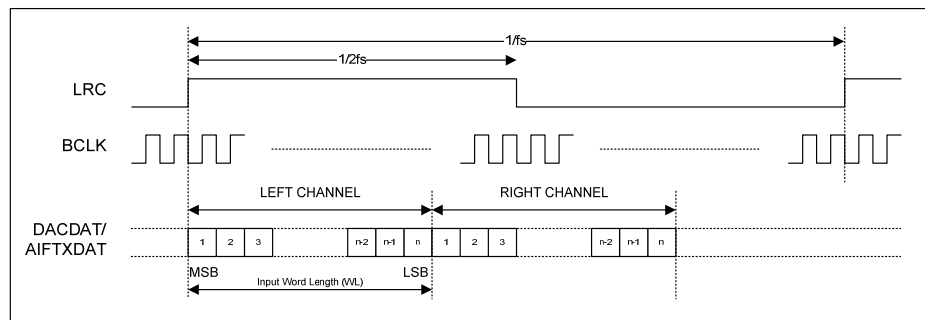

**Figure 38 DSP Mode Audio Interface (mode B, AIF\_LRCLK\_INV=1, Master)**

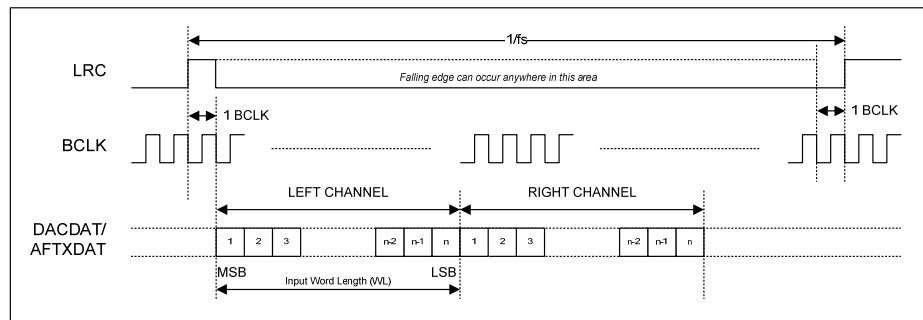

Figure 39 DSP Mode Audio Interface (mode A, AIF\_LRCLK\_INV=0, Slave)

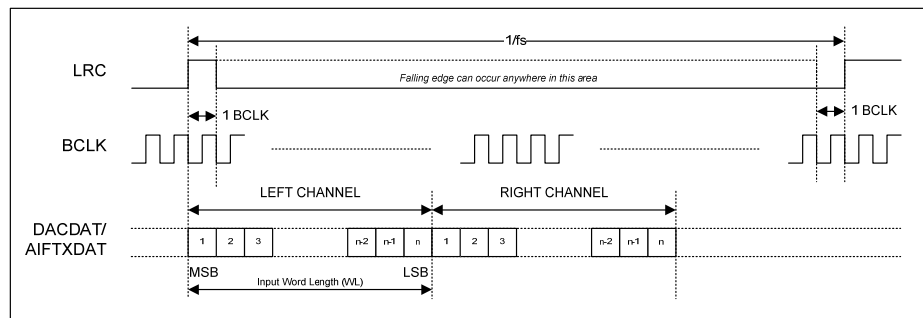

Figure 40 DSP Mode Audio Interface (mode B, AIF\_LRCLK\_INV=1, Slave)

PCM operation is supported in DSP interface mode. WM8910 Digital Microphone data that is output on the Left Channel will be read as mono PCM data by the receiving equipment. Mono PCM data received by the WM8910 will be treated as Left Channel data. This data may be routed to the Left/Right DACs as described in the “Digital Mixing” section.

### AUDIO DATA FORMATS (TDM MODE)

TDM is supported in master and slave mode and is enabled by register bits AIFTX\_TDM and AIFDAC\_TDM. All audio interface data formats support time division multiplexing (TDM) for Digital Microphone (DMIC) and DAC data.

Two time slots are available (Slot 0 and Slot 1), selected by register bits AIFTX\_TDM\_CHAN and AIFDAC\_TDM\_CHAN which control time slots for the DMIC data and the DAC data.

When TDM is enabled, the AIFTXDAT pin will be tri-stated immediately before and immediately after data transmission, to allow another audio device to drive this signal line for the remainder of the sample period. It is important that two audio devices do not attempt to drive the data pin simultaneously, as this could result in a short circuit. See “Audio Interface Timing” for details of the AIFTXDAT output relative to BCLK signal. Note that it is possible to ensure a gap exists between transmissions by setting the transmitted word length to a value higher than the actual length of the data. For example, if 32-bit word length is selected where only 24-bit data is available, then the WM8910 interface will tri-state after transmission of the 24-bit data; this creates an 8-bit gap after the WM8910’s TDM transmission slot.

When TDM is enabled, BCLK frequency must be high enough to allow data from both time slots to be transferred. The relative timing of Slot 0 and Slot 1 depends upon the selected data format as shown in Figure 41 to Figure 45.

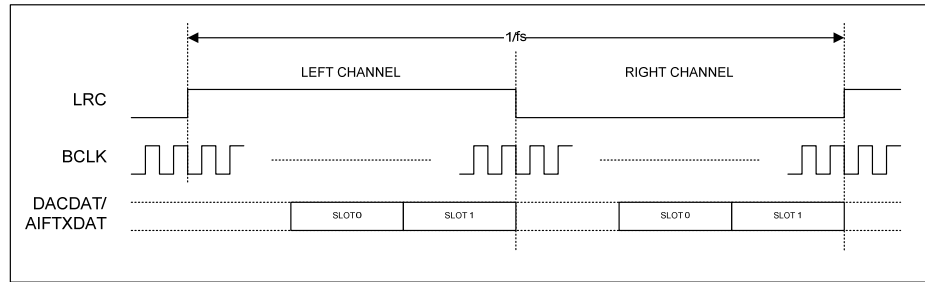

Figure 41 TDM in Right-Justified Mode

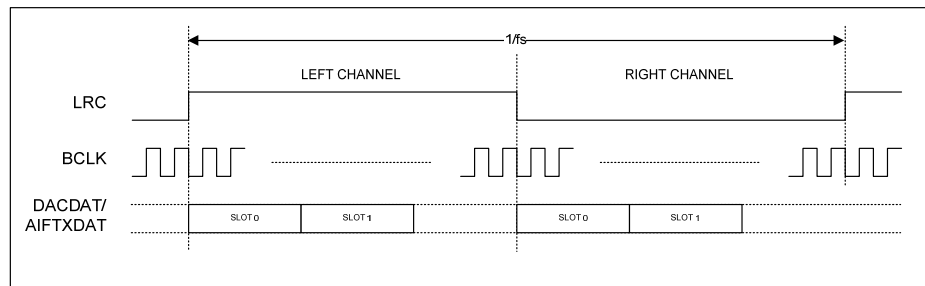

Figure 42 TDM in Left-Justified Mode

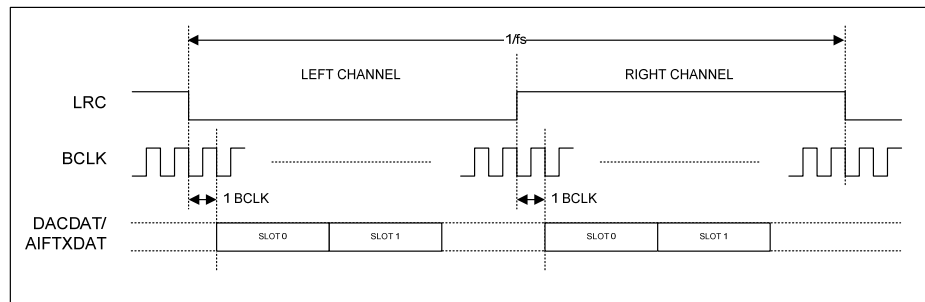

Figure 43 TDM in I²S Mode

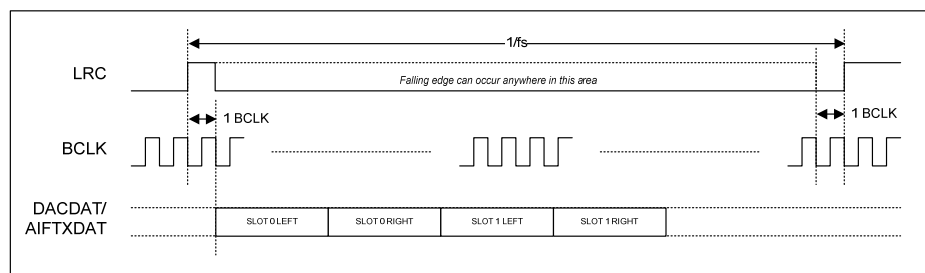

Figure 44 TDM in DSP Mode A

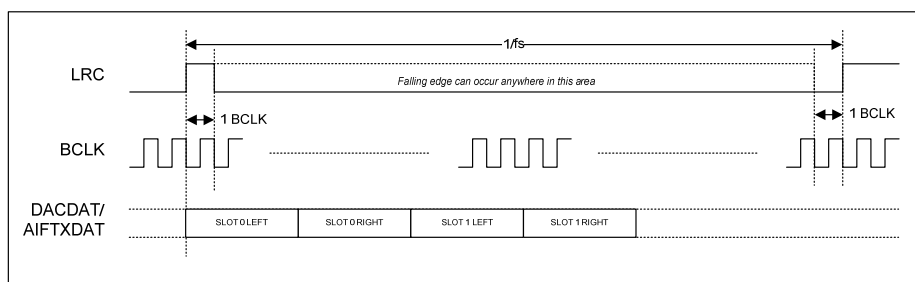

Figure 45 TDM in DSP Mode B

## DIGITAL AUDIO INTERFACE CONTROL

The register bits controlling audio data format, word length left/right channel data source and TDM are summarised in Table 49.

REGISTER ADDRESS	BIT	LABEL	DEFAULT	DESCRIPTION
R24 (18h) Audio Interface 0	12	DACL_DATINV	0	Left DAC Invert 0 = Left DAC output not inverted 1 = Left DAC output inverted
	11	DACR_DATINV	0	Right DAC Invert 0 = Right DAC output not inverted 1 = Right DAC output inverted
	7	AIFTXL_SRC	0	Left Digital Audio channel source 0 = Left DMIC data is output on left channel 1 = Right DMIC data is output on left channel
	6	AIFTXR_SRC	1	Right Digital Audio channel source 0 = Left DMIC data is output on right channel 1 = Right DMIC data is output on right channel
	5	AIFDACL_SRC	0	Left DAC Data Source Select 0 = Left DAC outputs left channel data 1 = Left DAC outputs right channel data
	4	AIFDACR_SRC	1	Right DAC Data Source Select 0 = Right DAC outputs left channel data 1 = Right DAC outputs right channel data
R25 (19h) Audio Interface 1	13	AIFDAC_TDM	0	DAC TDM Enable 0 = Normal DACDAT operation 1 = TDM enabled on DACDAT
	12	AIFDAC_TDM_CHAN	0	DACDAT TDM Channel Select 0 = DACDAT data input on slot 0 1 = DACDAT data input on slot 1
	11	AIFTX_TDM	0	Digital Microphone TDM Enable 0 = Normal AIFTXDAT operation 1 = TDM enabled on AIFTXDAT

REGISTER ADDRESS	BIT	LABEL	DEFAULT	DESCRIPTION
	10	AIFTX_TDM_CHAN	0	AIFTXDAT TDM Channel Select 0 = AIFTXDAT outputs data on slot 0 1 = AIFTXDAT output data on slot 1
	7	AIF_BCLK_INV	0	BCLK Invert 0 = BCLK not inverted 1 = BCLK inverted
	4	AIF_LRCLK_INV	0	LRC Polarity / DSP Mode A-B select.  Right, left and I <sup>2</sup> S modes – LRC polarity 0 = Not Inverted 1 = Inverted  DSP Mode – Mode A-B select 0 = MSB is available on 2nd BCLK rising edge after LRC rising edge (mode A) 1 = MSB is available on 1st BCLK rising edge after LRC rising edge (mode B)
	3:2	AIF_WL [1:0]	00	Digital Audio Interface Word Length 00 = 16 bits 01 = 20 bits 10 = 24 bits 11 = 32 bits
	1:0	AIF_FMT [1:0]	10	Digital Audio Interface Format 00 = Right Justified 01 = Left Justified 10 = I2S 11 = DSP
R38 (26h) DMIC Digital 0	1	TXL_DATINV	0	Left Digital Microphone Invert 0 = Left DMIC output not inverted 1 = Left DMIC output inverted
	0	TXR_DATINV	0	Right Digital Microphone Invert 0 = Right DMIC output not inverted 1 = Right DMIC output inverted

Table 49 Digital Audio Interface Data Control

Note that the WM8910 is a 24-bit device. In 32-bit mode (AIF\_WL=11), the 8 LSBs are ignored on the receiving side and not driven on the transmitting side.

### BCLK AND LRCLK CONTROL

The audio interface can be programmed to operate in master mode or slave mode using the BCLK\_DIR and LRCLK\_DIR register bits. In master mode, the BCLK and LRCLK signals are generated by the WM8910 when the Digital Microphone DSP or either of the DACs is enabled. In slave mode, the BCLK and LRCLK clock outputs are disabled by default to allow another digital audio interface to drive these pins.

It is also possible to force the BCLK or LRCLK signals to be output using BCLK\_DIR and LRCLK\_DIR, allowing mixed master and slave modes. The BCLK\_DIR and LRCLK\_DIR fields are defined in Table 50.

When BCLK is not selected ( $GP5\_FN \neq 1$ ), the WM8910 uses the MCLK input as the Bit Clock, provided that BCLK\_DIR is set to 0 to configure BCLK as an input, ie. BCLK slave mode. This configuration can offer power consumption benefits in addition to flexibility of GPIO functionality,

When the BCLK pin is an output (BCLK\_DIR=1), BCLK is derived from the internal CLK\_SYS signal (see "Clocking and Sample Rates"). In this case, the BCLK frequency is controlled in relation to CLK\_SYS by the BCLK\_DIV register field. When BCLK is an input, BCLK\_DIV has no effect.

When the LRC pin is an output (LRCLK\_DIR=1), LRC is derived from BCLK (irrespective of whether BCLK is an input or output). In this case, the LRC frequency is controlled in relation to BCLK by the LRCLK\_RATE register field. When LRC is an input, LRCLK\_RATE has no effect.

BCLK\_DIV and LRCLK\_RATE are defined in Table 50. The clocking scheme is illustrated in the "Clocking and Sample Rates" section - see Figure 48.

REGISTER ADDRESS	BIT	LABEL	DEFAULT	DESCRIPTION
R25 (19h) Audio Interface 1	9	LRCLK_DIR	0	Audio Interface LRC Direction 0 = LRC is input 1 = LRC is output
	6	BCLK_DIR	0	Audio Interface BCLK Direction 0 = BCLK is input 1 = BCLK is output
R26 (1Ah) Audio Interface 2	4:0	BCLK_DIV [4:0]	0_1000	BCLK Frequency (Master Mode) 00000 = CLK_SYS 00001 = Reserved 00010 = CLK_SYS / 2 00011 = CLK_SYS / 3 00100 = CLK_SYS / 4 00101 = CLK_SYS / 5 00110 = Reserved 00111 = CLK_SYS / 6 01000 = CLK_SYS / 8 (default) 01001 = CLK_SYS / 10 01010 = Reserved 01011 = CLK_SYS / 12 01100 = CLK_SYS / 16 01101 = CLK_SYS / 20 01110 = CLK_SYS / 22 01111 = CLK_SYS / 24 10000 = Reserved 10001 = CLK_SYS / 30 10010 = CLK_SYS / 32 10011 = CLK_SYS / 44 10100 = CLK_SYS / 48
R27 (1Bh) Audio Interface 3	10:0	LRCLK_RATE [10:0]	000_0010_0010	LRC Rate (Master Mode) LRC clock output = BCLK / LRCLK_RATE Integer (LSB = 1) Valid range: 8 to 2047 50:50 LRCLK duty cycle is only guaranteed with even values (8, 10, ... 2046).

Table 50 Digital Audio Interface Clock Control

**COMPANDING**

The WM8910 supports A-law and  $\mu$ -law companding on both transmit (Digital Microphone) and receive (DAC) sides as shown in Table 51.

REGISTER ADDRESS	BIT	LABEL	DEFAULT	DESCRIPTION
R24 (18h) Audio Interface 0	3	DMIC_COMP	0	DMIC Companding Enable 0 = disabled 1 = enabled
	2	DMIC_COMPMODE	0	DMIC Companding Type 0 = $\mu$ -law 1 = A-law
	1	DAC_COMP	0	DAC Companding Enable 0 = disabled 1 = enabled
	0	DAC_COMPMODE	0	DAC Companding Type 0 = $\mu$ -law 1 = A-law

**Table 51 Companding Control**

Companding uses a piecewise linear approximation of the following equations (as set out by ITU-T G.711 standard) for data compression:

$\mu$ -law (where  $\mu=255$  for the U.S. and Japan):

$$F(x) = \ln(1 + \mu|x|) / \ln(1 + \mu) \quad -1 \leq x \leq 1$$

A-law (where  $A=87.6$  for Europe):

$$F(x) = A|x| / (1 + \ln A) \quad x \leq 1/A$$

$$F(x) = (1 + \ln A|x|) / (1 + \ln A) \quad 1/A \leq x \leq 1$$

The companded data is also inverted as recommended by the G.711 standard (all 8 bits are inverted for  $\mu$ -law, all even data bits are inverted for A-law). The data will be transmitted as the first 8 MSBs of data.

Companding converts 13 bits ( $\mu$ -law) or 12 bits (A-law) to 8 bits using non-linear quantization. This provides greater precision for low amplitude signals than for high amplitude signals, resulting in a greater usable dynamic range than 8 bit linear quantization. The companded signal is an 8-bit word comprising sign (1 bit), exponent (3 bits) and mantissa (4 bits).

8-bit mode is selected whenever DAC\_COMP=1 or DMIC\_COMP=1. The use of 8-bit data allows samples to be passed using as few as 8 BCLK cycles per LRC frame. When using DSP mode B, 8-bit data words may be transferred consecutively every 8 BCLK cycles.

8-bit mode (without Companding) may be enabled by setting DAC\_COMPMODE=1 or DMIC\_COMPMODE=1, when DAC\_COMP=0 and DMIC\_COMP=0.

BIT7	BIT [6:4]	BIT [3:0]
SIGN	EXPONENT	MANTISSA

**Table 52 8-bit Companded Word Composition**

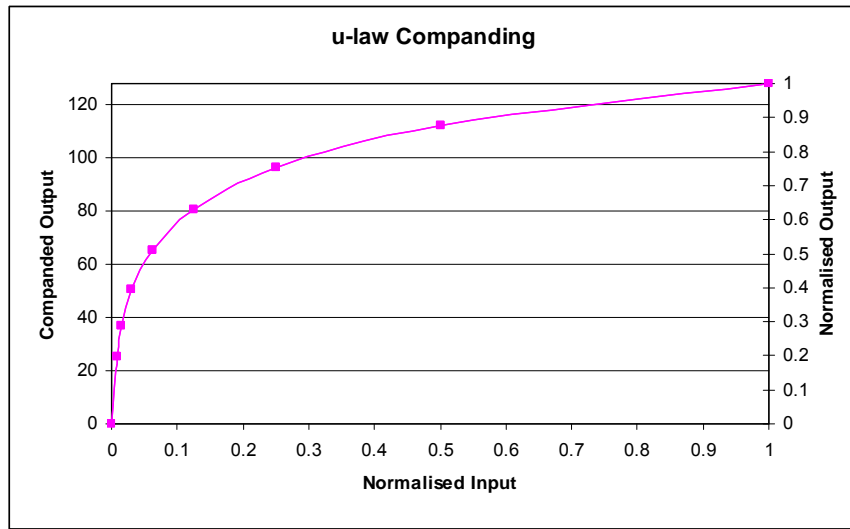

Figure 46  $\mu$ -Law Companding

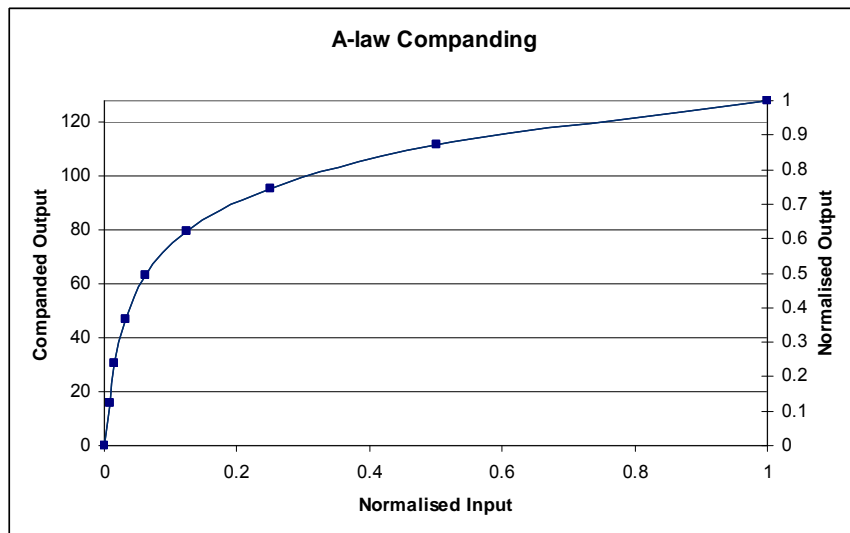

Figure 47 A-Law Companding

**LOOPBACK**

Setting the LOOPBACK register bit enables digital loopback. When this bit is set, the Digital Microphone data output is routed to the DAC digital data input path. The digital audio interface input (DACDAT) is not used when LOOPBACK is enabled.

REGISTER ADDRESS	BIT	LABEL	DEFAULT	DESCRIPTION
R24 (18h) Audio Interface 0	8	LOOPBACK	0	Digital Loopback Function 0 = No loopback 1 = Loopback enabled (Digital Microphone data output is directly input to DAC data input)

**Table 53 Loopback Control**

**Note:** When the digital sidetone is enabled, Digital Microphone data will continue to be added to DAC data when loopback is enabled.

**CLOCKING AND SAMPLE RATES**

The WM8910 DAC supports a wide range of standard audio sample rates from 8kHz to 96kHz. DAC oversample rates of 64fs or 128fs are supported (based on a 48kHz sample rate).

The Digital Microphone interface supports audio sample rates from 8kHz to 48kHz. When the DAC and the Digital Microphone interface are both enabled, they operate at the same sample rate,  $f_s$ .

The internal clocks for the WM8910 are all derived from a common internal clock source, CLK\_SYS. This clock is the reference for the DMIC, DACs, DSP core functions, digital audio interface, DC servo control and other internal functions.

CLK\_SYS can either be derived directly from MCLK, or may be generated from a Frequency Locked Loop (FLL) using MCLK, BCLK or LRC as a reference. Many commonly-used audio sample rates can be derived directly from typical MCLK frequencies; the FLL provides additional flexibility for a wide range of MCLK frequencies. To avoid audible glitches, all clock configurations must be set up before enabling playback. The FLL can be used to generate a free-running clock in the absence of an external reference source; see "Frequency Locked Loop (FLL)" for further details.

The WM8910 supports automatic clocking configuration. The programmable dividers associated with the Digital Microphone, DACs, DSP core functions and DC servo are configured automatically, with values determined from the SAMPLE\_RATE, CLK\_SYS\_RATE and CLK\_SYS\_MODE fields. Note that the user must also configure the Digital Audio Interface.

A 256kHz clock, supporting the Control Write Sequencer and other internal functions is derived from CLK\_SYS. This clock is enabled by WSMD\_CLK\_ENA.

A slow clock, TOCLK, is used to de-bounce the button/accessory detect inputs, and to set the timeout period for volume updates when zero-cross detect is used. This clock is enabled by TO\_ENA.

The Charge Pump and DC servo control functions are clocked from CLK\_SYS.

In master mode, BCLK is derived from CLK\_SYS via a programmable divider set by BCLK\_DIV. In master mode, the LRC is derived from BCLK via a programmable divider LRCLK\_RATE. The LRC can be derived from an internal or external BCLK source, allowing mixed master/slave operation.

The overall clocking scheme for the WM8910 is illustrated in Figure 48. Note that BCLK and LRC are described in the "Digital Audio Interface" section.

Figure 48 Clocking Overview

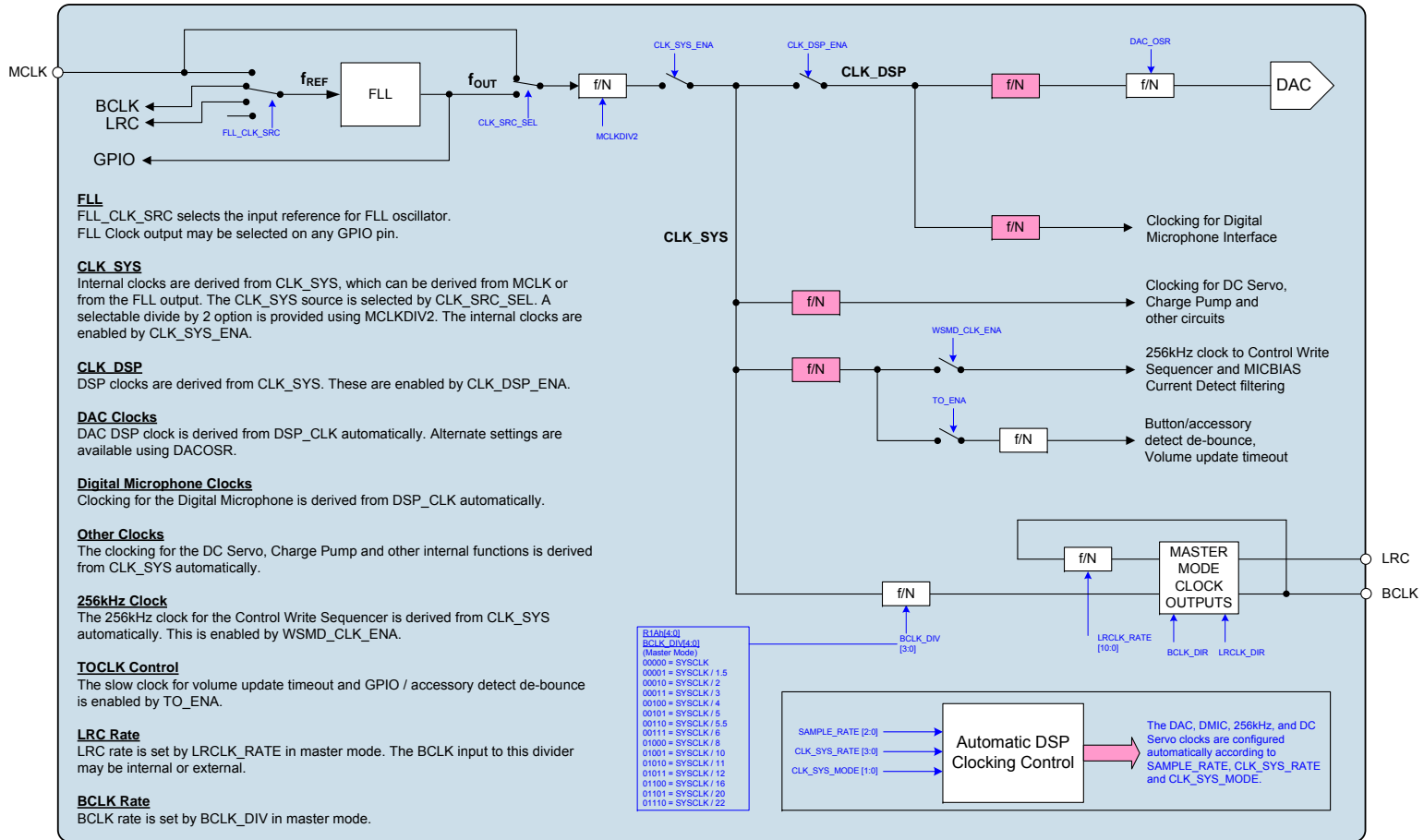

### CLK\_SYS CONTROL

The CLK\_SRC\_SEL bit is used to select the source for CLK\_SYS. The source may be either the MCLK input or the FLL output. The selected source may be adjusted by the MCLKDIV2 divider to generate CLK\_SYS. These register fields are described in Table 54. See “Frequency Locked Loop (FLL)” for more details of the Frequency Locked Loop clock generator.

The CLK\_SYS signal is enabled by register bit CLK\_SYS\_ENA. This bit should be set to 1 for normal operation with MCLK applied. This bit should be set to 0 when reconfiguring clock sources. It is not recommended to change CLK\_SRC\_SEL while the CLK\_SYS\_ENA bit is set.

The following operating frequency limits must be observed when configuring CLK\_SYS. Failure to observe these limits will result in degraded noise performance and/or incorrect DMIC/DAC functionality.

- If DAC\_OSR = 0 then  $\text{CLK\_SYS} \geq 3\text{MHz}$
- If DAC\_OSR = 1 then  $\text{CLK\_SYS} \geq 6\text{MHz}$

For DAC operation up to 48kHz sample rate, the following CLK\_SYS limits are applicable. These conditions are applicable whenever DACL\_ENA = 1 or DACR\_ENA = 1.

Note that the Digital Microphone operation limits must also be observed if either of the Digital Microphone DSP functions is enabled. See “Digital-to-Analogue Converter (DAC)” for definitions of DAC\_MONO and DAC\_OSR.

- If DAC\_MONO = 0 and DAC\_OSR = 0, then  $\text{CLK\_SYS} \geq 128 \times f_s$
- If DAC\_MONO = 0 and DAC\_OSR = 1, then  $\text{CLK\_SYS} \geq 256 \times f_s$
- If DAC\_MONO = 1 and DAC\_OSR = 0, then  $\text{CLK\_SYS} \geq 64 \times f_s$
- If DAC\_MONO = 1 and DAC\_OSR = 1, then  $\text{CLK\_SYS} \geq 128 \times f_s$

For Digital Microphone operation up to 48kHz sample rate, the following CLK\_SYS limit is applicable. This condition is applicable whenever DMICL\_ENA = 1 or DMICR\_ENA = 1.

Note that the DAC operation limits must also be observed if either DAC is enabled.

- $\text{CLK\_SYS} \geq 256 \times f_s$

Further requirements for 88.2kHz and 96kHz DAC operation are provided later in this section. Note that Digital Microphone operation at 88.2kHz or 96kHz is not possible.

The clocking of the Digital Microphone and DAC circuits is derived from CLK\_DSP, which is enabled by CLK\_DSP\_ENA. (Note that CLK\_SYS must also be enabled.)

A 256kHz clock required for the Control Write Sequencer is derived from CLK\_SYS. The 256kHz clock is enabled by WSMD\_CLK\_ENA.

The slow clock (TOCLK) required for input signal de-bouncing and volume update timeout functions is derived from the 256kHz clock. The TOCLK clock is enabled by TO\_ENA.

The CLK\_SYS control register fields are defined in Table 54.

REGISTER ADDRESS	BIT	LABEL	DEFAULT	DESCRIPTION
R20 (14h) Clock Rates 0	0	MCLKDIV2	0	Enables divide by 2 on MCLK 0 = CLK_SYS = MCLK 1 = CLK_SYS = MCLK / 2
R21 (15h) Clock Rates 1	15	CLK_SRC_SEL	0	SYSClk Source Select 0 = MCLK 1 = FLL output
R22 (16h) Clock Rates 2	2	CLK_SYS_ENA	0	System Clock enable 0 = Disabled 1 = Enabled
	1	CLK_DSP_ENA	0	DSP Clock enable 0 = Disabled 1 = Enabled
	0	TO_ENA	0	Zero Cross timeout enable 0 = Disabled 1 = Enabled
R108 (6Ch) Write Sequencer 0	8	WSMD_CLK_ENA	0	Write Sequencer Clock Enable 0 = Disabled 1 = Enabled

Table 54 MCLK and CLK\_SYS Control

### CONTROL INTERFACE CLOCKING

Register map access is possible with or without a Master Clock (MCLK). However, if CLK\_SYS\_ENA has been set to 1, then a Master Clock must be present for control register Read/Write operations. If CLK\_SYS\_ENA = 1 and MCLK is not present, then register access will be unsuccessful. (Note that read/write access to register R22, containing CLK\_SYS\_ENA, is always possible.)

If it cannot be assured that MCLK is present when accessing the register map, then it is required to set CLK\_SYS\_ENA = 0 to ensure correct operation.

It is possible to use the WM8910 analogue bypass paths to the differential line outputs (LON/LOP and RON/ROP) without MCLK. Note that MCLK is always required when using HPOUTL, HPOUTR, LINEOUTL or LINEOUTR.

### AUTOMATIC CLOCKING CONFIGURATION

The WM8910 supports a wide range of standard audio sample rates from 8kHz to 96kHz. The Automatic Clocking Configuration mode simplifies the configuration of the clock dividers in the WM8910 by deriving most of the necessary parameters from a minimum number of user registers.

The SAMPLE\_RATE field selects the sample rate, fs, of the Digital Microphone and DAC. Note that the same sample rate always applies to the Digital Microphone and DAC.

The CLK\_SYS\_RATE and CLK\_SYS\_MODE fields must be set according to the ratio of CLK\_SYS to fs. (Note that the internal clock CLK\_SYS is derived from MCLK as controlled by MCLKDIV2). When these fields are set correctly, the Sample Rate Decoder circuit automatically determines the clocking configuration for all other circuits within the WM8910.

The DSP clocking is enabled by CLK\_DSP\_ENA; see Table 54 for details of this register.

REGISTER ADDRESS	BIT	LABEL	DEFAULT	DESCRIPTION
R21 (15h) Clock Rates 1	13:10	CLK_SYS_RATE [3:0]	0011	CLK_SYS_RATE and CLK_SYS_MODE together determine the clock division ratio (CLK_SYS / fs); see Table 56
	9:8	CLK_SYS_MODE [1:0]	00	
	3:0	SAMPLE_RATE [3:0]	1000	Selects the Sample Rate (fs) 0000 = 8kHz 0001 = 11.025kHz 0010 = 12kHz 0011 = 16kHz 0100 = 22.05kHz 0101 = 24kHz 0110 = 32kHz 0111 = 44.1kHz 1000 = 48kHz 1001 = 88.2kHz (Not available for Digital Microphone.) 1010 = 96kHz (Not available for Digital Microphone.) 1011 to 1111 = Reserved  If the desired sample rate is not listed in this table, then the closest alternative should be chosen.

Table 55 Automatic Clocking Configuration Control

Available CLK_SYS / f <sub>s</sub> ratios				
		CLK_SYS_MODE		
		00 <i>(default)</i>	01 <i>(USB modes)</i>	10
CLK_SYS_RATE	0000	64	68	125
	0001	128	136	125
	0010	192	204	250
	0011	256	272	250
	0100	384	408	375
	0101	512	544	500
	0110	768	816	750
	0111	1024	1088	1000
	1000	1408	1496	1000
	1001	1536	1632	1500
	1010 to 1111	Reserved		

Table 56 Sample Rate Decoder Control

The clock division ratios available with CLK\_SYS\_MODE = 00 are suitable for use with standard audio master clocks. For example, with a 12.288MHz CLK\_SYS and 48kHz sample rate, the CLK\_SYS to fs ratio is 256. In this case, the required setting for CLK\_SYS\_RATE is 0011, as shown above.

### USB CLOCKING MODE

The clock division ratios with CLK\_SYS\_MODE = 01 or CLK\_SYS\_MODE = 10 allow compatibility with a 12MHz USB clock, at sample rates up to 48kHz. For example, with a 12MHz (USB) clock and 8kHz sample rate, the CLK\_SYS to fs ratio is 1500. In this case, the required setting for CLK\_SYS\_RATE is 1001.

Note that 44.1kHz and related sample rates are approximate when derived from a USB clock. For example, with a 12MHz MCLK and a division ratio of 272, the exact sample rate obtained is 44.118kHz rather than 44.1kHz. This 0.04% offset is inaudible and can be ignored. 48kHz and related sample rates are exact in all modes of operation, provided that MCLK itself is exact.

### DAC OPERATION AT 88.2K / 96K

The WM8910 supports DAC operation at 88.2kHz and 96kHz sample rates. This section details specific conditions applicable to these operating modes. Note that Digital Microphone operation at 88.2kHz or 96kHz is not possible.

For DAC operation at 88.2kHz or 96kHz sample rates, the available clocking configurations are detailed in Table 57.

Note that, for DAC operation at 88.2kHz or 96kHz sample rates, the Digital Microphone DSP functions must both be disabled (DMICL\_ENA = 0 and DMICR\_ENA = 0). Also, the DAC\_OSR register should be set to 0.

The CLK\_SYS frequency is derived from MCLK. Note that the maximum MCLK frequency is defined in the "Signal Timing Requirements" section.

SAMPLE RATE	REGISTER CONFIGURATION		CLK_SYS / fs RATIO
88.2kHz	SAMPLE_RATE = 1001 CLK_SYS_RATE = 0001	CLK_SYS_MODE = 00	128 x fs
		CLK_SYS_MODE = 01	136 x fs
		CLK_SYS_MODE = 10	125 x fs
96kHz	SAMPLE_RATE = 1010 CLK_SYS_RATE = 0001	CLK_SYS_MODE = 00	128 x fs
		CLK_SYS_MODE = 10	125 x fs

Table 57 DAC Operation at 88.2kHz and 96kHz Sample Rates

### DIGITAL MICROPHONE (DMIC) OPERATION

When a GPIO1 pin is configured as DMIC\_LR Clock output, the WM8910 outputs a clock which supports Digital Microphone operation at a multiple of the SAMPLE\_RATE (see Table 55). The precise clock frequency varies according to the MCLK frequency, the SAMPLE\_RATE field and other settings. The clock frequency is always within the range 1MHz - 3MHz, and some examples are shown in Table 58.

SAMPLE RATE	CLK_SYS	CLK_SYS RATIO	DMIC_LR FREQUENCY	DMIC_LR RATIO
8kHz	12.288MHz	1536fs	1.024MHz	128fs
8kHz	12MHz	1500fs	1.200MHz	150fs
16kHz	12.288MHz	768fs	2.048MHz	128fs
16kHz	12MHz	750fs	2.400MHz	150fs
48kHz	12.288MHz	256fs	1.536MHz	32fs
48kHz	12MHz	250fs	2.400MHz	50fs
44.1kHz	11.2896MHz	256fs	2.822MHz	64fs
44.1kHz	12MHz	272fs	3.000MHz	68fs
32kHz	12MHz	375fs	2.400MHz	75fs
24kHz	12MHz	500fs	2.400MHz	100fs
12kHz	12MHz	1000fs	1.500MHz	125fs

Table 58 Digital Microphone Clock

Note that the 88.2kHz and 96kHz sample rate settings are not valid for Digital Microphone operation.

## FREQUENCY LOCKED LOOP (FLL)

The integrated FLL can be used to generate CLK\_SYS from a wide variety of different reference sources and frequencies. The FLL can use either MCLK, BCLK or LRC as its reference, which may be a high frequency (eg. 12.288MHz) or low frequency (eg. 32.768kHz) reference. The FLL is tolerant of jitter and may be used to generate a stable CLK\_SYS from a less stable input signal. The FLL characteristics are summarised in "Electrical Characteristics".

Note that the FLL can be used to generate a free-running clock in the absence of an external reference source. This is described in the "Free-Running FLL Clock" section below.

The FLL is enabled using the FLL\_ENA register bit. Note that, when changing FLL settings, it is recommended that the digital circuit be disabled via FLL\_ENA and then re-enabled after the other register settings have been updated. When changing the input reference frequency  $F_{REF}$ , it is recommended the FLL be reset by setting FLL\_ENA to 0.

The FLL\_CLK\_SRC field allows MCLK, BCLK or LRC to be selected as the input reference clock.

The field FLL\_CLK\_REF\_DIV provides the option to divide the input reference (MCLK, BCLK or LRC) by 1, 2, 4 or 8. This field should be set to bring the reference down to 13.5MHz or below. For best performance, it is recommended that the highest possible frequency - within the 13.5MHz limit - should be selected.

The field FLL\_CTRL\_RATE controls internal functions within the FLL; it is recommended that only the default setting be used for this parameter. FLL\_GAIN controls the internal loop gain and should be set to the recommended value quoted in Table 61.

The FLL output frequency is directly determined from FLL\_FRATIO, FLL\_OUTDIV and the real number represented by FLL\_N and FLL\_K. The field FLL\_N is an integer (LSB = 1); FLL\_K is the fractional portion of the number (MSB = 0.5). The fractional portion is only valid in Fractional Mode when enabled by the field FLL\_FRAC.

It is recommended that fractional Mode (FLL\_FRAC = 1) is selected at all times. Power consumption in the FLL is reduced in integer mode; however, the performance may also be reduced, with increased noise or jitter on the output.

If low power consumption is required, then FLL settings must be chosen when N.K is an integer (ie. FLL\_K = 0). In this case, the fractional mode can be disabled by setting FLL\_FRAC = 0.

For best FLL performance, a non-integer value of N.K is required. In this case, the fractional mode must be enabled by setting FLL\_FRAC = 1. The FLL settings must be adjusted, if necessary, to produce a non-integer value of N.K.

The FLL output frequency is generated according to the following equation:

$$F_{OUT} = (F_{VCO} / FLL\_OUTDIV)$$

The FLL operating frequency,  $F_{VCO}$  is set according to the following equation:

$$F_{VCO} = (F_{REF} \times N.K \times FLL\_FRATIO)$$

See Table 61 for the coding of the FLL\_OUTDIV and FLL\_FRATIO fields.

$F_{REF}$  is the input frequency, as determined by FLL\_CLK\_REF\_DIV.

$F_{VCO}$  must be in the range 90-100 MHz. Frequencies outside this range cannot be supported.

Note that the output frequencies that do not lie within the ranges quoted above cannot be guaranteed across the full range of device operating temperatures.

In order to follow the above requirements for  $F_{VCO}$ , the value of FLL\_OUTDIV should be selected according to the desired output  $F_{OUT}$ , as described in Table 59. The divider, FLL\_OUTDIV, must be set so that  $F_{VCO}$  is in the range 90-100MHz.

OUTPUT FREQUENCY $F_{OUT}$	FLL_OUTDIV
2.8125 MHz - 3.125 MHz	4h (divide by 32)
5.625 MHz - 6.25 MHz	3h (divide by 16)
11.25 MHz - 12.5 MHz	2h (divide by 8)
22.5 MHz - 25 MHz	1h (divide by 4)

**Table 59 Selection of FLL\_OUTDIV**

The value of FLL\_FRATIO should be selected as described in Table 60.

REFERENCE FREQUENCY $F_{REF}$	FLL_FRATIO
1MHz - 13.5MHz	0h (divide by 1)
256kHz - 1MHz	1h (divide by 2)
128kHz - 256kHz	2h (divide by 4)
64kHz - 128kHz	3h (divide by 8)
Less than 64kHz	4h (divide by 16)

**Table 60 Selection of FLL\_FRATIO**

In order to determine the remaining FLL parameters, the FLL operating frequency,  $F_{VCO}$ , must be calculated, as given by the following equation:

$$F_{VCO} = (F_{OUT} \times FLL\_OUTDIV)$$

The value of FLL\_N and FLL\_K can then be determined as follows:

$$N.K = F_{VCO} / (FLL\_FRATIO \times F_{REF})$$

See Table 61 for the coding of the FLL\_OUTDIV and FLL\_FRATIO fields.

Note that  $F_{REF}$  is the input frequency, after division by FLL\_CLK\_REF\_DIV, where applicable.

In FLL Fractional Mode, the fractional portion of the N.K multiplier is held in the FLL\_K register field. This field is coded as a fixed point quantity, where the MSB has a weighting of 0.5. Note that, if desired, the value of this field may be calculated by multiplying K by  $2^{16}$  and treating FLL\_K as an integer value, as illustrated in the following example:

$$\text{If } N.K = 8.192, \text{ then } K = 0.192$$

$$\text{Multiplying } K \text{ by } 2^{16} \text{ gives } 0.192 \times 65536 = 12582.912 \text{ (decimal)}$$

$$\text{Apply rounding to the nearest integer} = 12583 \text{ (decimal)} = 3127 \text{ (hex)}$$

For best performance, FLL Fractional Mode should always be used. Therefore, if the calculations yield an integer value of N.K, then it is recommended to adjust FLL\_FRATIO in order to obtain a non-integer value of N.K. Care must always be taken to ensure that the FLL operating frequency,  $F_{VCO}$ , is within its recommended limits of 90-100 MHz.

The register fields that control the FLL are described in Table 61. Example settings for a variety of reference frequencies and output frequencies are shown in Table 62.

REGISTER ADDRESS	BIT	LABEL	DEFAULT	DESCRIPTION
R128 (80h) FLL Control 1	7:4	FLL_GAIN [3:0]	0h	Gain applied to error 0000 = x 1 (Recommended value) 0001 = x 2 0010 = x 4 0011 = x 8 0100 = x 16 0101 = x 32 0110 = x 64 0111 = x 128 1000 = x 256  Recommended that this register is not changed from default.
	3	FLL_HOLD	0	FLL Hold Select 0 = Disabled 1 = Enabled  This feature enables free-running mode in FLL when reference clock is removed
	2	FLL_FRAC	0	Fractional enable 0 = Integer Mode 1 = Fractional Mode  Fractional Mode is recommended in all cases
	0	FLL_ENA	0	FLL Enable 0 = Disabled 1 = Enabled
R129 (81h) FLL Control 2	12:1 1	FLL_CLK_SRC [1:0]	00	FLL Clock source 00 = MCLK 01 = BCLK 10 = LRC 11 = Reserved
	10:9	FLL_CLK_REF_DIV [1:0]	00	FLL Clock Reference Divider 00 = MCLK / 1 01 = MCLK / 2 10 = MCLK / 4 11 = MCLK / 8  MCLK (or other input reference) must be divided down to <=13.5MHz. For lower power operation, the reference clock can be divided down further if desired.

REGISTER ADDRESS	BIT	LABEL	DEFAULT	DESCRIPTION
	8:6	FLL_CTRL_RATE [2:0]	000	Frequency of the FLL control block 000 = $F_{VCO} / 1$ (Recommended value) 001 = $F_{VCO} / 2$ 010 = $F_{VCO} / 3$ 011 = $F_{VCO} / 4$ 100 = $F_{VCO} / 5$ 101 = $F_{VCO} / 6$ 110 = $F_{VCO} / 7$ 111 = $F_{VCO} / 8$  Recommended that this register is not changed from default.
	5:3	FLL_OUTDIV [2:0]	000	$F_{OUT}$ clock divider 000 = 2 001 = 4 010 = 8 011 = 16 100 = 32 101 = 64 110 = 128 111 = 256  ( $F_{OUT} = F_{VCO} / FLL\_OUTDIV$ )
	2:0	FLL_FRATIO [2:0]	000	$F_{VCO}$ clock divider 000 = divide by 1 001 = divide by 2 010 = divide by 4 011 = divide by 8 1XX = divide by 16  000 recommended for $F_{REF} > 1\text{MHz}$ 100 recommended for $F_{REF} < 64\text{kHz}$
R130 (82h) FLL Control 3	15:0	FLL_K [15:0]	0000h	Fractional multiply for $F_{REF}$ (MSB = 0.5)
R131 (83h) FLL Control 4	9:0	FLL_N [9:0]	000h	Integer multiply for $F_{REF}$ (LSB = 1)

Table 61 FLL Register Map

### FREE-RUNNING FLL CLOCK

The FLL can generate a clock signal even when the external reference is removed. It should be noted that the accuracy of this clock is reduced, and a reference source should always be used where possible. In free-running modes, the FLL is not sufficiently accurate for hi-fi audio applications. The free-running modes are suitable for clocking other functions, including the Write Sequencer and DC servo control. The free-running mode can be used to support the analogue input (bypass) audio paths.

A clock reference is required for initial configuration of the FLL as described above. For free-running operation, the FLL\_HOLD bit should be set, as described in Table 61. When FLL\_HOLD is set, the FLL will continue to generate a stable output clock after the reference input is stopped or disconnected.

Note that the FLL must be selected as the CLK\_SYS source by setting CLK\_SRC\_SEL (see Table 54). Note that, in the absence of any reference clock, the FLL output is subject to a very wide tolerance. See "Electrical Characteristics" for details of the FLL accuracy.

### GPIO OUTPUTS FROM FLL

The WM8910 has an internal signal which indicates whether the FLL Lock has been achieved. The FLL Lock status is an input to the Interrupt control circuit and can be used to trigger an Interrupt event - see "Interrupts".

The FLL Lock signal can be output directly on a GPIO pin as an external indication of FLL Lock. See "General Purpose Input/Output (GPIO)" for details of how to configure a GPIO pin to output the FLL Lock signal.

The FLL Clock can be output directly on a GPIO pin as a clock signal for other circuits. Note that the FLL Clock may be output even if the FLL is not selected as the WM8910 CLK\_SYS source. The clocking configuration is illustrated in Figure 48. See "General Purpose Input/Output (GPIO)" for details of how to configure a GPIO pin to output the FLL Clock.

### EXAMPLE FLL CALCULATION

To generate 12.288 MHz output ( $F_{OUT}$ ) from a 12.000 MHz reference clock ( $F_{REF}$ ):

- Set FLL\_CLK\_REF\_DIV in order to generate  $F_{REF} \leq 13.5\text{MHz}$ :  
FLL\_CLK\_REF\_DIV = 00 (divide by 1)
- Set FLL\_CTRL\_RATE to the recommended setting:  
FLL\_CTRL\_RATE = 000 (divide by 1)
- Set FLL\_GAIN to the recommended setting:  
FLL\_GAIN = 0000 (multiply by 1)
- Set FLL\_OUTDIV for the required output frequency as shown in Table 59:-  
 $F_{OUT} = 12.288\text{ MHz}$ , therefore FLL\_OUTDIV = 2h (divide by 8)
- Set FLL\_FRATIO for the given reference frequency as shown in Table 60:  
 $F_{REF} = 12\text{MHz}$ , therefore FLL\_FRATIO = 0h (divide by 1)
- Calculate  $F_{VCO}$  as given by  $F_{VCO} = F_{OUT} \times FLL\_OUTDIV$ :-  
 $F_{VCO} = 12.288 \times 8 = 98.304\text{MHz}$
- Calculate N.K as given by  $N.K = F_{VCO} / (FLL\_FRATIO \times F_{REF})$ :  
 $N.K = 98.304 / (1 \times 12) = 8.192$
- Determine FLL\_N and FLL\_K from the integer and fractional portions of N.K:-  
FLL\_N is 8. FLL\_K is 0.192
- Confirm that N.K is a fractional quantity and set FLL\_FRAC:  
N.K is fractional. Set FLL\_FRAC = 1.  
Note that, if N.K is an integer, then an alternative value of FLL\_FRATIO should be selected in order to produce a fractional value of N.K.

**EXAMPLE FLL SETTINGS**

Table 62 provides example FLL settings for generating common CLK\_SYS frequencies from a variety of low and high frequency reference inputs.

F <sub>REF</sub>	F <sub>OUT</sub>	FLL_CLK_REF_DIV	F <sub>VCO</sub>	FLL_N	FLL_K	FLL_FRATIO	FLL_OUTDIV	FLL_FRAC
32.000 kHz	12.288 MHz	Divide by 1 (0h)	98.304 MHz	192 (0C0h)	0 (0000h)	16 (4h)	8 (2h)	0
32.000 kHz	11.2896 MHz	Divide by 1 (0h)	90.3168 MHz	176 (0B0h)	0.4 (6666h)	16 (4h)	8 (2h)	1
32.768 kHz	12.288 MHz	Divide by 1 (0h)	98.304 MHz	187 (0BBh)	0.5 (8000h)	16 (4h)	8 (2h)	1
32.768 kHz	11.288576 MHz	Divide by 1 (0h)	90.3086 MHz	172 (0ACh)	0.25 (4000h)	16 (4h)	8 (2h)	1
32.768 kHz	11.2896 MHz	Divide by 1 (0h)	90.3168 MHz	172 (0ACh)	0.2656 (4400h)	16 (4h)	8 (2h)	1
48 kHz	12.288 MHz	Divide by 1 (0h)	98.304 MHz	128 (080h)	0 (0000h)	16 (4h)	8 (2h)	0
11.3636 MHz	12.368544 MHz	Divide by 1 (0h)	98.9484 MHz	8 (008h)	0.707483 (B51Eh)	1 (0h)	8 (2h)	1
12.000 MHz	12.288 MHz	Divide by 1 (0h)	98.304 MHz	8 (008h)	0.192 (3127h)	1 (0h)	8 (2h)	1
12.000 MHz	11.289597 MHz	Divide by 1 (0h)	90.3168 MHz	7 (007h)	0.526398 (86C2h)	1 (0h)	8 (2h)	1
12.288 MHz	12.288 MHz	Divide by 1 (0h)	98.304 MHz	8 (008h)	0 (0000h)	1 (0h)	8 (2h)	0
12.288 MHz	11.2896 MHz	Divide by 1 (0h)	90.3168 MHz	7 (007h)	0.35 (599Ah)	1 (0h)	8 (2h)	1
13.000 MHz	12.287990 MHz	Divide by 1 (0h)	98.3039 MHz	7 (007h)	0.56184 (8FD5h)	1 (0h)	8 (2h)	1
13.000 MHz	11.289606 MHz	Divide by 1 (0h)	90.3168 MHz	6 (006h)	0.94745 (F28Ch)	1 (0h)	8 (2h)	1
19.200 MHz	12.287988 MHz	Divide by 2 (1h)	98.3039 MHz	10 (00Ah)	0.23999 (3D70h)	1 (0h)	8 (2h)	1
19.200 MHz	11.289588 MHz	Divide by 2 (1h)	90.3167 MHz	9 (009h)	0.40799 (6872h)	1 (0h)	8 (2h)	1

**Table 62 Example FLL Settings**

## GENERAL PURPOSE INPUT/OUTPUT (GPIO)

The WM8910 provides five multi-function pins which can be configured to provide a number of different functions. These are digital input/output pins on the DBVDD power domain. The GPIO pins are:

- GPIO1
- GPIO2
- GPIO3 / ADDR
- INTERRUPT / GPIO4
- BCLK / GPIO5

Each general purpose I/O pin can be configured to be a GPIO input or configured as one of a number of output functions. Signal de-bouncing can be selected on GPIO input pins for use with jack/button detect applications. Table 63 lists the functions that are available on each of these pins. The default function is highlighted for each pin.

GPIO Pin Function	GPIO PINS				
	GPIO1	GPIO2	GPIO3/ ADDR	INTERRUPT/ GPIO4	BCLK/ GPIO5
GPIO output	Yes	Yes	Yes	Yes	Yes
BCLK input/output	No	No	No	No	Yes
Interrupt output (IRQ)	Yes	Yes	Yes	Yes	Yes
Digital Microphone Clock (DMIC_LR)	Yes	Yes	Yes	Yes	No
Digital Microphone Data (DMIC_DAT)	No	Yes	Yes	No	No
GPIO input (including jack/button detect)	Yes	Yes	Yes	Yes	Yes
MICBIAS Current detect output	Yes	Yes	Yes	Yes	Yes
MICBIAS Short Circuit detect output	Yes	Yes	Yes	Yes	Yes
FLL Lock output	Yes	Yes	Yes	Yes	Yes
FLL Clock output	Yes	Yes	Yes	Yes	Yes

**Table 63 GPIO Functions Available**

The register fields that control the functionality of these pins are described in Table 64. For each pin, the selected function is determined by the GPn\_FN field, where n identifies the GPIO pin (1 to 5). Note that the INTERRUPT pin is also referred to as GPIO4; the BCLK pin is also referred to as GPIO5.

The pin direction, set by GPn\_DIR, must be set according to the function selected by GPn\_FN.

The characteristics of any pin selected as an output may be controlled by setting GPn\_OP\_CFG - an output pin may be either CMOS or Open-Drain. When a pin is configured as a GPIO output, its level can be set to logic 0 or logic 1 using the GPn\_LVL field.

A pin configured as a GPIO input can be used to trigger an Interrupt event. This input may be configured as active high or active low using the GPn\_IP\_CFG field. De-bouncing of this input may be enabled using the GPn\_DB field. Internal pull-up and pull-down resistors may be enabled using the GPn\_PU and GPn\_PD fields. (Note that if GPn\_PU and GPn\_PD are both set for any GPIO pin, then the pull-up and pull-down will be disabled.)

Each of the GPIO pins is an input to the Interrupt control circuit and can be used to trigger an Interrupt event. The register field GPn\_INTMODE selects edge detect or level detect Interrupt functionality. Edge detect raises an interrupt on rising and falling transitions. Level detect asserts the interrupt for as long as the GPIO status is asserted. See "Interrupts".

The Digital Microphone Interface and MICBIAS Current Detect functions are described in the “Analogue Input Signal Path” section.

Interrupt Output is the default function of GPIO4. See “Interrupts” for further details.

BCLK is the default function of GPIO5. This may be input or output. Note that, when BCLK is enabled on this pin (GP5\_FN = 1h), the other GPIO control fields for this pin have no effect. When BCLK is not enabled on this pin (GP5\_FN ≠ 1h), the WM8910 uses the MCLK input as the Bit Clock. See “Digital Audio Interface Control” for further details.

REGISTER ADDRESS	BIT	LABEL	DEFAULT	DESCRIPTION
R116 (74h) GPIO Control 1	13:8	GP1_FN [5:0]	00_0000	GPIO 1 Pin Function select 00h = GPIO output 01h = Reserved 02h = IRQ output 03h = GPIO input 04h = Reserved 05h = Reserved 06h = DMIC_LR Clock output 07h = Reserved 08h = FLL Lock output 09h = FLL Clock output 0Ah to 3Fh = Reserved
	7	GP1_DIR	1	GPIO Pin Direction 0 = Output 1 = Input
	6	GP1_OP_CFG	0	Output pin configuration 0 = CMOS 1 = Open-drain
	5	GP1_IP_CFG	1	Input pin configuration 0 = Active low 1 = Active high
	4	GP1_LVL	0	GPIO Output Level (when GP1_FN = 00000) 0 = Logic 0 1 = Logic 1
	3	GP1_PD	1	GPIO Pull-Down Enable 0 = Pull-down disabled 1 = Pull-down enabled (Approx 100kΩ)
	2	GP1_PU	0	GPIO Pull-Up Enable 0 = Pull-up disabled 1 = Pull-up enabled (Approx 100kΩ)
	1	GP1_INTMODE	0	GPIO Interrupt Mode 0 = Level triggered 1 = Edge triggered
	0	GP1_DB	0	GPIO de-bounce 0 = GPIO is not debounced 1 = GPIO is debounced

REGISTER ADDRESS	BIT	LABEL	DEFAULT	DESCRIPTION
R117 (75h) GPIO Control 2	13:8	GP2_FN [5:0]	00_0000	GPIO 2 Pin Function select 00h = GPIO output 01h = Reserved 02h = IRQ output 03h = GPIO input 04h = Reserved 05h = Reserved 06h = DMIC_DAT Data input 07h = DMIC_LR Clock output 08h = FLL Lock output 09h = FLL Clock output 0Ah to 3Fh = Reserved
	7	GP2_DIR	1	GPIO Pin Direction 0 = Output 1 = Input
	6	GP2_OP_CFG	0	Output pin configuration 0 = CMOS 1 = Open-drain
	5	GP2_IP_CFG	1	Input pin configuration 0 = Active low 1 = Active high
	4	GP2_LVL	0	GPIO Output Level (when GP2_FN = 00000) 0 = Logic 0 1 = Logic 1
	3	GP2_PD	1	GPIO Pull-Down Enable 0 = Pull-down disabled 1 = Pull-down enabled (Approx 100kΩ)
	2	GP2_PU	0	GPIO Pull-Up Enable 0 = Pull-up disabled 1 = Pull-up enabled (Approx 100kΩ)
	1	GP2_INTMODE	0	GPIO Interrupt Mode 0 = Level triggered 1 = Edge triggered
	0	GP2_DB	0	GPIO de-bounce 0 = GPIO is not debounced 1 = GPIO is debounced
R118 (76h) GPIO Control 3	13:8	GP3_FN [5:0]	00_0000	GPIO 3 Pin Function select 00h = GPIO output 01h = Reserved 02h = IRQ output 03h = GPIO input 04h = Reserved 05h = Reserved 06h = DMIC_DAT Data input 07h = DMIC_LR Clock output 08h = FLL Lock output 09h = FLL Clock output 0Ah to 3Fh = Reserved
	7	GP3_DIR	1	GPIO Pin Direction 0 = Output 1 = Input

REGISTER ADDRESS	BIT	LABEL	DEFAULT	DESCRIPTION
	6	GP3_OP_CFG	0	Output pin configuration 0 = CMOS 1 = Open-drain
	5	GP3_IP_CFG	1	Input pin configuration 0 = Active low 1 = Active high
	4	GP3_LVL	0	GPIO Output Level (when GP3_FN = 00000) 0 = Logic 0 1 = Logic 1
	3	GP3_PD	1	GPIO Pull-Down Enable 0 = Pull-down disabled 1 = Pull-down enabled (Approx 100kΩ)
	2	GP3_PU	0	GPIO Pull-Up Enable 0 = Pull-up disabled 1 = Pull-up enabled (Approx 100kΩ)
	1	GP3_INTMODE	0	GPIO Interrupt Mode 0 = Level triggered 1 = Edge triggered
	0	GP3_DB	0	GPIO de-bounce 0 = GPIO is not debounced 1 = GPIO is debounced
R119 (77h) GPIO Control 4	13:8	GP4_FN [5:0]	00_0010	GPIO 4 Pin Function select 00h = GPIO output 01h = Reserved 02h = IRQ output 03h = GPIO input 04h = Reserved 05h = Reserved 06h = Reserved 07h = DMIC_LR Clock output 08h = FLL Lock output 09h = FLL Clock output 0Ah to 3Fh = Reserved
	7	GP4_DIR	0	GPIO Pin Direction 0 = Output 1 = Input
	6	GP4_OP_CFG	0	Output pin configuration 0 = CMOS 1 = Open-drain
	5	GP4_IP_CFG	1	Input pin configuration 0 = Active low 1 = Active high
	4	GP4_LVL	0	GPIO Output Level (when GP4_FN = 00000) 0 = Logic 0 1 = Logic 1
	3	GP4_PD	0	GPIO Pull-Down Enable 0 = Pull-down disabled 1 = Pull-down enabled (Approx 100kΩ)

REGISTER ADDRESS	BIT	LABEL	DEFAULT	DESCRIPTION
	2	GP4_PU	0	GPIO Pull-Up Enable 0 = Pull-up disabled 1 = Pull-up enabled (Approx 100kΩ)
	1	GP4_INTMODE	0	GPIO Interrupt Mode 0 = Level triggered 1 = Edge triggered
	0	GP4_DB	0	GPIO de-bounce 0 = GPIO is not debounced 1 = GPIO is debounced
R120 (78h) GPIO Control 5	13:8	GP5_FN [5:0]	00_0001	GPIO 5 Pin Function select 00h = GPIO output 01h = BCLK 02h = IRQ output 03h = GPIO input 04h = Reserved 05h = Reserved 06h = Reserved 07h = DMIC_LR Clock output 08h = FLL Lock output 09h = FLL Clock output 0Ah to 3Fh = Reserved
	7	GP5_DIR	1	GPIO Pin Direction 0 = Output 1 = Input
	6	GP5_OP_CFG	0	Output pin configuration 0 = CMOS 1 = Open-drain
	5	GP5_IP_CFG	1	Input pin configuration 0 = Active low 1 = Active high
	4	GP5_LVL	0	GPIO Output Level (when GP5_FN = 00000) 0 = Logic 0 1 = Logic 1
	3	GP5_PD	0	GPIO Pull-Down Enable 0 = Pull-down disabled 1 = Pull-down enabled (Approx 100kΩ)
	2	GP5_PU	0	GPIO Pull-Up Enable 0 = Pull-up disabled 1 = Pull-up enabled (Approx 100kΩ)
	1	GP5_INTMODE	0	GPIO Interrupt Mode 0 = Level triggered 1 = Edge triggered
	0	GP5_DB	0	GPIO de-bounce 0 = GPIO is not debounced 1 = GPIO is debounced

Table 64 GPIO Control

## INTERRUPTS

The Interrupt Controller has multiple inputs. These include the GPIO input pins and the Write Sequencer Status. Any combination of these inputs can be used to trigger an Interrupt (IRQ) event.

There is an Interrupt Status field associated with each of the IRQ inputs. These are contained in the Interrupt Status Register (R121), as described in Table 65. The status of the IRQ inputs can be read from this register at any time, or else in response to the Interrupt Output being signalled via a GPIO pin.

The Interrupt Output represents the logical 'OR' of all the unmasked IRQ inputs. The bits within the Interrupt Status register (R121) are latching fields and, once they are set, they are not reset until the Status Register is read. Accordingly, the Interrupt Output is not reset until each of the unmasked IRQ inputs has been read. Note that, if the condition that caused the IRQ input to be asserted is still valid, then the Interrupt Output will remain set even after the Status register has been read.

Each of the IRQ inputs can be individually masked or enabled as an input to the Interrupt function, using the bits contained in the Interrupt Status Mask register (R122). Note that the interrupt status fields remain valid, even when masked, but the masked bits will not cause the Interrupt Output to be asserted.

When a GPIO input is used as Interrupt event, the polarity can be set using GP\_IP\_CFG as described in Table 64. The polarity of the FLL Lock indication can be set using FLL\_LOCK\_INV as described in Table 65; this allows the IRQ event to be used to indicate either the assertion or the de-assertion of the FLL Lock signal.

By default, the Interrupt Output is Active High. The polarity can be inverted using IRQ\_POL.

The Interrupt Output may be configured the INTERRUPT/GPIO4 pin or on the GPIO1/DMIC\_LR, GPIO2/DMIC\_DAT, GPIO3/ADDR or BCLK/GPIO5 pins. Interrupt Output is the default function on the INTERRUPT pin (GP4\_FN = 2h), but the INTERRUPT pin can also be used to support other functions. See "General Purpose Input/Output (GPIO)" for details of how to configure GPIO pins for Interrupt (IRQ) output.

The WM8910 Interrupt Controller circuit is illustrated in Figure 54. The associated control fields are described in Table 65.

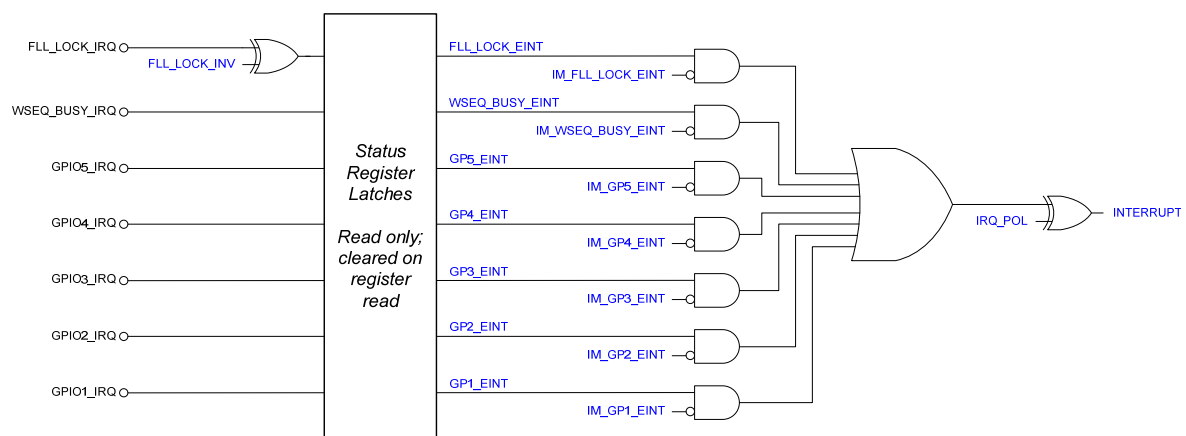

Figure 49 Interrupt Controller

REGISTER ADDRESS	BIT	LABEL	DEFAULT	DESCRIPTION
R121 (79h) Interrupt Status 1	13	WSEQ_BUSY_EINT	0	Write Sequencer Busy IRQ status 0 = WSEQ IRQ not set 1 = WSEQ IRQ set The Write Sequencer asserts this flag when it has completed a programmed sequence - ie it indicates that the Write Sequencer is NOT Busy. (Read-Only Register)
	5	FLL_LOCK_EINT	0	FLL Lock IRQ status 0 = FLL Lock IRQ not set 1 = FLL Lock IRQ set (Read-Only Register)
	4	GP5_EINT	0	GPIO5 IRQ status 0 = GPIO5 IRQ not set 1 = GPIO5 IRQ set (Read-Only Register)
	3	GP4_EINT	0	GPIO4 IRQ status 0 = GPIO4 IRQ not set 1 = GPIO4 IRQ set (Read-Only Register)
	2	GP3_EINT	0	GPIO3/ADDR IRQ status 0 = GPIO3 IRQ not set 1 = GPIO3 IRQ set (Read-Only Register)
	1	GP2_EINT	0	GPIO2/DMIC_DAT IRQ status 0 = GPIO2 IRQ not set 1 = GPIO2 IRQ set (Read-Only Register)
	0	GP1_EINT	0	GPIO1/DMIC_LR IRQ status 0 = GPIO1 IRQ not set 1 = GPIO1 IRQ set (Read-Only Register)
	R122 (7Ah) Interrupt Status 1 Mask	13	IM_WSEQ_BUSY_EINT	1
5		IM_FLL_LOCK_EINT	1	Interrupt mask for FLL Lock 0 = Not masked 1 = Masked
4		IM_GP5_EINT	1	Interrupt mask for GPIO5 0 = Not masked 1 = Masked
3		IM_GP4_EINT	1	Interrupt mask for GPIO4 0 = Not masked 1 = Masked
2		IM_GP3_EINT	1	Interrupt mask for GPIO3/ADDR 0 = Not masked 1 = Masked
1		IM_GP2_EINT	1	Interrupt mask for GPIO2/DMIC_DAT 0 = Not masked 1 = Masked
0		IM_GP1_EINT	1	Interrupt mask for GPIO1/DMIC_LR 0 = Not masked 1 = Masked

REGISTER ADDRESS	BIT	LABEL	DEFAULT	DESCRIPTION
R123 (7Bh) Interrupt Polarity 1	5	FLL_LOCK_INV	0	FLL Lock polarity 0 = Non-inverted 1 = Inverted
R126 (7Eh) Interrupt Control	0	IRQ_POL	0	Interrupt Output polarity 0 = Active high 1 = Active low

Table 65 Interrupt Control

## CONTROL INTERFACE

The WM8910 is controlled by writing to registers through a 2-wire serial control interface. Readback is available for all registers, including Chip ID, power management status and GPIO status.

Note that, if it cannot be assured that MCLK is present when accessing the register map, then it is required to set CLK\_SYS\_ENA = 0 to ensure correct operation. See "Clocking and Sample Rates" for further details and for the definition of CLK\_SYS\_ENA.

The WM8910 is a slave device on the control interface; SCLK is a clock input, while SDIN is a bi-directional data pin. To allow arbitration of multiple slaves (and/or multiple masters) on the same interface, the WM8910 transmits logic 1 by tri-stating the SDIN pin, rather than pulling it high. An external pull-up resistor is required to pull the SDIN line high so that the logic 1 can be recognised by the master.

In order to allow many devices to share a single 2-wire control bus, every device on the bus has a unique 8-bit device ID (this is not the same as the 8-bit address of each register in the WM8910). The default device ID for the WM8910 is 0011 0100 (34h). The LSB of the device ID is the Read/Write bit; this bit is set to logic 1 for "Read" and logic 0 for "Write".

Alternatively, the device ID can be set to 0011 0110 (0x36) by pulling the GPIO3/ADDR pin high during device start-up, when the internal power-on reset signal PORB (see "Power-on Reset") is released. The setup and hold times for device ID selection are shown in Table 66. After the device ID has been selected, the GPIO3/ADDR pin can be used as a GPIO.

SYMBOL	MIN	TYP	MAX	UNIT
$T_{psetup}$	100			$\mu$ s
$T_{p\text{hold}}$	100			$\mu$ s

Table 66 GPIO3/ADDR Latch on Power-up Timing

The WM8910 operates as a slave device only. The controller indicates the start of data transfer with a high to low transition on SDIN while SCLK remains high. This indicates that a device ID, register address and data will follow. The WM8910 responds to the start condition and shifts in the next eight bits on SDIN (8-bit device ID, including Read/Write bit, MSB first). If the device ID received matches the device ID of the WM8910, then the WM8910 responds by pulling SDIN low on the next clock pulse (ACK). If the device ID is not recognised or the R/W bit is '1' when operating in write only mode, the WM8910 returns to the idle condition and waits for a new start condition and valid address.

If the device ID matches the device ID of the WM8910, the data transfer continues as described below. The controller indicates the end of data transfer with a low to high transition on SDIN while SCLK remains high. After receiving a complete address and data sequence the WM8910 returns to the idle state and waits for another start condition. If a start or stop condition is detected out of sequence at any point during data transfer (i.e. SDIN changes while SCLK is high), the device returns to the idle condition.

The WM8910 supports the following read and write operations:

- Single write
- Single read
- Multiple write using auto-increment
- Multiple read using auto-increment

The sequence of signals associated with a single register write operation is illustrated in Figure 50.

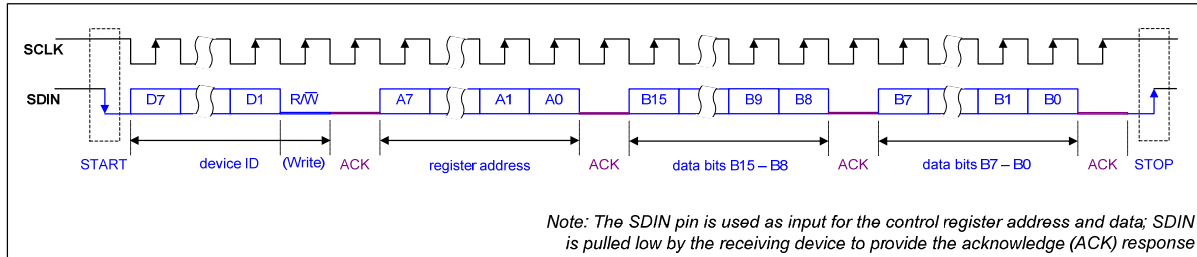

Figure 50 Control Interface Register Write

The sequence of signals associated with a single register read operation is illustrated in Figure 51.

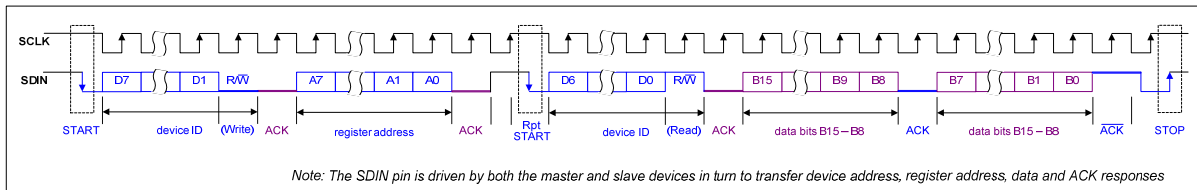

Figure 51 Control Interface Register Read

The Control Interface also supports other register operations, as listed above. The interface protocol for these operations is summarised below. The terminology used in the following figures is detailed in Table 67.

Note that multiple write and multiple read operations are supported using the auto-increment mode. This feature enables the host processor to access sequential blocks of the data in the WM8910 register map faster than is possible with single register operations.

TERMINOLOGY	DESCRIPTION	
S	Start Condition	
Sr	Repeated start	
A	Acknowledge (SDIN Low)	
$\bar{A}$	Not Acknowledge (SDIN High)	
P	Stop Condition	
R/W	ReadNotWrite	0 = Write 1 = Read
[White field]	Data flow from bus master to WM8910	
[Grey field]	Data flow from WM8910 to bus master	

Table 67 Control Interface Terminology

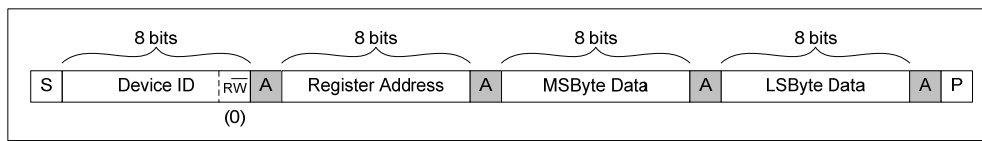

Figure 52 Single Register Write to Specified Address

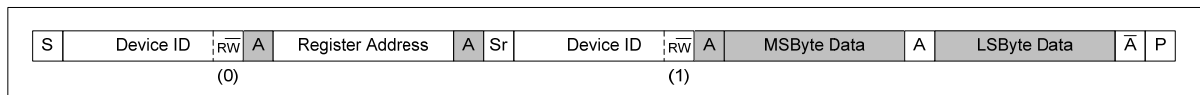

Figure 53 Single Register Read from Specified Address

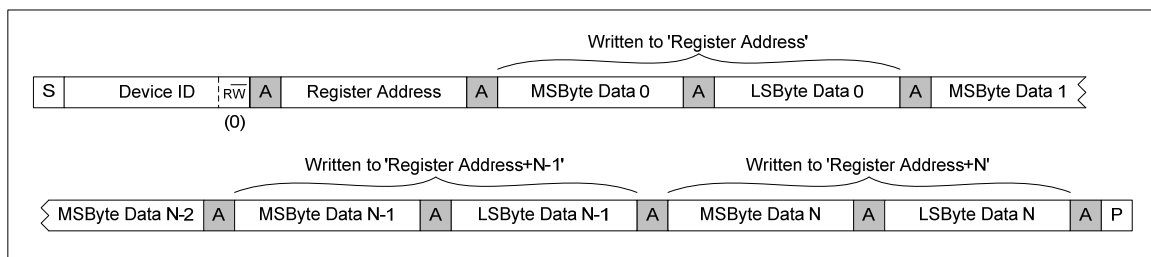

Figure 54 Multiple Register Write to Specified Address using Auto-increment

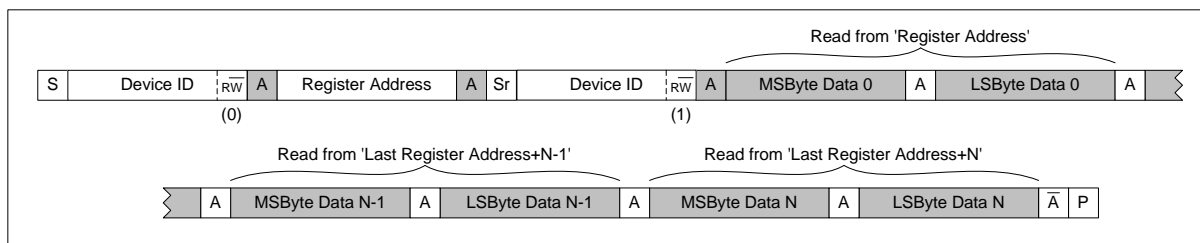

Figure 55 Multiple Register Read from Specified Address using Auto-increment

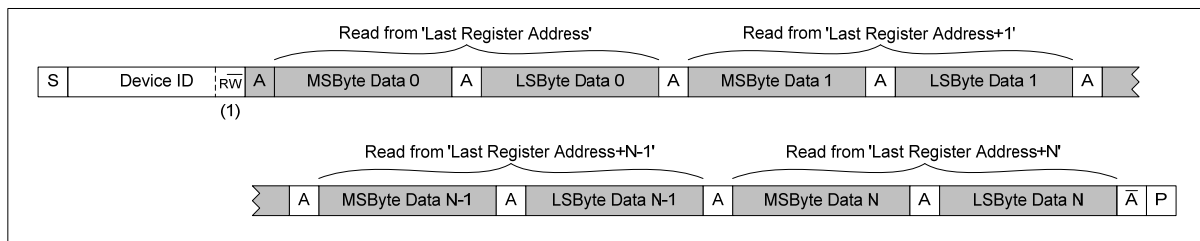

Figure 56 Multiple Register Read from Last Address using Auto-increment

## CONTROL WRITE SEQUENCER

The Control Write Sequencer is a programmable unit that forms part of the WM8910 control interface logic. It provides the ability to perform a sequence of register write operations with the minimum of demands on the host processor - the sequence may be initiated by a single operation from the host processor and then left to execute independently.

Default sequences for Start-Up and Shut-Down are provided (see "Default Sequences" section). It is recommended that these default sequences are used unless changes become necessary.

When a sequence is initiated, the sequencer performs a series of pre-defined register writes. The host processor informs the sequencer of the start index of the required sequence within the sequencer's memory. At each step of the sequence, the contents of the selected register fields are read from the sequencer's memory and copied into the WM8910 control registers. This continues sequentially through the sequencer's memory until an "End of Sequence" bit is encountered; at this point, the sequencer stops and an Interrupt status flag is asserted. For cases where the timing of the write sequence is important, a programmable delay can be set for specific steps within the sequence.

Note that the Control Write Sequencer's internal clock is derived from the internal clock CLK\_SYS. An external MCLK signal must be present when using the Control Write Sequencer, and CLK\_SYS must be enabled by setting CLK\_SYS\_ENA (see "Clocking and Sample Rates"). The clock division from MCLK is handled transparently by the WM8910 without user intervention, as long as MCLK and sample rates are set correctly.

### INITIATING A SEQUENCE

The Register fields associated with running the Control Write Sequencer are described in Table 68.

The Write Sequencer Clock is enabled by setting the WSMD\_CLK\_ENA bit. Note that the operation of the Control Write Sequencer also requires the internal clock CLK\_SYS to be enabled via the CLK\_SYS\_ENA (see "Clocking and Sample Rates").

The start index of the required sequence must be written to the WSEQ\_START\_INDEX field. Setting the WSEQ\_START bit initiates the sequencer at the given start index.

The Write Sequencer can be interrupted by writing a logic 1 to the WSEQ\_ABORT bit.

The current status of the Write Sequencer can be read using two further register fields - when the WSEQ\_BUSY bit is asserted, this indicates that the Write Sequencer is busy. Note that, whilst the Control Write Sequencer is running a sequence (indicated by the WSEQ\_BUSY bit), normal read/write operations to the Control Registers cannot be supported. (The Write Sequencer registers and the Software Reset register can still be accessed when the Sequencer is busy.) The index of the current step in the Write Sequencer can be read from the WSEQ\_CURRENT\_INDEX field; this is an indicator of the sequencer's progress. On completion of a sequence, this field holds the index of the last step within the last commanded sequence.

When the Write Sequencer reaches the end of a sequence, it asserts the WSEQ\_BUSY\_EINT flag in Register R121 (see Table 65 within the "Interrupts" section). This flag can be used to generate an Interrupt Event on completion of the sequence. Note that the WSEQ\_BUSY\_EINT flag is asserted to indicate that the WSEQ is NOT Busy.

REGISTER ADDRESS	BIT	LABEL	DEFAULT	DESCRIPTION
R108 (6Ch) Write Sequencer 0	8	WSMD_CLK_EN A	0	Write Sequencer Clock Enable 0 = Disabled 1 = Enabled
R111 (6Fh) Write Sequencer 3	9	WSEQ_ABORT	0	Writing a 1 to this bit aborts the current sequence and returns control of the device back to the serial control interface. (Write-Only Register)
	8	WSEQ_START	0	Writing a 1 to this bit starts the write sequencer at the memory location indicated by the WSEQ_START_INDEX field. The sequence continues until it reaches an "End of sequence" flag. At the end of the sequence, this bit will be reset by the Write Sequencer. (Write-Only Register)
	5:0	WSEQ_START_INDEX [5:0]	00_0000	Sequence Start Index. This is the memory location of the first command in the selected sequence. 0 to 31 = RAM addresses 32 to 48 = ROM addresses 49 to 63 = Reserved
R112 (70h) Write Sequencer 4	9:4	WSEQ_CURRENT_INDEX [5:0]	00_0000	Sequence Current Index. This is the location of the most recently accessed command in the write sequencer memory.
	0	WSEQ_BUSY	0	Sequencer Busy flag 0 = Sequencer idle 1 = Sequencer busy Note: it is not possible to write to control registers via the control interface while the Sequencer is Busy. (Read-Only Register)

Table 68 Write Sequencer Control – Initiating a Sequence

### PROGRAMMING A SEQUENCE

A sequence consists of write operations to data bits (or groups of bits) within the control registers. The Register fields associated with programming the Control Write Sequencer are described in Table 69.

For each step of the sequence being programmed, the Sequencer Index must be written to the WSEQ\_WRITE\_INDEX field. The values 0 to 31 correspond to all the available RAM addresses within the Write Sequencer memory. (Note that memory addresses 32 to 48 also exist, but these are ROM addresses, which are not programmable.)

Having set the Index as described above, Register R109 must be written to (containing the Control Register Address, the Start Bit Position and the Field Width applicable to this step of the sequence). Also, Register R110 must be written to (containing the Register Data, the End of Sequence flag and the Delay time required after this step is executed). After writing to these two registers, the next step in the sequence may be programmed by updating WSEQ\_WRITE\_INDEX and repeating the procedure.

WSEQ\_ADDR is an 8-bit field containing the Control Register Address in which the data should be written.

WSEQ\_DATA\_START is a 4-bit field which identifies the LSB position within the selected Control Register to which the data should be written. Setting WSEQ\_DATA\_START = 0100 will cause 1-bit data to be written to bit 4. With this setting, 4-bit data would be written to bits 7:4 and so on.

WSEQ\_DATA\_WIDTH is a 3-bit field which identifies the width of the data block to be written. This enables selected portions of a Control Register to be updated without any concern for other bits within the same register, eliminating the need for read-modify-write procedures. Values of 0 to 7 correspond to data widths of 1 to 8 respectively. For example, setting WSEQ\_DATA\_WIDTH = 010 will cause a 3-bit data block to be written. Note that the maximum value of this field corresponds to an 8-bit data block; writing to register fields greater than 8 bits wide must be performed using two separate operations of the Control Write Sequencer.

WSEQ\_DATA is an 8-bit field which contains the data to be written to the selected Control Register. The WSEQ\_DATA\_WIDTH field determines how many of these bits are written to the selected register; the most significant bits (above the number indicated by WSEQ\_DATA\_WIDTH) are ignored.

WSEQ\_DELAY is a 4-bit field which controls the waiting time between the current step and the next step in the sequence. The total delay time per step (including execution) is given by:

$$T = k \times (2^{WSEQ\_DELAY} + 8)$$

where  $k = 62.5\mu\text{s}$  (under recommended operating conditions)

This gives a useful range of execution/delay times from  $562\mu\text{s}$  up to 2.048s per step.

WSEQ\_EOS is a 1-bit field which indicates the End of Sequence. If this bit is set, then the Control Write Sequencer will automatically stop after this step has been executed.

REGISTER ADDRESS	BIT	LABEL	DEFAULT	DESCRIPTION
R108 (6Ch) Write Sequencer 0	4:0	WSEQ_WRIT E_INDEX [4:0]	0_0000	Sequence Write Index. This is the memory location to which any updates to R109 and R110 will be copied. 0 to 31 = RAM addresses
R109 (6Dh) Write Sequencer 1	14:12	WSEQ_DATA _WIDTH [2:0]	000	Width of the data block written in this sequence step. 000 = 1 bit 001 = 2 bits 010 = 3 bits 011 = 4 bits 100 = 5 bits 101 = 6 bits 110 = 7 bits 111 = 8 bits
	11:8	WSEQ_DATA _START [3:0]	0000	Bit position of the LSB of the data block written in this sequence step. 0000 = Bit 0 ... 1111 = Bit 15
	7:0	WSEQ_ADDR [7:0]	0000_0000	Control Register Address to be written to in this sequence step.
R110 (6Eh) Write Sequencer 2	14	WSEQ_EOS	0	End of Sequence flag. This bit indicates whether the Control Write Sequencer should stop after executing this step. 0 = Not end of sequence 1 = End of sequence (Stop the sequencer after this step).
	11:8	WSEQ_DELA Y [3:0]	0000	Time delay after executing this step. Total time per step (including execution) = $62.5\mu\text{s} \times (2^{WSEQ\_DELAY} + 8)$

REGISTER ADDRESS	BIT	LABEL	DEFAULT	DESCRIPTION
	7:0	WSEQ_DATA [7:0]	0000_0000	Data to be written in this sequence step. When the data width is less than 8 bits, then one or more of the MSBs of WSEQ_DATA are ignored. It is recommended that unused bits be set to 0.

Table 69 Write Sequencer Control - Programming a Sequence

Note that a 'Dummy' write can be inserted into a control sequence by commanding the sequencer to write a value of 0 to bit 0 of Register R255 (FFh). This is effectively a write to a non-existent register location. This can be used in order to create placeholders ready for easy adaptation of the sequence. For example, a sequence could be defined to power-up a mono signal path from DACL to headphone, with a 'dummy' write included to leave space for easy modification to a stereo signal path configuration. Dummy writes can also be used in order to implement additional time delays between register writes. Dummy writes are included in the default start-up sequence – see Table 71.

In summary, the Control Register to be written is set by the WSEQ\_ADDR field. The data bits that are written are determined by a combination of WSEQ\_DATA\_START, WSEQ\_DATA\_WIDTH and WSEQ\_DATA. This is illustrated below for an example case of writing to the VMID\_RES field within Register R5 (05h).

In this example, the Start Position is bit 01 (WSEQ\_DATA\_START = 0001b) and the Data width is 2 bits (WSEQ\_DATA\_WIDTH = 0001b). With these settings, the Control Write Sequencer would update the Control Register R5 [2:1] with the contents of WSEQ\_DATA [1:0].

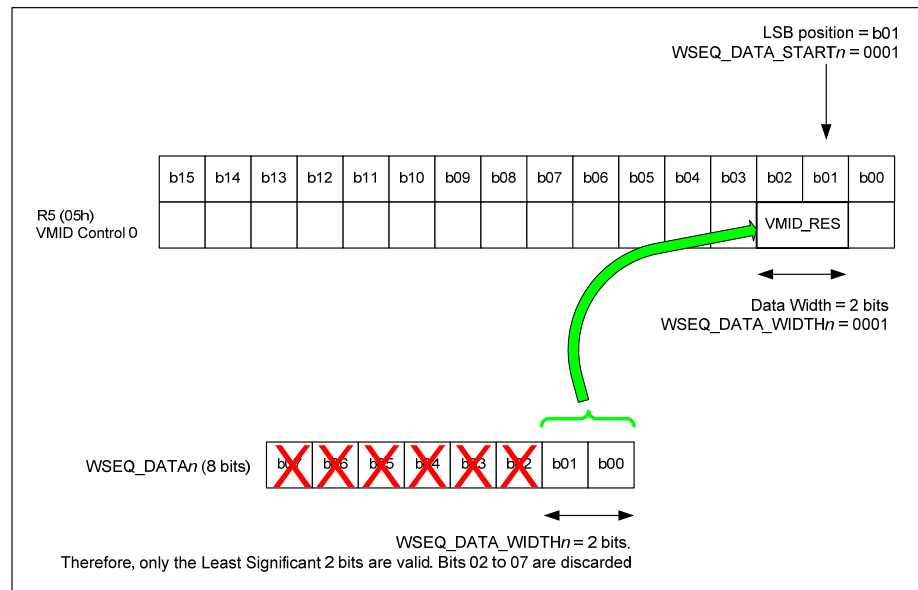

Figure 57 Control Write Sequencer Example

### DEFAULT SEQUENCES

When the WM8910 is powered up, two Control Write Sequences are available through default settings in both RAM and ROM memory locations. The purpose of these sequences, and the register write required to initiate them, is summarised in Table 70. In both cases, a single register write will initiate the sequence.

WSEQ START INDEX	WSEQ FINISH INDEX	PURPOSE	TO INITIATE
0 (00h)	29 (1Dh)	Start-Up sequence	Write 0100h to Register R111 (6Fh)
32 (20h)	48 (30h)	Shutdown sequence	Write 0120h to Register R111 (6Fh)

**Table 70 Write Sequencer Default Sequences**

Note on Shut-Down sequence: The instruction at Index Address 32 (20h) shorts the outputs LINEOUTL and LINEOUTR. If the Line outputs are not in use at the time the sequence is run, then the sequence could, instead, be started at Index Address 33.

Index addresses 0 to 31 may be programmed to users' own settings at any time, as described in "Programming a Sequence" Users' own settings remain in memory and are not affected by software resets (i.e. writing to Register R0). However, any non-default sequences are lost when the device is powered down.

### START-UP SEQUENCE

The Start-up sequence is initiated by writing 0100h to Register R111 (6Fh). This single operation starts the Control Write Sequencer at Index Address 0 (00h) and executes the sequence defined in Table 71.

For typical clocking configurations with MCLK=12.288MHz, this sequence takes approximately 425ms to run.

WSEQ INDEX	REGISTER ADDRESS	WIDTH	START	DATA	DELAY	EOS	DESCRIPTION
0 (00h)	R4 (04h)	5 bits	Bit 0	1Ah	0h	0b	POBCTRL = 1 ISEL [1:0] = 10b STARTUP_BIAS_ENA = 1 BIAS_ENA = 0 (delay = 0.5625ms)
1 (01h)	R65 (41h)	1 bit	Bit 1	01h	9h	0b	SPK_DISCHARGE = 1 (delay = 32.5ms)
2 (02h)	R17 (11h)	2 bits	Bit 0	03h	0h	0b	SPKL_ENA = 1 SPKR_ENA = 1 (delay = 0.5625ms)
3 (03h)	R65 (41h)	1 bit	Bit 1	00h	0h	0b	SPK_DISCHARGE = 0 (delay = 0.5625ms)
4 (04h)	R5 (5h)	8 bits	Bit 0	F7h	Bh	0b	VMID_TIE_ENA = 1 BUFIO_ENA = 1 VMID_IO_ENA = 1 VMID_SOFT = 10 VMID_RES = 11 VMID_BUF_ENA = 1 (delay = 128.5ms)
5 (05h)	R17 (11h)	2 bits	Bit 0	00h	0h	0b	SPKL_ENA = 0 SPKR_ENA = 0 (delay = 0.5625ms)

WSEQ INDEX	REGISTER ADDRESS	WIDTH	START	DATA	DELAY	EOS	DESCRIPTION
6 (06h)	R5 (5h)	2 bits	Bit 3	00h	0h	0b	VMID_SOFT = 00 (delay = 0.5625ms)
7 (07h)	R5 (05h)	2 bits	Bit 1	01h	0h	0b	VMID_RES [1:0] = 01b (delay = 0.5625ms)
8 (08h)	R4 (04h)	1 bit	Bit 0	01h	0h	0b	BIAS_ENA = 1 (delay = 0.5625ms)
9 (09h)	R14 (0Eh)	2 bits	Bit 0	03h	0h	0b	HPL_PGA_ENA = 1 HPR_PGA_ENA = 1 (delay = 0.5625ms)
10 (0Ah)	R13 (Dh)	2 bits	Bit 0	03h	0h	0b	MIXOUTL = 1 MIXOUTR = 1 (delay = 0.5625ms)
11 (0Bh)	R15 (0Fh)	2 bits	Bit 0	03h	0h	0b	LINEOUTL_PGA_ENA = 1 LINEOUTR_PGA_ENA = 1 (delay = 0.5625ms)
12 (0Ch)	R22 (16h)	1 bit	Bit 1	01h	0h	0b	CLK_DSP_ENA = 1 (delay = 0.5625ms)
13 (0Dh)	R18 (12h)	2 bits	Bit 2	03h	5h	0b	DAACL_ENA = 1 DACR_ENA = 1 (delay = 2.5ms)
14 (0Eh)	R255 (FFh)	1 bit	Bit 0	00h	0h	0b	Dummy Write for expansion (delay = 0.5625ms)
15 (0Fh)	R4 (04h)	1 bit	Bit 4	00h	0h	0b	POBCTRL = 0 (delay = 0.5625ms)
16 (10h)	R98 (62h)	1 bit	Bit 0	01h	6h	0b	CP_ENA = 1 (delay = 4.5ms)
17 (11h)	R255 (FFh)	1 bit	Bit 0	00h	0h	0b	Dummy Write for expansion (delay = 0.5625ms)
18 (12h)	R90 (5Ah)	8 bits	Bit 0	11h	0h	0b	HPL_ENA = 1 HPR_ENA = 1 (delay = 0.5625ms)
19 (13h)	R94 (5Eh)	8 bits	Bit 0	11h	0h	0b	LINEOUTL_ENA = 1 LINEOUTR_ENA = 1 (delay = 0.5625ms)
20 (14h)	R90 (5Ah)	8 bits	Bit 0	33h	0h	0b	HPL_ENA_DLY = 1 HPR_ENA_DLY = 1 (delay = 0.5625ms)
21 (15h)	R94 (5Eh)	8 bits	Bit 0	33h	0h	0b	LINEOUTL_ENA_DLY = 1 LINEOUTR_ENA_DLY = 1 (delay = 0.5625ms)
22 (16h)	R69 (45h)	2 bits	Bit 0	02h	0h	0b	DCS_MODE = 10 (delay = 0.5625ms)
23 (17h)	R67 (43h)	4 bits	Bit 0	0Fh	Ch	0b	DCS_ENA = 1111 (delay = 256.5ms)
24 (18h)	R67 (43h)	4 bits	Bit 0	0Fh	7h	0b	DCS_ENA = 1111 (delay = 8.5ms)
25 (19h)	R255 (FFh)	1 bit	Bit 0	00h	0h	0b	Dummy Write for expansion (delay = 0.5625ms)
26 (1Ah)	R90 (5Ah)	8 bits	Bit 0	77h	0h	0b	HPL_ENA_OUTP = 1 HPR_ENA_OUTP = 1 (delay = 0.5625ms)

WSEQ INDEX	REGISTER ADDRESS	WIDTH	START	DATA	DELAY	EOS	DESCRIPTION
27 (1Bh)	R94 (5Eh)	8 bits	Bit 0	77h	0h	0b	LINEOUTL_ENA_OUTP = 1 LINEOUTR_ENA_OUTP = 1 (delay = 0.5625ms)
28 (1Ch)	R90 (5Ah)	8 bits	Bit 0	FFh	0h	0b	HPL_RMV_SHORT = 1 HPR_RMV_SHORT = 1 (delay = 0.5625ms)
29 (1Dh)	R94 (5Eh)	8 bits	Bit 0	FFh	0h	1b	LINEOUTL_RMV_SHORT = 1 LINEOUTR_RMV_SHORT = 1 End of Sequence
30 (1Eh)	R255 (FFh)	1 bit	Bit 0	00h	0h	0b	Spare
31 (1Fh)	R255 (FFh)	1 bit	Bit 0	00h	0h	0b	Spare

Table 71 Start-up Sequence

**SHUTDOWN SEQUENCE**

The Shutdown sequence is initiated by writing 0120h to Register R111 (6Fh). This single operation starts the Control Write Sequencer at Index Address 32 (20h) and executes the sequence defined in Table 72.

For typical clocking configurations with MCLK=12.288MHz, this sequence takes approximately 325ms to run.

WSEQ INDEX	REGISTER ADDRESS	WIDTH	START	DATA	DELAY	EOS	DESCRIPTION
32 (20h)	R94 (5Eh)	8 bits	Bit 0	77h	0h	0b	LINEOUTL_RMV_SHORT = 0 LINEOUTR_RMV_SHORT = 0 (delay = 0.5625ms)
33 (21h)	R90 (5Ah)	8 bits	Bit 0	77h	0h	0b	HPL_RMV_SHORT = 0 HPR_RMV_SHORT = 0 (delay = 0.5625ms)
34 (22h)	R90 (5Ah)	8 bits	Bit 0	00h	0h	0b	HPL_ENA_OUTP = 0 HPL_ENA_DLY = 0 HPL_ENA = 0 HPR_ENA_OUTP = 0 HPR_ENA_DLY = 0 HPR_ENA = 0 (delay = 0.5625ms)
35 (23h)	R94 (5Eh)	8 bits	Bit 0	00h	0h	0b	LINEOUTL_ENA_OUTP = 0 LINEOUTL_ENA_DLY = 0 LINEOUTL_ENA = 0 LINEOUTR_ENA_OUTP = 0 LINEOUTR_ENA_DLY = 0 LINEOUTR_ENA = 0 (delay = 0.5625ms)
36 (24h)	R67 (43h)	4 bits	Bit 0	00h	0h	0b	DCS_ENA = 0000 (delay = 0.5625ms)
37 (25h)	R98 (62h)	1 bit	Bit 0	00h	0h	0b	CP_ENA = 0 (delay = 0.5625ms)
38 (26h)	R18 (12h)	2 bits	Bit 2	00h	0h	0b	DACL_ENA = 0 DACR_ENA = 0 (delay = 0.5625ms)
39 (27h)	R22 (16h)	1 bit	Bit 1	00h	0h	0b	CLK_DSP_ENA = 0 (delay = 0.5625ms)
40 (28h)	R14 (0Eh)	2 bits	Bit 0	00h	0h	0b	HPL_PGA_ENA = 0 HPR_PGA_ENA = 0 (delay = 0.5625ms)
41 (29h)	R15 (0Fh)	2 bits	Bit 0	00h	0h	0b	LINEOUTL_PGA_ENA = 0 LINEOUTR_PGA_ENA = 0 (delay = 0.5625ms)
42 (2Ah)	R13 (0Dh)	2 bits	Bit 0	00h	0h	0b	MIXOUTL_ENA = 0 MIXOUTR_ENA = 0 (delay = 0.5625ms)
43 (2Bh)	R4 (04h)	1 bit	Bit 0	00h	0h	0b	BIAS_ENA = 0 (delay = 0.5625ms)
44 (2Ch)	R5 (05h)	2 bits	Bit 3	02h	0h	0b	VMID_SOFT = 10 (delay = 0.5625ms)
45 (2Dh)	R5 (05h)	1 bit	Bit 0	00h	Ch	0b	VMID_BUF_ENA = 0 (delay = 256.5ms)

WSEQ INDEX	REGISTER ADDRESS	WIDTH	START	DATA	DELAY	EOS	DESCRIPTION
46 (2Eh)	R5 (05h)	1 bit	Bit 0	00h	9h	0b	VMID_BUF_ENA = 0 (delay = 32.5ms)
47 (2Fh)	R5 (05h)	8 bits	Bit 0	00h	0h	0b	VMID_TIE_ENA = 0 BUFIO_ENA = 0 VMID_IO_ENA = 0 VMID_SOFT = 00 VMID_RES = 00 VMID_BUF_ENA = 0 (delay = 0.5625ms)
48 (30h)	R4 (04h)	2 bits	Bit 0	00h	0h	1b	STARTUP_BIAS_ENA = 0 BIAS_ENA = 0 End of Sequence

Table 72 Shutdown Sequence

**POWER-ON RESET**

The WM8910 includes an internal Power-On-Reset (POR) circuit, which is used to reset the digital logic into a default state after power up. The POR circuit is powered from AVDD and monitors DCVDD. The internal  $\overline{\text{POR}}$  signal is asserted low when AVDD or DCVDD are below minimum thresholds.

The specific behaviour of the circuit will vary, depending on the relative timing of the supply voltages. Typical scenarios are illustrated in Figure 58 and Figure 59.

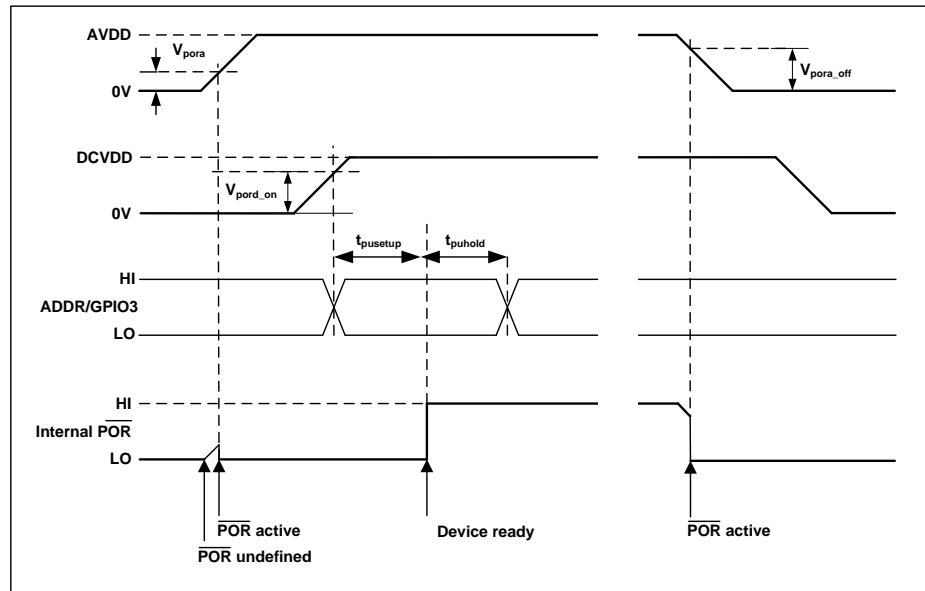

Figure 58 Power On Reset Timing - AVDD enabled first

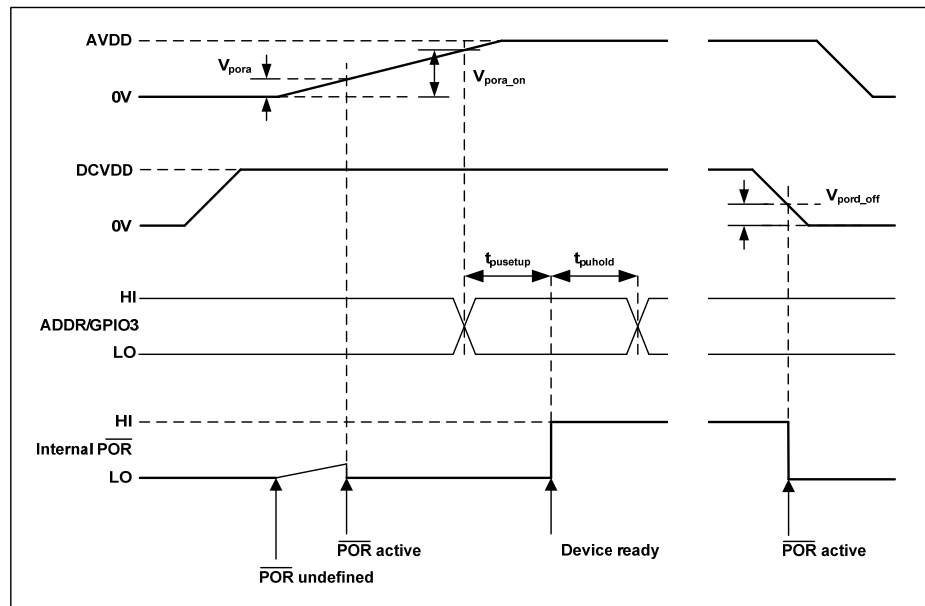

Figure 59 Power On Reset Timing - DCVDD enabled first

The  $\overline{\text{POR}}$  signal is undefined until AVDD has exceeded the minimum threshold,  $V_{\text{pora}}$ . Once this threshold has been exceeded,  $\overline{\text{POR}}$  is asserted low and the chip is held in reset. In this condition, all writes to the control interface are ignored. Once AVDD and DCVDD have reached their respective power on thresholds,  $\overline{\text{POR}}$  is released high, all registers are in their default state, and writes to the control interface may take place.

Note that a minimum power-on reset period,  $T_{\text{POR}}$ , applies even if AVDD and DCVDD have zero rise time. (This specification is guaranteed by design rather than test.)

On power down,  $\overline{\text{POR}}$  is asserted low when any of AVDD or DCVDD falls below their respective power-down thresholds.

Typical Power-On Reset parameters for the WM8910 are defined in Table 73.

SYMBOL	DESCRIPTION	TYP	UNIT
$V_{\text{pora}}$	AVDD threshold below which POR is undefined	0.5	V
$V_{\text{pora\_on}}$	Power-On threshold (AVDD)	1.15	V
$V_{\text{pora\_off}}$	Power-Off threshold (AVDD)	1.12	V
$V_{\text{pord\_on}}$	Power-On threshold (DCVDD)	0.57	V
$V_{\text{pord\_off}}$	Power-Off threshold (DCVDD)	0.56	V
$T_{\text{POR}}$	Minimum Power-On Reset period	10.6	$\mu\text{s}$

**Table 73 Typical Power-On Reset parameters**

**Notes:**

1. If AVDD and DCVDD suffer a brown-out (i.e. drop below the minimum recommended operating level but do not go below  $V_{\text{pora\_off}}$  or  $V_{\text{pord\_off}}$ ) then the chip does not reset and resumes normal operation when the voltage is back to the recommended level again.
2. The chip enters reset at power down when AVDD or DCVDD falls below  $V_{\text{pora\_off}}$  or  $V_{\text{pord\_off}}$ . This may be important if the supply is turned on and off frequently by a power management system.
3. The minimum  $t_{\text{por}}$  period is maintained even if DCVDD and AVDD have zero rise time. This specification is guaranteed by design rather than test.
4. See "Control Interface" section for details of  $t_{\text{pusetup}}$  and  $t_{\text{puhold}}$ .

## QUICK START-UP AND SHUTDOWN

The WM8910 has the capability to perform a quick start-up and shut-down with a minimum number of register operations. This is achieved using the Control Write Sequencer, which is configured with default start-up settings that set up the device for DAC playback via Headphone and Line Output. Assuming a 12.288MHz external clock, the start-up sequence configures the device for 48kHz playback mode.

The default start-up sequence requires three register write operations. The default shutdown sequence requires just a single register write. The minimum procedure for executing the quick start-up and shutdown sequences is described below. See "Control Write Sequencer" for more details.

### QUICK START-UP (DEFAULT SEQUENCE)

An external clock must be applied to MCLK. Assuming 12.288MHz input clock, the start-up sequence will take approximately 425ms to complete.

The following register operations will initiate the quick start-up sequence.

REGISTER ADDRESS	VALUE	DESCRIPTION
R108 (6Ch) Write Sequencer 0	0100h	WSMD_CLK_ENA = 1 This enables the Write Sequencer Clock
R22 (16h) Clock Rates 2	0004h	CLK_SYS_ENA = 1 This enables the System Clock
R111 (6Fh) Write Sequencer 3	0100h	WSEQ_START_INDEX = 00h WSEQ_START = 1 WSEQ_ABORT = 0 This starts the Write Sequencer at Index address 0 (00h)

**Table 74 Quick Start-Up Control**

The WSEQ\_BUSY bit (in Register R112, see Table 68) will be set to 1 while the sequence runs. When this bit returns to 0, the device has been set up and is ready for DAC playback operation.

### QUICK SHUTDOWN (DEFAULT SEQUENCE)

The default shutdown sequence assumes the initial device conditions are as configured by the default start-up sequence. Assuming 12.288MHz input clock, the shutdown sequence will take approximately 325ms to complete.

The following register operation will initiate the default shut-down sequence.

REGISTER ADDRESS	VALUE	DESCRIPTION
R111 (6Fh) Write Sequencer 3	0120h	WSEQ_START_INDEX = 20h WSEQ_START = 1 WSEQ_ABORT = 0 This starts the Write Sequencer at Index address 32 (20h)

**Table 75 Quick Shutdown Control**

The WSEQ\_BUSY bit (in Register R112, see Table 68) will be set to 1 while the sequence runs. When this bit returns to 0, the system clock can be disabled (CLK\_SYS\_ENA=0) and MCLK can be stopped.

## SOFTWARE RESET AND CHIP ID

A Software Reset can be commanded by writing to Register R0. This is a read-only register field and the contents will not be affected by writing to this Register.

The Chip ID can be read back from Register R0. The Chip Revision ID can be read back from Register 1, as described in Table 76.

REGISTER ADDRESS	BIT	LABEL	DEFAULT	DESCRIPTION
R0 (00h) SW Reset and ID	15:0	SW_RST_DE C_ID1 [15:0]	8903h	Writing to this register resets all registers to their default state. Reading from this register will indicate Device ID 8903h.
R1 (01h) Revision Number	3:0	CHIP_REV [3:0]	0010b	Reading from this register will indicate the Revision ID. (Read-Only Register)

**Table 76 Software Reset and Chip ID**

## REGISTER MAP

Dec Addr	Hex Addr	Name	15	14	13	12	11	10	9	8	7	6	5	4	3	2	1	0	Bin Default		
0	00	SW Reset and ID	SW_RST_DEV_ID[1:15:0]																1000_1001_0000_0011		
1	01	Revision Number	0	0	0	0	0	0	0	0	0	0	0	0	CHIP_REV[3:0]				0000_0000_0000_0000		
4	04	Bias Control 0	0	0	0	0	0	0	0	0	0	0	0	POBCTRL	ISEL[1:0]		STARTUP_BIAS_ENA	BIAS_ENA	0000_0000_0001_1000		
5	05	VMD Control 0	0	0	0	0	0	0	0	0	VMD_TIE_ENA	BUFO_ENA	VMD_IO_ENA	VMD_SOFT[1:0]		VMD_RES[1:0]		VMD_BUF_ENA	0000_0000_0000_0000		
8	08	Analogue DAC 0	0	0	0	0	0	0	0	0	0	0	DAC_BIAS_BOOST	DACBIAS_SEL[1:0]		DACVMD_BIAS_SEL[1:0]		1	0000_0000_0000_0001		
12	0C	Power Management 0	0	0	0	0	0	0	0	0	0	0	0	0	0	0	INL_ENA	INR_ENA	0000_0000_0000_0000		
13	0D	Power Management 1	0	0	0	0	0	0	0	0	0	0	0	0	0	0	MIXOUTL_ENA	MIXOUTR_ENA	0000_0000_0000_0000		
14	0E	Power Management 2	0	0	0	0	0	0	0	0	0	0	0	0	0	0	HPL_PGA_ENA	HPR_PGA_ENA	0000_0000_0000_0000		
15	0F	Power Management 3	0	0	0	0	0	0	0	0	0	0	0	0	0	0	LINEOUTL_PGA_ENA	LINEOUTR_PGA_ENA	0000_0000_0000_0000		
16	10	Power Management 4	0	0	0	0	0	0	0	0	0	0	0	0	0	0	MIXSPKL_ENA	MIXSPKR_ENA	0000_0000_0000_0000		
17	11	Power Management 5	0	0	0	0	0	0	0	0	0	0	0	0	0	0	SPKL_ENA	SPKR_ENA	0000_0000_0000_0000		
18	12	Power Management 6	0	0	0	0	0	0	0	0	0	0	0	0	0	0	DACL_ENA	DACR_ENA	DMICL_ENA	DMICR_ENA	0000_0000_0000_0000
20	14	Clock Rates 0	0	0	0	0	0	0	1	0	0	0	0	0	0	0	0	MCLKDIV2	0000_0100_0000_0000		
21	15	Clock Rates 1	CLK_SRC_SEL	0	CLK_SYS_RATE[3:0]			CLK_SYS_MODE[1:0]			0	0	0	0	SAMPLE_RATE[3:0]				0000_1100_0000_1000		
22	16	Clock Rates 2	0	0	0	0	0	0	0	0	0	0	0	0	0	0	CLK_SYS_ENA	CLK_DSP_ENA	TO_ENA	0000_0000_0000_0000	
24	18	Audio Interface 0	0	0	0	DACL_DATINV	DACR_DATINV	DAC_BOOST[1:0]		LOOPBACK	AIFTXL_SRC	AIFXR_SRC	AIFDACL_SRC	AIFDACR_SRC	DMIC_COMP	DMIC_COMPMODE	DAC_COMP	DAC_COMPMODE	0000_0000_0101_0000		
25	19	Audio Interface 1	0	0	AIFDAC_TDM	AIFDAC_TDM_CHAN	AIFTX_TDM	AIFTX_TDM_CHAN	LRCLK_DIR	0	AIF_BCLK_INV	BCLK_DIR	0	AIF_LRCLK_INV	AIF_VL[1:0]		AIF_FMT[1:0]		0000_0000_0000_0010		
26	1A	Audio Interface 2	0	0	0	0	0	0	0	0	0	0	0	BCLK_DIV[4:0]				0000_0000_0000_1000			
27	1B	Audio Interface 3	0	0	0	0	0	LRCLK_RATE[10:0]										0000_0000_0010_0010			
30	1E	DAC Digital Volume Left	0	0	0	0	0	0	0	DACVU	DACL_VOL[7:0]								0000_000P_1100_0000		
31	1F	DAC Digital Volume Right	0	0	0	0	0	0	0	DACVU	DACR_VOL[7:0]								0000_000P_1100_0000		
32	20	DAC Digital 0	0	0	0	0	DMICL_DAC_SVOL[3:0]			DMICR_DAC_SVOL[3:0]			DMIC_TO_DACL[1:0]		DMIC_TO_DACR[1:0]		0000_0000_0000_0000				
33	21	DAC Digital 1	0	0	0	DAC_MONO	DAC_SB_FILT	DAC_MUTERATE	DAC_MUTEMODE	0	0	0	0	0	DAC_MUTE	DEEMPH[1:0]		DAC_OSR	0000_0000_0000_0000		
34	22	RESERVED	0	0	0	0	0	0	0	0	0	0	0	0	0	0	0	0	0000_0000_0000_0000		
35	23	RESERVED	0	0	0	0	0	0	0	0	0	0	0	0	0	0	0	0	0000_0000_0000_0000		
36	24	DMIC Digital Volume Left	0	0	0	0	0	0	0	DMICVU	DMICL_VOL[7:0]								0000_000P_1100_0000		
37	25	DMIC Digital Volume Right	0	0	0	0	0	0	0	DMICVU	DMICR_VOL[7:0]								0000_000P_1100_0000		
38	26	DMIC Digital 0	0	0	0	0	0	0	0	0	0	0	1	0	0	0	TXL_DATINV	TXR_DATINV	0000_0000_0001_0000		
39	27	Digital Microphone 0	0	0	0	0	DIGMIC_SRC_SEL[1:0]		0	0	1	1	1	0	0	0	1	1	0000_0000_0111_0011		



Dec Addr	Hex Addr	Name	15	14	13	12	11	10	9	8	7	6	5	4	3	2	1	0	Bin Default	
90	5A	Analogue HP 0	0	0	0	0	0	0	0	0	HPL_RMV_SHORT	HPL_ENA_OUTP	HPL_ENA_DLY	HPL_ENA	HPR_RMV_SHORT	HPR_ENA_OUTP	HPR_ENA_DLY	HPR_ENA	0000_0000_0000_0000	
94	5E	Analogue Lineout 0	0	0	0	0	0	0	0	0	LINEOUTL_RMV_SHORT	LINEOUTL_ENA_OUTP	LINEOUTL_ENA_DLY	LINEOUTL_ENA	LINEOUTR_RMV_SHORT	LINEOUTR_ENA_OUTP	LINEOUTR_ENA_DLY	LINEOUTR_ENA	0000_0000_0000_0000	
98	62	Charge Pump 0	0	0	0	0	0	0	0	0	0	0	0	0	0	0	0	CP_ENA	0000_0000_0000_0000	
104	68	Class W0	0	0	0	0	0	0	0	0	0	0	0	1	0	0	0	CP_DYN_PWR	0000_0000_0001_0000	
108	6C	Write Sequencer 0	0	0	0	0	0	0	0	WSMD_CLK_ENA	0	0	0	WSEQ_WRITE_INDEX[4:0]					0000_0000_0000_0000	
109	6D	Write Sequencer 1	0	WSEQ_DATA_WIDTH[2:0]			WSEQ_DATA_START[3:0]			WSEQ_ADDR[7:0]										0000_0000_0000_0000
110	6E	Write Sequencer 2	0	WSEQ_EOS	0	0	WSEQ_DELAY[3:0]			WSEQ_DATA[7:0]										0000_0000_0000_0000
111	6F	Write Sequencer 3	0	0	0	0	0	0	WSEQ_ABORT	WSEQ_START	0	0	WSEQ_START_INDEX[5:0]						0000_0000_0000_0000	
112	70	Write Sequencer 4	0	0	0	0	0	0	WSEQ_CURRENT_INDEX[5:0]					0	0	0	0	WSEQ_BUSY	0000_0000_0000_0000	
116	74	GPIO Control 1	0	0	GP1_FN[5:0]					GP1_DIR	GP1_OP_CFG	GP1_IP_CFG	GP1_LVL	GP1_PD	GP1_PU	GP1_INTMODE	GP1_DB	0000_0000_1010_1000		
117	75	GPIO Control 2	0	0	GP2_FN[5:0]					GP2_DIR	GP2_OP_CFG	GP2_IP_CFG	GP2_LVL	GP2_PD	GP2_PU	GP2_INTMODE	GP2_DB	0000_0000_1010_1000		
118	76	GPIO Control 3	0	0	GP3_FN[5:0]					GP3_DIR	GP3_OP_CFG	GP3_IP_CFG	GP3_LVL	GP3_PD	GP3_PU	GP3_INTMODE	GP3_DB	0000_0000_1010_1000		
119	77	GPIO Control 4	0	0	GP4_FN[5:0]					GP4_DIR	GP4_OP_CFG	GP4_IP_CFG	GP4_LVL	GP4_PD	GP4_PU	GP4_INTMODE	GP4_DB	0000_0010_0010_0000		
120	78	GPIO Control 5	0	0	GP5_FN[5:0]					GP5_DIR	GP5_OP_CFG	GP5_IP_CFG	GP5_LVL	GP5_PD	GP5_PU	GP5_INTMODE	GP5_DB	0000_0001_1010_0000		
121	79	Interrupt Status 1	0	0	WSEQ_BUSY_EINT	0	0	0	0	0	0	0	FLL_LOCK_EINT	GP5_EINT	GP4_EINT	GP3_EINT	GP2_EINT	GP1_EINT	0000_0000_0000_0000	
122	7A	Interrupt Status 1 Mask	1	1	IM_WSEQ_BUSY_EINT	1	1	1	1	1	1	1	IM_FLL_LOCK_EINT	IM_GP5_EINT	IM_GP4_EINT	IM_GP3_EINT	IM_GP2_EINT	IM_GP1_EINT	1111_1111_1111_1111	
123	7B	Interrupt Polarity 1	0	0	0	0	0	0	0	0	0	0	FLL_LOCK_INV	0	0	0	0	0	0000_0000_0000_0000	
126	7E	Interrupt Control	0	0	0	0	0	0	0	0	0	0	0	0	0	0	0	0	IRQ_POL	0000_0000_0000_0000
128	80	FLL Control 1	0	0	0	0	0	0	0	0	FLL_GAIN[3:0]			FLL_HOLD	FLL_FRAC	0	FLL_ENA	0000_0000_0000_0000		
129	81	FLL Control 2	0	0	0	FLL_CLK_SRC[1:0]	FLL_CLK_REF_DIV[1:0]	FLL_CTRL_RATE[2:0]	FLL_OUTDIV[2:0]			FLL_FRATIO[2:0]			0000_0000_0000_0000					
130	82	FLL Control 3	FLL_K[15:0]																0000_0000_0000_0000	
131	83	FLL Control 4	0	0	0	0	0	0	FLL_N[9:0]										0000_0000_0000_0000	
164	A4	Clock Rate Test 4	0	0	1	0	1	0	DMIC_SEL	0	0	0	1	1	1	0	0	0	0010_1000_0011_1000	
172	AC	Analogue Output Bias 0	0	0	0	0	0	0	0	0	PGA_BIAS[2:0]			0	0	0	0	0	0000_0000_0000_0000	
187	BB	Analogue Output Bias 2	0	0	0	0	0	0	0	0	0	0	0	OUTPUTS_BIAS[2:0]					0000_0000_0000_0000	

## REGISTER BITS BY ADDRESS

REGISTER ADDRESS	BIT	LABEL	DEFAULT	DESCRIPTION	REFER TO
R0 (00h) SW Reset and ID	15:0	SW_RST_DEV_ID1 [15:0]	1000_1001_0000_0011	Writing to this register resets all registers to their default state. Reading from this register will indicate Device ID 8903h.	

Register 00h SW Reset and ID

REGISTER ADDRESS	BIT	LABEL	DEFAULT	DESCRIPTION	REFER TO
R1 (01h) Revision Number	3:0	CHIP_REV [3:0]	0000	Reading from this register will indicate the Revision ID. (Read-Only Register)	

Register 01h Revision Number

REGISTER ADDRESS	BIT	LABEL	DEFAULT	DESCRIPTION	REFER TO
R4 (04h) Bias Control 0	4	POBCTRL	1	Selects the bias current source 0 = Normal bias 1 = Start-Up bias	
	3:2	ISEL [1:0]	10	Master Bias control 00 = Normal bias x 0.5 01 = Normal bias x 0.75 10 = Normal bias 11 = Normal bias x 1.5	
	1	STARTUP_BIAS_ENA	0	Enables the Start-Up bias current generator 0 = Disabled 1 = Enabled	
	0	BIAS_ENA	0	Enables the Normal bias current generator (for all analogue functions) 0 = Disabled 1 = Enabled	

Register 04h Bias Control 0

REGISTER ADDRESS	BIT	LABEL	DEFAULT	DESCRIPTION	REFER TO
R5 (05h) VMID Control 0	7	VMID_TIE_ENA	0	VMID buffer to Differential Lineouts 0 = Disabled 1 = Enabled (only applies when relevant outputs are disabled, ie. SPLK=0 or SPKR=0. Resistance is controlled by VROI.)	
	6	BUFIO_ENA	0	VMID buffer to unused input and output pins. 0 = Disabled 1 = Enabled	
	5	VMID_IO_ENA	0	Enables the Start-Up bias current generator 0 = Disabled 1 = Enabled (same functionality as STARTUP_BIAS_ENA)	

REGISTER ADDRESS	BIT	LABEL	DEFAULT	DESCRIPTION	REFER TO
	4:3	VMID_SOFT [1:0]	00	VMID soft start enable / slew rate control 00 = Disabled 01 = Fast soft start 10 = Nominal soft start 11 = Slow soft start	
	2:1	VMID_RES [1:0]	00	VMID Divider Enable and Select 00 = VMID disabled (for OFF mode) 01 = 2 x 50k divider (for normal operation) 10 = 2 x 250k divider (for low power standby) 11 = 2 x 5k divider (for fast start-up)	
	0	VMID_BUF_EN A	0	VMID Buffer Enable 0 = Disabled 1 = Enabled	

Register 05h VMID Control 0

REGISTER ADDRESS	BIT	LABEL	DEFAULT	DESCRIPTION	REFER TO
R8 (08h) Analogue DAC 0	5	DAC_BIAS_BO OST	0	DAC Bias boost 0 = Disable 1 = Enable When DAC Bias boost is enabled, the bias selected by DACBIAS_SEL and DACVMID_BIAS_SEL are both doubled.	
	4:3	DACBIAS_SEL [1:0]	00	DAC bias current select 00 = Normal bias 01 = Normal bias x 0.5 10 = Normal bias x 0.66 11 = Normal bias x 0.75	
	2:1	DACVMID_BIAS_SEL [1:0]	00	DAC VMID buffer bias select 00 = Normal bias 01 = Normal bias x 0.5 10 = Normal bias x 0.66 11 = Normal bias x 0.75	

Register 08h Analogue DAC 0

REGISTER ADDRESS	BIT	LABEL	DEFAULT	DESCRIPTION	REFER TO
R12 (0Ch) Power Management 0	1	INL_ENA	0	Left Input PGA Enable 0 = disabled 1 = enabled	
	0	INR_ENA	0	Right Input PGA Enable 0 = disabled 1 = enabled	

Register 0Ch Power Management 0

REGISTER ADDRESS	BIT	LABEL	DEFAULT	DESCRIPTION	REFER TO
R13 (0Dh) Power Management 1	1	MIXOUTL_EN A	0	Left Output Mixer Enable 0 = disabled 1 = enabled	
	0	MIXOUTR_EN A	0	Right Output Mixer Enable 0 = disabled 1 = enabled	

Register 0Dh Power Management 1

REGISTER ADDRESS	BIT	LABEL	DEFAULT	DESCRIPTION	REFER TO
R14 (0Eh) Power Management 2	1	HPL_PGA_EN A	0	Left Headphone Output Enable 0 = disabled 1 = enabled	
	0	HPR_PGA_EN A	0	Right Headphone Output Enable 0 = disabled 1 = enabled	

Register 0Eh Power Management 2

REGISTER ADDRESS	BIT	LABEL	DEFAULT	DESCRIPTION	REFER TO
R15 (0Fh) Power Management 3	1	LINEOUTL_PG A_ENA	0	Left Line Output Enable 0 = disabled 1 = enabled	
	0	LINEOUTR_PG A_ENA	0	Right Line Output Enable 0 = disabled 1 = enabled	

Register 0Fh Power Management 3

REGISTER ADDRESS	BIT	LABEL	DEFAULT	DESCRIPTION	REFER TO
R16 (10h) Power Management 4	1	MIXSPKL_ENA	0	Left Speaker Mixer Enable 0 = disabled 1 = enabled	
	0	MIXSPKR_EN A	0	Right Speaker Mixer Enable 0 = disabled 1 = enabled	

Register 10h Power Management 4

REGISTER ADDRESS	BIT	LABEL	DEFAULT	DESCRIPTION	REFER TO
R17 (11h) Power Management 5	1	SPKL_ENA	0	Left Speaker Output Enable 0 = disabled 1 = enabled	
	0	SPKR_ENA	0	Right Speaker Output Enable 0 = disabled 1 = enabled	

Register 11h Power Management 5

REGISTER ADDRESS	BIT	LABEL	DEFAULT	DESCRIPTION	REFER TO
R18 (12h) Power Management 6	3	DACL_ENA	0	Left DAC Enable 0 = DAC disabled 1 = DAC enabled	
	2	DACR_ENA	0	Right DAC Enable 0 = DAC disabled 1 = DAC enabled	
	1	DMICL_ENA	0	Digital Microphone DSP Enable 0 = disabled 1 = enabled	
	0	DMICR_ENA	0	Digital Microphone DSP Enable 0 = disabled 1 = enabled	

Register 12h Power Management 6

REGISTER ADDRESS	BIT	LABEL	DEFAULT	DESCRIPTION	REFER TO
R20 (14h) Clock Rates 0	0	MCLKDIV2	0	Enables divide by 2 on MCLK 0 = CLK_SYS = MCLK 1 = CLK_SYS = MCLK / 2	

Register 14h Clock Rates 0

REGISTER ADDRESS	BIT	LABEL	DEFAULT	DESCRIPTION	REFER TO
R21 (15h) Clock Rates 1	15	CLK_SRC_SELECT	0	SYSCLOCK Source Select 0 = MCLK 1 = FLL output	
	13:10	CLK_SYS_RATE [3:0]	0011	CLK_SYS / Sample rate (fs) ratio  if CLK_SYS_MODE = 00 (256*fs related clocks) 0000 = 64*fs 0001 = 128*fs 0010 = 192*fs 0011 = 256*fs 0100 = 384*fs 0101 = 512*fs 0110 = 768*fs 0111 = 1024 *fs 1000 = 1408*fs 1001 = 1536*fs 1010 to 1111 = Reserved  if CLK_SYS_MODE = 01 (272*fs related clocks) 0000 = 68*fs 0001 = 136*fs 0010 = 204*fs 0011 = 272*fs 0100 = 408*fs 0101 = 544*fs 0110 = 816*fs	

REGISTER ADDRESS	BIT	LABEL	DEFAULT	DESCRIPTION	REFER TO
				0111 = 1088 *fs 1000 = 1496*fs 1001 = 1632*fs 1010 to 1111 = Reserved  if CLK_SYS_MODE = 10 (250*fs related clocks) 0000 = 125*fs 0001 = 125*fs 0010 = 250*fs 0011 = 250*fs 0100 = 375*fs 0101 = 500*fs 0110 = 750*fs 0111 = 1000 *fs 1000 = 1000*fs 1001 = 1500*fs 1010 to 1111 = Reserved	
	9:8	CLK_SYS_MODE [1:0]	00	CLK_SYS mode  00 = 256*fs related 01 = 272*fs related 10 = 250*fs related 11 = Reserved	
	3:0	SAMPLE_RATE [3:0]	1000	Selects the Sample Rate (fs) 0000 = 8kHz 0001 = 11.025kHz 0010 = 12kHz 0011 = 16kHz 0100 = 22.05kHz 0101 = 24kHz 0110 = 32kHz 0111 = 44.1kHz 1000 = 48kHz 1001 = 88.2kHz (Not available for Digital Microphone.) 1010 = 96kHz (Not available for Digital Microphone.) 1011 to 1111 = Reserved  If the desired sample rate is not listed in this table, then the closest alternative should be chosen.	

Register 15h Clock Rates 1

REGISTER ADDRESS	BIT	LABEL	DEFAULT	DESCRIPTION	REFER TO
R22 (16h) Clock Rates 2	2	CLK_SYS_ENA	0	System Clock enable 0 = Disabled 1 = Enabled	
	1	CLK_DSP_ENA	0	DSP Clock enable 0 = Disabled 1 = Enabled	

REGISTER ADDRESS	BIT	LABEL	DEFAULT	DESCRIPTION	REFER TO
	0	TO_ENA	0	Zero Cross timeout enable 0 = Disabled 1 = Enabled	

Register 16h Clock Rates 2

REGISTER ADDRESS	BIT	LABEL	DEFAULT	DESCRIPTION	REFER TO
R24 (18h) Audio Interface 0	12	DACL_DATINV	0	Left DAC Invert 0 = Left DAC output not inverted 1 = Left DAC output inverted	
	11	DACR_DATIN V	0	Right DAC Invert 0 = Right DAC output not inverted 1 = Right DAC output inverted	
	10:9	DAC_BOOST [1:0]	00	DAC Digital Input Volume Boost 00 = 0dB 01 = +6dB (Input data must not exceed -6dBFS) 10 = +12dB (Input data must not exceed -12dBFS) 11 = +18dB (Input data must not exceed -18dBFS)	
	8	LOOPBACK	0	Digital Loopback Function 0 = No loopback 1 = Loopback enabled (Digital Microphone data output is directly input to DAC data input)	
	7	AIFTXL_SRC	0	Left Digital Audio channel source 0 = Left DMIC data is output on left channel 1 = Right DMIC data is output on left channel	
	6	AIFTXR_SRC	1	Right Digital Audio channel source 0 = Left DMIC data is output on right channel 1 = Right DMIC data is output on right channel	
	5	AIFDACL_SRC	0	Left DAC Data Source Select 0 = Left DAC outputs left channel data 1 = Left DAC outputs right channel data	
	4	AIFDACR_SR C	1	Right DAC Data Source Select 0 = Right DAC outputs left channel data 1 = Right DAC outputs right channel data	
	3	DMIC_COMP	0	DMIC Companding Enable 0 = disabled 1 = enabled	
	2	DMIC_COMPM ODE	0	DMIC Companding Type 0 = $\mu$ -law 1 = A-law	
	1	DAC_COMP	0	DAC Companding Enable 0 = disabled 1 = enabled	
	0	DAC_COMPM ODE	0	DAC Companding Type 0 = $\mu$ -law 1 = A-law	

Register 18h Audio Interface 0

REGISTER ADDRESS	BIT	LABEL	DEFAULT	DESCRIPTION	REFER TO
R25 (19h) Audio Interface 1	13	AIFDAC_TDM	0	DAC TDM Enable 0 = Normal DACDAT operation 1 = TDM enabled on DACDAT	
	12	AIFDAC_TDM_CHAN	0	DACDAT TDM Channel Select 0 = DACDAT data input on slot 0 1 = DACDAT data input on slot 1	
	11	AIFTX_TDM	0	Digital Microphone TDM Enable 0 = Normal AIFTXDAT operation 1 = TDM enabled on AIFTXDAT	
	10	AIFTX_TDM_CHAN	0	AIFTXDAT TDM Channel Select 0 = AIFTXDAT outputs data on slot 0 1 = AIFTXDAT output data on slot 1	
	9	LRCLK_DIR	0	Audio Interface LRC Direction 0 = LRC is input 1 = LRC is output	
	7	AIF_BCLK_INV	0	BCLK Invert 0 = BCLK not inverted 1 = BCLK inverted	
	6	BCLK_DIR	0	Audio Interface BCLK Direction 0 = BCLK is input 1 = BCLK is output	
	4	AIF_LRCLK_INV	0	LRC Polarity / DSP Mode A-B select.  Right, left and I2S modes – LRC polarity 0 = Not Inverted 1 = Inverted  DSP Mode – Mode A-B select 0 = MSB is available on 2nd BCLK rising edge after LRC rising edge (mode A) 1 = MSB is available on 1st BCLK rising edge after LRC rising edge (mode B)	
	3:2	AIF_WL [1:0]	00	Digital Audio Interface Word Length 00 = 16 bits 01 = 20 bits 10 = 24 bits 11 = 32 bits	
1:0	AIF_FMT [1:0]	10	Digital Audio Interface Format 00 = Right Justified 01 = Left Justified 10 = I2S 11 = DSP		

Register 19h Audio Interface 1

REGISTER ADDRESS	BIT	LABEL	DEFAULT	DESCRIPTION	REFER TO
R26 (1Ah) Audio Interface 2	4:0	BCLK_DIV [4:0]	0_1000	BCLK Frequency (Master Mode) 00000 = CLK_SYS 00001 = CLK_SYS / 1.5 00010 = CLK_SYS / 2 00011 = CLK_SYS / 3 00100 = CLK_SYS / 4 00101 = CLK_SYS / 5 00110 = Reserved 00111 = CLK_SYS / 6 01000 = CLK_SYS / 8 (default) 01001 = CLK_SYS / 10 01010 = Reserved 01011 = CLK_SYS / 12 01100 = CLK_SYS / 16 01101 = CLK_SYS / 20 01110 = CLK_SYS / 22 01111 = CLK_SYS / 24 10000 = Reserved 10001 = CLK_SYS / 30 10010 = CLK_SYS / 32 10011 = CLK_SYS / 44 10100 = CLK_SYS / 48	

Register 1Ah Audio Interface 2

REGISTER ADDRESS	BIT	LABEL	DEFAULT	DESCRIPTION	REFER TO
R27 (1Bh) Audio Interface 3	10:0	LRCLK_RATE [10:0]	000_0010_0010	LRC Rate (Master Mode) LRC clock output = BCLK / LRCLK_RATE Integer (LSB = 1) Valid range: 8 to 2047 50:50 LRCLK duty cycle is only guaranteed with even values (8, 10, ... 2046).	

Register 1Bh Audio Interface 3

REGISTER ADDRESS	BIT	LABEL	DEFAULT	DESCRIPTION	REFER TO
R30 (1Eh) DAC Digital Volume Left	8	DACVU	0	DAC Volume Update Writing a 1 to this bit causes left and right DAC volume to be updated simultaneously (Write-Only Register)	
	7:0	DACL_VOL [7:0]	1100_0000	Left DAC Digital Volume 00h = Mute 01h = -71.625dB 02h = -71.250dB ... (0.375dB steps) C0h to FFh = 0dB	

Register 1Eh DAC Digital Volume Left

REGISTER ADDRESS	BIT	LABEL	DEFAULT	DESCRIPTION	REFER TO
R31 (1Fh) DAC Digital Volume Right	8	DACVU	0	DAC Volume Update Writing a 1 to this bit causes left and right DAC volume to be updated simultaneously (Write-Only Register)	
	7:0	DACR_VOL [7:0]	1100_0000	Right DAC Digital Volume 00h = Mute 01h = -71.625dB 02h = -71.250dB ... (0.375dB steps) C0h to FFh = 0dB	

Register 1Fh DAC Digital Volume Right

REGISTER ADDRESS	BIT	LABEL	DEFAULT	DESCRIPTION	REFER TO
R32 (20h) DAC Digital 0	11:8	DMICL_DAC_SVOL [3:0]	0000	Left Digital Sidetone Volume 0000 = -36dB 0001 = -33dB (... 3dB steps) 1011 = -3dB 11XX = 0dB	
	7:4	DMICR_DAC_SVOL [3:0]	0000	Right Digital Sidetone Volume 0000 = -36dB 0001 = -33dB (... 3dB steps) 1011 = -3dB 11XX = 0dB	
	3:2	DMIC_TO_DACL [1:0]	00	Left DAC Digital Sidetone Source 00 = No sidetone 01 = Left Digital Microphone 10 = Right Digital Microphone 11 = Reserved	
	1:0	DMIC_TO_DACR [1:0]	00	Right DAC Digital Sidetone Source 00 = No sidetone 01 = Left Digital Microphone 10 = Right Digital Microphone 11 = Reserved	

Register 20h DAC Digital 0

REGISTER ADDRESS	BIT	LABEL	DEFAULT	DESCRIPTION	REFER TO
R33 (21h) DAC Digital 1	12	DAC_MONO	0	DAC Mono Mix 0 = Stereo 1 = Mono (Mono mix output on enabled DAC)	
	11	DAC_SB_FILTER	0	Selects DAC filter characteristics 0 = Normal mode 1 = Sloping stopband mode (recommended when fs ≤ 24kHz)	

REGISTER ADDRESS	BIT	LABEL	DEFAULT	DESCRIPTION	REFER TO
	10	DAC_MUTERATE	0	DAC Soft Mute Ramp Rate 0 = Fast ramp (fs/2, maximum ramp time is 10.7ms at fs=48k) 1 = Slow ramp (fs/32, maximum ramp time is 171ms at fs=48k)	
	9	DAC_MUTE MODE	0	DAC Soft Mute Mode 0 = Disabling soft-mute (DAC_MUTE=0) will cause the DAC volume to change immediately to DACL_VOL and DACR_VOL settings 1 = Disabling soft-mute (DAC_MUTE=0) will cause the DAC volume to ramp up gradually to the DACL_VOL and DACR_VOL settings	
	3	DAC_MUTE	0	DAC Soft Mute Control 0 = DAC Un-mute 1 = DAC Mute	
	2:1	DEEMPH [1:0]	00	DAC De-Emphasis Control 00 = No de-emphasis 01 = 32kHz sample rate 10 = 44.1kHz sample rate 11 = 48kHz sample rate	
	0	DAC_OSR	0	DAC Oversampling Control 0 = Low power (normal oversample) 1 = High performance (double rate)	

Register 21h DAC Digital 1

REGISTER ADDRESS	BIT	LABEL	DEFAULT	DESCRIPTION	REFER TO
R36 (24h) DMIC Digital Volume Left	8	DMICVU	0	Digital Microphone Volume Update Writing a 1 to this bit causes left and right DMIC volume to be updated simultaneously	
	7:0	DMICL_VOL [7:0]	1100_0000	Left Digital Microphone Volume 00h = Mute 01h = -71.625dB 02h = -71.250dB ... (0.375dB steps) C0h = 0dB ... (0.375dB steps) EFh = +17.625dB F0h to FFh = +17.625dB	

Register 24h DMIC Digital Volume Left

REGISTER ADDRESS	BIT	LABEL	DEFAULT	DESCRIPTION	REFER TO
R37 (25h) DMIC Digital Volume Right	8	DMICVU	0	Digital Microphone Volume Update Writing a 1 to this bit causes left and right DMIC volume to be updated simultaneously	
	7:0	DMICR_VOL [7:0]	1100_0000	Right Digital Microphone Volume 00h = Mute 01h = -71.625dB 02h = -71.250dB ... (0.375dB steps) C0h = 0dB ... (0.375dB steps) EFh = +17.625dB F0h to FFh = +17.625dB	

Register 25h DMIC Digital Volume Right

REGISTER ADDRESS	BIT	LABEL	DEFAULT	DESCRIPTION	REFER TO
R38 (26h) DMIC Digital 0	1	TXL_DATINV	0	Left Digital Microphone Invert 0 = Left DMIC output not inverted 1 = Left DMIC output inverted	
	0	TXR_DATINV	0	Right Digital Microphone Invert 0 = Right DMIC output not inverted 1 = Right DMIC output inverted	

Register 26h DMIC Digital 0

REGISTER ADDRESS	BIT	LABEL	DEFAULT	DESCRIPTION	REFER TO
R39 (27h) Digital Microphone 0	10:9	DIGMIC_SRC_SEL [1:0]	00	Digital Microphone Data Select 00 = GPIO2 01 = GPIO3 10 = IN1L 11 = IN2R	

Register 27h Digital Microphone 0

REGISTER ADDRESS	BIT	LABEL	DEFAULT	DESCRIPTION	REFER TO
R40 (28h) DRC 0	15	DRC_ENA	0	DRC enable 1 = enabled 0 = disabled	
	12:11	DRC_THRESH_HYST [1:0]	01	Gain smoothing hysteresis threshold 00 = Low 01 = Medium (recommended) 10 = High 11 = Reserved	
	10:6	DRC_STARTUP_GAIN [4:0]	0_0110	Initial gain at DRC startup 00000 = -18dB 00001 = -15dB 00010 = -12dB 00011 = -9dB 00100 = -6dB 00101 = -3dB 00110 = 0dB (default) 00111 = 3dB 01000 = 6dB 01001 = 9dB 01010 = 12dB 01011 = 15dB 01100 = 18dB 01101 = 21dB 01110 = 24dB 01111 = 27dB 10000 = 30dB 10001 = 33dB 10010 = 36dB 10011 to 11111 = Reserved	
	5	DRC_FF_DELAY	1	Feed-forward delay for anti-clip feature 0 = 5 samples 1 = 9 samples Time delay can be calculated as $5/f_s$ or $9/f_s$ , where $f_s$ is the sample rate.	
	3	DRC_SMOOTH_ENA	1	Gain smoothing enable 0 = disabled 1 = enabled	
	2	DRC_QR_ENA	1	Quick release enable 0 = disabled 1 = enabled	
	1	DRC_ANTICLIP_ENA	1	Anti-clip enable 0 = disabled 1 = enabled	
0	DRC_HYST_ENA	1	Gain smoothing hysteresis enable 0 = disabled 1 = enabled		

Register 28h DRC 0

REGISTER ADDRESS	BIT	LABEL	DEFAULT	DESCRIPTION	REFER TO
R41 (29h) DRC 1	15:12	DRC_ATTACK_RATE [3:0]	0011	Gain attack rate (seconds/6dB) 0000 = Reserved 0001 = 182µs 0010 = 363µs 0011 = 726µs (default) 0100 = 1.45ms 0101 = 2.9ms 0110 = 5.8ms 0111 = 11.6ms 1000 = 23.2ms 1001 = 46.4ms 1010 = 92.8ms 1011-1111 = Reserved	
	11:8	DRC_DECAY_RATE [3:0]	0010	Gain decay rate (seconds/6dB) 0000 = 186ms 0001 = 372ms 0010 = 743ms (default) 0011 = 1.49s 0100 = 2.97s 0101 = 5.94s 0110 = 11.89s 0111 = 23.78s 1000 = 47.56s 1001-1111 = Reserved	
	7:6	DRC_THRESH_QR [1:0]	01	Quick release crest factor threshold 00 = 12dB 01 = 18dB (default) 10 = 24dB 11 = 30dB	
	5:4	DRC_RATE_QR [1:0]	00	Quick release decay rate (seconds/6dB) 00 = 0.725ms (default) 01 = 1.45ms 10 = 5.8ms 11 = Reserved	
	3:2	DRC_MINGAIN [1:0]	00	Minimum gain the DRC can use to attenuate audio signals 00 = 0dB (default) 01 = -6dB 10 = -12dB 11 = -18dB	
	1:0	DRC_MAXGAIN [1:0]	01	Maximum gain the DRC can use to boost audio signals 00 = 12dB 01 = 18dB (default) 10 = 24dB 11 = 36dB	

Register 29h DRC 1

REGISTER ADDRESS	BIT	LABEL	DEFAULT	DESCRIPTION	REFER TO
R42 (2Ah) DRC 2	5:3	DRC_R0_SLO PE_COMP [2:0]	100	Compressor slope R0 000 = 1 (no compression) 001 = 1/2 010 = 1/4 011 = 1/8 100 = 1/16 101 = 0 110 = Reserved 111 = Reserved	
	2:0	DRC_R1_SLO PE_COMP [2:0]	000	Compressor slope R1 000 = 1 (no compression) 001 = 1/2 010 = 1/4 011 = 1/8 100 = 0 101 = Reserved 11X = Reserved	

Register 2Ah DRC 2

REGISTER ADDRESS	BIT	LABEL	DEFAULT	DESCRIPTION	REFER TO
R43 (2Bh) DRC 3	10:5	DRC_THRESH _COMP [5:0]	00_0000	Compressor threshold T (dB) 000000 = 0dB 000001 = -0.75dB 000010 = -1.5dB ... (-0.75dB steps) 111100 = -45dB 111101 = Reserved 11111X = Reserved	
	4:0	DRC_AMP_CO MP [4:0]	0_0000	Compressor amplitude at threshold YT (dB) 00000 = 0dB 00001 = -0.75dB 00010 = -1.5dB ... (-0.75dB steps) 11110 = -22.5dB 11111 = Reserved	

Register 2Bh DRC 3

REGISTER ADDRESS	BIT	LABEL	DEFAULT	DESCRIPTION	REFER TO
R44 (2Ch) Analogue Left Input 0	7	LINMUTE	1	Left Input PGA Mute 0 = not muted 1 = muted	
	4:0	LIN_VOL [4:0]	0_0101	Left Input PGA Volume  If L_MODE = 00 (Single ended) OR L_MODE = 01 (Differential Line) 00000 -1.55 00001 -1.3 00010 -1.0 00011 -0.7 00100 -0.3 00101 +0.0 (default) 00110 +0.3 00111 +0.7 01000 +1.0 01001 +1.4 01010 +1.8 01011 +2.3 01100 +2.7 01101 +3.2 01110 +3.7 01111 +4.2 10000 +4.8 10001 +5.4 10010 +6.0 10011 +6.7 10100 +7.5 10101 +8.3 10110 +9.2 10111 +10.2 11000 +11.4 11001 +12.7 11010 +14.3 11011 +16.2 11100 +19.2 11101 +22.3 11110 +25.2 11111 +28.3  If L_MODE = 1X (Differential MIC) 00000 Not valid 00001 +12 00010 +15 00011 +18 00100 +21 00101 (default) +24 00110 +27 00111 +30 01XXX +30 1XXXX +30	

Register 2Ch Analogue Left Input 0

REGISTER ADDRESS	BIT	LABEL	DEFAULT	DESCRIPTION	REFER TO
R45 (2Dh) Analogue Right Input 0	7	RINMUTE	1	Right Input PGA Mute 0 = not muted 1 = muted	
	4:0	RIN_VOL [4:0]	0_0101	Right Input PGA Volume  If R_MODE = 00 (Single ended) OR R_MODE = 01 (Differential Line) 00000 -1.55 00001 -1.3 00010 -1.0 00011 -0.7 00100 -0.3 00101 +0.0 (default) 00110 +0.3 00111 +0.7 01000 +1.0 01001 +1.4 01010 +1.8 01011 +2.3 01100 +2.7 01101 +3.2 01110 +3.7 01111 +4.2 10000 +4.8 10001 +5.4 10010 +6.0 10011 +6.7 10100 +7.5 10101 +8.3 10110 +9.2 10111 +10.2 11000 +11.4 11001 +12.7 11010 +14.3 11011 +16.2 11100 +19.2 11101 +22.3 11110 +25.2 11111 +28.3  If R_MODE = 1X (Differential MIC) 00000 Not valid 00001 +12 00010 +15 00011 +18 00100 +21 00101 (default) +24 00110 +27 00111 +30 01XXX +30 1XXXX +30	

Register 2Dh Analogue Right Input 0

REGISTER ADDRESS	BIT	LABEL	DEFAULT	DESCRIPTION	REFER TO
R46 (2Eh) Analogue Left Input 1	6	INL_CM_ENA	1	Left Input PGA Common Mode Rejection enable 0 = Disabled 1 = Enabled (only available for L_MODE=01 – Differential Line)	
	5:4	L_IP_SEL_N [1:0]	00	In Single-Ended or Differential Line Modes, this field selects the input pin for the inverting side of the left input path. In Differential Mic Mode, this field selects the input pin for the non-inverting side of the left input path. 00 = IN1L 01 = IN2L 1X = Reserved	
	3:2	L_IP_SEL_P [1:0]	01	In Single-Ended or Differential Line Modes, this field selects the input pin for the non-inverting side of the left input path. In Differential Mic Mode, this field selects the input pin for the inverting side of the left input path. 00 = IN1L 01 = IN2L 1X = Reserved	
	1:0	L_MODE [1:0]	00	Sets the mode for the left analogue input: 00 = Single-Ended 01 = Differential Line 10 = Differential MIC 11 = Reserved	

Register 2Eh Analogue Left Input 1

REGISTER ADDRESS	BIT	LABEL	DEFAULT	DESCRIPTION	REFER TO
R47 (2Fh) Analogue Right Input 1	6	INR_CM_ENA	1	Right Input PGA Common Mode Rejection enable 0 = Disabled 1 = Enabled (only available for R_MODE=01 – Differential Line)	
	5:4	R_IP_SEL_N [1:0]	00	In Single-Ended or Differential Line Modes, this field selects the input pin for the inverting side of the right input path. In Differential Mic Mode, this field selects the input pin for the non-inverting side of the right input path. 00 = IN1R 01 = IN2R 1X = Reserved	
	3:2	R_IP_SEL_P [1:0]	01	In Single-Ended or Differential Line Modes, this field selects the input pin for the non-inverting side of the right input path. In Differential Mic Mode, this field selects the input pin for the inverting side of the right input path. 00 = IN1R 01 = IN2R 1X = Reserved	

REGISTER ADDRESS	BIT	LABEL	DEFAULT	DESCRIPTION	REFER TO
	1:0	R_MODE [1:0]	00	Sets the mode for the right analogue input: 00 = Single-Ended 01 = Differential Line 10 = Differential MIC 11 = Reserved	

Register 2Fh Analogue Right Input 1

REGISTER ADDRESS	BIT	LABEL	DEFAULT	DESCRIPTION	REFER TO
R50 (32h) Analogue Left Mix 0	3	DACL_TO_MIX OUTL	1	Left DAC to Left Output Mixer Enable 0 = disabled 1 = enabled	
	2	DACR_TO_MI XOUTL	0	Right DAC to Left Output Mixer Enable 0 = disabled 1 = enabled	
	1	BYPASSL_TO_ MIXOUTL	0	Left Analogue Input to Left Output Mixer Enable 0 = disabled 1 = enabled	
	0	BYPASSR_TO_ _MIXOUTL	0	Right Analogue Input to Left Output Mixer Enable 0 = disabled 1 = enabled	

Register 32h Analogue Left Mix 0

REGISTER ADDRESS	BIT	LABEL	DEFAULT	DESCRIPTION	REFER TO
R51 (33h) Analogue Right Mix 0	3	DACL_TO_MIX OUTR	0	Left DAC to Right Output Mixer Enable 0 = disabled 1 = enabled	
	2	DACR_TO_MI XOUTR	1	Right DAC to Right Output Mixer Enable 0 = disabled 1 = enabled	
	1	BYPASSL_TO_ MIXOUTR	0	Left Analogue Input to Right Output Mixer Enable 0 = disabled 1 = enabled	
	0	BYPASSR_TO_ _MIXOUTR	0	Right Analogue Input to Right Output Mixer Enable 0 = disabled 1 = enabled	

Register 33h Analogue Right Mix 0

REGISTER ADDRESS	BIT	LABEL	DEFAULT	DESCRIPTION	REFER TO
R52 (34h) Analogue Spk Mix Left 0	3	DACL_TO_MIX SPKL	0	Left DAC to Left Spkr Mixer Enable 0 = disabled 1 = enabled	
	2	DACR_TO_MI XSPKL	0	Right DAC to Left Spkr Mixer Enable 0 = disabled 1 = enabled	
	1	BYPASSL_TO_ MIXSPKL	0	Left Analogue Input to Left Spkr Mixer Enable 0 = disabled 1 = enabled	

REGISTER ADDRESS	BIT	LABEL	DEFAULT	DESCRIPTION	REFER TO
	0	BYPASSR_TO_MIXSPKL	0	Right Analogue Input to Left Spkr Mixer Enable 0 = disabled 1 = enabled	

**Register 34h** Analogue Spk Mix Left 0

REGISTER ADDRESS	BIT	LABEL	DEFAULT	DESCRIPTION	REFER TO
R53 (35h) Analogue Spk Mix Left 1	3	DACL_MIXSPK L_VOL	0	Left DAC to Left Spkr Mixer volume control 0 = 0dB 1 = -6dB	
	2	DACR_MIXSP KL_VOL	0	Right DAC to Left Spkr Mixer volume control 0 = 0dB 1 = -6dB	
	1	BYPASSL_MIX SPKL_VOL	0	Left Analogue Input to Left Spkr Mixer volume control 0 = 0dB 1 = -6dB	
	0	BYPASSR_MI XSPKL_VOL	0	Right Analogue Input to Left Spkr Mixer volume control 0 = 0dB 1 = -6dB	

**Register 35h** Analogue Spk Mix Left 1

REGISTER ADDRESS	BIT	LABEL	DEFAULT	DESCRIPTION	REFER TO
R54 (36h) Analogue Spk Mix Right 0	3	DACL_TO_MIX SPKR	0	Left DAC to Right Spkr Mixer Enable 0 = disabled 1 = enabled	
	2	DACR_TO_MI XSPKR	0	Right DAC to Right Spkr Mixer Enable 0 = disabled 1 = enabled	
	1	BYPASSL_TO_ MIXSPKR	0	Left Analogue Input to Right Spkr Mixer Enable 0 = disabled 1 = enabled	
	0	BYPASSR_TO _MIXSPKR	0	Right Analogue Input to Right Spkr Mixer Enable 0 = disabled 1 = enabled	

**Register 36h** Analogue Spk Mix Right 0

REGISTER ADDRESS	BIT	LABEL	DEFAULT	DESCRIPTION	REFER TO
R55 (37h) Analogue Spk Mix Right 1	3	DACL_MIXSPK R_VOL	0	Left DAC to Right Spkr Mixer volume control 0 = 0dB 1 = -6dB	
	2	DACR_MIXSP KR_VOL	0	Right DAC to Right Spkr Mixer volume control 0 = 0dB 1 = -6dB	

REGISTER ADDRESS	BIT	LABEL	DEFAULT	DESCRIPTION	REFER TO
	1	BYPASSL_MIX SPKR_VOL	0	Left Analogue Input to Right Spkr Mixer volume control 0 = 0dB 1 = -6dB	
	0	BYPASSR_MI XSPKR_VOL	0	Right Analogue Input to Right Spkr Mixer volume control 0 = 0dB 1 = -6dB	

Register 37h Analogue Spk Mix Right 1

REGISTER ADDRESS	BIT	LABEL	DEFAULT	DESCRIPTION	REFER TO
R57 (39h) Analogue OUT1 Left	8	HPL_MUTE	0	Left Headphone Output Mute 0 = Un-mute 1 = Mute	
	7	HPOUTVU	0	Headphone Output Volume Update Writing a 1 to this bit will update HPOUTL and HPOUTR volumes simultaneously. (Write-Only Register)	
	6	HPOUTLZC	0	Left Headphone Output Zero Cross Enable 0 = disabled 1 = enabled	
	5:0	HPOUTL_VOL [5:0]	10_1101	Left Headphone Output Volume 000000 = -57dB 000001 = -56dB (... 1dB steps) 111001 = 0dB (... 1dB steps) 111110 = +5dB 111111 = +6dB	

Register 39h Analogue OUT1 Left

REGISTER ADDRESS	BIT	LABEL	DEFAULT	DESCRIPTION	REFER TO
R58 (3Ah) Analogue OUT1 Right	8	HPR_MUTE	0	Right Headphone Output Mute 0 = Un-mute 1 = Mute	
	7	HPOUTVU	0	Headphone Output Volume Update Writing a 1 to this bit will update HPOUTL and HPOUTR volumes simultaneously. (Write-Only Register)	
	6	HPOUTRZC	0	Right Headphone Output Zero Cross Enable 0 = disabled 1 = enabled	
	5:0	HPOUTR_VOL [5:0]	10_1101	Right Headphone Output Volume 000000 = -57dB 000001 = -56dB (... 1dB steps) 111001 = 0dB (... 1dB steps) 111110 = +5dB	

REGISTER ADDRESS	BIT	LABEL	DEFAULT	DESCRIPTION	REFER TO
				111111 = +6dB	

**Register 3Ah** Analogue OUT1 Right

REGISTER ADDRESS	BIT	LABEL	DEFAULT	DESCRIPTION	REFER TO
R59 (3Bh) Analogue OUT2 Left	8	LINEOUTL_MUTE	0	Left Line Output Mute 0 = Un-mute 1 = Mute	
	7	LINEOUTVU	0	Line Output Volume Update Writing a 1 to this bit will update LINEOUTL and LINEOUTR volumes simultaneously. (Write-Only Register)	
	6	LINEOUTLZC	0	Left Line Output Zero Cross Enable 0 = disabled 1 = enabled	
	5:0	LINEOUTL_VOLUME [5:0]	11_1001	Left Line Output Volume 000000 = -57dB 000001 = -56dB (... 1dB steps) 111001 = 0dB (... 1dB steps) 111110 = +5dB 111111 = +6dB	

**Register 3Bh** Analogue OUT2 Left

REGISTER ADDRESS	BIT	LABEL	DEFAULT	DESCRIPTION	REFER TO
R60 (3Ch) Analogue OUT2 Right	8	LINEOUTR_MUTE	0	Right Line Output Mute 0 = Un-mute 1 = Mute	
	7	LINEOUTVU	0	Line Output Volume Update Writing a 1 to this bit will update LINEOUTL and LINEOUTR volumes simultaneously. (Write-Only Register)	
	6	LINEOUTRZC	0	Right Line Output Zero Cross Enable 0 = disabled 1 = enabled	
	5:0	LINEOUTR_VOLUME [5:0]	11_1001	Right Line Output Volume 000000 = -57dB 000001 = -56dB (... 1dB steps) 111001 = 0dB (... 1dB steps) 111110 = +5dB 111111 = +6dB	

**Register 3Ch** Analogue OUT2 Right

REGISTER ADDRESS	BIT	LABEL	DEFAULT	DESCRIPTION	REFER TO
R62 (3Eh) Analogue OUT3 Left	8	SPKL_MUTE	1	Left Speaker Output Mute 0 = Un-mute 1 = Mute	
	7	SPKVU	0	Speaker Output Volume Update Writing a 1 to this bit will update LON/LOP and RON/ROP volumes simultaneously. (Write-Only Register)	
	6	SPKLZC	0	Left Speaker Output Zero Cross Enable 0 = disabled 1 = enabled	
	5:0	SPKL_VOL [5:0]	11_1001	Left Speaker Output Volume 000000 = -57dB 000001 = -56dB (... 1dB steps) 111001 = 0dB (... 1dB steps) 111110 = +5dB 111111 = +6dB	

Register 3Eh Analogue OUT3 Left

REGISTER ADDRESS	BIT	LABEL	DEFAULT	DESCRIPTION	REFER TO
R63 (3Fh) Analogue OUT3 Right	8	SPKR_MUTE	1	Right Speaker Output Mute 0 = Un-mute 1 = Mute	
	7	SPKVU	0	Speaker Output Volume Update Writing a 1 to this bit will update LON/LOP and RON/ROP volumes simultaneously. (Write-Only Register)	
	6	SPKRZC	0	Right Speaker Output Zero Cross Enable 0 = disabled 1 = enabled	
	5:0	SPKR_VOL [5:0]	11_1001	Right Speaker Output Volume 000000 = -57dB 000001 = -56dB (... 1dB steps) 111001 = 0dB (... 1dB steps) 111110 = +5dB 111111 = +6dB	

Register 3Fh Analogue OUT3 Right

REGISTER ADDRESS	BIT	LABEL	DEFAULT	DESCRIPTION	REFER TO
R65 (41h) Analogue SPK Output Control 0	1	SPK_DISCHA RGE	0	Speaker Discharge Enable 0 = Disabled 1 = Enable	
	0	VROI	0	Select VMID_TIE_ENA resistance for disabled Differential Lineouts 0 = 20k ohm 1 = 500 ohm	

Register 41h Analogue SPK Output Control 0

REGISTER ADDRESS	BIT	LABEL	DEFAULT	DESCRIPTION	REFER TO
R67 (43h) DC Servo 0	4	DCS_MASTER _ENA	1	DC Servo Master Control 0 = DC Servo Reset 1 = DC Servo Enabled	
	3:0	DCS_ENA [3:0]	0000	DC Servo Enable [3] - HPOUTL enable [2] - HPOUTR enable [1] - LINEOUTL enable [0] - LINEOUTR enable	

Register 43h DC Servo 0

REGISTER ADDRESS	BIT	LABEL	DEFAULT	DESCRIPTION	REFER TO
R69 (45h) DC Servo 2	1:0	DCS_MODE [1:0]	00	DC Servo Mode 00 = WRITE_STOP 01 = WRITE_UPDATE 10 = START_STOP 11 = START_UPDATE	

Register 45h DC Servo 2

REGISTER ADDRESS	BIT	LABEL	DEFAULT	DESCRIPTION	REFER TO
R71 (47h) DC Servo 4	7:0	DCS_HPOUTL _WRITE_VAL [7:0]	0000_0000	Value to send to Left Headphone Output Servo in a WRITE mode Two's complement format. LSB is 0.25mV. Range is +/-32mV	

Register 47h DC Servo 4

REGISTER ADDRESS	BIT	LABEL	DEFAULT	DESCRIPTION	REFER TO
R72 (48h) DC Servo 5	7:0	DCS_HPOUTR _WRITE_VAL [7:0]	0000_0000	Value to send to Right Headphone Output Servo in a WRITE mode Two's complement format. LSB is 0.25mV. Range is +/-32mV	

Register 48h DC Servo 5

REGISTER ADDRESS	BIT	LABEL	DEFAULT	DESCRIPTION	REFER TO
R73 (49h) DC Servo 6	7:0	DCS_LOUTL_ WRITE_VAL [7:0]	0000_0000	Value to send to Left Line Output Servo in a WRITE mode Two's complement format. LSB is 0.25mV. Range is +/-32mV	

Register 49h DC Servo 6

REGISTER ADDRESS	BIT	LABEL	DEFAULT	DESCRIPTION	REFER TO
R74 (4Ah) DC Servo 7	7:0	DCS_LOUTR_ WRITE_VAL [7:0]	0000_0000	Value to send to Right Line Output Servo in a WRITE mode Two's complement format. LSB is 0.25mV. Range is +/-32mV	

Register 4Ah DC Servo 7

REGISTER ADDRESS	BIT	LABEL	DEFAULT	DESCRIPTION	REFER TO
R81 (51h) DC Servo Readback 1	7:0	DCS_HPOUTL_ INTEG [7:0]	0000_0000	Readback value on Left Headphone Output Servo. Two's complement format. LSB is 0.25mV. Range is +/-32mV (Read-Only Register)	

Register 51h DC Servo Readback 1

REGISTER ADDRESS	BIT	LABEL	DEFAULT	DESCRIPTION	REFER TO
R82 (52h) DC Servo Readback 2	7:0	DCS_HPOUTR_ INTEG [7:0]	0000_0000	Readback value on Headphone Right Output Servo. Two's complement format. LSB is 0.25mV. Range is +/-32mV (Read-Only Register)	

Register 52h DC Servo Readback 2

REGISTER ADDRESS	BIT	LABEL	DEFAULT	DESCRIPTION	REFER TO
R83 (53h) DC Servo Readback 3	7:0	DCS_LOUTL_ NTEG [7:0]	0000_0000	Readback value on Left Line Output Servo. Two's complement format. LSB is 0.25mV. Range is +/-32mV (Read-Only Register)	

Register 53h DC Servo Readback 3

REGISTER ADDRESS	BIT	LABEL	DEFAULT	DESCRIPTION	REFER TO
R84 (54h) DC Servo Readback 4	7:0	DCS_LOUTR_I NTEG [7:0]	0000_0000	Readback value on Right Line Output Servo. Two's complement format. LSB is 0.25mV. Range is +/-32mV (Read-Only Register)	

**Register 54h** DC Servo Readback 4

REGISTER ADDRESS	BIT	LABEL	DEFAULT	DESCRIPTION	REFER TO
R90 (5Ah) Analogue HP 0	7	HPL_RMV_SH ORT	0	Removes HPL short 0 = HPL short enabled 1 = HPL short removed For normal operation, this bit should be set as the final step of the HPL Enable sequence.	
	6	HPL_ENA_OU TP	0	Enables HPL output stage 0 = Disabled 1 = Enabled For normal operation, this bit should be set to 1 after the DC offset cancellation has been scheduled.	
	5	HPL_ENA_DLY	0	Enables HPL intermediate stage 0 = Disabled 1 = Enabled For normal operation, this bit should be set to 1 after the output signal path has been configured, and before DC offset cancellation is scheduled. This bit should be set with at least 20us delay after HPL_ENA.	
	4	HPL_ENA	0	Enables HPL input stage 0 = Disabled 1 = Enabled For normal operation, this bit should be set as the first step of the HPL Enable sequence.	
	3	HPR_RMV_SH ORT	0	Removes HPR short 0 = HPR short enabled 1 = HPR short removed For normal operation, this bit should be set as the final step of the HPR Enable sequence.	
	2	HPR_ENA_OU TP	0	Enables HPR output stage 0 = Disabled 1 = Enabled For normal operation, this bit should be set to 1 after the DC offset cancellation has been scheduled.	
	1	HPR_ENA_DL Y	0	Enables HPR intermediate stage 0 = Disabled 1 = Enabled For normal operation, this bit should be set to 1 after the output signal path has been configured, and before DC offset cancellation is scheduled. This bit should be set with at least 20us delay after HPR_ENA.	
	0	HPR_ENA	0	Enables HPR input stage 0 = Disabled 1 = Enabled For normal operation, this bit should be set as the first step of the HPR Enable sequence.	

**Register 5Ah** Analogue HP 0

REGISTER ADDRESS	BIT	LABEL	DEFAULT	DESCRIPTION	REFER TO
R94 (5Eh) Analogue Lineout 0	7	LINEOUTL_RM V_SHORT	0	Removes LINEOUTL short 0 = LINEOUTL short enabled 1 = LINEOUTL short removed For normal operation, this bit should be set as the final step of the LINEOUTL Enable sequence.	
	6	LINEOUTL_EN A_OUTP	0	Enables LINEOUTL output stage 0 = Disabled 1 = Enabled For normal operation, this bit should be set to 1 after the DC offset cancellation has been scheduled.	
	5	LINEOUTL_EN A_DLY	0	Enables LINEOUTL intermediate stage 0 = Disabled 1 = Enabled For normal operation, this bit should be set to 1 after the output signal path has been configured, and before DC offset cancellation is scheduled. This bit should be set with at least 20us delay after LINEOUTL_ENA.	
	4	LINEOUTL_EN A	0	Enables LINEOUTL input stage 0 = Disabled 1 = Enabled For normal operation, this bit should be set as the first step of the LINEOUTL Enable sequence.	
	3	LINEOUTR_R MV_SHORT	0	Removes LINEOUTR short 0 = LINEOUTR short enabled 1 = LINEOUTR short removed For normal operation, this bit should be set as the final step of the LINEOUTR Enable sequence.	
	2	LINEOUTR_EN A_OUTP	0	Enables LINEOUTR output stage 0 = Disabled 1 = Enabled For normal operation, this bit should be set to 1 after the DC offset cancellation has been scheduled.	
	1	LINEOUTR_EN A_DLY	0	Enables LINEOUTR intermediate stage 0 = Disabled 1 = Enabled For normal operation, this bit should be set to 1 after the output signal path has been configured, and before DC offset cancellation is scheduled. This bit should be set with at least 20us delay after LINEOUTR_ENA.	
	0	LINEOUTR_EN A	0	Enables LINEOUTR input stage 0 = Disabled 1 = Enabled For normal operation, this bit should be set as the first step of the LINEOUTR Enable sequence.	

Register 5Eh Analogue Lineout 0

REGISTER ADDRESS	BIT	LABEL	DEFAULT	DESCRIPTION	REFER TO
R98 (62h) Charge Pump 0	0	CP_ENA	0	Enable charge-pump digits 0 = disable 1 = enable	

Register 62h Charge Pump 0

REGISTER ADDRESS	BIT	LABEL	DEFAULT	DESCRIPTION	REFER TO
R104 (68h) Class W 0	0	CP_DYN_PWR	0	Enable dynamic charge pump power control 0 = charge pump controlled by volume register settings 1 = charge pump controlled by real-time audio level	

Register 68h Class W 0

REGISTER ADDRESS	BIT	LABEL	DEFAULT	DESCRIPTION	REFER TO
R108 (6Ch) Write Sequencer 0	8	WSMD_CLK_ENA	0	Write Sequencer Clock Enable 0 = Disabled 1 = Enabled	
	4:0	WSEQ_WRITE_INDEX [4:0]	0_0000	Sequence Write Index. This is the memory location to which any updates to R109 and R110 will be copied. 0 to 31 = RAM addresses	

Register 6Ch Write Sequencer 0

REGISTER ADDRESS	BIT	LABEL	DEFAULT	DESCRIPTION	REFER TO
R109 (6Dh) Write Sequencer 1	14:12	WSEQ_DATA_WIDTH [2:0]	000	Width of the data block written in this sequence step. 000 = 1 bit 001 = 2 bits 010 = 3 bits 011 = 4 bits 100 = 5 bits 101 = 6 bits 110 = 7 bits 111 = 8 bits	
	11:8	WSEQ_DATA_START [3:0]	0000	Bit position of the LSB of the data block written in this sequence step. 0000 = Bit 0 ... 1111 = Bit 15	
	7:0	WSEQ_ADDR [7:0]	0000_0000	Control Register Address to be written to in this sequence step.	

Register 6Dh Write Sequencer 1

REGISTER ADDRESS	BIT	LABEL	DEFAULT	DESCRIPTION	REFER TO
R110 (6Eh) Write Sequencer 2	14	WSEQ_EOS	0	End of Sequence flag. This bit indicates whether the Control Write Sequencer should stop after executing this step. 0 = Not end of sequence 1 = End of sequence (Stop the sequencer after this step).	

REGISTER ADDRESS	BIT	LABEL	DEFAULT	DESCRIPTION	REFER TO
	11:8	WSEQ_DELAY [3:0]	0000	Time delay after executing this step. Total delay time per step (including execution)= $62.5\mu\text{s} \times (2^{\text{WSEQ\_DELAY}} + 8)$	
	7:0	WSEQ_DATA [7:0]	0000_0000	Data to be written in this sequence step. When the data width is less than 8 bits, then one or more of the MSBs of WSEQ_DATA are ignored. It is recommended that unused bits be set to 0.	

Register 6Eh Write Sequencer 2

REGISTER ADDRESS	BIT	LABEL	DEFAULT	DESCRIPTION	REFER TO
R111 (6Fh) Write Sequencer 3	9	WSEQ_ABORT	0	Writing a 1 to this bit aborts the current sequence and returns control of the device back to the serial control interface. (Write-Only Register)	
	8	WSEQ_START	0	Writing a 1 to this bit starts the write sequencer at the memory location indicated by the WSEQ_START_INDEX field. The sequence continues until it reaches an "End of sequence" flag. At the end of the sequence, this bit will be reset by the Write Sequencer. (Write-Only Register)	
	5:0	WSEQ_START_INDEX [5:0]	00_0000	Sequence Start Index. This is the memory location of the first command in the selected sequence. 0 to 31 = RAM addresses 32 to 48 = ROM addresses 49 to 63 = Reserved	

Register 6Fh Write Sequencer 3

REGISTER ADDRESS	BIT	LABEL	DEFAULT	DESCRIPTION	REFER TO
R112 (70h) Write Sequencer 4	9:4	WSEQ_CURRENT_INDEX [5:0]	00_0000	Sequence Current Index. This is the location of the most recently accessed command in the write sequencer memory. (Read-Only Register)	
	0	WSEQ_BUSY	0	Sequencer Busy flag 0 = Sequencer idle 1 = Sequencer busy  Note: it is not possible to write to control registers via the control interface while the Sequencer is Busy. (Read-Only Register)	

Register 70h Write Sequencer 4

REGISTER ADDRESS	BIT	LABEL	DEFAULT	DESCRIPTION	REFER TO
R116 (74h) GPIO Control 1	13:8	GP1_FN [5:0]	00_0000	GPIO 1 Pin Function select 00h = GPIO output 01h = Reserved 02h = IRQ output 03h = GPIO input 04h = Reserved 05h = Reserved 06h = DMIC_LR Clock output 07h = Reserved 08h = FLL Lock output 09h = FLL Clock output 0Ah to 3Fh = Reserved	
	7	GP1_DIR	1	GPIO Pin Direction 0 = Output 1 = Input	
	6	GP1_OP_CFG	0	Output pin configuration 0 = CMOS 1 = Open-drain	
	5	GP1_IP_CFG	1	Input pin configuration 0 = Active low 1 = Active high	
	4	GP1_LVL	0	GPIO Output Level (when GP1_FN = 00000) 0 = Logic 0 1 = Logic 1	
	3	GP1_PD	1	GPIO Pull-Down Enable 0 = Pull-down disabled 1 = Pull-down enabled (Approx 100k $\Omega$ )	
	2	GP1_PU	0	GPIO Pull-Up Enable 0 = Pull-up disabled 1 = Pull-up enabled (Approx 100k $\Omega$ )	
	1	GP1_INTMODE	0	GPIO Interrupt Mode 0 = Level triggered 1 = Edge triggered	
	0	GP1_DB	0	GPIO de-bounce 0 = GPIO is not debounced 1 = GPIO is debounced	

Register 74h GPIO Control 1

REGISTER ADDRESS	BIT	LABEL	DEFAULT	DESCRIPTION	REFER TO
R117 (75h) GPIO Control 2	13:8	GP2_FN [5:0]	00_0000	GPIO 2 Pin Function select 00h = GPIO output 01h = Reserved 02h = IRQ output 03h = GPIO input 04h = Reserved 05h = Reserved 06h = DMIC_DAT Data input 07h = DMIC_LR Clock output 08h = FLL Lock output 09h = FLL Clock output 0Ah to 3Fh = Reserved	
	7	GP2_DIR	1	GPIO Pin Direction 0 = Output 1 = Input	
	6	GP2_OP_CFG	0	Output pin configuration 0 = CMOS 1 = Open-drain	
	5	GP2_IP_CFG	1	Input pin configuration 0 = Active low 1 = Active high	
	4	GP2_LVL	0	GPIO Output Level (when GP2_FN = 00000) 0 = Logic 0 1 = Logic 1	
	3	GP2_PD	1	GPIO Pull-Down Enable 0 = Pull-down disabled 1 = Pull-down enabled (Approx 100kΩ)	
	2	GP2_PU	0	GPIO Pull-Up Enable 0 = Pull-up disabled 1 = Pull-up enabled (Approx 100kΩ)	
	1	GP2_INTMODE	0	GPIO Interrupt Mode 0 = Level triggered 1 = Edge triggered	
	0	GP2_DB	0	GPIO de-bounce 0 = GPIO is not debounced 1 = GPIO is debounced	

Register 75h GPIO Control 2

REGISTER ADDRESS	BIT	LABEL	DEFAULT	DESCRIPTION	REFER TO
R118 (76h) GPIO Control 3	13:8	GP3_FN [5:0]	00_0000	GPIO 3 Pin Function select 00h = GPIO output 01h = Reserved 02h = IRQ output 03h = GPIO input 04h = Reserved 05h = Reserved 06h = DMIC_DAT Data input 07h = DMIC_LR Clock output 08h = FLL Lock output 09h = FLL Clock output 0Ah to 3Fh = Reserved	
	7	GP3_DIR	1	GPIO Pin Direction 0 = Output 1 = Input	
	6	GP3_OP_CFG	0	Output pin configuration 0 = CMOS 1 = Open-drain	
	5	GP3_IP_CFG	1	Input pin configuration 0 = Active low 1 = Active high	
	4	GP3_LVL	0	GPIO Output Level (when GP3_FN = 00000) 0 = Logic 0 1 = Logic 1	
	3	GP3_PD	1	GPIO Pull-Down Enable 0 = Pull-down disabled 1 = Pull-down enabled (Approx 100kΩ)	
	2	GP3_PU	0	GPIO Pull-Up Enable 0 = Pull-up disabled 1 = Pull-up enabled (Approx 100kΩ)	
	1	GP3_INTMODE	0	GPIO Interrupt Mode 0 = Level triggered 1 = Edge triggered	
	0	GP3_DB	0	GPIO de-bounce 0 = GPIO is not debounced 1 = GPIO is debounced	

Register 76h GPIO Control 3

REGISTER ADDRESS	BIT	LABEL	DEFAULT	DESCRIPTION	REFER TO
R119 (77h) GPIO Control 4	13:8	GP4_FN [5:0]	00_0010	GPIO 4 Pin Function select 00h = GPIO output 01h = Reserved 02h = IRQ output 03h = GPIO input 04h = Reserved 05h = Reserved 06h = Reserved 07h = DMIC_LR Clock output 08h = FLL Lock output 09h = FLL Clock output 0Ah to 3Fh = Reserved	
	7	GP4_DIR	0	GPIO Pin Direction 0 = Output 1 = Input	
	6	GP4_OP_CFG	0	Output pin configuration 0 = CMOS 1 = Open-drain	
	5	GP4_IP_CFG	1	Input pin configuration 0 = Active low 1 = Active high	
	4	GP4_LVL	0	GPIO Output Level (when GP4_FN = 00000) 0 = Logic 0 1 = Logic 1	
	3	GP4_PD	0	GPIO Pull-Down Enable 0 = Pull-down disabled 1 = Pull-down enabled (Approx 100kΩ)	
	2	GP4_PU	0	GPIO Pull-Up Enable 0 = Pull-up disabled 1 = Pull-up enabled (Approx 100kΩ)	
	1	GP4_INTMODE	0	GPIO Interrupt Mode 0 = Level triggered 1 = Edge triggered	
	0	GP4_DB	0	GPIO de-bounce 0 = GPIO is not debounced 1 = GPIO is debounced	

Register 77h GPIO Control 4

REGISTER ADDRESS	BIT	LABEL	DEFAULT	DESCRIPTION	REFER TO
R120 (78h) GPIO Control 5	13:8	GP5_FN [5:0]	00_0001	GPIO 5 Pin Function select 00h = GPIO output 01h = BCLK 02h = IRQ output 03h = GPIO input 04h = Reserved 05h = Reserved 06h = Reserved 07h = DMIC_LR Clock output 08h = FLL Lock output 09h = FLL Clock output 0Ah to 3Fh = Reserved	
	7	GP5_DIR	1	GPIO Pin Direction 0 = Output 1 = Input	
	6	GP5_OP_CFG	0	Output pin configuration 0 = CMOS 1 = Open-drain	
	5	GP5_IP_CFG	1	Input pin configuration 0 = Active low 1 = Active high	
	4	GP5_LVL	0	GPIO Output Level (when GP5_FN = 00000) 0 = Logic 0 1 = Logic 1	
	3	GP5_PD	0	GPIO Pull-Down Enable 0 = Pull-down disabled 1 = Pull-down enabled (Approx 100kΩ)	
	2	GP5_PU	0	GPIO Pull-Up Enable 0 = Pull-up disabled 1 = Pull-up enabled (Approx 100kΩ)	
	1	GP5_INTMODE	0	GPIO Interrupt Mode 0 = Level triggered 1 = Edge triggered	
	0	GP5_DB	0	GPIO de-bounce 0 = GPIO is not debounced 1 = GPIO is debounced	

Register 78h GPIO Control 5

REGISTER ADDRESS	BIT	LABEL	DEFAULT	DESCRIPTION	REFER TO
R121 (79h) Interrupt Status 1	13	WSEQ_BUSY_EINT	0	Write Sequencer Busy IRQ status 0 = WSEQ IRQ not set 1 = WSEQ IRQ set The Write Sequencer asserts this flag when it has completed a programmed sequence - ie it indicates that the Write Sequencer is NOT Busy. (Read-Only Register)	
	5	FLL_LOCK_EINT	0	FLL Lock IRQ status 0 = FLL Lock IRQ not set 1 = FLL Lock IRQ set	

REGISTER ADDRESS	BIT	LABEL	DEFAULT	DESCRIPTION	REFER TO
				(Read-Only Register)	
	4	GP5_EINT	0	GPIO5 IRQ status 0 = GPIO5 IRQ not set 1 = GPIO5 IRQ set (Read-Only Register)	
	3	GP4_EINT	0	GPIO4 IRQ status 0 = GPIO4 IRQ not set 1 = GPIO4 IRQ set (Read-Only Register)	
	2	GP3_EINT	0	GPIO3 IRQ status 0 = GPIO3 IRQ not set 1 = GPIO3 IRQ set (Read-Only Register)	
	1	GP2_EINT	0	GPIO2 IRQ status 0 = GPIO2 IRQ not set 1 = GPIO2 IRQ set (Read-Only Register)	
	0	GP1_EINT	0	GPIO1 IRQ status 0 = GPIO1 IRQ not set 1 = GPIO1 IRQ set (Read-Only Register)	

Register 79h Interrupt Status 1

REGISTER ADDRESS	BIT	LABEL	DEFAULT	DESCRIPTION	REFER TO
R122 (7Ah) Interrupt Status 1 Mask	13	IM_WSEQ_BU SY_EINT	1	Interrupt mask for WSEQ Busy indication 0 = Not masked 1 = Masked	
	5	IM_FLL_LOCK _EINT	1	Interrupt mask for FLL Lock 0 = Not masked 1 = Masked	
	4	IM_GP5_EINT	1	Interrupt mask for GPIO5 0 = Not masked 1 = Masked	
	3	IM_GP4_EINT	1	Interrupt mask for GPIO4 0 = Not masked 1 = Masked	
	2	IM_GP3_EINT	1	Interrupt mask for GPIO3 0 = Not masked 1 = Masked	
	1	IM_GP2_EINT	1	Interrupt mask for GPIO2 0 = Not masked 1 = Masked	
	0	IM_GP1_EINT	1	Interrupt mask for GPIO1 0 = Not masked 1 = Masked	

Register 7Ah Interrupt Status 1 Mask

REGISTER ADDRESS	BIT	LABEL	DEFAULT	DESCRIPTION	REFER TO
R123 (7Bh) Interrupt Polarity 1	5	FLL_LOCK_IN V	0	FLL Lock polarity 0 = Non-inverted 1 = Inverted	

**Register 7Bh** Interrupt Polarity 1

REGISTER ADDRESS	BIT	LABEL	DEFAULT	DESCRIPTION	REFER TO
R126 (7Eh) Interrupt Control	0	IRQ_POL	0	Interrupt Output polarity 0 = Active high 1 = Active low	

**Register 7Eh** Interrupt Control

REGISTER ADDRESS	BIT	LABEL	DEFAULT	DESCRIPTION	REFER TO
R128 (80h) FLL Control 1	7:4	FLL_GAIN [3:0]	0000	Gain applied to error 0000 = x 1 (Recommended value) 0001 = x 2 0010 = x 4 0011 = x 8 0100 = x 16 0101 = x 32 0110 = x 64 0111 = x 128 1000 = x 256  Recommended that this register is not changed from default.	
	3	FLL_HOLD	0	FLL Hold Select 0 = Disabled 1 = Enabled  This feature enables free-running mode in FLL when reference clock is removed	
	2	FLL_FRAC	0	Fractional enable 0 = Integer Mode 1 = Fractional Mode  Fractional Mode is recommended in all cases	
	0	FLL_ENA	0	FLL Enable 0 = Disabled 1 = Enabled	

**Register 80h** FLL Control 1

REGISTER ADDRESS	BIT	LABEL	DEFAULT	DESCRIPTION	REFER TO
R129 (81h) FLL Control 2	12:11	FLL_CLK_SRC [1:0]	00	FLL Clock source 00 = MCLK 01 = BCLK 10 = LRC 11 = Reserved	
	10:9	FLL_CLK_REF_DIV [1:0]	00	FLL Clock Reference Divider 00 = MCLK / 1 01 = MCLK / 2 10 = MCLK / 4 11 = MCLK / 8  MCLK (or other input reference) must be divided down to <=13.5MHz. For lower power operation, the reference clock can be divided down further if desired.	
	8:6	FLL_CTRL_RATE [2:0]	000	Frequency of the FLL control block 000 = FVCO / 1 (Recommended value) 001 = FVCO / 2 010 = FVCO / 3 011 = FVCO / 4 100 = FVCO / 5 101 = FVCO / 6 110 = FVCO / 7 111 = FVCO / 8  Recommended that this register is not changed from default.	
	5:3	FLL_OUTDIV [2:0]	000	FOUT clock divider 000 = 2 001 = 4 010 = 8 011 = 16 100 = 32 101 = 64 110 = 128 111 = 256  (FOUT = FVCO / FLL_OUTDIV)	
	2:0	FLL_FRATIO [2:0]	000	F <sub>VCO</sub> clock divider 000 = divide by 1 001 = divide by 2 010 = divide by 4 011 = divide by 8 1XX = divide by 16  000 recommended for F <sub>REF</sub> > 1MHz 100 recommended for F <sub>REF</sub> < 64kHz	

Register 81h FLL Control 2

REGISTER ADDRESS	BIT	LABEL	DEFAULT	DESCRIPTION	REFER TO
R130 (82h) FLL Control 3	15:0	FLL_K [15:0]	0000_0000 _0000_000 0	Fractional multiply for FREF (MSB = 0.5)	

**Register 82h** FLL Control 3

REGISTER ADDRESS	BIT	LABEL	DEFAULT	DESCRIPTION	REFER TO
R131 (83h) FLL Control 4	9:0	FLL_N [9:0]	00_0000_0 000	Integer multiply for FREF (LSB = 1)	

**Register 83h** FLL Control 4

REGISTER ADDRESS	BIT	LABEL	DEFAULT	DESCRIPTION	REFER TO
R164 (A4h) Clock Rate Test 4	9	DMIC_SEL	0	Digital Microphone mode. 0 = Disabled 1 = Audio DSP input is from digital microphone interface	

**Register A4h** Clock Rate Test 4

REGISTER ADDRESS	BIT	LABEL	DEFAULT	DESCRIPTION	REFER TO
R172 (ACh) Analogue Output Bias 0	6:4	PGA_BIAS [2:0]	000	Headphone and Lineout PGA bias control 000 = Normal bias 001 = Normal bias x 1.5 010 = Normal bias x 0.75 011 = Normal bias x 0.5 100 = Normal bias x 0.33 101 = Normal bias 110 = Normal bias 111 = Normal bias x2	

**Register ACh** Analogue Output Bias 0

REGISTER ADDRESS	BIT	LABEL	DEFAULT	DESCRIPTION	REFER TO
R187 (BBh) Analogue Output Bias 2	2:0	OUTPUTS_BIAS [2:0]	000	Headphone and Lineout Output Drivers bias control 000 = Normal bias 001 = Normal bias x 1.5 010 = Normal bias x 0.75 011 = Normal bias x 0.5 100 = Normal bias x 0.33 101 = Normal bias 110 = Normal bias 111 = Normal bias x 2	

**Register BBh** Analogue Output Bias 2

## APPLICATIONS INFORMATION

### RECOMMENDED EXTERNAL COMPONENTS

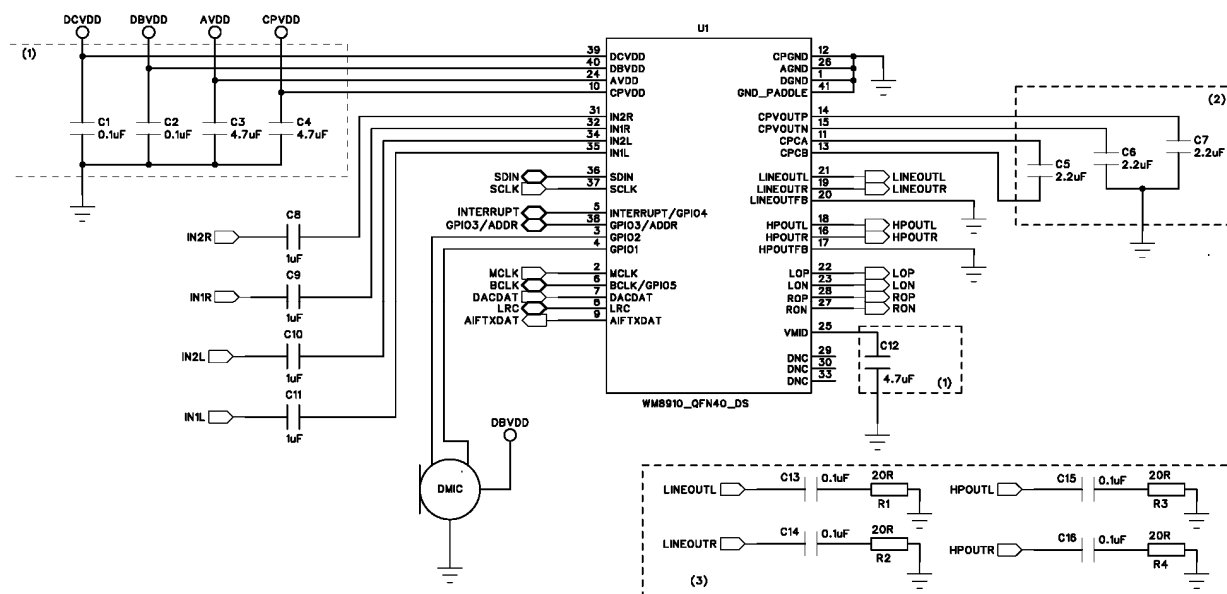

Figure 60 Recommended External Components

**Notes:**

**1. Decoupling Capacitors**

X5R ceramic capacitor is recommended for capacitors C1, C2, C3, C4, C5, C6 and C7.

All decoupling capacitors should be positioned as close to the WM8910 as possible.

The positioning of C12 is particularly important - this should be as close to the WM8910 as possible.

**2. Charge Pump Capacitors**

Specific recommendations for C5, C6 and C7 are provided in Table 77. Note that two different recommendations are provided for these components; either of these components is suitable, depending upon size requirements and availability.

The positioning of C5 is very important - this should be as close to the WM8910 as possible.

It is important to select a suitable capacitor type for the Charge Pump. Note that the capacitance may vary with DC voltage; care is required to ensure that required capacitance is achieved at the applicable operating voltage, as specified in Table 77. The capacitor datasheet should be consulted for this information.

COMPONENT	REQUIRED CAPACITANCE	VALUE	PART NUMBER	VOLTAGE	TYPE	SIZE
C5 (CPCA-CPCB)	≥ 1μF at 2VDC	2.2μF	Kemet C0402C225M9PAC	6.3v	X5R	0402
		2.2μF	MuRata GRM155R60J225ME15_EIA	6.3v	X5R	0402
C6 (CPVOUTN)	≥ 2μF at 2VDC	2.2μF	MuRata GRM188R61A225KE34D	10v	X5R	0603
C7 (CPVOUTP)		4.7μF	MuRata GRM155R60J475M_EIA	6.3v	X5R	0402

Table 77 Charge Pump Capacitors

**3. Zobel Networks**

The Zobel network shown in Figure 60 is required on HPOUTL, HPOUTR, LINEOUTL and LINEOUTR whenever that output is enabled. Stability of these ground-referenced outputs across all process corners cannot be guaranteed without the Zobel network components. (Note that, if any ground-referenced output pin is not required, the zobel network components can be omitted from the output pin, and the pin can be left floating.) The Zobel network requirement is detailed further in the applications note WAN\_0212 "Class W Headphone Impedance Compensation".

Zobel networks (C13, C14, C15, C16, R1, R2, R3, R4) should be positioned reasonably close to the WM8910.

**PACKAGE DIMENSIONS**

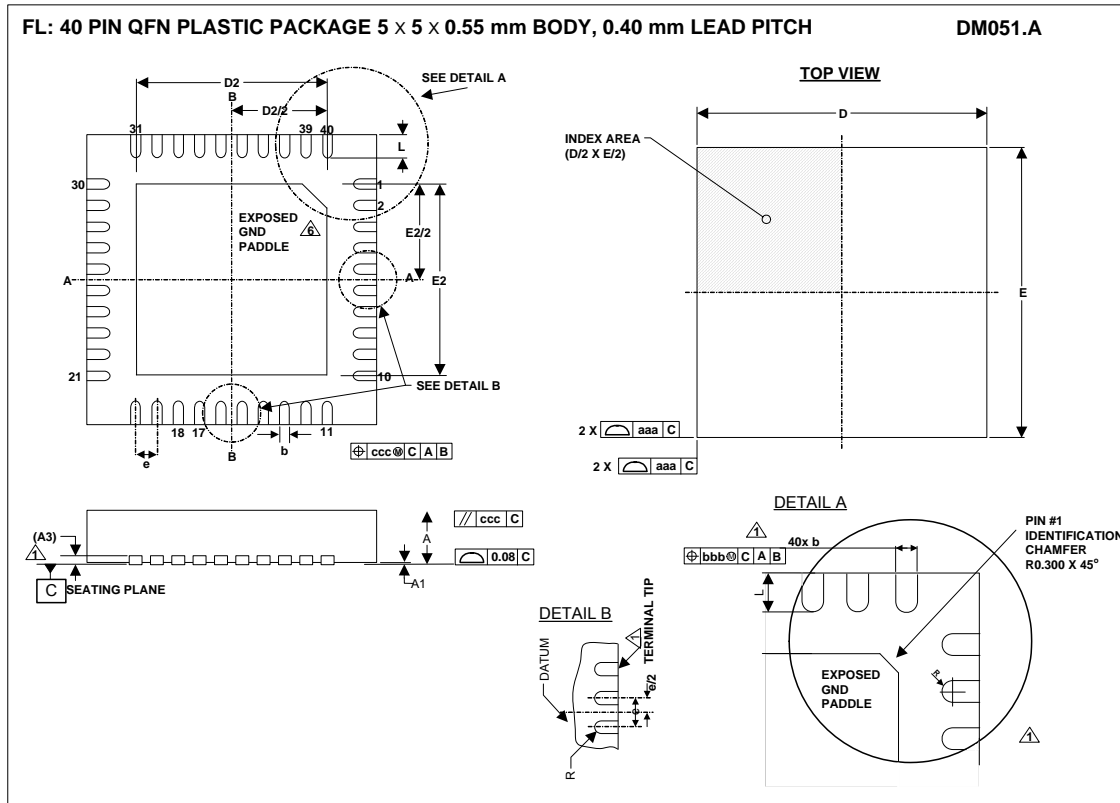

Symbols	Dimensions (mm)			NOTE
	MIN	NOM	MAX	
A	0.50	0.55	0.60	
A1	0	0.02	0.05	
A3		0.203 REF		
b	0.15	0.20	0.25	1
D		5.00 BSC		
D2	3.55	3.6	3.65	2
E		5.00 BSC		
E2	3.55	3.6	3.65	2
e		0.4 BSC		
L	0.35	0.4	0.45	
<b>Tolerances of Form and Position</b>				
aaa	0.15			
bbb	0.10			
ccc	0.10			
REF:	JEDEC, MO-220			

- NOTES:
1. DIMENSION b APPLIED TO METALLIZED TERMINAL AND IS MEASURED BETWEEN 0.25 mm AND 0.30 mm FROM TERMINAL TIP.
  2. FALLS WITHIN JEDEC, MO-220.
  3. ALL DIMENSIONS ARE IN MILLIMETRES
  4. THIS DRAWING IS SUBJECT TO CHANGE WITHOUT NOTICE.
  5. REFER TO APPLICATIONS NOTE WAN\_0118 FOR FURTHER INFORMATION.

## IMPORTANT NOTICE

Wolfson Microelectronics plc ("Wolfson") products and services are sold subject to Wolfson's terms and conditions of sale, delivery and payment supplied at the time of order acknowledgement.

Wolfson warrants performance of its products to the specifications in effect at the date of shipment. Wolfson reserves the right to make changes to its products and specifications or to discontinue any product or service without notice. Customers should therefore obtain the latest version of relevant information from Wolfson to verify that the information is current.

Testing and other quality control techniques are utilised to the extent Wolfson deems necessary to support its warranty. Specific testing of all parameters of each device is not necessarily performed unless required by law or regulation.

In order to minimise risks associated with customer applications, the customer must use adequate design and operating safeguards to minimise inherent or procedural hazards. Wolfson is not liable for applications assistance or customer product design. The customer is solely responsible for its selection and use of Wolfson products. Wolfson is not liable for such selection or use nor for use of any circuitry other than circuitry entirely embodied in a Wolfson product.

Wolfson's products are not intended for use in life support systems, appliances, nuclear systems or systems where malfunction can reasonably be expected to result in personal injury, death or severe property or environmental damage. Any use of products by the customer for such purposes is at the customer's own risk.

Wolfson does not grant any licence (express or implied) under any patent right, copyright, mask work right or other intellectual property right of Wolfson covering or relating to any combination, machine, or process in which its products or services might be or are used. Any provision or publication of any third party's products or services does not constitute Wolfson's approval, licence, warranty or endorsement thereof. Any third party trade marks contained in this document belong to the respective third party owner.

Reproduction of information from Wolfson datasheets is permissible only if reproduction is without alteration and is accompanied by all associated copyright, proprietary and other notices (including this notice) and conditions. Wolfson is not liable for any unauthorised alteration of such information or for any reliance placed thereon.

Any representations made, warranties given, and/or liabilities accepted by any person which differ from those contained in this datasheet or in Wolfson's standard terms and conditions of sale, delivery and payment are made, given and/or accepted at that person's own risk. Wolfson is not liable for any such representations, warranties or liabilities or for any reliance placed thereon by any person.

## ADDRESS

Wolfson Microelectronics plc

Westfield House

26 Westfield Road

Edinburgh

EH11 2QB

Tel :: +44 (0)131 272 7000

Fax :: +44 (0)131 272 7001

Email :: [sales@wolfsonmicro.com](mailto:sales@wolfsonmicro.com)

**REVISION HISTORY**

DATE	REV	ORIGINATOR	CHANGES
08/08/11	4.1	SS	Correction to Audio Interface, Slave Mode specifications. "DACDAT set-up time to BCLK rising edge" specification changed to 20ns minimum.
08/08/11	4.1	PH	All Read-Only and Write-Only registers are specifically identified as Read-Only or Write-Only respectively.
28/09/11	4.2	PH	LIN_VOL and RIN_VOL registers updated; 00000 = -1.55dB