

24-bit, 192kHz Stereo DAC

DESCRIPTION

The WM8729 is a high performance stereo DAC designed for audio applications such as DVD, home theatre systems, and digital TV. The WM8729 supports data input word lengths from 16 to 24-bits and sampling rates up to 192kHz. The WM8729 consists of a serial interface port, digital interpolation filters, multi-bit sigma delta modulators and stereo DAC in a small 16-pin SOIC package.

The WM8729 has a hardware control interface for selection of audio data interface format and de-emphasis.

The WM8729 is an ideal device to interface to AC-3™, DTS™, and MPEG audio decoders for surround sound applications, or for use in DVD players, including supporting the implementation of 2 channels at 192kHz for high-end DVD-Audio applications.

FEATURES

- Stereo DAC
- Audio Performance
 - 106dB SNR ('A' weighted @ 48kHz) DAC
 - -97dB THD
- DAC Sampling Frequency: 8kHz – 192kHz
- Pin Selectable Audio Data Interface Format
 - I²S or Right Justified
- 3.0V - 5.5V Supply Operation
- 16-lead SOIC Package
- Exceeds Dolby Class A Performance Requirements

APPLICATIONS

- DVD-Audio and DVD 'Universal' Players
- Home theatre systems
- Digital TV
- Digital broadcast receivers

BLOCK DIAGRAM

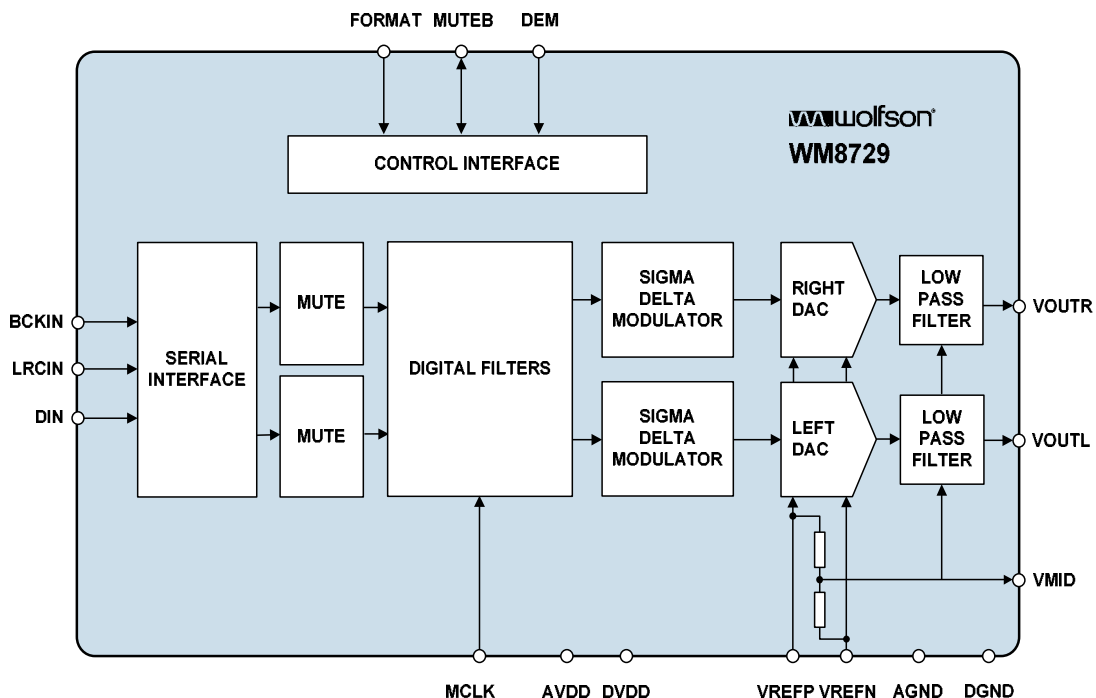
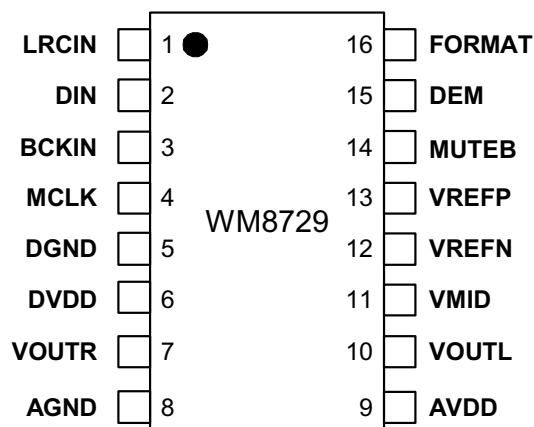

TABLE OF CONTENTS

DESCRIPTION	1
FEATURES	1
APPLICATIONS	1
BLOCK DIAGRAM	1
TABLE OF CONTENTS	2
PIN CONFIGURATION	3
ORDERING INFORMATION	3
PIN DESCRIPTION	4
ABSOLUTE MAXIMUM RATINGS	5
DC ELECTRICAL CHARACTERISTICS	6
ELECTRICAL CHARACTERISTICS	6
TERMINOLOGY	7
MASTER CLOCK TIMING	8
DIGITAL AUDIO INTERFACE	8
DEVICE DESCRIPTION	9
INTRODUCTION	9
CLOCKING SCHEMES	9
DIGITAL AUDIO INTERFACE	9
AUDIO DATA SAMPLING RATES	10
HARDWARE CONTROL MODES	11
DIGITAL FILTER CHARACTERISTICS	13
DAC FILTER RESPONSES.....	13
DIGITAL DE-EMPHASIS CHARACTERISTICS	14
APPLICATIONS INFORMATION	15
RECOMMENDED EXTERNAL COMPONENTS	15
RECOMMENDED EXTERNAL COMPONENTS VALUES	15
RECOMMENDED ANALOGUE LOW PASS FILTER (OPTIONAL)	16
PACKAGE DRAWING	17
IMPORTANT NOTICE	18
ADDRESS:	18

PIN CONFIGURATION



ORDERING INFORMATION

DEVICE	TEMPERATURE RANGE	PACKAGE	MOISTURE SENSITIVITY LEVEL	PEAK SOLDERING TEMPERATURE
WM8729GED/V	-25 to +85°C	16-lead SOIC (Pb-free)	MSL2	260°C
WM8729GED/RV	-25 to +85°C	16-lead SOIC (Pb-free, tape and reel)	MSL2	260°C

Note:

Reel Quantity = 3,000

PIN DESCRIPTION

PIN	NAME	TYPE	DESCRIPTION
1	LRCIN	Digital Input	DAC Sample Rate Clock Input
2	DIN	Digital Input	Serial Audio Data Input
3	BCKIN	Digital Input	Audio Data Bit Clock Input.
4	MCLK	Analogue Input	Master Clock Input
5	DGND	Supply	Digital Ground Supply
6	DVDD	Supply	Digital Positive Supply
7	VOUTR	Analogue Output	Right Channel DAC Output
8	AGND	Supply	Analogue Ground Supply
9	AVDD	Supply	Analogue Positive Supply
10	VOUTL	Analogue Output	Left Channel DAC Output
11	VMID	Analogue Output	Mid Rail Decoupling Point
12	VREFN	Supply	DAC Negative Reference – normally AGND, must not be below AGND
13	VREFP	Supply	DAC Positive Reference – normally AVDD, must not be above AVDD
14	MUTEB	Digital Bi-directional	Mute Control, (L = Mute on, H = Mute off, Z = Automute Enabled)
15	DEM	Digital Input	De-Emphasis Select 0 = De-Emphasis Off 1 = De-Emphasis On
16	FORMAT	Digital Input (Pull-Up)	Digital Audio Data Input Format Selection 0 = Right justified Audio Data 1 = I ² S Audio Data

Note:

Digital input pins have Schmitt trigger input buffers.

ABSOLUTE MAXIMUM RATINGS

Absolute Maximum Ratings are stress ratings only. Permanent damage to the device may be caused by continuously operating at or beyond these limits. Device functional operating limits and guaranteed performance specifications are given under Electrical Characteristics at the test conditions specified.



ESD Sensitive Device. This device is manufactured on a CMOS process. It is therefore generically susceptible to damage from excessive static voltages. Proper ESD precautions must be taken during handling and storage of this device.

Wolfson tests its package types according to IPC/JEDEC J-STD-020B for Moisture Sensitivity to determine acceptable storage conditions prior to surface mount assembly. These levels are:

MSL1 = unlimited floor life at <30°C / 85% Relative Humidity. Not normally stored in moisture barrier bag.

MSL2 = out of bag storage for 1 year at <30°C / 60% Relative Humidity. Supplied in moisture barrier bag.

MSL3 = out of bag storage for 168 hours at <30°C / 60% Relative Humidity. Supplied in moisture barrier bag.

The Moisture Sensitivity Level for each package type is specified in Ordering Information.

CONDITION	MIN	MAX
Digital supply voltage	-0.3V	+7V
Analogue supply voltage	-0.3V	+7V
Voltage range digital inputs	DGND -0.3V	DVDD +0.3V
Voltage range analogue inputs	AGND -0.3V	AVDD +0.3V
Master Clock Frequency		50MHz
Operating temperature range, T _A	-25°C	+85°C
Storage temperature	-65°C	+150°C

Note:

Analogue and digital grounds must always be within 0.3V of each other.

DC ELECTRICAL CHARACTERISTICS

PARAMETER	SYMBOL	TEST CONDITIONS	MIN	TYP	MAX	UNIT
Digital supply range	DVDD		3.0		5.5	V
Analogue supply range	AVDD		3.0		5.5	V
Ground	AGND, DGND			0		V
Difference DGND to AGND			-0.3	0	+0.3	V
Analogue supply current		AVDD = 5V		19		mA
Digital supply current		DVDD = 5V		8		mA
Analogue supply current		AVDD = 3.3V		18		mA
Digital supply current		DVDD = 3.3V		4		mA

ELECTRICAL CHARACTERISTICS

Test Conditions

AVDD, DVDD = 5V, AGND = 0V, DGND = 0V, T_A = +25°C, f_s = 48kHz, MCLK = 256fs unless otherwise stated.

PARAMETER	SYMBOL	TEST CONDITIONS	MIN	TYP	MAX	UNIT
Digital Logic Levels (TTL Levels)						
Input LOW level	V _{IL}				0.8	V
Input HIGH level	V _{IH}		2.0			V
Output LOW	V _{OL}	I _{OL} = 1mA			DGND + 0.3V	V
Output HIGH	V _{OH}	I _{OH} = 1mA	DVDD - 0.3V			V
Analogue Reference Levels						
Reference voltage		VMID	(VREFP - VREFN)/2 - 50mV	(VREFP - VREFN)/2	(VREFP - VREFN)/2 + 50mV	V
Potential divider resistance	R _{VMID}			12k		Ω
DAC Output (Load = 10kΩ, 50pF)						
0dBFS Full scale output voltage		At DAC outputs		1.1 x AVDD/5		V _{rms}
SNR (Note 1,2,3)		A-weighted, @ f _s = 48kHz	100	106		dB
SNR (Note 1,2,3)		A-weighted @ f _s = 96kHz		106		dB
SNR (Note 1,2,3)		A-weighted @ f _s = 192kHz		106		dB
SNR (Note 1,2,3)		A-weighted, @ f _s = 48kHz AVDD, DVDD = 3.3V		105		dB
SNR (Note 1,2,3)		A-weighted @ f _s = 96kHz AVDD, DVDD = 3.3V		103		dB
SNR (Note 1,2,3)		Non 'A' weighted @ f _s = 48kHz		106		dB
THD (Note 1,2,3)		1kHz, 0dBFS		-97		dB
THD+N (Dynamic range, Note 2)		1kHz, -60dBFS	100	106		dB
DAC channel separation				100		dB
Analogue Output Levels						
Output level		Load = 10kΩ, 0dBFS		1.1		V _{RMS}
		Load = 10kΩ, 0dBFS, (AVDD = 3.3V)		0.726		V _{RMS}
Gain mismatch channel-to-channel				±1		%FSR

Test Conditions

AVDD, DVDD = 5V, AGND = 0V, DGND = 0V, T_A = +25°C, f_s = 48kHz, MCLK = 256fs unless otherwise stated.

PARAMETER	SYMBOL	TEST CONDITIONS	MIN	TYP	MAX	UNIT
Minimum resistance load		To midrail or a.c. coupled		1		kΩ
		To midrail or a.c. coupled (AVDD = 3.3V)		600		Ω
Maximum capacitance load		5V or 3.3V		100		pF
Output d.c. level				(VREFP - VREFN)/2		V
Power On Reset (POR)						
POR threshold				2.4		V

Notes:

- Ratio of output level with 1kHz full scale input, to the output level with all zeros into the digital input, measured 'A' weighted over a 20Hz to 20kHz bandwidth.
- All performance measurements done with 20kHz low pass filter, and where noted an A-weight filter. Failure to use such a filter will result in higher THD+N and lower SNR and Dynamic Range readings than are found in the Electrical Characteristics. The low pass filter removes out of band noise; although it is not audible it may affect dynamic specification values.
- VMID decoupled with 10uF and 0.1uF capacitors (smaller values may result in reduced performance).

TERMINOLOGY

- Signal-to-noise ratio (dB) - SNR is a measure of the difference in level between the full scale output and the output with no signal applied. (No Auto-zero or Automute function is employed in achieving these results).
- Dynamic range (dB) - DNR is a measure of the difference between the highest and lowest portions of a signal. Normally a THD+N measurement at 60dB below full scale. The measured signal is then corrected by adding the 60dB to it. (e.g. THD+N @ -60dB= -32dB, DR= 92dB).
- THD+N (dB) - THD+N is a ratio, of the rms values, of (Noise + Distortion)/Signal.
- Stop band attenuation (dB) - Is the degree to which the frequency spectrum is attenuated (outside audio band).
- Channel Separation (dB) - Also known as Cross-Talk. This is a measure of the amount one channel is isolated from the other. Normally measured by sending a full scale signal down one channel and measuring the other.

MASTER CLOCK TIMING

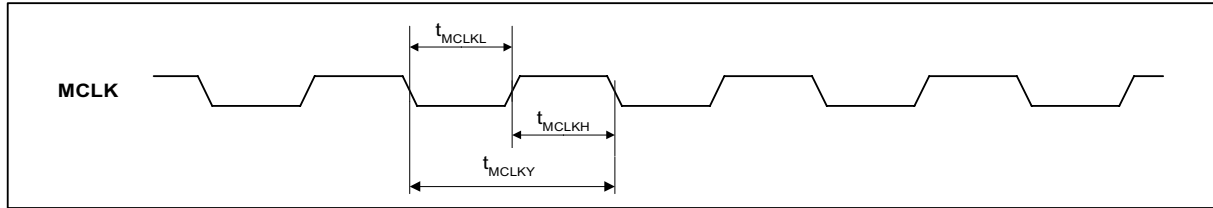

Figure 1 Master Clock Timing Requirements

Test Conditions

AVDD, DVDD = 5V, AGND = 0V, DGND = 0V, $T_A = +25^\circ\text{C}$, $f_s = 48\text{kHz}$, MCLK = 256fs unless otherwise stated.

PARAMETER	SYMBOL	TEST CONDITIONS	MIN	TYP	MAX	UNIT
System Clock Timing Information						
MCLK Master clock pulse width high	t_{MCLKH}		13			ns
MCLK Master clock pulse width low	t_{MCLKL}		13			ns
MCLK Master clock cycle time	t_{MCLKY}		26			ns
MCLK Duty cycle			40:60		60:40	

DIGITAL AUDIO INTERFACE

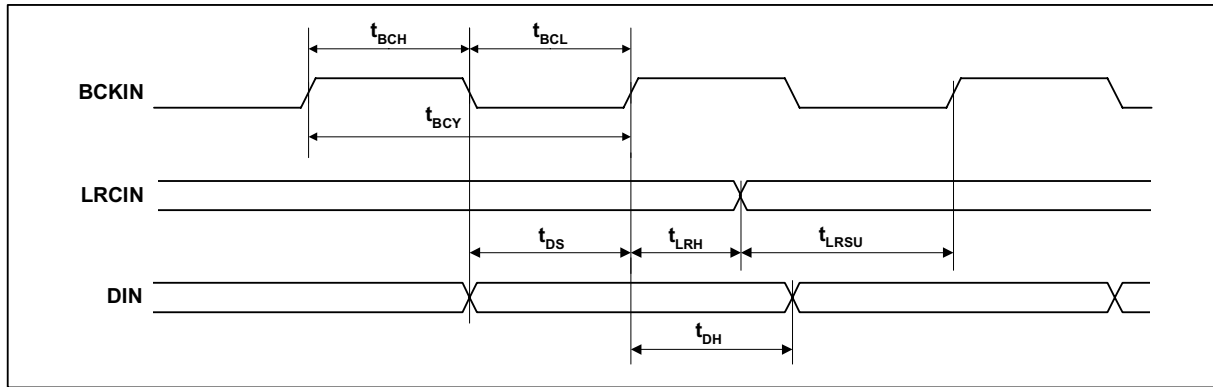

Figure 2 Digital Audio Data Timing

Test Conditions

AVDD, DVDD = 5V, AGND = 0V, AGND, DGND = 0V, $T_A = +25^\circ\text{C}$, $f_s = 48\text{kHz}$, MCLK = 256fs unless otherwise stated.

PARAMETER	SYMBOL	TEST CONDITIONS	MIN	TYP	MAX	UNIT
Audio Data Input Timing Information						
BCKIN cycle time	t_{BCY}		40			ns
BCKIN pulse width high	t_{BCH}		16			ns
BCKIN pulse width low	t_{BCL}		16			ns
LRCIN set-up time to BCKIN rising edge	t_{LRSU}		8			ns
LRCIN hold time from BCKIN rising edge	t_{LRH}		8			ns
DIN set-up time to BCKIN rising edge	t_{DS}		8			ns
DIN hold time from BCKIN rising edge	t_{DH}		8			ns

DEVICE DESCRIPTION

INTRODUCTION

The WM8729 is a high performance DAC designed for digital consumer audio applications. Its range of features make it ideally suited for use in DVD players, AV receivers and other high end consumer audio equipment.

The WM8729 is a complete 2-channel stereo audio digital-to-analogue converter, including digital interpolation filter, multi-bit sigma delta with dither, and switched capacitor multi-bit stereo DAC and output smoothing filters. It is fully compatible and an ideal partner for a range of industry standard microprocessors, controllers and DSPs.

Control of internal functionality of the device is provided by hardware control (pin programmed).

Operation using master clocks of 256fs, 384fs, 512fs or 768fs is provided, selection between clock rates being automatically controlled. Sample rates (fs) from less than 8ks/s to 96ks/s are allowed, provided the appropriate system clock is input. Support is also provided for up to 192ks/s using a master clock of 128fs or 192fs.

The audio data interface supports right justified or I²S (Philips left justified, one bit delayed) interface formats.

The device is packaged in a small 16-pin SOIC.

CLOCKING SCHEMES

In a typical digital audio system there is only one central clock source producing a reference clock to which all audio data processing is synchronised. This clock is often referred to as the audio system's Master Clock. The external master clock can be applied directly through the MCLK input pin with no configuration necessary for sample rate selection.

Note that on the WM8729, MCLK is used to derive clocks for the DAC path. The DAC path consists of DAC sampling clock, DAC digital filter clock and DAC digital audio interface timing. In a system where there are a number of possible sources for the reference clock it is recommended that the clock source with the lowest jitter be used to optimise the performance of the DAC.

DIGITAL AUDIO INTERFACE

Audio data is applied to the internal DAC filters via the Digital Audio Interface. Two popular interface formats are supported:

- Right Justified mode
- I²S mode

Both formats send the MSB first. The WM8729 supports word lengths of 16 or 24 bits in I²S mode and 16 or 20 bits in right justified mode. In right justified and I²S modes, the digital audio interface receives data on the DIN input. Audio Data is time multiplexed with LRCIN indicating whether the left or right channel is present. LRCIN is also used as a timing reference to indicate the beginning or end of the data words.

In right justified and I²S modes, the minimum number of BCKINs per LRCIN period is 2 times the selected word length. LRCIN must be high for a minimum of word length BCKINs and low for a minimum of word length BCKINs. Any mark to space ratio on LRCIN is acceptable provided the above requirements are met.

RIGHT JUSTIFIED MODE

In right justified mode, the LSB is sampled on the rising edge of BCKIN preceding a LRCIN transition. LRCIN is high during the left samples and low during the right samples.

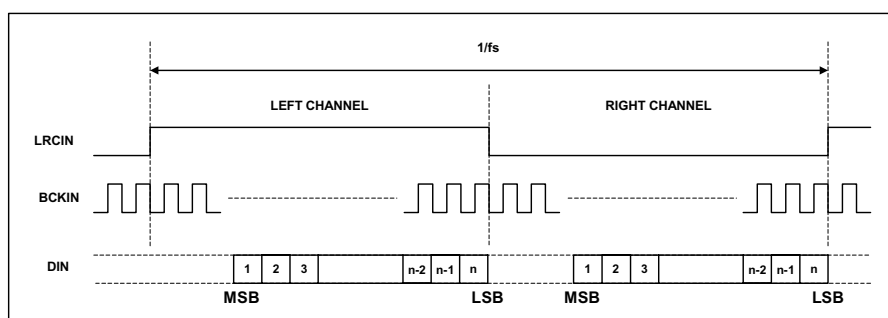

Figure 3 Right Justified Mode Timing Diagram

I²S MODE

In I²S mode, the MSB is sampled on the second rising edge of BCKIN following a LRCIN transition. LRCIN is low during the left samples and high during the right samples.

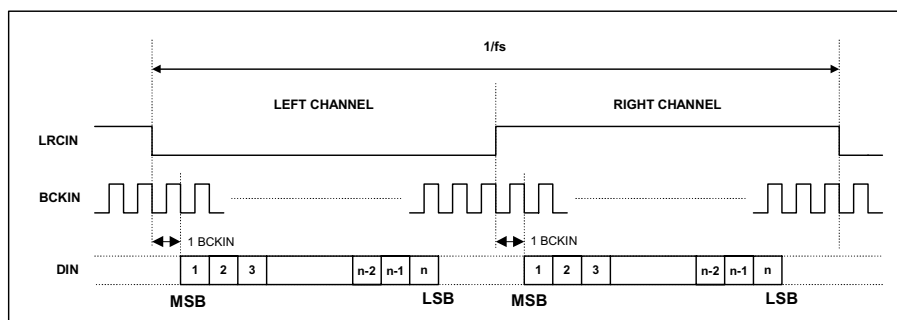

Figure 4 I²S Mode Timing Diagram

AUDIO DATA SAMPLING RATES

The master clock for WM8729 supports audio sampling rates from 128fs to 768fs, where fs is the audio sampling frequency (LRCIN) typically 32kHz, 44.1kHz, 48kHz, 96kHz or 192kHz. The master clock is used to operate the digital filters and the noise shaping circuits.

The WM8729 has a master clock detection circuit that automatically determines the relation between the master clock frequency and the sampling rate (to within +/- 8 master clocks). If there is a greater than 8 clocks error, the interface shuts down the DAC and mutes the output. The master clock should be synchronised with LRCIN, although the WM8729 is tolerant of phase differences or jitter on this clock.

SAMPLING RATE (LRCIN)	MASTER CLOCK FREQUENCY (MHZ) (MCLK)					
	128fs	192fs	256fs	384fs	512fs	768fs
32kHz	4.096	6.144	8.192	12.288	16.384	24.576
44.1kHz	5.6448	8.467	11.2896	16.9340	22.5792	33.8688
48kHz	6.114	9.216	12.288	18.432	24.576	36.864
96kHz	12.288	18.432	24.576	36.864	Unavailable	Unavailable
192kHz	24.576	36.864	Unavailable	Unavailable	Unavailable	Unavailable

Table 1 Master Clock Frequencies Versus Sampling Rate

HARDWARE CONTROL MODES

The WM8729 is hardware programmable providing the user with options to select input audio data format, de-emphasis and mute.

MUTE AND AUTOMUTE OPERATION

Pin 14 (MUTE_B) controls selection of MUTE directly, and can be used to enable and disable the automute function, or as an output of the automuted signal.

MUTE _B PIN	DESCRIPTION
0	Mute DAC channels
1	Normal Operation
Floating	Enable IZD, MUTE _B becomes an output to indicate when IZD occurs.

Table 2 Mute and Automute Control

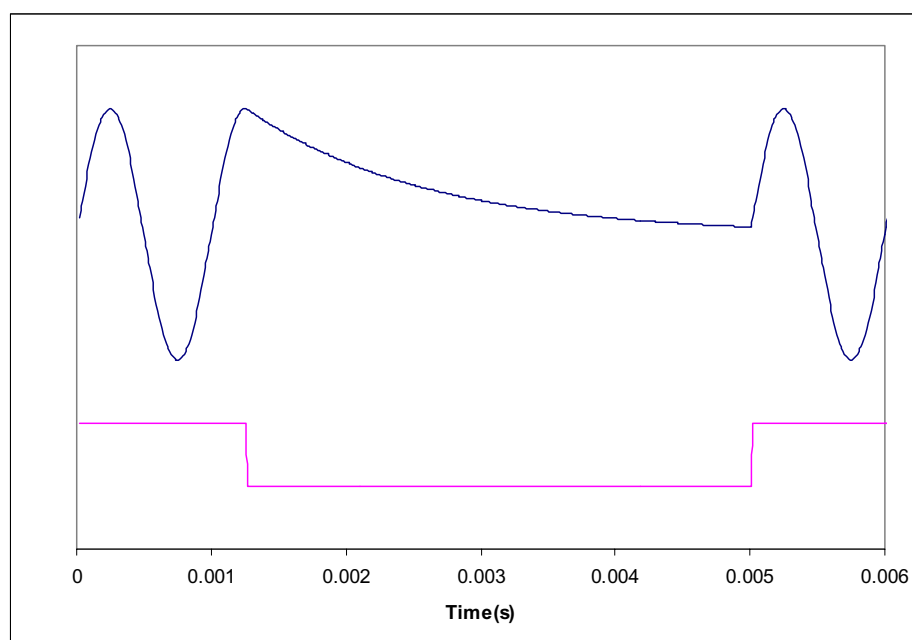

Figure 5 Application and Release of MUTE_B

The MUTE_B pin is an input to select mute or not mute. MUTE_B is active low; taking the pin low causes the filters to soft mute, ramping down the audio signal over a few milliseconds. Taking MUTE_B high again allows data into the filter. Refer to Figure 5.

The Infinite Zero Detect (IZD) function detects a series of zero value audio samples of 1024 samples long being applied to both channels. After such an event, a latch is set whose output (AUTOMUTED) is connected through a 10k Ω resistor to the MUTE_B pin. Thus if the MUTE_B pin is not being driven, the automute function will assert mute.

If MUTE_B is tied high, AUTOMUTED is overridden and will not mute. If MUTE_B is driven from a bi-directional source, then both MUTE and automute functions are available. If MUTE_B is not driven, AUTOMUTED appears as a weak output (10k source impedance) so can be used to drive external mute circuits. AUTOMUTED will be removed as soon as any channel receives a non-zero input.

A diagram showing how the various Mute modes interact is shown below in Figure 6.

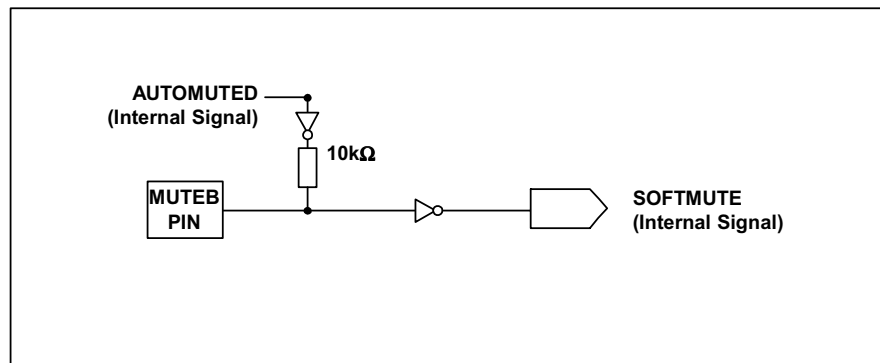

Figure 6 Selection Logic for MUTE Modes

INPUT FORMAT SELECTION

FORMAT (pin 16) controls the data input format.

FORMAT	INPUT DATA MODE
0	20-bit right justified (note 2)
1	24-bit I ² S (note 2)

Table 3 Input Format Selection

Notes:

1. In 24 bit I²S mode, any width of 24 bits or more is supported provided that LRCIN is high for a minimum of 24 BCKINs and low for a minimum of 24 BCKINs, unless Note 2.
2. If exactly 16 BCKIN cycles occur in both the low and high period of LRCIN the WM8729 will assume the data is 16 bit and accept the data accordingly.

DE-EMPHASIS CONTROL

DEM (pin 15) is an input control for selection of de-emphasis filtering to be applied.

DEM	DE-EMPHASIS
0	Off
1	On

Table 4 De-emphasis Control

DIGITAL FILTER CHARACTERISTICS

PARAMETER	SYMBOL	TEST CONDITIONS	MIN	TYP	MAX	UNIT
Passband Edge		-3dB		0.487fs		
Passband Ripple		$f < 0.444fs$			± 0.05	dB
Stopband Attenuation		$f > 0.555fs$	-60			dB

Table 5 Digital Filter Characteristics

DAC FILTER RESPONSES

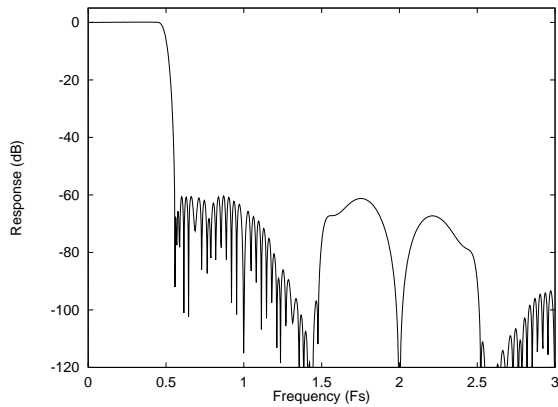

Figure 7 DAC Digital Filter Frequency Response -44.1, 48 and 96kHz

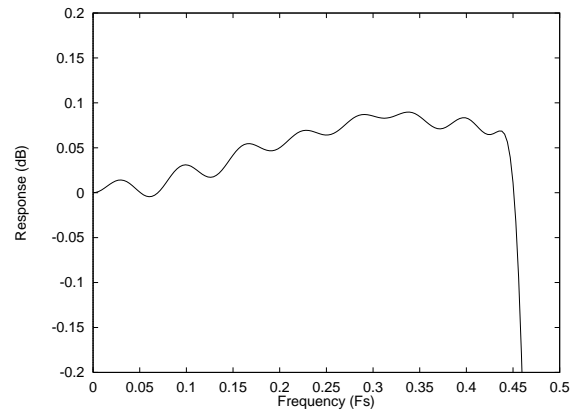

Figure 8 DAC Digital Filter Ripple -44.1, 48 and 96kHz

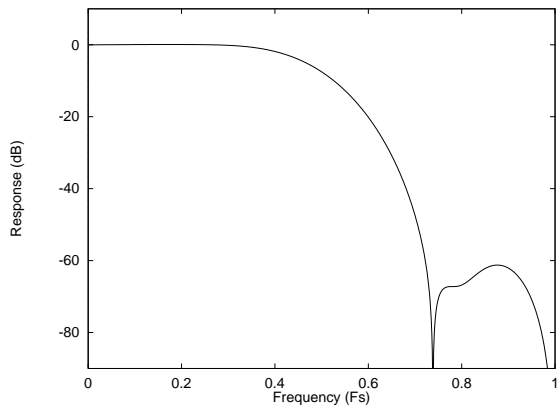

Figure 9 DAC Digital Filter Frequency Response -192kHz

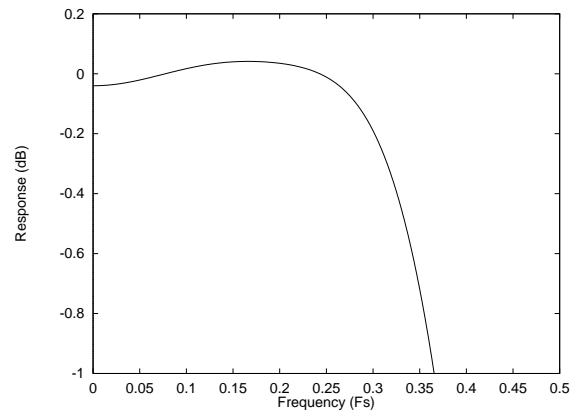

Figure 10 DAC Digital Filter Ripple -192kHz

DIGITAL DE-EMPHASIS CHARACTERISTICS

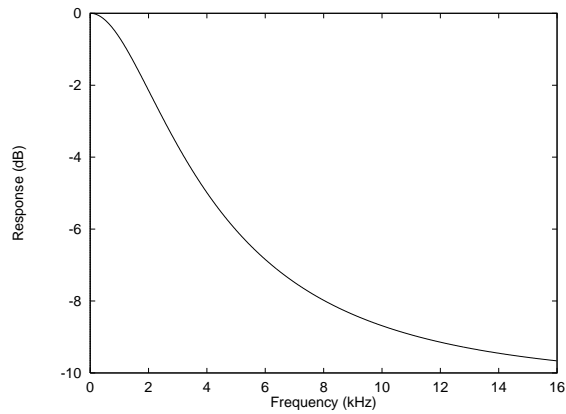

Figure 11 De-Emphasis Frequency Response (32kHz)

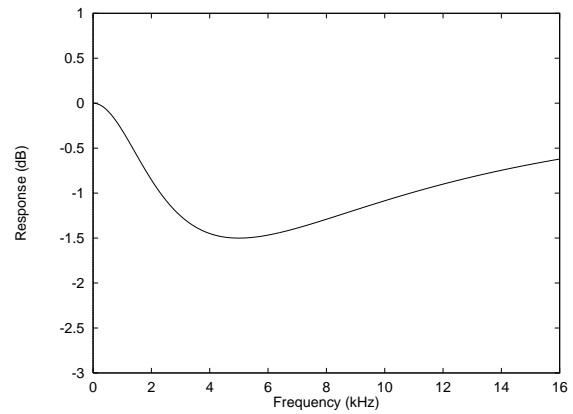

Figure 12 De-Emphasis Error (32kHz)

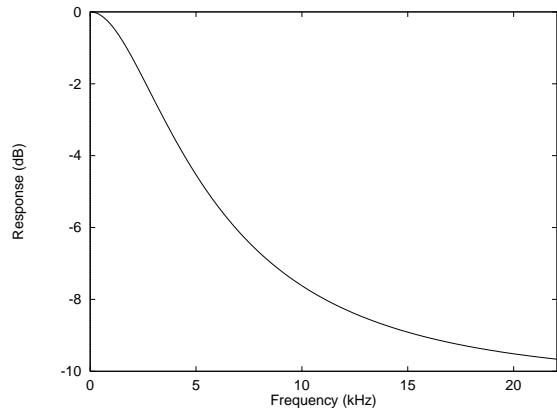

Figure 13 De-Emphasis Frequency Response (44.1kHz)

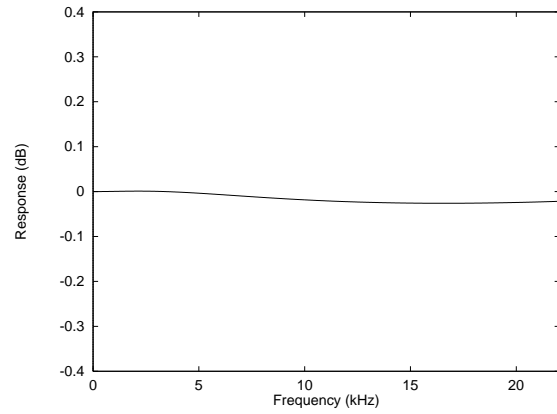

Figure 14 De-Emphasis Error (44.1kHz)

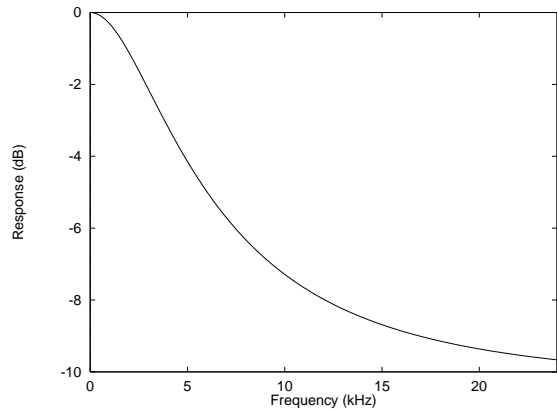

Figure 15 De-Emphasis Frequency Response (48kHz)

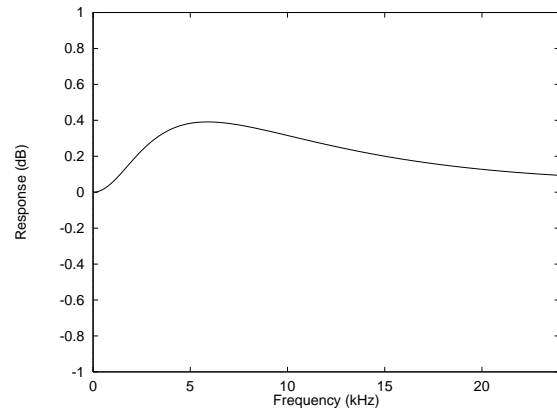

Figure 16 De-Emphasis Error (48kHz)

APPLICATIONS INFORMATION

RECOMMENDED EXTERNAL COMPONENTS

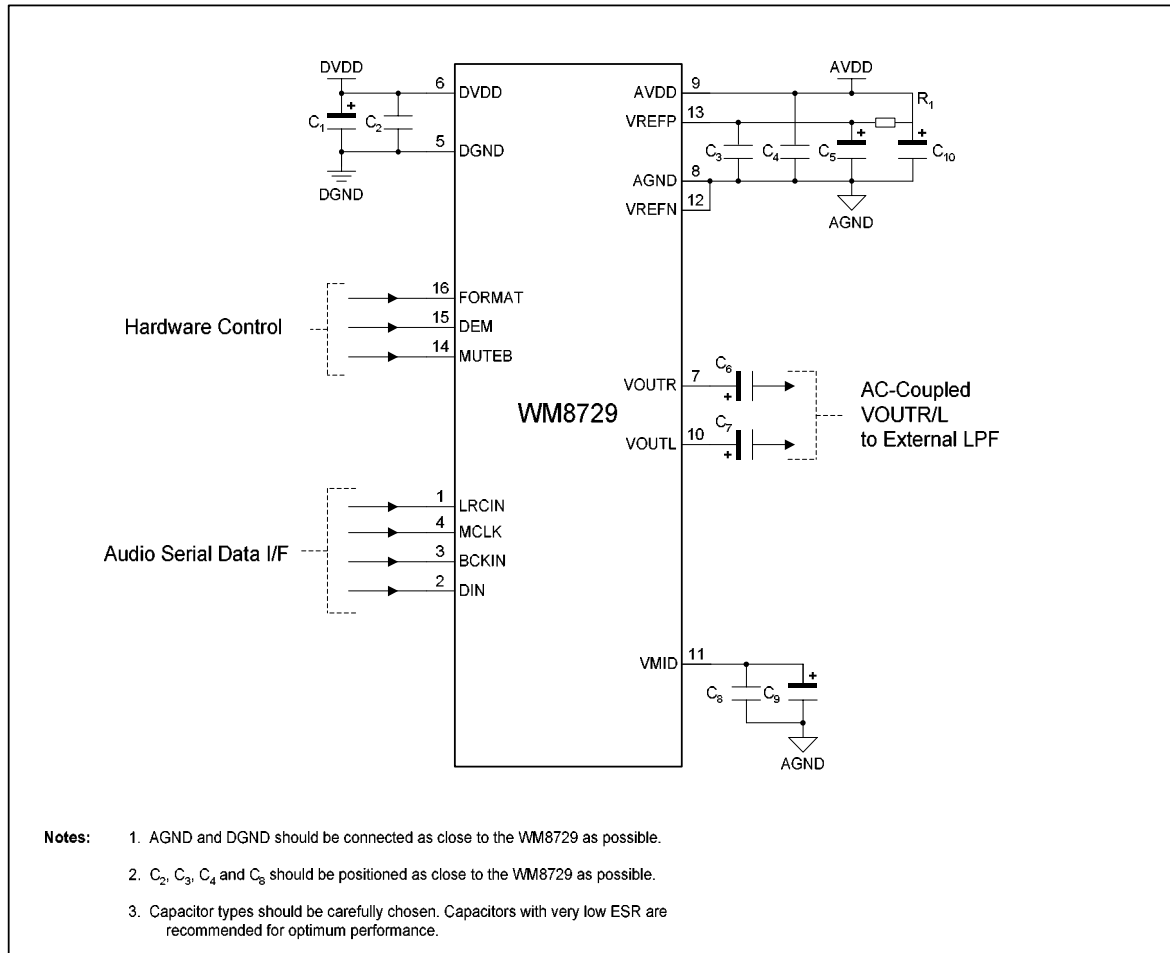

Figure 17 External Component Diagram

RECOMMENDED EXTERNAL COMPONENTS VALUES

COMPONENT REFERENCE	SUGGESTED VALUE	DESCRIPTION
C1 and C5	10µF	De-coupling for DVDD and AVDD/VREFP
C2 to C4	0.1µF	De-coupling for DVDD and AVDD/VREFP
C6 and C7	10µF	Output AC coupling caps to remove midrail DC level from outputs.
C8	0.1µF	Reference de-coupling capacitors for VMID pin.
C9	10µF	
C10	10µF	Filtering for VREFP. Omit if AVDD low noise.
R1	33Ω	Filtering for VREFP. Use 0Ω if AVDD low noise.

Table 6 External Components Description

RECOMMENDED ANALOGUE LOW PASS FILTER (OPTIONAL)

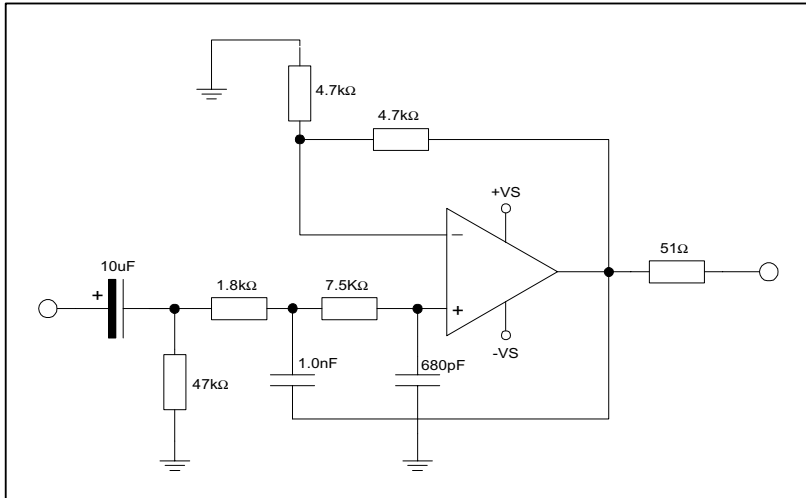
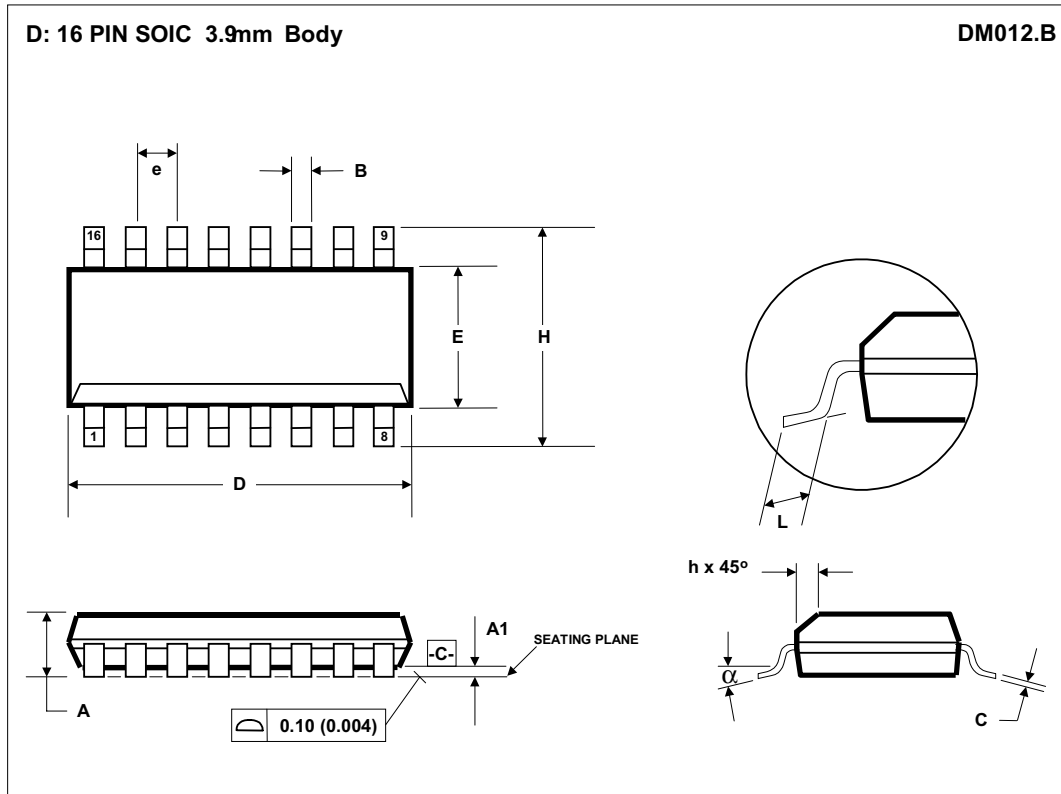

Figure 18 Recommended Low Pass Filter (Optional)

PACKAGE DRAWING



Symbols	Dimensions (mm)		Dimensions (Inches)	
	MIN	MAX	MIN	MAX
A	1.35	1.75	0.0532	0.0688
A1	0.10	0.25	0.0040	0.0098
B	0.33	0.51	0.0130	0.0200
C	0.19	0.25	0.0075	0.0098
D	9.80	10.00	0.3859	0.3937
E	3.80	4.00	0.1497	0.1574
e	1.27 BSC		0.05 BSC	
H	5.80	6.20	0.2284	0.2440
h	0.25	0.50	0.0099	0.0196
L	0.40	1.27	0.0160	0.0500
α	0°	8°	0°	8°
REF:	JEDEC.95, MS-012			

NOTES:
 A. ALL LINEAR DIMENSIONS ARE IN MILLIMETERS (INCHES).
 B. THIS DRAWING IS SUBJECT TO CHANGE WITHOUT NOTICE.
 C. BODY DIMENSIONS DO NOT INCLUDE MOLD FLASH OR PROTRUSION, NOT TO EXCEED 0.25MM (0.010IN).
 D. MEETS JEDEC.95 MS-012, VARIATION = AC. REFER TO THIS SPECIFICATION FOR FURTHER DETAILS.

IMPORTANT NOTICE

Wolfson Microelectronics plc ("Wolfson") products and services are sold subject to Wolfson's terms and conditions of sale, delivery and payment supplied at the time of order acknowledgement.

Wolfson warrants performance of its products to the specifications in effect at the date of shipment. Wolfson reserves the right to make changes to its products and specifications or to discontinue any product or service without notice. Customers should therefore obtain the latest version of relevant information from Wolfson to verify that the information is current.

Testing and other quality control techniques are utilised to the extent Wolfson deems necessary to support its warranty. Specific testing of all parameters of each device is not necessarily performed unless required by law or regulation.

In order to minimise risks associated with customer applications, the customer must use adequate design and operating safeguards to minimise inherent or procedural hazards. Wolfson is not liable for applications assistance or customer product design. The customer is solely responsible for its selection and use of Wolfson products. Wolfson is not liable for such selection or use nor for use of any circuitry other than circuitry entirely embodied in a Wolfson product.

Wolfson's products are not intended for use in life support systems, appliances, nuclear systems or systems where malfunction can reasonably be expected to result in personal injury, death or severe property or environmental damage. Any use of products by the customer for such purposes is at the customer's own risk.

Wolfson does not grant any licence (express or implied) under any patent right, copyright, mask work right or other intellectual property right of Wolfson covering or relating to any combination, machine, or process in which its products or services might be or are used. Any provision or publication of any third party's products or services does not constitute Wolfson's approval, licence, warranty or endorsement thereof. Any third party trade marks contained in this document belong to the respective third party owner.

Reproduction of information from Wolfson datasheets is permissible only if reproduction is without alteration and is accompanied by all associated copyright, proprietary and other notices (including this notice) and conditions. Wolfson is not liable for any unauthorised alteration of such information or for any reliance placed thereon.

Any representations made, warranties given, and/or liabilities accepted by any person which differ from those contained in this datasheet or in Wolfson's standard terms and conditions of sale, delivery and payment are made, given and/or accepted at that person's own risk. Wolfson is not liable for any such representations, warranties or liabilities or for any reliance placed thereon by any person.

ADDRESS:

Wolfson Microelectronics plc
Westfield House
26 Westfield Road
Edinburgh
EH11 2QB
United Kingdom

Tel :: +44 (0)131 272 7000

Fax :: +44 (0)131 272 7001

Email :: sales@wolfsonmicro.com