

24-bit, 192kHz Stereo DAC with Volume Control

DESCRIPTION

The WM8706 is a high performance stereo DAC designed for audio applications such as DVD, home theatre systems, and digital TV. The WM8706 supports data input word lengths from 16 to 32-bits and sampling rates up to 192kHz. The WM8706 can implement 2 channels at 192kHz for high-end DVD-Audio. The WM8706 consists of a serial interface port, digital interpolation filters, multi-bit sigma delta modulators and stereo DAC in a small 28-lead SSOP package. The WM8706 also includes a digitally controllable mute and attenuate function on each channel.

The WM8706 supports a variety of connection schemes for audio DAC control. The MPU serial port provides access to a wide range of features including on-chip mute, attenuation and phase reversal. A hardware controllable interface is also available. It is pin-compatible with the WM8716 provided the oscillator circuit on WM8716 is not required in the application.

The WM8706 is an ideal device to interface to AC-3™, DTS™, and MPEG audio decoders for surround sound applications, or for use in DVD players supporting DVD-A.

FEATURES

- Stereo DAC
- Audio Performance
 - 106dB SNR ('A' weighted @ 48kHz) DAC
 - -97dB THD
- DAC Sampling Frequency: 8kHz – 192kHz
- 3-Wire Serial Control Interface or Hardware Control
- Programmable Audio Data Interface Modes
 - I²S, Left, Right Justified, DSP
 - 16/20/24/32 bit Word Lengths
- Independent Digital Volume Control on Each Channel with 127.5dB Range in 0.5dB Steps
- 3.0V – 5.5V Supply Operation
- 28-Lead SSOP Package
- Exceeds Dolby Class A Performance Requirements

APPLICATIONS

- DVD-Audio and DVD 'Universal' Players
- Home theatre systems
- Digital TV
- Digital broadcast receivers

BLOCK DIAGRAM

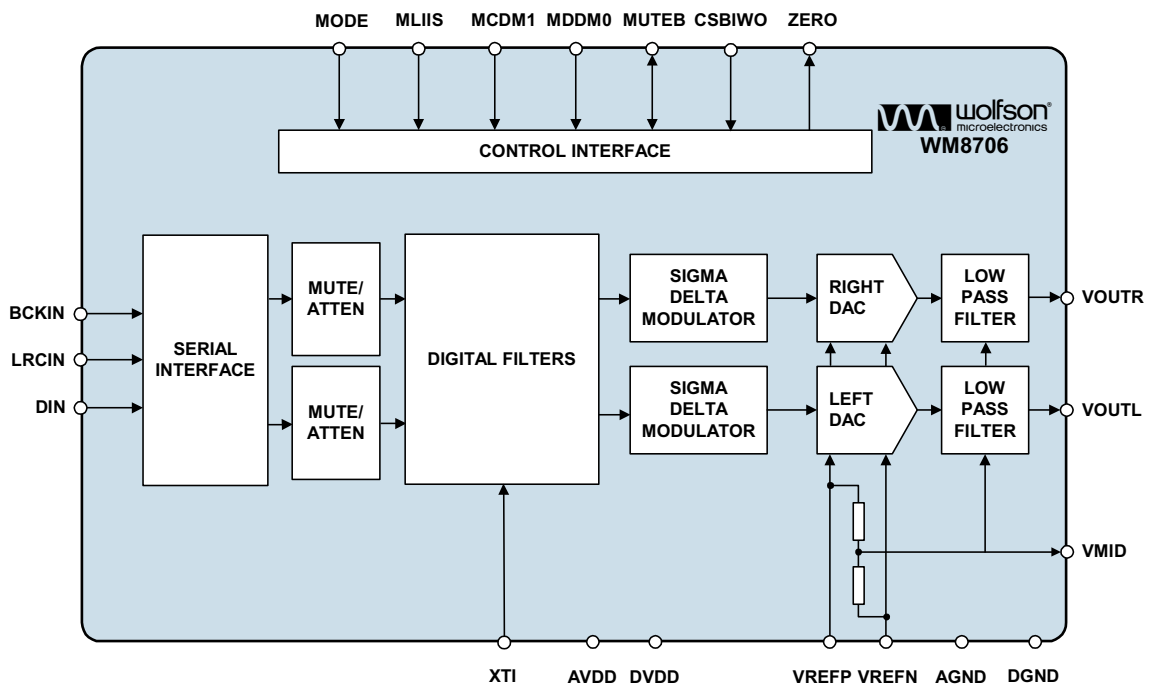

TABLE OF CONTENTS

DESCRIPTION	1
FEATURES	1
APPLICATIONS	1
BLOCK DIAGRAM	1
PIN CONFIGURATION	3
ORDERING INFORMATION	3
PIN DESCRIPTION	4
ABSOLUTE MAXIMUM RATINGS	5
DC ELECTRICAL CHARACTERISTICS	6
ELECTRICAL CHARACTERISTICS	6
TERMINOLOGY	7
MASTER CLOCK TIMING	8
DIGITAL AUDIO INTERFACE	8
MPU INTERFACE TIMING	9
DEVICE DESCRIPTION	10
INTRODUCTION.....	10
CLOCKING SCHEMES	10
DIGITAL AUDIO INTERFACE	10
AUDIO DATA SAMPLING RATES.....	13
HARDWARE CONTROL MODES	13
SOFTWARE CONTROL INTERFACE.....	15
REGISTER MAP	16
ATTENUATION CONTROL.....	18
DIGITAL FILTER CHARACTERISTICS	21
DAC FILTER RESPONSES.....	21
DIGITAL DE-EMPHASIS CHARACTERISTICS	22
RECOMMENDED EXTERNAL COMPONENTS	23
RECOMMENDED EXTERNAL COMPONENT VALUES	23
RECOMMENDED ANALOGUE LOW PASS FILTER (OPTIONAL)	24
PACKAGE DIMENSIONS	25
IMPORTANT NOTICE	26
ADDRESS:	26

PIN CONFIGURATION

LRCIN	<input type="checkbox"/>	1 ●	28	<input type="checkbox"/>	MLIIS
DIN	<input type="checkbox"/>	2	27	<input type="checkbox"/>	MCDM1
BCKIN	<input type="checkbox"/>	3	26	<input type="checkbox"/>	MDDM0
NC	<input type="checkbox"/>	4	25	<input type="checkbox"/>	MUTEB
XTI	<input type="checkbox"/>	5	24	<input type="checkbox"/>	MODE
NC	<input type="checkbox"/>	6	23	<input type="checkbox"/>	CSBIWO
DGND	<input type="checkbox"/>	7	22	<input type="checkbox"/>	NC
DVDD	<input type="checkbox"/>	8	21	<input type="checkbox"/>	ZERO
NC	<input type="checkbox"/>	9	20	<input type="checkbox"/>	VREFP
NC	<input type="checkbox"/>	10	19	<input type="checkbox"/>	VREFN
NC	<input type="checkbox"/>	11	18	<input type="checkbox"/>	VMID
NC	<input type="checkbox"/>	12	17	<input type="checkbox"/>	NC
VOUTR	<input type="checkbox"/>	13	16	<input type="checkbox"/>	VOUTL
AGND	<input type="checkbox"/>	14	15	<input type="checkbox"/>	AVDD

ORDERING INFORMATION

DEVICE	TEMPERATURE RANGE	PACKAGE	MOISTURE SENSITIVITY LEVEL	PEAK SOLDERING TEMPERATURE
WM8706SEDS	-25 to +85°C	28-lead SSOP (lead free)	MSL 1	260°C
WM8706SEDS/R	-25 to +85°C	28-lead SSOP (lead free, tape and reel)	MSL 1	260°C

Note:

Reel quantity = 2,000

PIN DESCRIPTION

PIN	NAME	TYPE	DESCRIPTION
1	LRCIN	Digital Input	DAC Sample Rate Clock Input
2	DIN	Digital Input	Serial Audio Data Input
3	BCKIN	Digital Input	Audio Data Bit Clock Input.
4		NC	No internal connection
5	ZERO	Digital Output (Open Drain)	Infinite ZERO Detect Flag (L=IZD detected, H=IZD not detected)
6		NC	No Internal Connection
7	DGND	Supply	Digital Ground Supply
8	DVDD	Supply	Digital Positive Supply
9		NC	No Internal Connection
10		NC	No Internal Connection
11		NC	No Internal Connection
12		NC	No Internal Connection
13	VOU _{TR}	Analogue Output	Right Channel DAC Output
14	AGND	Supply	Analogue Ground Supply
15	AVDD	Supply	Analogue Positive Supply
16	VOU _{TL}	Analogue Output	Left Channel DAC Output
17		NC	No Internal Connection
18	VMID	Analogue Output	Mid Rail Decoupling Point
19	VREFN	Supply	DAC Negative Reference – normally AGND, must not be below AGND
20	VREFP	Supply	DAC Positive Reference – normally AVDD, must not be above AVDD
21	ZERO	Digital Output	Infinite Zero Detect Flag
22		NC	No Internal Connection
23	CSBIWO	Digital Input	Software Mode: 3-Wire Serial Control Chip Select Hardware Mode: Input Word Length, Pull Up
24	MODE	Digital Input	Control Mode Selection (Low = Hardware, High = Software), Pull Down
25	MUTE _B	Digital Bi-directional	Mute Control (L = Mute on, H = Mute off, Z = Automute Enabled), Pull Up
26	MDDM ₀	Digital Bi-directional	Software Mode: 3-Wire Serial Control Data Input: Hardware Mode: De-Emphasis
27	MCDM ₁	Digital Input	Software Mode: 3-Wire Serial Control Clock Input Hardware Mode: De-Emphasis, Pull Down
28	MLIIS	Digital Input	Software Mode 3-Wire Serial Control Load Input Hardware Mode: Input Data Format Selection, Pull Up

Note:

Digital input pins have Schmitt trigger input buffers.

ABSOLUTE MAXIMUM RATINGS

Absolute Maximum Ratings are stress ratings only. Permanent damage to the device may be caused by continuously operating at or beyond these limits. Device functional operating limits and guaranteed performance specifications are given under Electrical Characteristics at the test conditions specified.



ESD Sensitive Device. This device is manufactured on a CMOS process. It is therefore generically susceptible to damage from excessive static voltages. Proper ESD precautions must be taken during handling and storage of this device.

Wolfson tests its package types according to IPC/JEDEC J-STD-020B for Moisture Sensitivity to determine acceptable storage conditions prior to surface mount assembly. These levels are:

MSL1 = unlimited floor life at <30°C / 85% Relative Humidity. Not normally stored in moisture barrier bag.

MSL2 = out of bag storage for 1 year at <30°C / 60% Relative Humidity. Supplied in moisture barrier bag.

MSL3 = out of bag storage for 168 hours at <30°C / 60% Relative Humidity. Supplied in moisture barrier bag.

The Moisture Sensitivity Level for each package type is specified in Ordering Information.

CONDITION	MIN	MAX
Digital supply voltage	-0.3V	+7V
Analogue supply voltage	-0.3V	+7V
Voltage range digital inputs	DGND -0.3V	DVDD +0.3V
Voltage range analogue inputs	AGND -0.3V	AVDD +0.3V
Master Clock Frequency (XTI)		50MHz
Operating temperature range, T _A	-25°C	+85°C
Storage temperature	-65°C	+150°C

Note:

Analogue and digital grounds must always be within 0.3V of each other.

DC ELECTRICAL CHARACTERISTICS

PARAMETER	SYMBOL	TEST CONDITIONS	MIN	TYP	MAX	UNIT
Digital supply range	DVDD		3.0		5.5	V
Analogue supply range	AVDD		3.0		5.5	V
Ground	AGND, DGND			0		V
Difference DGND to AGND			-0.3	0	+0.3	V
Analogue supply current		AVDD = 5V		19		mA
Digital supply current		DVDD = 5V		8		mA
Analogue supply current		AVDD = 3.3V		18		mA
Digital supply current		DVDD = 3.3V		4		mA

ELECTRICAL CHARACTERISTICS**Test Conditions**

AVDD, DVDD = 5V, AGND, DGND = 0V, T_A = +25°C, f_s = 48kHz, XT1 = 256fs unless otherwise stated.

PARAMETER	SYMBOL	TEST CONDITIONS	MIN	TYP	MAX	UNIT
Digital Logic Levels (TTL Levels)						
Input LOW level	V _{IL}				0.8	V
Input HIGH level	V _{IH}		2.0			V
Output LOW	V _{OL}	I _{OL} = 1mA			AGND + 0.3V	V
Output HIGH	V _{OH}	I _{OH} = 1mA	AVDD - 0.3V			V
Analogue Reference Levels						
Reference voltage		VMID	(VREFP - VREFN)/2 - 50mV	(VREFP - VREFN)/2	(VREFP - VREFN)/2 + 50mV	V
Potential divider resistance	R _{VMID}			10k		Ω
DAC Output (Load = 10K Ω. 50pF)						
0dBfs Full scale output voltage		At DAC outputs		1.1 x AVDD/5		V _{rms}
SNR (Note 1,2,3)		A-weighted, @ f _s = 48kHz	100	106		dB
SNR (Note 1,2,3)		A-weighted @ f _s = 96kHz		106		dB
SNR (Note 1,2,3)		A-weighted @ f _s = 192kHz		106		dB
SNR (Note 1,2,3)		A-weighted, @ f _s = 48kHz AVDD, DVDD = 3.3V		102		dB
SNR (Note 1,2,3)		A-weighted @ f _s = 96kHz AVDD, DVDD = 3.3V		102		dB
SNR (Note 1,2,3)		Non 'A' weighted @ f _s = 48kHz		103		dB
THD (Note 1,2,3)		1kHz, 0dBfs		-97		dB
THD+N (Dynamic range, Note 2)		1kHz, -60dBfs	100	106		dB
DAC channel separation				100		dB

Test ConditionsAVDD, DVDD = 5V, AGND, DGND = 0V, T_A = +25°C, f_s = 48kHz, XT1 = 256fs unless otherwise stated.

PARAMETER	SYMBOL	TEST CONDITIONS	MIN	TYP	MAX	UNIT
Analogue Output Levels						
Output level		Load = 10k Ω, 0dBFS		1.1		V _{RMS}
		Load = 10k Ω, 0dBFS, (AVDD = 3.3V)		0.726		V _{RMS}
Gain mismatch channel-to-channel				±1		%FSR
Minimum resistance load		To midrail or a.c. coupled		1		kΩ
		To midrail or a.c. coupled (AVDD = 3.3V)		600		Ω
Maximum capacitance load		5V or 3.3V		100		pF
Output d.c. level				(VREFP - VREFN)/2		V
Power On Reset (POR)						
POR threshold				2.4		V

Notes:

- Ratio of output level with 1kHz full scale input, to the output level with all zeros into the digital input, measured 'A' weighted over a 20Hz to 20kHz bandwidth.
- All performance measurements done with 20kHz low pass filter, and where noted an A-weight filter. Failure to use such a filter will result in higher THD+N and lower SNR and Dynamic Range readings than are found in the Electrical Characteristics. The low pass filter removes out of band noise; although it is not audible it may affect dynamic specification values.
- VMID decoupled with 10uF and 0.1uF capacitors (smaller values may result in reduced performance).

TERMINOLOGY

- Signal-to-noise ratio (dB) - SNR is a measure of the difference in level between the full scale output and the output with no signal applied. (No Auto-zero or Automute function is employed in achieving these results).
- Dynamic range (dB) - DNR is a measure of the difference between the highest and lowest portions of a signal. Normally a THD+N measurement at 60dB below full scale. The measured signal is then corrected by adding the 60dB to it. (e.g. THD+N @ -60dB = -32dB, DR = 92dB).
- THD+N (dB) - THD+N is a ratio, of the rms values, of (Noise + Distortion)/Signal.
- Stop band attenuation (dB) - Is the degree to which the frequency spectrum is attenuated (outside audio band).
- Channel Separation (dB) - Also known as Cross-Talk. This is a measure of the amount one channel is isolated from the other. Normally measured by sending a full scale signal down one channel and measuring the other.

MASTER CLOCK TIMING

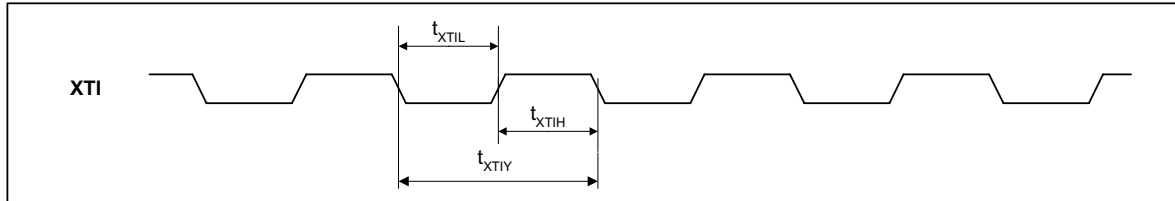

Figure 1 Master Clock Timing Requirements

Test Conditions

AVDD, DVDD = 5V, AGND, DGND = 0V, $T_A = +25^\circ\text{C}$, $f_s = 48\text{kHz}$, XTI = 256fs unless otherwise stated.

PARAMETER	SYMBOL	TEST CONDITIONS	MIN	TYP	MAX	UNIT
Master Clock Timing Information						
XTI Master clock pulse width high	t_{XTIH}		13			ns
XTI Master clock pulse width low	t_{XTIL}		13			ns
XTI Master clock cycle time	t_{XTIY}		26			ns
XTI Duty cycle			40:60		60:40	

DIGITAL AUDIO INTERFACE

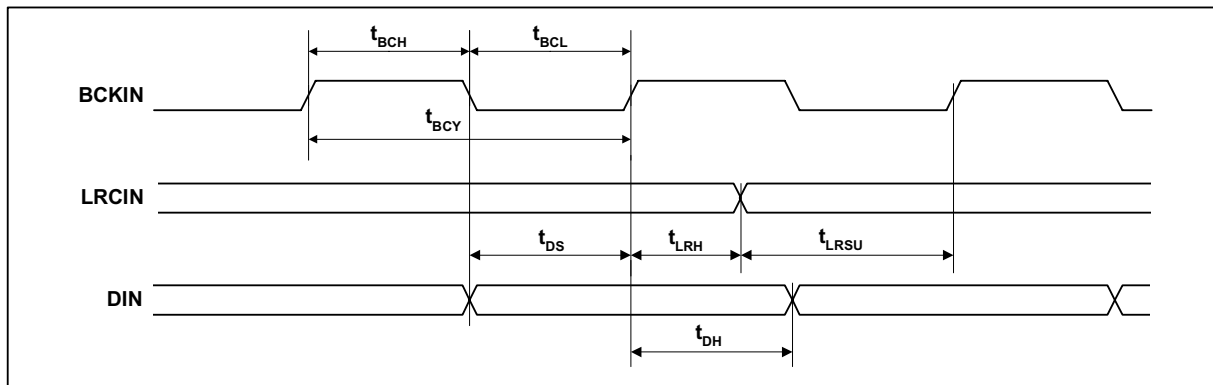

Figure 2 Digital Audio Data Timing

Test Conditions

AVDD, DVDD = 5V, AGND, DGND = 0V, $T_A = +25^\circ\text{C}$, $f_s = 48\text{kHz}$, XTI = 256fs unless otherwise stated.

PARAMETER	SYMBOL	TEST CONDITIONS	MIN	TYP	MAX	UNIT
Audio Data Input Timing Information						
BCKIN cycle time	t_{BCY}		40			ns
BCKIN pulse width high	t_{BCH}		16			ns
BCKIN pulse width low	t_{BCL}		16			ns
LRCIN set-up time to BCKIN rising edge	t_{LRSU}		8			ns
LRCIN hold time from BCKIN rising edge	t_{LRH}		8			ns
DIN set-up time to BCKIN rising edge	t_{DS}		8			ns
DIN hold time from BCKIN rising edge	t_{DH}		8			ns

MPU INTERFACE TIMING

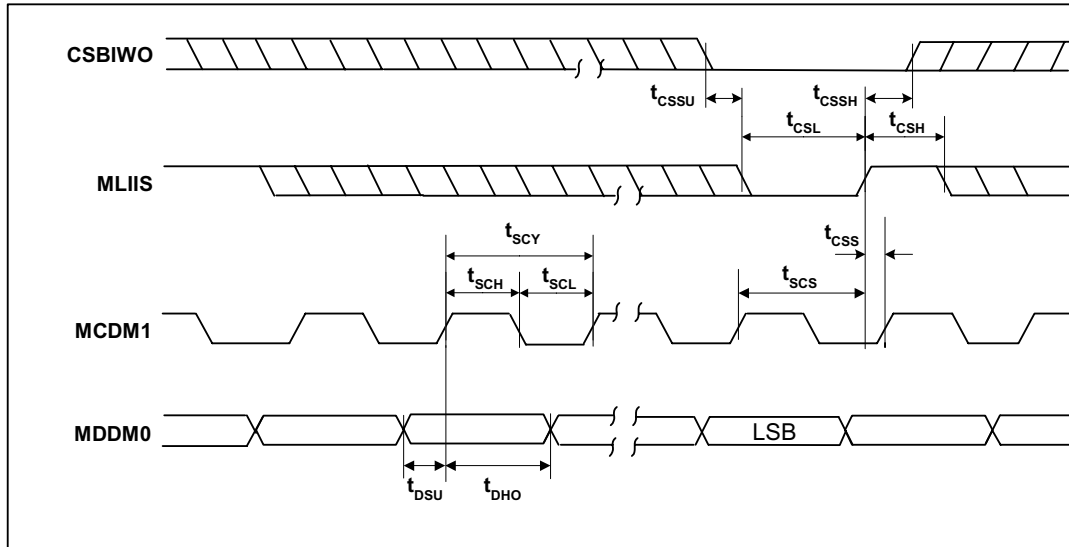

Figure 3 Program Register Input Timing - 3-Wire Serial Control Mode

Test Conditions

AVDD, DVDD = 5V, AGND, DGND = 0V, T_A = +25°C, f_s = 48kHz, XT1 = 256fs unless otherwise stated.

PARAMETER	SYMBOL	TEST CONDITIONS	MIN	TYP	MAX	UNIT
Program Register Input Information						
MCDM1 rising edge to MLIIS rising edge	t _{SCS}		40			ns
MCDM1 pulse cycle time	t _{SCY}		80			ns
MCDM1 pulse width low	t _{SCL}		20			ns
MCDM1 pulse width high	t _{SCH}		20			ns
MDDM0 to MCDM1 set-up time	t _{DSU}		20			ns
MCDM1 to MDDM0 hold time	t _{DHO}		20			ns
MLIIS pulse width low	t _{CSL}		20			ns
MLIIS pulse width high	t _{CSH}		20			ns
MLIIS rising to SCLK rising	t _{CSS}		20			ns
CSBIWO to MLIIS set-up time	t _{CSSU}		20			Ns
MLIIS to CSBIWO hold time	t _{CSSH}		20			ns

DEVICE DESCRIPTION

INTRODUCTION

The WM8706 is a high performance DAC designed for digital consumer audio applications. Its range of features make it ideally suited for use in DVD players, AV receivers and other high end consumer audio equipment.

The WM8706 is a complete 2-channel stereo audio digital-to-analogue converter, including digital interpolation filter, multi-bit sigma delta with dither, and switched capacitor multi-bit stereo DAC and output smoothing filters. The WM8706 includes an on-board digital volume control, configurable digital audio interface and a 3 wire MPU control interface. It is fully compatible and an ideal partner for a range of industry standard microprocessors, controllers and DSPs.

Control of internal functionality of the device is by either hardware control (pin programmed) or software control (3-wire serial control interface). The MODE pin selects between hardware and software control. The software control interface may be asynchronous to the audio data interface. Control data will be re-synchronised to the audio processing internally.

Operation using master clocks of 256fs, 384fs, 512fs or 768fs is provided, selection between clock rates being automatically controlled in hardware mode, or serial controlled when in software mode. Sample rates (fs) from less than 8ks/s to 96ks/s are allowed, provided the appropriate master clock is input. Support is also provided for up to 192ks/s using a master clock of 128fs or 192fs.

The audio data interface supports right, left and I²S (Philips left justified, one bit delayed) interface formats along with a highly flexible DSP serial port interface. When in hardware mode, the three serial interface pins become control pins to allow selection of input data format type (I²S or right justified), input word length (16, 20, or 24-bit) and de-emphasis functions.

The device is packaged in a small 28-pin SSOP and is a pin-compatible alternative to the WM8716.

CLOCKING SCHEMES

In a typical digital audio system there is only one central clock source producing a reference clock to which all audio data processing is synchronised. This clock is often referred to as the audio system's Master Clock. The external master system clock can be applied directly through the XTI input pin with no software configuration necessary for sample rate selection.

Note that on the WM8706, XTI is used to derive clocks for the DAC path. The DAC path consists of DAC sampling clock, DAC digital filter clock and DAC digital audio interface timing. In a system where there are a number of possible sources for the reference clock it is recommended that the clock source with the lowest jitter be used to optimise the performance of the DAC.

DIGITAL AUDIO INTERFACE

Audio data is applied to the internal DAC filters via the Digital Audio Interface. 5 popular interface formats are supported:

- Left Justified mode
- Right Justified mode
- I²S mode
- DSP Early mode
- DSP Late mode

All 5 formats send the MSB first and support word lengths of 16, 20, 24 and 32 bits. The exception is that 32 bit data is not supported in right justified mode. DIN and LRCIN are sampled on the rising, or falling edge of BCKIN depending on the format selected.

In left justified, right justified and I²S modes, the digital audio interface receives data on the DIN input. Audio Data is time multiplexed with LRCIN indicating whether the left or right channel is present. LRCIN is also used as a timing reference to indicate the beginning or end of the data words.

In left justified, right justified and I²S modes, the minimum number of BCKINs per LRCIN period is 2 times the selected word length. LRCIN must be high for a minimum of word length BCKINs and low for a minimum of word length BCKINs. Any mark to space ratio on LRCIN is acceptable provided the above requirements are met. The WM8706 will automatically detect when data with a LRCIN period of exactly 32 is sent, and select 16 bit mode - overriding any previously programmed word length. Word length will revert to the previously programmed value when a LRCIN period other than 32 is detected. (see Figure 4, Figure 5 and Figure 6).

In DSP early or DSP late mode, the data is time multiplexed onto DIN. LRCIN is used as a frame sync signal to identify the MSB of the first word. The minimum number of BCKINs per LRCIN period is 2 times the selected word length. Any mark to space ratio is acceptable on LRCIN provided the rising edge is correctly positioned (see Figure 7 and Figure 8).

LEFT JUSTIFIED MODE

In left justified mode, the MSB is sampled on the first rising edge of BCKIN following a LRCIN transition. LRCIN is high during the left samples and low during the right samples.

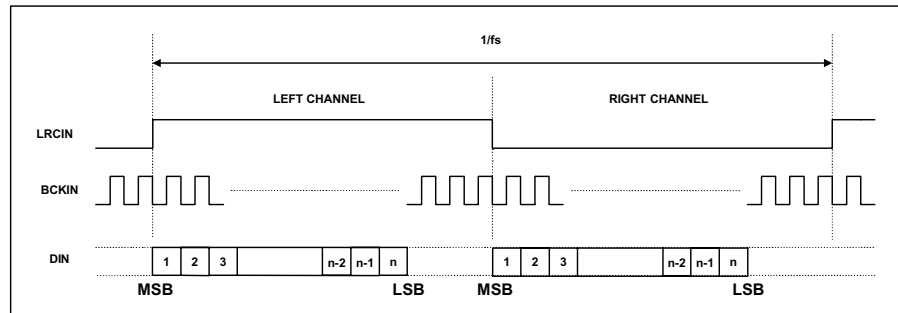

Figure 4 Left Justified Mode Timing Diagram

RIGHT JUSTIFIED MODE

In right justified mode, the LSB is sampled on the rising edge of BCKIN preceding a LRCIN transition. LRCIN is high during the left samples and low during the right samples.

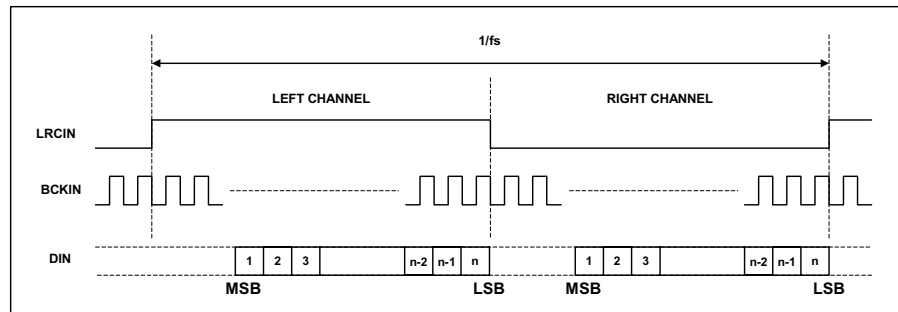

Figure 5 Right Justified Mode Timing Diagram

I²S MODE

In I²S mode, the MSB is sampled on the second rising edge of BCKIN following a LRCIN transition. LRCIN is low during the left samples and high during the right samples.

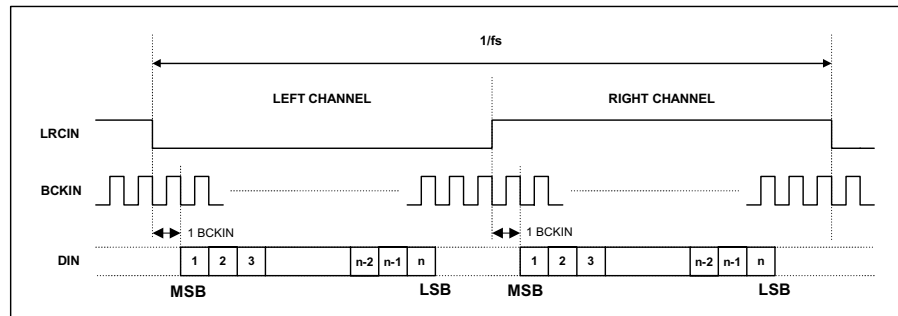

Figure 6 I²S Mode Timing Diagram

DSP EARLY MODE

In DSP early mode, the first bit is sampled on the BCKIN rising edge following the one which detects a low to high transition on LRCIN. No BCKIN edges are allowed between the data words. The word order is DIN left, DIN right.

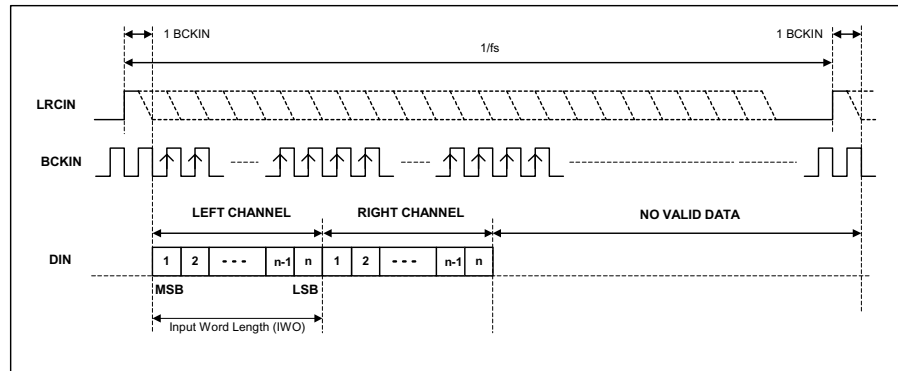

Figure 7 DSP Early Mode Timing Diagram

DSP LATE MODE

In DSP late mode, the first bit is sampled on the BCKIN rising edge which detects a low to high transition on LRCIN. No BCKIN edges are allowed between the data words. The word order is DIN left, DIN right.

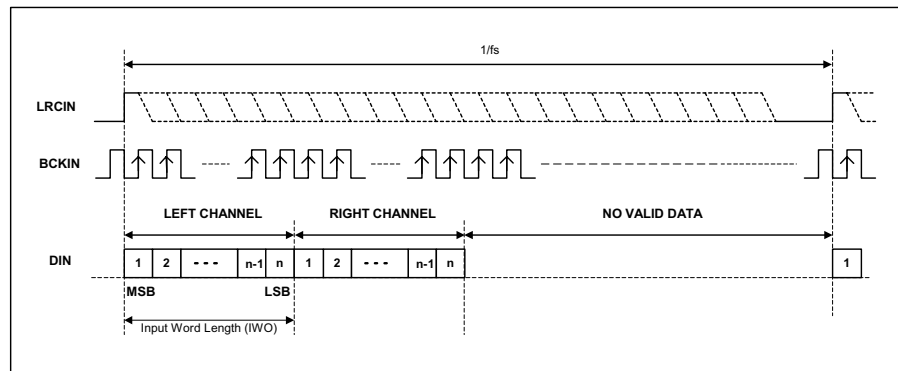

Figure 8 DSP Late Mode Timing Diagram

AUDIO DATA SAMPLING RATES

The master clock for WM8706 supports audio sampling rates from 128fs to 768fs, where fs is the audio sampling frequency (LRCIN) typically 32kHz, 44.1kHz, 48kHz, 96kHz or 192kHz. The master clock is used to operate the digital filters and the noise shaping circuits.

The WM8706 has a master clock detection circuit that automatically determines the relation between the master clock frequency and the sampling rate (to within +/- 32 master clocks). If there is a greater than 8 clocks error, the interface shuts down the DAC and mutes the output. The master clock should be synchronised with LRCIN, although the WM8706 is tolerant of phase differences or jitter on this clock.

SAMPLING RATE (LRCIN)	MASTER CLOCK FREQUENCY (MHZ) (XTI)					
	128fs	192fs	256fs	384fs	512fs	768fs
32kHz	4.096	6.144	8.192	12.288	16.384	24.576
44.1kHz	5.6448	8.467	11.2896	16.9340	22.5792	33.8688
48kHz	6.114	9.216	12.288	18.432	24.576	36.864
96kHz	12.288	18.432	24.576	36.864	Unavailable	Unavailable
192kHz	24.576	36.864	Unavailable	Unavailable	Unavailable	Unavailable

Table 1 Typical Relationships Between System Frequency and Sampling Rates.

HARDWARE CONTROL MODES

When the MODE pin is held low, the following hardware modes of operation are available.

MUTE AND AUTOMUTE OPERATION

In both hardware and software modes, pin 25 (MUTEB) controls selection of MUTE directly, and can be used to enable and disable the automute function. Automute is enabled by leaving MUTEB pin floating, it is disabled by applying a signal to the pin. When left floating this pin becomes an output and indicates infinite ZERO detect (IZD), see also pin 5 (ZERO). The status of IZD controls the selection of MUTE when automute is enabled. When IZD is detected MUTE is enabled and when IZD is not detected MUTE is disabled.

MUTEB PIN	DESCRIPTION
0	Mute DAC channels
1	Normal Operation
Floating	Enable IZD, MUTEB becomes an output to indicate when IZD occurs.

Table 2 Mute and Automute Control

ZERO PIN	DESCRIPTION
0	Indicates Infinite Zero detected from the digital input.
1	Indicates Infinite Zero not detected from the digital input.

Table 3 Zero Pin Output

Figure 9 shows the application and release of MUTE whilst a full amplitude sinusoid is being played at 48kHz sampling rate. When MUTE (lower trace) is asserted, the output (upper trace) begins to decay exponentially from the DC level of the last input sample. The output will decay towards V_{MID} with a time constant of approximately 64 input samples. When MUTE is deasserted, the output will restart almost immediately from the current input sample.

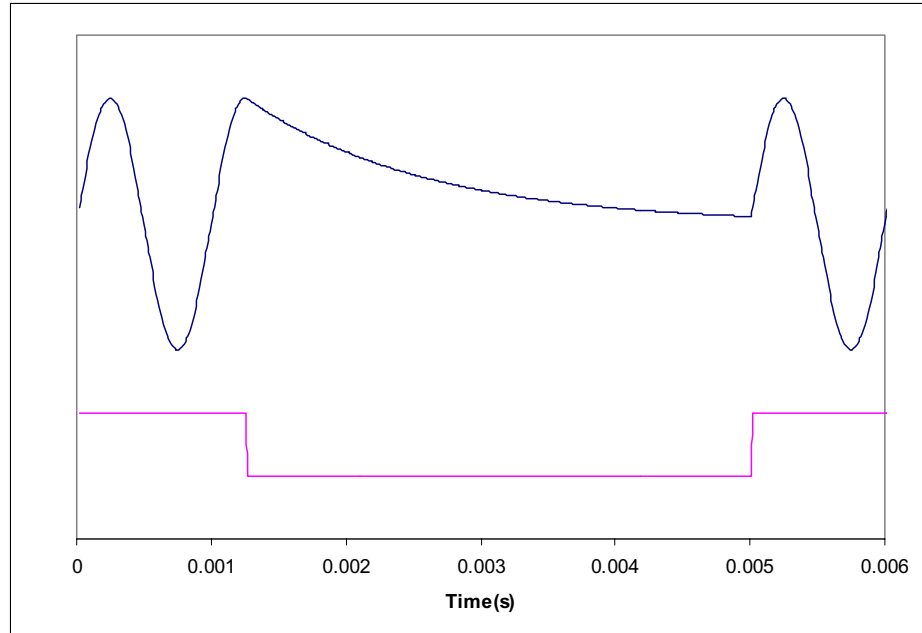

Figure 9 Application and Release of Soft Mute

The MUTEB pin is an input to select mute or not mute. MUTEB is active low; taking the pin low causes the filters to soft mute, ramping down the audio signal over a few milliseconds. Taking MUTEB high again allows data into the filter.

The automute function detects a series of zero value audio samples of 1024 samples long being applied to both channels. After such an event, a latch is set whose output (AUTOMUTED) is wire OR'ed through a 10kohm resistor to the MUTEB pin. Thus if the MUTEB pin is not being driven, the automute function will assert mute.

If MUTEB is tied high, AUTOMUTE is overridden and will not mute unless the IZD register bit is set. If MUTEB is driven from a bi-directional source, then both MUTE and automute functions are available. If MUTEB is not driven, AUTOMUTED appears as a weak output (10k source impedance) so can be used to drive external mute circuits. Automute will be removed as soon as any channel receives a non-zero input.

A diagram showing how the various Mute modes interact is shown below in Figure 10.

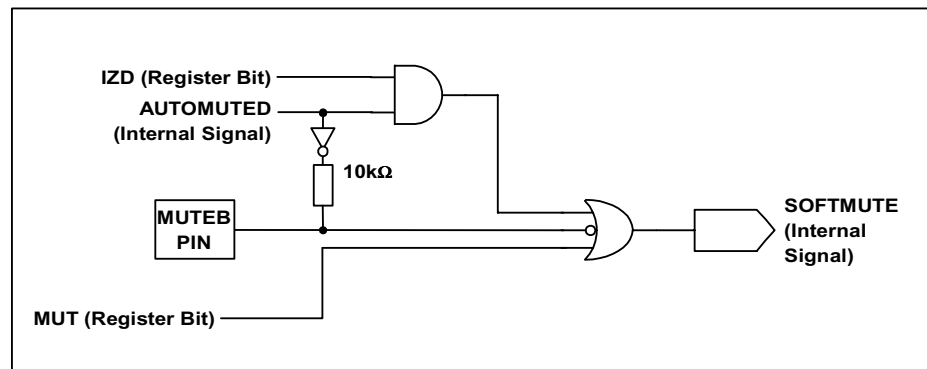

Figure 10 Selection Logic for MUTE Modes

INPUT FORMAT SELECTION

In hardware mode, MLIIS (pin 28) and CSBIWO (pin 23) become input controls for selection of input data format type and input data word length.

MLIIS	CSBIWO	INPUT DATA MODE
0	0	24-bit right justified**
0	1	20-bit right justified
1	0	16-bit I ² S
1	1	24-bit I ² S

Table 4 Input Format Selection

Note:

In 24 bit I²S mode, any width of 24 bits or less is supported provided that LRCIN is high for a minimum of 24 BCKINs and low for a minimum of 24 BCKINs.

** This mode differs from the WM8716 which does 16-bit right justified in this mode. The previous mode is still available by using exactly 32 BCKIN per LRCIN cycle, 16 for left and right. This mode is automatically detected within the hardware and overrides the data width specified but **not** the format.

DE-EMPHASIS CONTROL

In hardware mode, MCDM1 (pin 27) and MDDM0 (pin 26) become input controls for selection of de-emphasis filtering to be applied.

MCDM1	MDDM0	DE-EMPHASIS**
0	0	Off
0	1	48kHz
1	0	44.1kHz
1	1	32kHz

Table 5 De-emphasis Control

Note:

** The actual de-emphasis within the WM8706 is the same for all data rates. This differs from WM8716 which has a different response for each sample rate.

SOFTWARE CONTROL INTERFACE

SELECTION OF CONTROL MODE

The WM8706 may be programmed to operate in hardware or software control modes. This is achieved by setting the state of the MODE pin.

MODE	INTERFACE FORMAT
0	Hardware Control Mode
1	Software Control Mode

Table 6 Control Interface Mode Selection

3-WIRE (SPI COMPATIBLE) SERIAL CONTROL MODE

The WM8706 can be controlled using a 3-wire serial interface. MDDM0 is used for the program data, MCDM1 is used to clock in the program data and MLIIS is used to latch in the program data. The 3-wire interface protocol is shown in Figure 11.

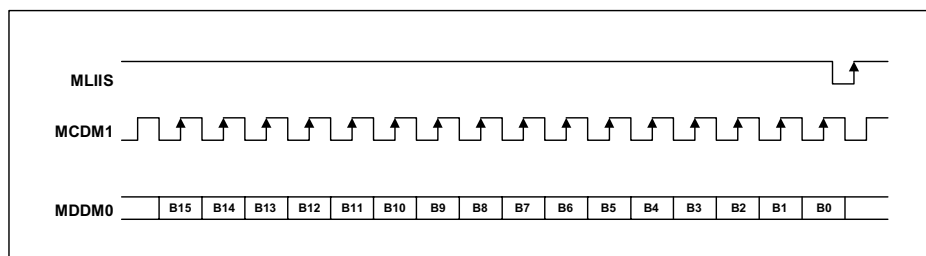

Figure 11 3-Wire Serial Interface

Notes:

1. B[15:9] are Control Address Bits
2. B[8:0] are Control Data Bits

REGISTER MAP

WM8706 uses a total of 4 programme registers, which are 16-bits long. These registers are all loaded through input pin MDDM0. After the 16 data bits are clocked in, MLIIS is used to latch in the data to the appropriate register. Table 7 shows the complete mapping of the 4 registers.

	B15	B14	B13	B12	B11	B10	B9	B8	B7	B6	B5	B4	B3	B2	B1	B0
M0	0	0	0	0	0	0	0	UPDATEL	LAT7	LAT6	LAT5	LAT4	LAT3	LAT2	LAT1	LAT0
M1	0	0	0	0	0	0	1	UPDATER	RAT7	RAT6	RAT5	RAT4	RAT3	RAT2	RAT1	RAT0
M2	0	0	0	0	0	1	0	0	0	0	IW2	IW1	IW0	PWRDN	DEEMPH	MUT
M3	0	0	0	0	0	1	1	IZD	SF1	SF0	BCP	REV	0	ATC	LRP	I ² S
	ADDRESS							DATA								

Table 7 Mapping of Program Registers

REGISTER ADDRESS A2, A1, A0	BITS	LABEL	DEFAULT	DESCRIPTION
000 A2, A1, A0 DACL Attenuation	[7:0]	LAT[7:0]	11111111 (0dB)	Attenuation data for left channel in 0.5dB steps.
	8	UPDATEL	0	Attenuation data load control for left channel. 0: Store DACL in intermediate latch (no change to output) 1: Store DACL and update attenuation on all channels.
001 DACR Attenuation	[7:0]	RAT[7:0]	11111111 (0dB)	Attenuation data for right channel in 0.5dB steps.
	8	UPDATER	0	Attenuation data load control for right channel. 0: Store DACR in intermediate latch (no change to output) 1: Store DACR and update attenuation on all channels.
010 DAC Control	0	MUT	0	Left and right DACs soft mute control. 0: No mute 1: Mute
	1	DEEMPH	0	De-emphasis control. 0: De-emphasis off 1: De-emphasis on
	2	PWDN	0	Left and Right DACs Power-down Control 0: All DACs running, output is active 1: All DACs in power saving mode, output muted
	[5:3]	IW[2:0]	000	Audio data format select.
011 Interface Control	0	I ² S	0	Audio data format select.
	1	LRP	0	Polarity select for LRCIN/DSP mode select. 0: normal LRCIN polarity/DSP late mode 1: inverted LRCIN polarity/DSP early mode
	2	ATC	0	Attenuator Control. 0: All DACs use attenuations as programmed. 1: Right channel DACs use corresponding left DAC attenuations
	4	REV	0	Output phase reverse.
	5	BCP	0	BCKIN Polarity 0 : normal BCKIN polarity 1: inverted BCKIN polarity
	[7:6]	SF[1:0]	00	De-Emphasis sample rate select.
	8	IZD	0	Infinite zero detection circuit control and automute control 0: Infinite zero detect disabled 1: Infinite zero detect enabled

Table 8 Register Bit Descriptions

ATTENUATION CONTROL

Each DAC channel can be attenuated digitally before being applied to the digital filter. Attenuation is 0dB by default but can be set between 0 and 127.5dB in 0.5dB steps using the 8 Attenuation control bits. All attenuation registers are double latched allowing new values to be pre-latched to both channels before being updated synchronously. Setting the UPDATE bit on any attenuation write will cause all pre-latched values to be immediately applied to the DAC channels.

REGISTER ADDRESS A2, A1, A0	BIT	LABEL	DEFAULT	DESCRIPTION
000 DACL Attenuation	7:0	LAT[7:0]	11111111 (0dB)	Attenuation data for Left channel DACL in 0.5dB steps.
	8	UPDATEL	0	Controls simultaneous update of all Attenuation Latches 0: Store DACL in intermediate latch (no change to output) 1: Store DACL and update attenuation on all channels.
001 DACR Attenuation	7:0	RAT[7:0]	11111111 (0dB)	Attenuation data for Right channel DACR in 0.5dB steps.
	8	UPDATER	0	Controls simultaneous update of all Attenuation Latches 0: Store DACR in intermediate latch (no change to output) 1: Store DACR and update attenuation on all channels.

Table 9 Attenuation Register Map

Note:

- The UPDATE bit is not latched. If UPDATE=0, the Attenuation value will be written to the pre-latch but not applied to the relevant DAC. If UPDATE=1, all pre-latched values will be applied from the next input sample.
- Care should be used in reducing the attenuation as rapid large volume changes can introduce zipper noise.

DAC OUTPUT ATTENUATION

Registers LAT and RAT control the left and right channel attenuation. Table 10 shows how the attenuation levels are selected from the 8-bit words.

XAT[7:0]	ATTENUATION LEVEL
00(hex)	∞ dB (mute)
01(hex)	127.5dB
:	:
:	:
:	:
FE(hex)	0.5dB
FF(hex)	0dB

Table 10 Attenuation Control Levels

MUTE MODES

Setting the MUT register bit will apply a 'soft' mute to the input of the digital filters:

REGISTER ADDRESS	BIT	LABEL	DEFAULT	DESCRIPTION
010 DAC Control	0	MUT	0	Soft Mute select 0 : Normal Operation 1: Soft mute all channels

Table 11 Mute Control

DE-EMPHASIS MODE

Setting the DEEMPH register bit puts the all the digital filters into de-emphasis mode:

REGISTER ADDRESS	BIT	LABEL	DEFAULT	DESCRIPTION
010 DAC Control	1	DEEMPH	0	De-emphasis mode select: 0 : De-emphasis Off 1: De-emphasis On

Table 12 De-emphasis Control

POWERDOWN MODE

Setting the PWDN register bit immediately connects all outputs to V_{MID} and selects a low power mode. All trace of the previous input samples is removed, and all register settings are cleared. When PWDN is cleared again the first 16 input samples will be ignored as the FIR will repeat it's power-on initialisation sequence.

REGISTER ADDRESS	BIT	LABEL	DEFAULT	DESCRIPTION
010 DAC Control	2	PWDN	0	Power Down Mode Select: 0 : Normal Mode 1: Power Down Mode

Table 13 Powerdown Control

DIGITAL AUDIO INTERFACE CONTROL REGISTERS

The WM8706 has a fully featured digital audio interface that is a superset of that contained in the WM8716. Interface format is selected via the IW[2:0] register bits in register M2 and the I²S register bit in M3.

REGISTER ADDRESS	BIT	LABEL	DEFAULT	DESCRIPTION
010 DAC Control	5:3	IW[2:0]	000	Interface format Select

Table 14 Interface Format Controls

REGISTER ADDRESS	BIT	LABEL	DEFAULT	DESCRIPTION
011 Interface Control	0	I ² S	0	Interface format Select

Table 15 Interface Format Control

IW2	I ² S	IW1	IW0	AUDIO INTERFACE DESCRIPTION **
0	0	0	0	16 bit right justified mode
0	0	0	1	20 bit right justified mode
0	0	1	0	24 bit right justified mode
0	0	1	1	24 bit left justified mode
0	1	0	0	16 bit I ² S mode
0	1	0	1	24 bit I ² S mode
0	1	1	0	20 bit I ² S mode
0	1	1	1	20 bit left justified (MSB first) mode
1	0	0	0	16 bit DSP mode
1	0	0	1	20 bit DSP mode
1	0	1	0	24 bit DSP mode
1	0	1	1	32 bit DSP mode
1	1	0	0	16 bit left justified mode

Table 16 Audio Data Input Format

Note:

** In all modes, the data is signed 2's complement. The digital filters always input 24-bit data. If the DAC is programmed to receive 16 or 20 bit data, the WM8706 pads the unused LSBs with zeros. If the DAC is programmed into 32 bit mode, the 4 LSBs are ignored.

SELECTION OF LRCIN POLARITY

In left justified, right justified or I²S modes, the LRP register bit controls the polarity of LRCIN. If this bit is set high, the expected polarity of LRCIN will be the opposite of that shown in Figure 4, Figure 5 and Figure 6. Note that if this feature is used as a means of swapping the left and right channels, a 1 sample phase difference will be introduced.

REGISTER ADDRESS	BIT	LABEL	DEFAULT	DESCRIPTION
011 Interface Control	1	LRP	0	LRCIN Polarity (normal) 0 : normal LRCIN polarity 1: inverted LRCIN polarity

Table 17 LRCIN Polarity Control

In DSP modes, the LRCIN register bit is used to select between early and late modes:

REGISTER ADDRESS	BIT	LABEL	DEFAULT	DESCRIPTION
011 Interface Control	1	LRP	0	DSP Format (DSP modes) 0 : Early DSP mode 1: Late DSP mode

Table 18 DSP Format Control

In DSP early mode, the first bit is sampled on the BCKIN rising edge following the one that detects a low to high transition on LRCIN. In DSP late mode, the first bit is sampled on the BCKIN edge, which detects a low to high transition on LRCIN. No BCKIN rising edges are allowed between the data words. The word order is DIN left, DIN right.

ATTENUATOR CONTROL MODE

Setting the ATC register bit causes the left channel attenuation settings to be applied to both left and right channel DACs from the next audio input sample. No update to the attenuation registers is required for ATC to take effect.

REGISTER ADDRESS	BIT	LABEL	DEFAULT	DESCRIPTION
011 Interface Control	2	ATC	0	Attenuate Control Mode: 0 : Right channels use Right attenuation 1: Right Channels use Left Attenuation

Table 19 Attenuation Control Select

OUTPUT PHASE REVERSAL

The REV register bit controls the phase of the output signal. Setting the REV bit causes the phase of the output signal to be inverted.

REGISTER ADDRESS	BIT	LABEL	DEFAULT	DESCRIPTION
011 Interface Control	4	REV	0	Analogue Output Phase 0: Normal 1: Inverted

Table 20 Output Phase Control

BCKIN POLARITY

By default, LRCIN and DIN are sampled on the rising edge of BCKIN and should ideally change on the falling edge. Data sources which change LRCIN and DIN on the rising edge of BCKIN can be supported by setting the BCP register bit. Setting BCP to 1 inverts the polarity of BCKIN to the inverse of that shown in Figure 4, Figure 5, Figure 6, Figure 7 and Figure 8.

REGISTER ADDRESS	BIT	LABEL	DEFAULT	DESCRIPTION
011 Interface Control	5	BCP	0	BCKIN Polarity 0 : normal BCKIN polarity 1: inverted BCKIN polarity

Table 21 BCKIN Polarity Control

DE-EMPHASIS SAMPLE RATE SELECTION

The SF[1:0] bits are used to select the de-emphasis rate.

REGISTER ADDRESS	BIT	LABEL	DEFAULT	DESCRIPTION **
0011 Interface Control	7:6	SF[1:0]	00	De-Emphasis Sample Rate Selection 00 : De-Emphasis Off 01: 48kHz 10: 44.1kHz 11: 32kHz

Table 22 De-emphasis Control

Note:

** There is only one internal de-emphasis mode optimised for 44.1kHz. This is in contrast to WM8716 which is individually optimised for each sample rate.

INFINITE ZERO DETECTION

Setting the IZD register bit determines whether the device is automuted when a sequence of more than 1024 zeros is detected.

REGISTER ADDRESS	BIT	LABEL	DEFAULT	DESCRIPTION
011 Interface Control	8	IZD	0	Infinite zero detection circuit control and automute control 0: Infinite zero detect disabled 1: Infinite zero detect enabled

Table 23 IZD Control

DIGITAL FILTER CHARACTERISTICS

PARAMETER	SYMBOL	TEST CONDITIONS	MIN	TYP	MAX	UNIT
Passband Edge		-3dB		0.487fs		
Passband Ripple		$f < 0.444fs$			± 0.05	dB
Stopband Attenuation		$f > 0.555fs$	-60			dB

Table 24 Digital Filter Characteristics

DAC FILTER RESPONSES

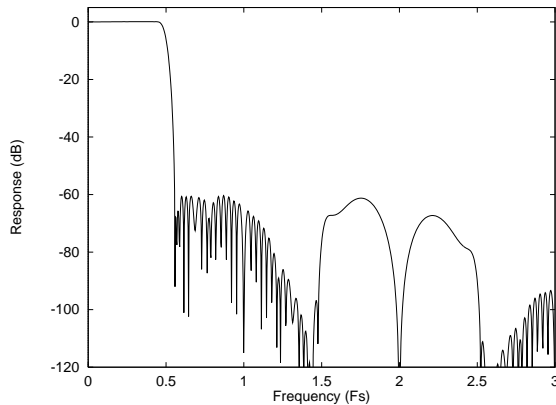

Figure 12 DAC Digital Filter Frequency Response - 44.1, 48 and 96kHz

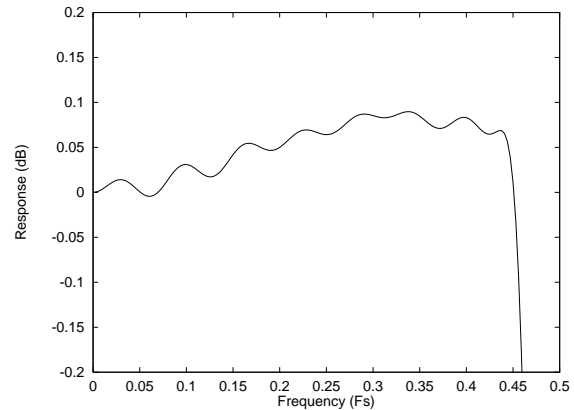

Figure 13 DAC Digital Filter Ripple - 44.1, 48 and 96kHz

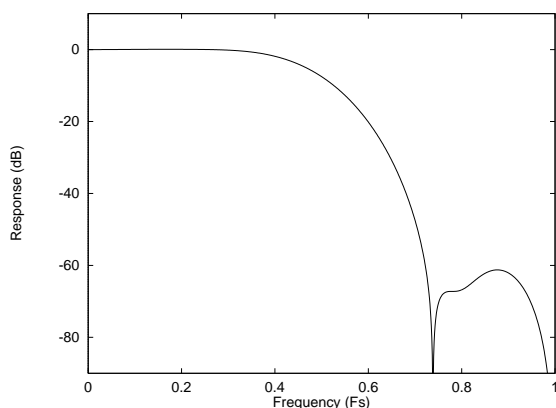

Figure 14 DAC Digital Filter Frequency Response - 192kHz

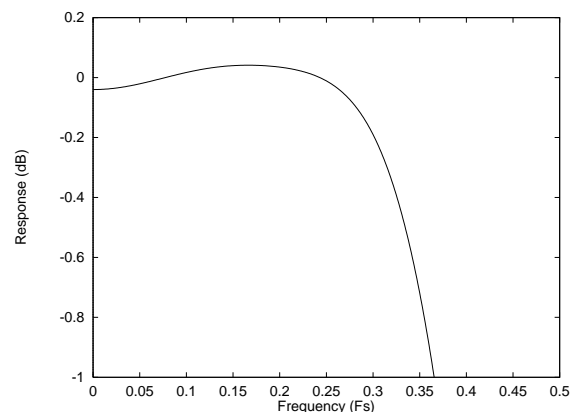

Figure 15 DAC Digital Filter Ripple - 192kHz

DIGITAL DE-EMPHASIS CHARACTERISTICS

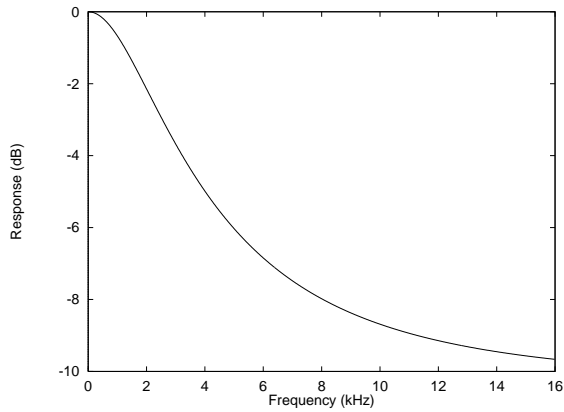

Figure 16 De-Emphasis Frequency Response (32kHz)

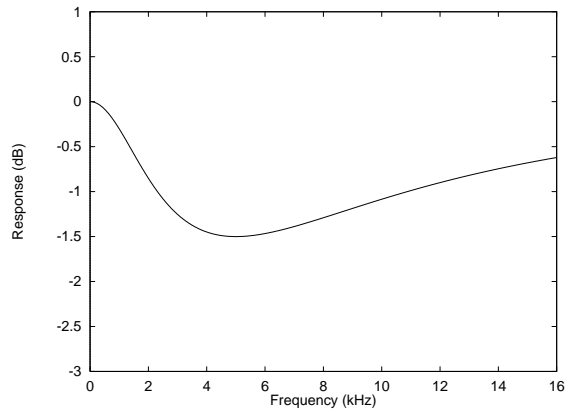

Figure 17 De-Emphasis Error (32kHz)

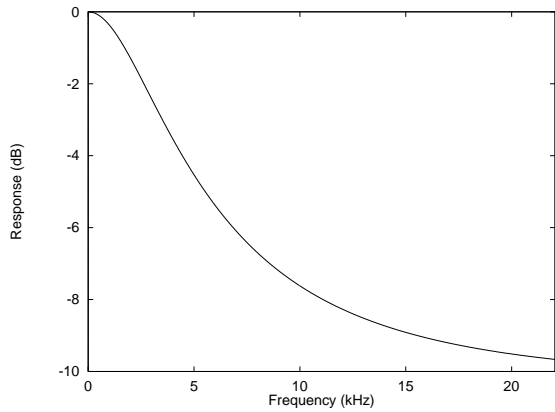

Figure 18 De-Emphasis Frequency Response (44.1kHz)

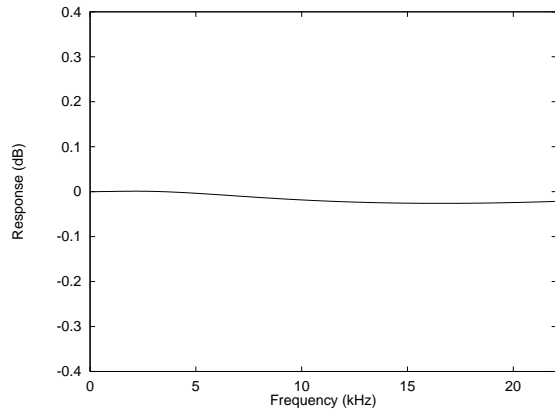

Figure 19 De-Emphasis Error (44.1kHz)

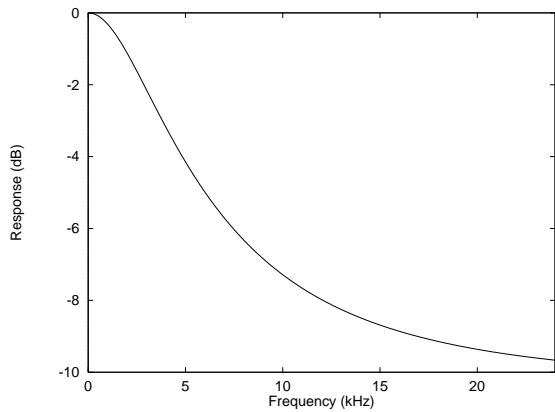

Figure 20 De-Emphasis Frequency Response (48kHz)

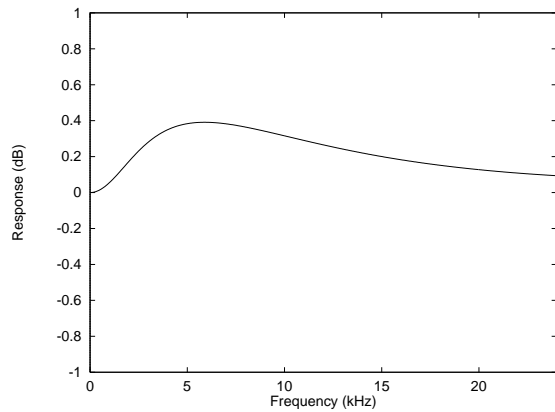

Figure 21 De-Emphasis Error (48kHz)

RECOMMENDED EXTERNAL COMPONENTS

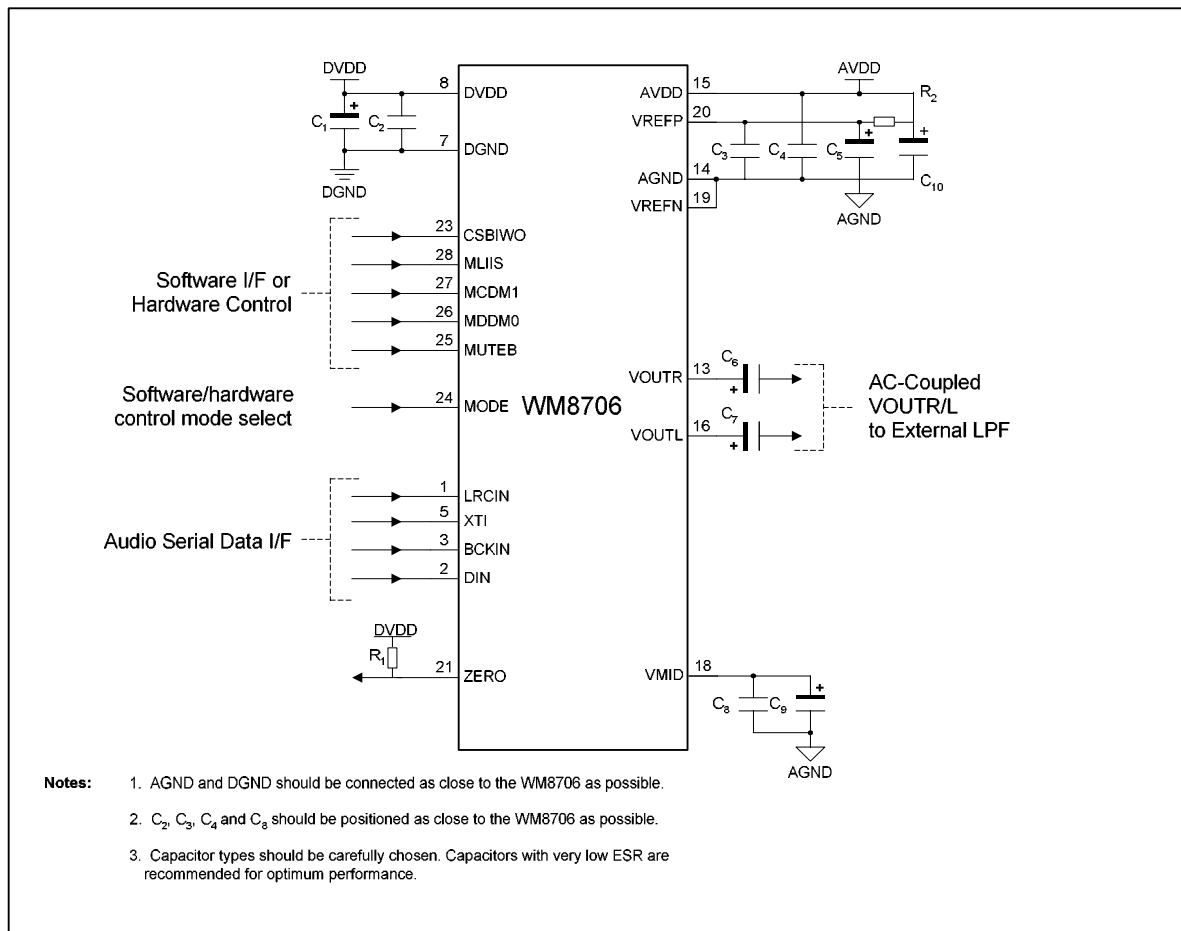

Figure 22 External Components Diagram

RECOMMENDED EXTERNAL COMPONENT VALUES

COMPONENT REFERENCE	SUGGESTED VALUE	DESCRIPTION
C1 and C5	10µF	De-coupling for DVDD and AVDD/VREFP
C2 to C4	0.1µF	De-coupling for DVDD and AVDD/VREFP
C6 and C7	10µF	Output AC coupling caps to remove midrail DC level from outputs.
C8	0.1µF	Reference de-coupling capacitors for VMID pin.
C9	10µF	
C10	10µF	Filtering for VREFP. Omit if AVDD low noise.
R1	10kΩ	10k pull-up to DVDD.
R2	33Ω	Filtering for VREFP. Use 0Ω if AVDD low noise.

Table 25 External Components Description

RECOMMENDED ANALOGUE LOW PASS FILTER (OPTIONAL)

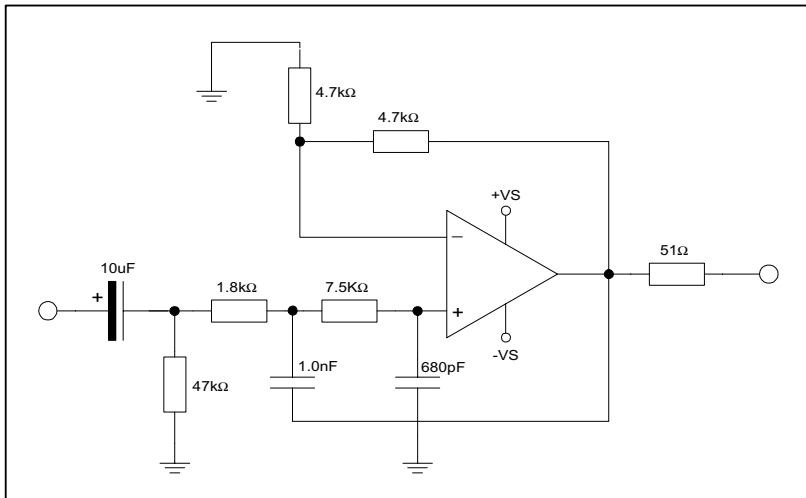
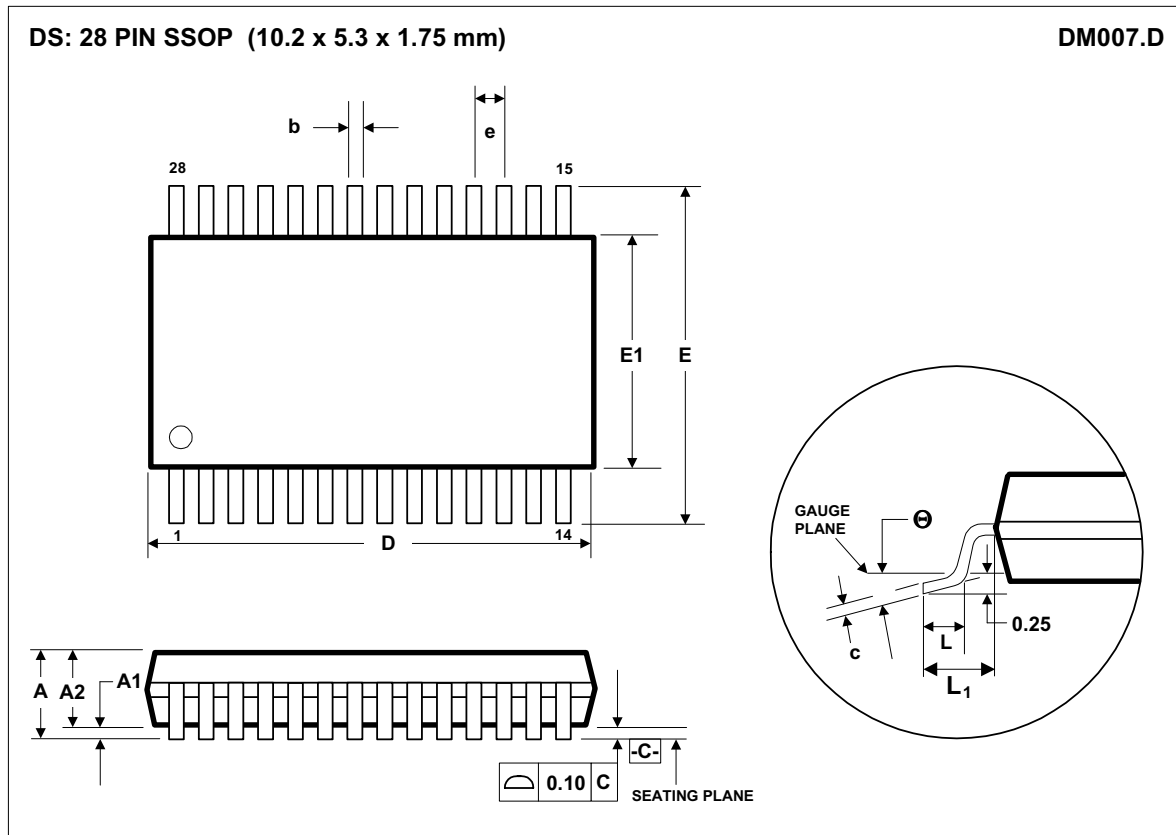

Figure 23 Recommended Low Pass Filter (Optional)

PACKAGE DIMENSIONS



Symbols	Dimensions (mm)		
	MIN	NOM	MAX
A	-----	-----	2.0
A₁	0.05	-----	0.25
A₂	1.65	1.75	1.85
b	0.22	0.30	0.38
c	0.09	-----	0.25
D	9.90	10.20	10.50
e	0.65 BSC		
E	7.40	7.80	8.20
E₁	5.00	5.30	5.60
L	0.55	0.75	0.95
L₁	0.125 REF		
θ	0°	4°	8°
REF:	JEDEC.95, MO-150		

- NOTES:
- A. ALL LINEAR DIMENSIONS ARE IN MILLIMETERS.
 - B. THIS DRAWING IS SUBJECT TO CHANGE WITHOUT NOTICE.
 - C. BODY DIMENSIONS DO NOT INCLUDE MOLD FLASH OR PROTRUSION, NOT TO EXCEED 0.20MM.
 - D. MEETS JEDEC.95 MO-150, VARIATION = AH. REFER TO THIS SPECIFICATION FOR FURTHER DETAILS.

IMPORTANT NOTICE

Wolfson Microelectronics plc (WM) reserve the right to make changes to their products or to discontinue any product or service without notice, and advise customers to obtain the latest version of relevant information to verify, before placing orders, that information being relied on is current. All products are sold subject to the WM terms and conditions of sale supplied at the time of order acknowledgement, including those pertaining to warranty, patent infringement, and limitation of liability.

WM warrants performance of its products to the specifications applicable at the time of sale in accordance with WM's standard warranty. Testing and other quality control techniques are utilised to the extent WM deems necessary to support this warranty. Specific testing of all parameters of each device is not necessarily performed, except those mandated by government requirements.

In order to minimise risks associated with customer applications, adequate design and operating safeguards must be used by the customer to minimise inherent or procedural hazards. Wolfson products are not authorised for use as critical components in life support devices or systems without the express written approval of an officer of the company. Life support devices or systems are devices or systems that are intended for surgical implant into the body, or support or sustain life, and whose failure to perform when properly used in accordance with instructions for use provided, can be reasonably expected to result in a significant injury to the user. A critical component is any component of a life support device or system whose failure to perform can be reasonably expected to cause the failure of the life support device or system, or to affect its safety or effectiveness.

WM assumes no liability for applications assistance or customer product design. WM does not warrant or represent that any license, either express or implied, is granted under any patent right, copyright, mask work right, or other intellectual property right of WM covering or relating to any combination, machine, or process in which such products or services might be or are used. WM's publication of information regarding any third party's products or services does not constitute WM's approval, license, warranty or endorsement thereof.

Reproduction of information from the WM web site or datasheets is permissible only if reproduction is without alteration and is accompanied by all associated warranties, conditions, limitations and notices. Representation or reproduction of this information with alteration voids all warranties provided for an associated WM product or service, is an unfair and deceptive business practice, and WM is not responsible nor liable for any such use.

Resale of WM's products or services with statements different from or beyond the parameters stated by WM for that product or service voids all express and any implied warranties for the associated WM product or service, is an unfair and deceptive business practice, and WM is not responsible nor liable for any such use.

ADDRESS:

Wolfson Microelectronics plc
26 Westfield Road
Edinburgh
EH11 2QB
United Kingdom

Tel :: +44 (0)131 272 7000

Fax :: +44 (0)131 272 7001

Email :: sales@wolfsonmicro.com