

FOUNDATION GA3216

Digital Single or Dual Channel DSP Compression System

Description

The FOUNDATION® GA3216 hybrid is a trimmer-configurable DSP system based on a two-channel compression circuit. It can efficiently replace traditional hearing-aid compression circuits without compromising fundamental performance requirements.

A trimmer interface supports manual circuit configuration. It continuously monitors trimmer positions and translates them into the hearing-aid parameters of choice. A serial data interface provides full programmability at the factory and in the field.

The Foundation GA3216 includes in-channel squelch to attenuate microphone and circuit noise in quiet environments. It also includes low-distortion compression limiting and programmable high and low cut filters, as well as five configurable equalization filters. Unused blocks can be powered down to save battery current, for example, when using the device in single-channel mode.

The Foundation GA3216 Hybrid code programmed into the GC5020 controller chip is '1'.

This data sheet is part of a documentation set available for this product. For a list of other documents, refer to Getting Started with Foundation Digital.

Features

- Efficient, High Fidelity 1 or 2-Channel WDRC Signal Processing
- Fully Programmable via Serial Data Interface
- High-Fidelity Audio Quality
- Four Trimmer Inputs plus Volume Control
- Flexible Trimmer/Parameter Assignments
- Optional Two-Terminal or Three-Terminal Trimmers
- Choice of Wideband or Independent 2-Channel Level Detection
- Choice of Two Strategies for AGC-I Parametric Adjustment
- 6, 12 or 24 dB/Octave Band Split Filter or Configurable as Single-Channel Compressor
- In-Channel, Low Level Squelch Control (1:2 Expansion)
- Output Compression Limiting (AGC-O)
- Flexible Pre- and Post-Emphasis Filters
- Four Independent Memories
- Pulse-Density-Modulated Output Stage Drives Zero-Bias 2-Terminal Receivers
- High-Power Drive Capability
- Unused Blocks can be Powered Down
- thinSTAX® Packaging
- Also Available as E1 (RoHS Compliant Hybrid)



ON Semiconductor®

<http://onsemi.com>

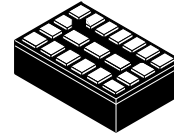

20 PAD
HYBRID
CASE TBD

PAD CONNECTION

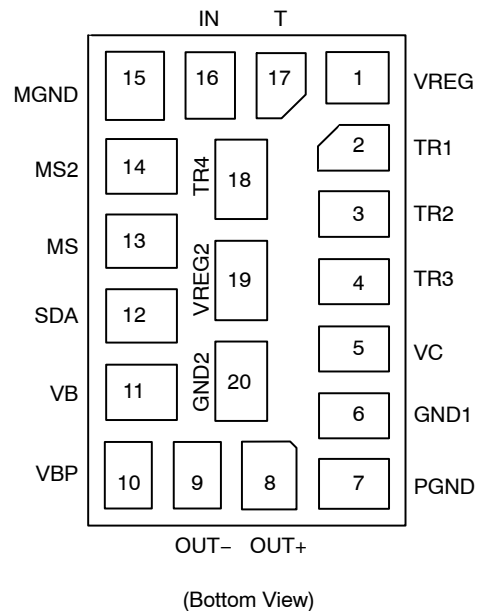

MARKING DIAGRAM

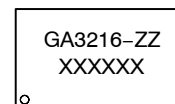

GA3216 = Specific Device Code
 ZZ = E1: RoHS Compliant Hybrid
 Missing ZZ = Non-RoHS Compliant
 XXXXXX = Work Order Number

ORDERING INFORMATION

Device	Shipping
GA3216-E1-B	25 Units / Bubble Pack
GA3216-E1-T	500 Units / Tape & Reel

FOUNDATION GA3216

thinSTAX Packaging

- Hybrid Typical Dimensions:
0.190 x 0.123 x 0.060 in.
(4.82 x 3.12 x 1.52 mm)

BLOCK DIAGRAM

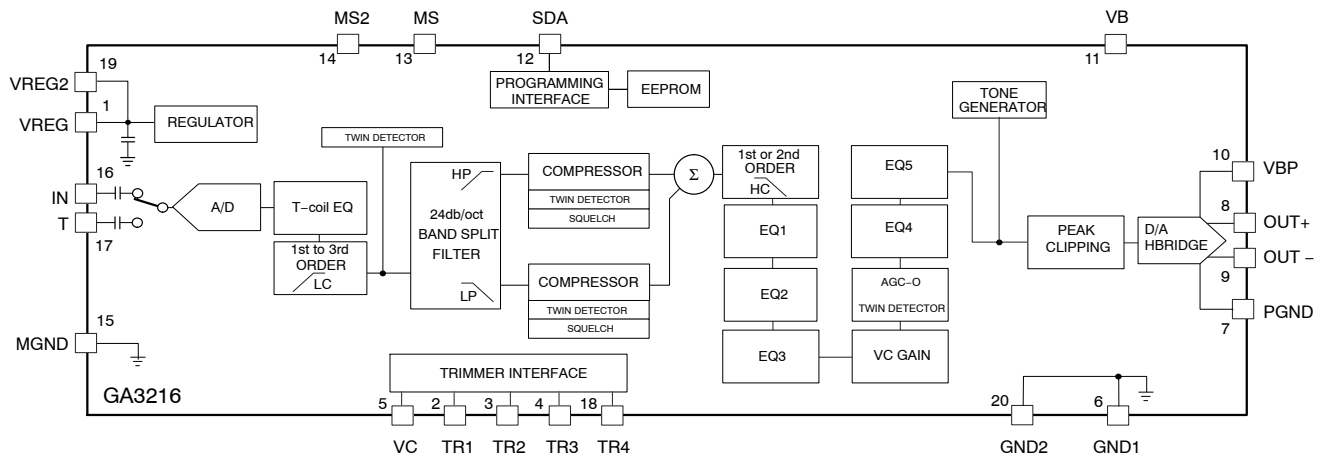

Figure 1. Foundation GA3216 Block Diagram

Table 1. ABSOLUTE MAXIMUM RATINGS

Parameter	Value	Units
Operating Temperature Range	-10 to +40	°C
Storage Temperature Range	-20 to +70	°C
Absolute Maximum Power Dissipation	25	mW
Input ESD Voltage	2000	V
Maximum Operating Supply Voltage	1.5	VDC
Absolute Maximum Supply Voltage	2	VDC

Stresses exceeding Maximum Ratings may damage the device. Maximum Ratings are stress ratings only. Functional operation above the Recommended Operating Conditions is not implied. Extended exposure to stresses above the Recommended Operating Conditions may affect device reliability.

WARNING: Electrostatic Sensitive Device – Do not open packages or handle except at a static-free workstation.

WARNING: Moisture Sensitive Device – Non-RoHS Compliant – Level 3 MSL; RoHS Compliant – Level 4 MSL. Do not open packages except under controlled conditions.

FOUNDATION GA3216

Table 2. ELECTRICAL CHARACTERISTICS – PART 1

(Conditions: Supply Voltage $V_B = 1.3$ V; Temperature = 25°C, 16 kHz bandwidth)

Parameter	Symbol	Conditions	Min	Typ	Max	Units
Hybrid Current	I_{AMP}	All functions, 24 kHz sampling rate	–	540	–	μ A
		All functions, 32 kHz sampling rate	–	650	–	
Minimum Operating Supply Voltage	V_{BOFF}	Ramp down	0.95	–	0.980	V
Supply Voltage Turn On Threshold	V_{BON}	Ramp up	1.065	1.10	1.160	V
Supply Voltage Hysteresis	–	$V_{BON} - V_{BOFF}$	–	150	–	mV
Low Battery Warning Voltage	–	Ramp down	1.06	1.10	1.14	V
Supply Voltage During Communication	V_{BC}	During Communication	1.20	1.30	–	V
EEPROM Burn Cycles	–	(Note 2)	100 k	–	–	cycles
Low Frequency System Bandwidth	–	–	–	130	–	Hz
High Frequency System Bandwidth	–	32 kHz sampling frequency	–	16	–	kHz
		24 kHz sampling frequency	–	12	–	
Total Maximum System Gain	A_V	$V_{IN} = -95$ dBV at 3 kHz; squelch disabled (Note 1)	82	83	84	dB
Converter Gain	A_{CONV}	A/D + D/A gain	28	29	30	dB
Total Harmonic Distortion	THD	$V_{IN} = -40$ dBV	–	–	1	%
THD at Maximum Input	THD _M	$V_{IN} = -14$ dBV, HRX – ON	–	–	3	%
Clock Frequency	f_{clk}	–	1.963	2.048	2.115	MHz

REGULATOR

Regulator Voltage	V_{REG}	–	0.87	0.90	0.93	V
Regulator Supply Rejection	PSRR _{REG}	–	–	36	–	dB

VOLUME CONTROL AND TRIMMERS

Volume Control or Trimmer Resistance	R_{VC}	Two-terminal Trimmer (Note 3)	–	200	–	k Ω
		Three-terminal Trimmer (Note 3)	0.1	–	1	M Ω
Volume Control Range	ΔA	–	–	48	–	dB

MS AND MS2 INPUT

Pull Down / Up Resistance	–	–	–	1	–	M Ω
Logic 1 Voltage	–	–	–	V_{REG}	–	V
Logic 0 Voltage	–	–	–	0	–	V

INPUT

Input Referred Noise	IRN	Bandwidth 100 Hz – 8 kHz	–	–109	–108	dBV
Input Impedance	Z_{IN}	–	13.5	16	18.5	k Ω
Crosstalk	–	Between microphone and telecoil inputs	–	–60	–	dB
Maximum Input Level	–	–	–	–14	–	dBV
Input Dynamic Range	–	HRX – ON, Bandwidth 100 Hz – 8 kHz	–	95	–	dB

OUTPUT

Maximum RMS Output Voltage	–	0 dBFS $f = 1$ kHz	–	–1	–	dBV
D/A Dynamic Range	–	Bandwidth 100 Hz – 8 kHz	–	83	–	dB
Output Impedance	Z_{OUT}	–	–	10	20	Ω

- Total System Gain consists of: Wideband System Gain + High and Low Independent Channel Gains + Converter Gain.
Total System Gain is calibrated during Cal/Config process.
- Sample tested.
- Volume control is log taper, trimmers are linear taper.

FOUNDATION GA3216

Table 2. ELECTRICAL CHARACTERISTICS – PART 1

(Conditions: Supply Voltage $V_B = 1.3$ V; Temperature = 25°C, 16 kHz bandwidth)

Parameter	Symbol	Conditions	Min	Typ	Max	Units
SDA INPUT						
Logic 0 Voltage	–	(Note 2)	0	–	0.3	V
Logic 1 Voltage	–	(Note 2)	1	–	1.3	V
SDA OUTPUT						
Synchronization Time (Synchronization Pulse Width)	T_{SYNC}	Baud = 0	237	250	263	μ s
		Baud = 1	118	125	132	
		Baud = 2	59	62.5	66	

- Total System Gain consists of: Wideband System Gain + High and Low Independent Channel Gains + Converter Gain.
Total System Gain is calibrated during Cal/Config process.
- Sample tested.
- Volume control is log taper, trimmers are linear taper.

Table 3. ELECTRICAL CHARACTERISTICS – PART 2

Parameter	Min	Max	Units	Accuracy
TELECOIL				
Telecoil Gain	–8	23	dB	Type 3
Low Pass Compensation Filter	0.5	1	kHz	Type 1
FREQUENCY SHAPING				
Crossover Frequency	0.5	4.25	kHz	Type 1, 2
High Cut Filter	1	16	kHz	Type 1, 2
High Cut Filter Order	6 or 12	–	dB/Octave	N/A
Low Cut Filter	0.01	3	kHz	Type 1, 2
Low Cut Filter Order	6, 12 or 18	–	dB/Octave	–
Equalization Filter Center	0.125	16	kHz	Type 1, 2
Equalization Filter Depth	–30	30	dB	–
Equalization Filter Q	0.7079	70.7946	–	–
INDEPENDENT CHANNEL PROCESSING				
Bandsplit Filter Slopes	6, 12 or 24	–	dB/Octave	Type 1, 2
Low Level Gain	–18	42	dB	Type 3
High Level Gain	–18	42	dB	Type 3
Lower Threshold	30	110	dB SPL	Type 3
Upper Threshold	70	110	dB SPL	Type 3
Compression Ratio	1 : 1	∞ : 1	Ratio	Type 3
AGC Attack Time Constant (Fast & Slow)	0.25	8192	ms	Type 1, 3
AGC Release Time Constant (Fast & Slow)	0.25	8192	ms	Type 1, 3
Squelch Expansion Ratio	1 : 2	1 : 2	Ratio	N/A
Squelch Threshold	20	60	dB SPL	Type 3
Squelch Attack Time Constant	0.25	8192	ms	Type 1, 3
Squelch Release Time Constant	0.25	8192	ms	Type 1, 3
WIDEBAND SYSTEM GAIN				
Wideband System Gain	–36	12	dB	Type 3
Wideband Attack Time Constant (Fast & Slow)	0.25	8192	ms	Type 1, 3

FOUNDATION GA3216

Table 3. ELECTRICAL CHARACTERISTICS – PART 2

Parameter	Min	Max	Units	Accuracy
WIDEBAND SYSTEM GAIN				
Wideband Release Time Constant (Fast & Slow)	0.25	8192	ms	Type 1, 3
External VC	-48	0	dB	Type 3
Internal VC Attenuator	-48	0	dB	Type 3
TOTAL SYSTEM GAIN				
Total System Gain	-19	83	dB	(Note 1)
AGC-O				
AGC-O Output Limiting	-30	-1	dBFS*	Type 3
AGC-O Compression Ratio	$\infty : 1$	$\infty : 1$	Ratio	N/A
AGC-O Attack Time Constant (Fast & Slow)	0.25	8192	ms	Type 1, 3
AGC-O Release Time Constant (Fast & Slow)	0.25	8192	ms	Type 1, 3
PEAK CLIPPER				
PC Output Limiting	-40	0	dBFS	Type 3
TONE GENERATOR				
Pure Tone Frequency (memory and low battery indicator)	0.25	16	kHz	Type 1, 2
Pure Tone Amplitude (memory and low battery indicator)	-50	0	dBFS	Type 3

1. Total System Gain consists of: Wideband System Gain + High and Low Independent Channel Gains + Converter Gain and accuracy of this parameter is dependent on accuracy of the components.

*Peak output is defined as largest sine wave possible at the resonant frequency of the receiver.

Accuracy definitions:

Type 1: accuracy is determined by the clock frequency deviation

Type 2: accuracy is determined by the quantization error of 16 bit coefficient and 20 bit or higher data word

Type 3: accuracy is determined by the quantization error of a parameter word (see table 2 for word length) and 20 bit or higher data word

TYPICAL APPLICATIONS

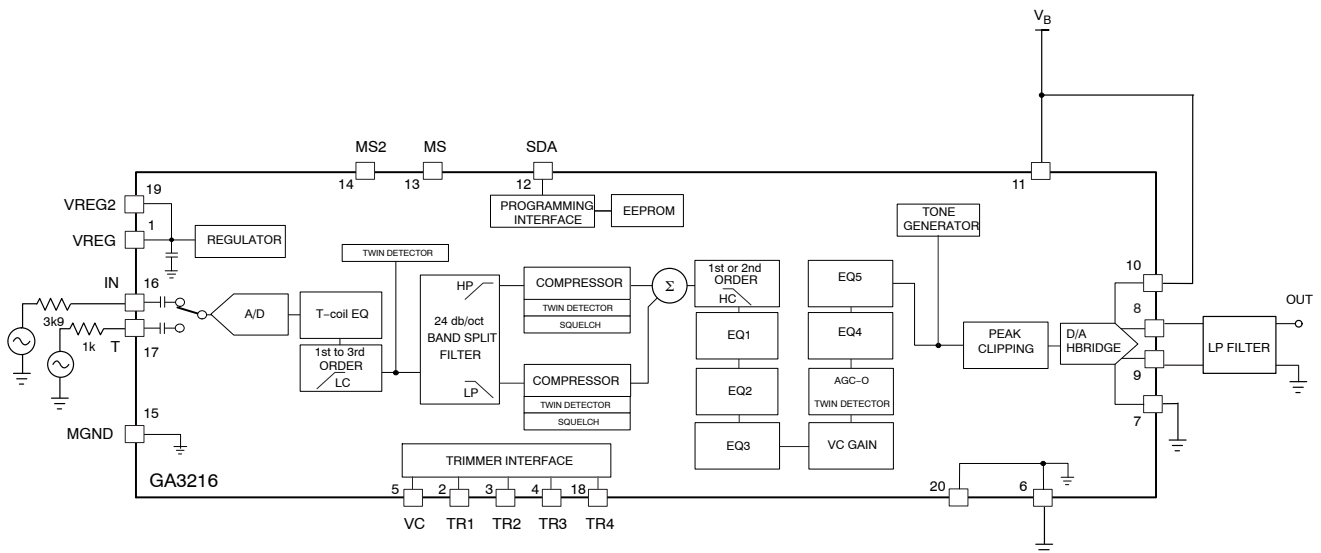

Note: All resistors in ohms and all capacitors in farads, unless otherwise stated.

Figure 2. Test Circuit

FOUNDATION GA3216

TYPICAL APPLICATIONS (Cont'd)

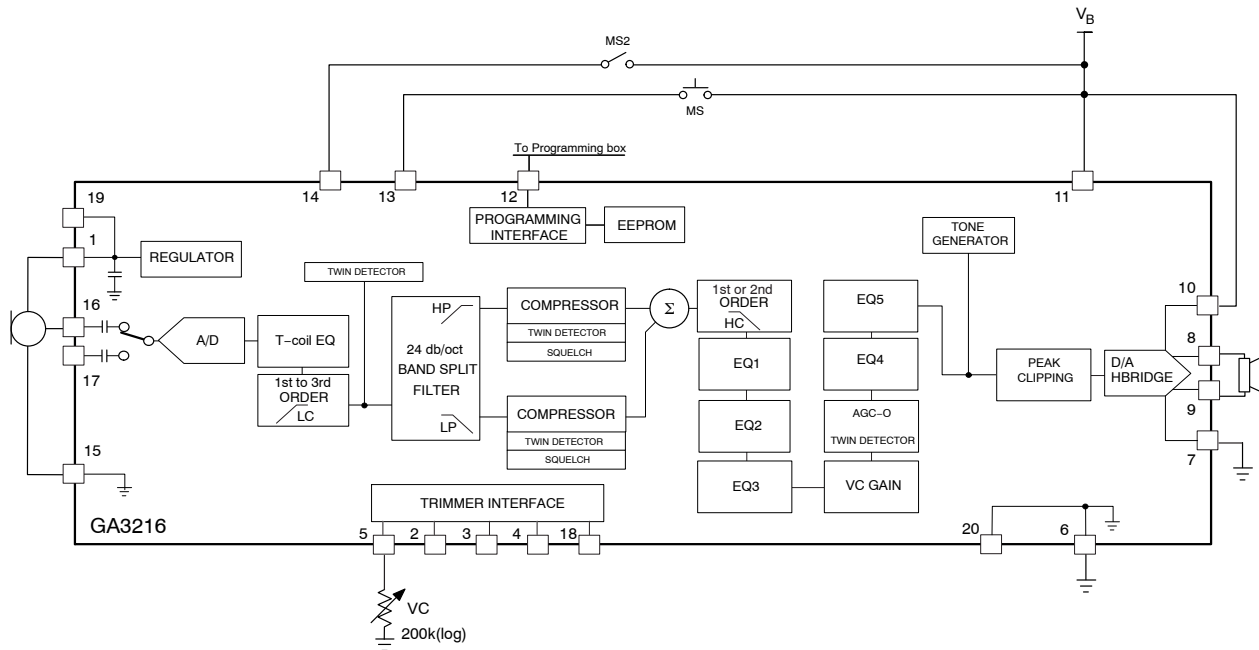

Note: All resistors in ohms and all capacitors in farads, unless otherwise stated.

Figure 3. Example of Programmable Application Circuit

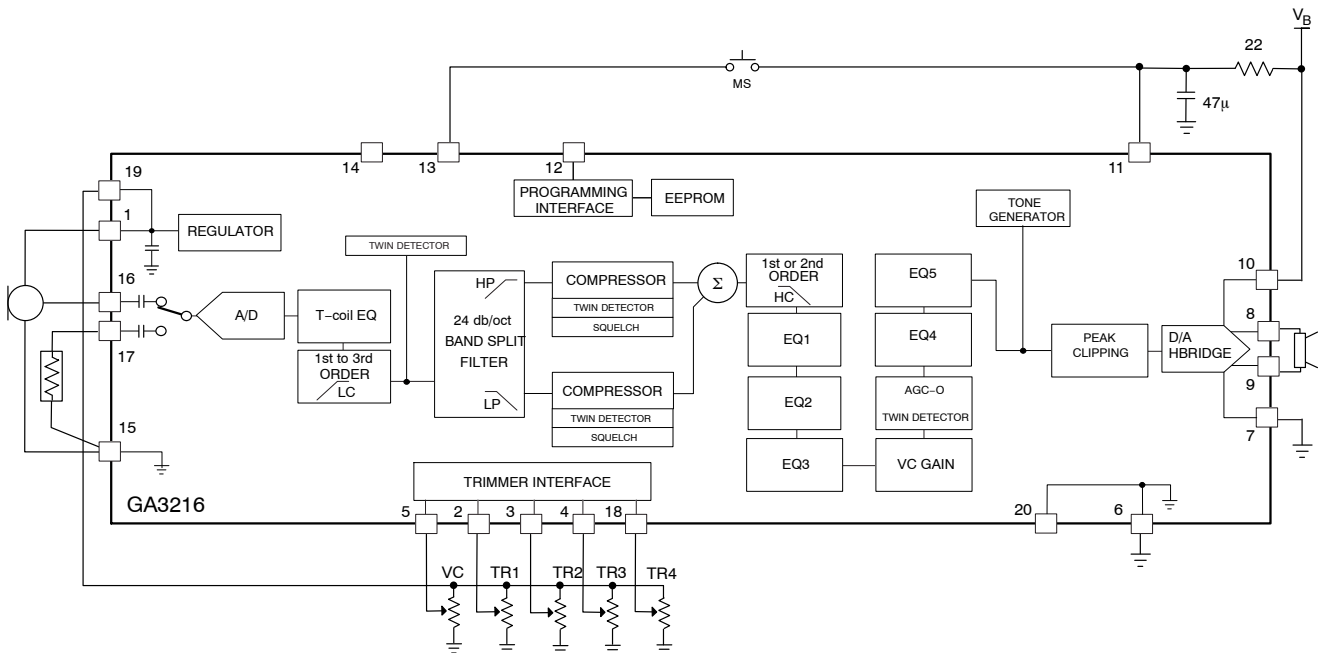

Note: All resistors in ohms and all capacitors in farads, unless otherwise stated.

Figure 4. Example of Trimmer Application Circuit

FOUNDATION GA3216

TYPICAL APPLICATIONS (Cont'd)

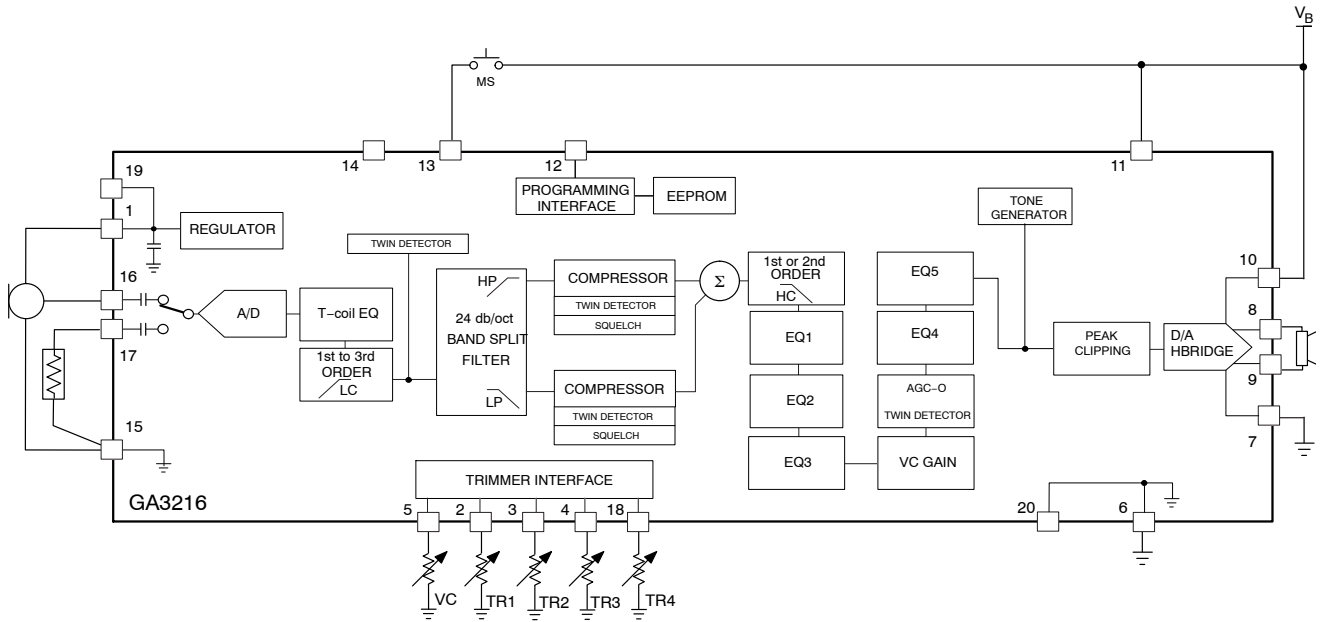

Note: All resistors in ohms and all capacitors in farads, unless otherwise stated.

Figure 5. Application Circuit for Figure 6

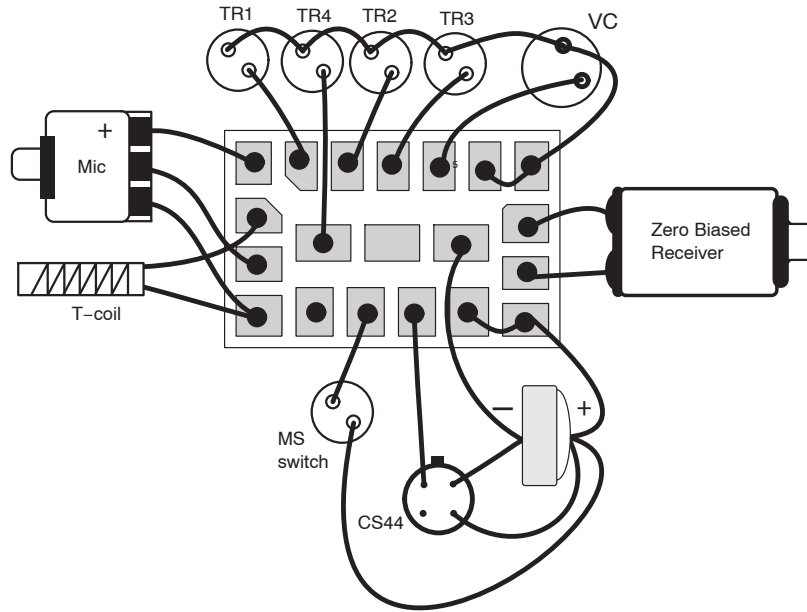

Figure 6. Example of Assembly Diagram for Two-Terminal Trimmer Circuit

FOUNDATION GA3216

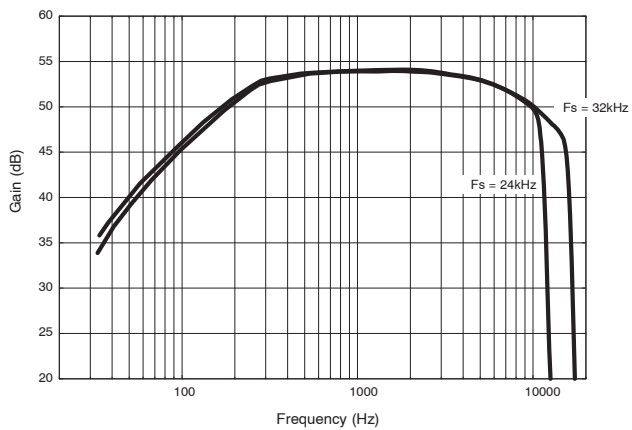

Figure 7. Frequency Response at 32 kHz and 24 kHz Sampling Frequency

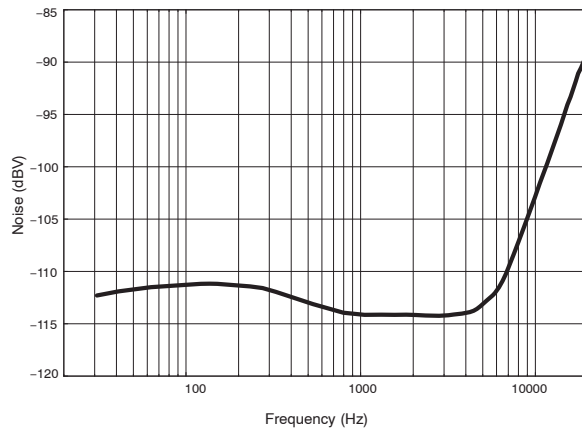

Figure 8. Output Noise

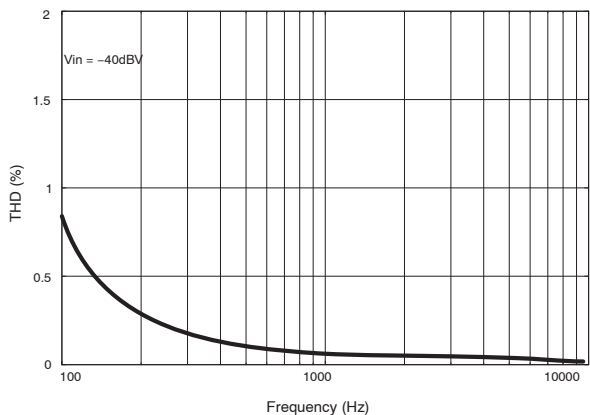

Figure 9. THD vs. Frequency

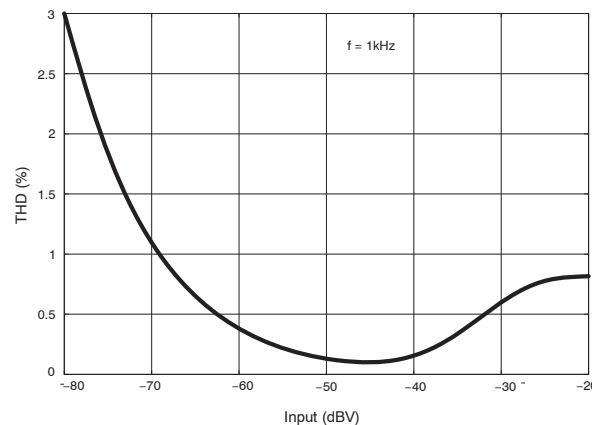

Figure 10. THD vs. Input Level

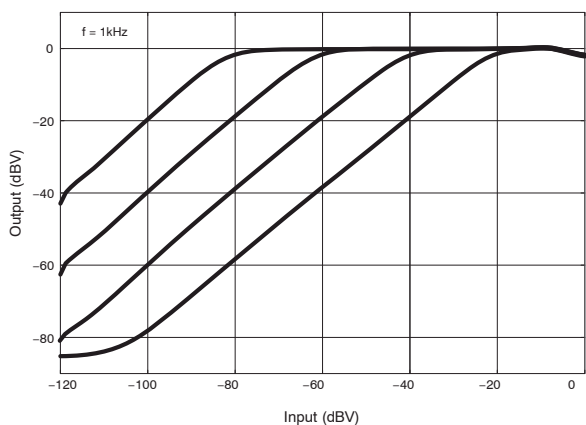

Figure 11. Input/Output Curves at Various Gains

FOUNDATION GA3216

FOUNDATION GA3216 OVERVIEW

The Foundation GA3216 hybrid comprises a configurable two-channel compressor circuit with two methods of operation programmable mode and trimmer mode. It may be configured as a one or two channel device with linear or WDRC processing. Configuration data stored in non-volatile memory defines hearing-aid parameters. This data needs to be uploaded to the hybrid before the circuit becomes functional. The Foundation GA3216 hybrid is programmed via the SDA pin using industry-standard programming boxes.

Configuration data is generated by an ARK product component library (DLL). Like the PARAGON® Digital products, the Foundation GA3216 is fully supported by

ON Semiconductor's software tools available from the ARKonline® website <http://ark.sounddes.com/>

During normal trimmer mode operation, a low-speed A/D circuit monitors the positions of up to four manual trimmers and a VC potentiometer. Trimmer position changes are immediately interpreted and translated into new circuit parameter values, which are then used to update the signal path.

ON Semiconductor's Library Manager in ARKonline tool enables pre-defining of trimmer assignments for all common functions such as low-cut, high-cut, notch and resonant-peak-shift filtering, AGC parameters, wideband gain, and maximum power output (MPO).

SIGNAL PATH

There are two main audio input signal paths. The first path contains the Microphone and second path contains the Telecoil input as selected by a programmable MUX. The microphone input is intended as the main audio input for single-microphone applications. The two audio inputs are buffered, sampled and converted into digital form using an A/D converter. The digital output is then converted into a 32 kHz 20-bit digital audio signal. It is possible to save current by reducing the sampling rate to 24 kHz, which reduces the system's bandwidth from 16 kHz to 12 kHz.

In Telecoil mode, gains are trimmed during the Cal/Config process to compensate for microphone/Telecoil mismatches. The Telecoil input may also be used as a second microphone input, in which case the Telecoil compensation would be disabled. This can be achieved via the ARKonline wizard.

The wideband detector circuit output is routed to a band-split filter that divides the signal into two frequency bands. There is an option to configure the hybrid as a single

channel device that shuts down and bypasses the band-split filter. The signal in each frequency band is processed by an independent AGC loop. The gain in any band is a function of the energy detected in that band or the overall detected wide-band energy. The two frequency bands are then summed back into a wide-band signal.

Further processing capabilities include a 1st to 3rd order low cut filter before the band-split filter. After the two channels are summed together, there is a 1st or 2nd order high cut filter, and three EQ filters, followed by volume control, low-distortion AGC-O, and two post-AGC-O EQ filters.

All AGC loops use a feed-forward topology to ensure system stability. Detectors in the AGCi path and AGC-O path are twin fast/slow detectors with independently adjustable attack and release time constants. The squelch detector residing in the AGCi path is implemented as a single fast/slow detector.

FUNCTIONAL BLOCK DESCRIPTION

A/D and D/A Converter

The system's A/D converter is a 2nd-order sigma-delta modulator operating at a 2.048 MHz sample rate. The system's input is pre-conditioned with anti-alias filtering and a programmable gain pre-amplifier. The analog output is oversampled and modulated to produce a 1-bit pulse density modulated (PDM) data stream. The digital PDM data is then decimated down to pulse-code modulated (PCM) digital words at the system's sampling rate of 32 kHz.

The D/A is comprised of a digital 3rd-order sigma-delta modulator and an H-bridge. The modulator accepts PCM audio data from the DSP path and converts it into a 32-times oversampled, 1-bit PDM data stream, which is then

supplied to the H-bridge. The H-bridge is a specialized CMOS output driver used to convert the 1-bit data stream into a low-impedance, differential output voltage waveform suitable for driving zero-biased hearing aid receivers.

Channel Processing

Figure 12 represents the I/O characteristic of independent AGC channel processing. The I/O curve can be divided into four main regions:

- Low input level expansion (squelch) region
- Low input level linear region
- Compression region
- High input level linear region (return to linear)

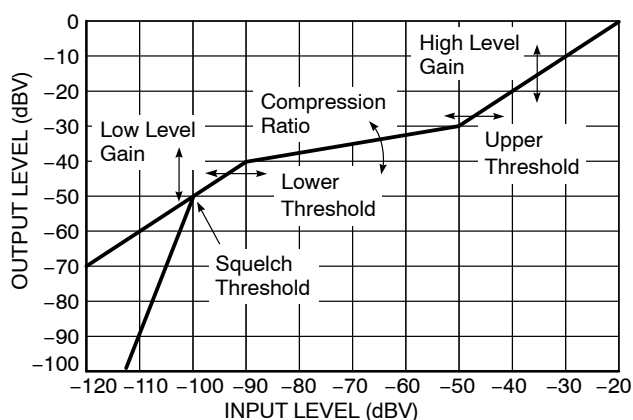

Figure 12. Independent Channel I/O Curve Flexibility

The I/O characteristic of the channel processing can be adjusted in the following ways:

- Squelch threshold (SQUELCHTH)
- Low level gain (LLGAIN)
- Lower threshold (LTH)
- High level gain (HLGAIN)
- Upper threshold (UTH)
- Compression ratio (CR)

During the Parameter Map creation, constraints are applied to the compression parameters to ensure that the I/O characteristics are continuous. In both Programmable mode and Trimmer mode, pre-defined parameter adjustments support two popular styles of compression ratio adjustment:

The compression region of the I/O curve pivots about the upper threshold. As the compression ratio trimmer is adjusted, high-level gain remains constant while the low-level gain changes.

The compression region of the I/O curve pivots about the lower threshold. Low-level gain remains constant as the compression ratio trimmer is adjusted.

The two compression channels can be controlled in tandem using a common wideband level detector, or independently using dedicated in-channel level detectors. Parameters such as low level gain, lower threshold and compression ratio can be combined and controlled by a single trimmer.

The squelch region within each channel implements a low level noise reduction scheme (1:2 expansion) for listener comfort. This scheme operates in quiet listening environments (programmable threshold) to reduce the gain at very low levels.

Single-channel compressor operation is supported by disabling the band split filter and one of the channel compressors. The remaining compressor can be configured as a wide-dynamic-range compressor (WDRC), or as an input compression limiter (ICL).

HRX™ Head Room Expander

The Foundation GA3216 contains an enhanced Head Room Expander (HRX) circuit, which increases the input

dynamic range of the Foundation GA3216 Digital without any unwanted audible artifacts. This is accomplished by dynamically adjusting the preamplifier's gain and the post-A/D attenuation depending on the input level.

Telecoil Path

The telecoil input is calibrated during the Cal/Config process. To compensate for the telecoil/microphone frequency response mismatch, a first order filter with 500 Hz corner frequency is implemented. Through ARKOnline, it is possible to implement a telecoil compensation filter with an adjustable corner frequency. To accommodate for the gain mismatch, the telecoil gain is adjusted to match the microphone gain at 500 Hz or 1 kHz (default) and is selectable in ARKOnline. There is also a telecoil gain adjustment parameter that can be enabled in ARKOnline and set in IDS, enabling manual adjustment of the telecoil gain compensation.

Volume Control & Trimmers

All parameters can be controlled via the SDA or assigned to the trimmers. The four trimmers have flexible parameter assignments so that any of them can be assigned to any available parameters. For a complete list of parameters, see ARK Online.

Both the external VC and trimmers can be configured to work with either a two-terminal 200 kΩ variable resistor or a three-terminal 0.1 MΩ – 1 MΩ variable resistor. The volume control should have a log taper, while the trimmers should have a linear taper.

In two-terminal configuration, the trimmers and VC are connected between GND and the trimmer Input and in three-terminal configuration between GND, Vreg and the trimmer Input. To enable the device to use two terminal trimmers, in IDS under Settings in the Cal/Config menu, on the trimmers tab select two terminal trimmers. If using two terminal trimmers, they must be calibrated before use. Calibration is not necessary with three terminal trimmer pots. Hysteresis is built into the circuitry to prevent unintentional level toggling.

Equalization Filters

There are five equalization filters provided on the Foundation GA3216 Digital for additional frequency shaping. Each EQ filter has three adjustable parameters, centre, depth and Q. One of these parameters can be selected as trimmer adjustable for each filter. For added flexibility, it is possible to combine EQ2 and EQ3, or EQ4 and EQ5, together and have them adjusted by one trimmer.

AGC-O

The AGC-O module is an output limiting circuit with a fixed compression ratio of ∞ : 1. The limiting level is programmable as a level measured in dB from full scale. The maximum output of the device is 0 dBFS. The AGC-O

FOUNDATION GA3216

module has its own twin level detector, with programmable attack and release time constants.

MS and MS2 Switches

There are two, two-pole Memory Select switches available on the Foundation GA3216, enabling users tremendous flexibility in switching between configurations. These switches may be either momentary or static as set up in ARKonline and are configurable to be either pull-up or pull-down through the setting tab in IDS. In programmable mode, the device must be set to pull-down.

Up to four memories can be configured in programmable or trimmer mode. Enabled (valid) memories must be sequential. For example, if three memories were required, memories A, B and C would be enabled. Memory A must always be valid. All memory select options are selectable via the ARKonline wizard.

In simple trimmer mode, there is one method for memory select. In this mode, when the telecoil is enabled, MS (Pin 13) switches the Foundation GA3216's input between the microphone and the telecoil using either a momentary or static switch, selectable using ARKonline.

There are four memory select modes available in programmable and multi-memory trimmer mode as follows:

- Momentary Switch on MS
- Momentary Switch on MS, Static Switch on MS2 (jump to last memory)
- Static Switch on MS and MS2
- Static Switch on MS, Static Switch on MS2 (jump to last memory)

Table 4. DYNAMIC EXAMPLE WITH FOUR VALID MEMORIES (T = momentary switch is toggled; 0 = OPEN; 1 = HIGH)

MS2	0	0	0	1	1	1	0	0	0	1	0	0	0	0	0	0
MS	0	T	T	0	T	T	0	T	T	0	0	T	T	T	T	T
Memory	A	B	C	D	D	D	C	A	B	D	B	C	A	B	C	A

Static Switch on MS and MS2

This mode uses two static switches to change memories. Table 5 describes which memory is selected depending on the state of the switches.

In this mode, it is possible to jump from any memory to any other memory simply by changing the state of both switches. If both switches are changed simultaneously, then the transition is smooth, otherwise, if one switch is changed and then the other, the part transitions to an intermediate memory before reaching the final memory.

The part starts in whatever memory the switches are selecting. If a memory is invalid, the part defaults to memory A.

Momentary Switch on MS

This mode uses a single momentary switch on MS (Pin 13) to change memories. Using this mode causes the part to start in memory A, and whenever the button is pressed, the next valid memory is loaded. When the user is in the last valid memory, a button press causes memory A to be loaded.

Example:

- If 4 valid memories: ABCDABCDA...
- If 3 valid memories: ABCABCA...
- If 2 valid memories: ABABA...
- If 1 valid memories: AAA...

Momentary Switch on MS, Static Switch on MS2 (Jump to Last Memory)

This mode uses a static switch on MS2 (Pin 14) and a momentary switch on MS (Pin 13) to change memories. If the static switch is OPEN, the part starts in memory A and it behaves like momentary, with the exception that the last valid memory is not used. If the static switch on MS2 is set to HIGH, the part automatically jumps to the last valid memory (occurs on startup or during normal operation). In this setup, the momentary switch's state is ignored. This prevents memory select beeps from occurring. When MS2 is set to OPEN, the part loads in the last select memory.

Example:

- If MS2 = OPEN and there are 4 valid memories: ABCABCA...
- If MS2 = OPEN and there are 3 valid memories: ABABA...
- If MS2 = HIGH and there are 4 valid memories: D...
- If MS2 = HIGH and there are 3 valid memories: C...

Table 5. MEMORY SELECTIONS USING MS and MS2

MS	MS2	Memory
OPEN	OPEN	A
HIGH	OPEN	B (if valid, otherwise A)
OPEN	HIGH	C (if valid, otherwise A)
HIGH	HIGH	D (if valid, otherwise A)

FOUNDATION GA3216

Static Switch on MS, Static Switch on MS2 (Jump to Last Memory)

This mode uses two static switches to change memories.

Unlike in the previous example, this mode switches to the last valid memory when the static switch on MS2 is HIGH. This means that this mode only uses a maximum of three memories (even if four valid memories are programmed). Table 6 describes which memory is selected depending on the state of the switches.

Table 6. MEMORY SELECTIONS USING MS and MS2 (Jump to Last Memory)

MS	MS2	Memory
OPEN	OPEN	A
HIGH	OPEN	B (if valid, otherwise A)
OPEN	HIGH	Last Valid Memory
HIGH	HIGH	Last Valid Memory

In this mode, it is possible to jump from any memory to any other memory simply by changing the state of both switches. If both switches are changed simultaneously, then the transition will be smooth, otherwise, if one switch is changed and then the other, the part transitions to an intermediate memory before reaching the final memory.

When MS2 is set HIGH, the state of the switch on MS is ignored. This prevents memory select beeps from occurring when switching MS when MS2 is HIGH.

The part starts in whatever memory the switches are selecting. If the device starts up in a memory other than A, and the memory beep tones are enabled, the device emits the corresponding tones for that memory. If a memory is invalid, the part defaults to memory A.

Audible Memory Change Indicator

The Foundation GA3216 Digital can be configured to produce tones to indicate a memory change.

Through ARKonline the Foundation GA3216 can be configured to either enable or disable the Memory Change Indicator. When the Memory Change Indicator is enabled, there is an option to have a single beep for each memory change or multiple-beeps.

The amplitude and frequency of the memory change tone can be selected independently from the Tone Generator settings and can be individually selected for each memory.

When the memory change multiple beep is enabled and the memory change tone is enabled, then during a memory change operation the selected tone beeps a code to indicate which memory has been selected. The beep sequence is 150 ms ON followed by a 150 ms OFF time between the beeps. The memory change beeping code is deciphered in Table 7.

Table 7. MEMORY CHANGE BEEPING CODE

Selected Memory	# Beeps
A	1
B	2
C	3
D	4

Tone Generator

The tone generator is capable of producing programmable tones. When the Tone Generator is enabled, the Foundation GA3216 Digital connects the output of the tone generator to the input of the D/A converter. The programmed tone is output until the Tone Generator is disabled. When disabled, the normal audio signal path is again connected. The tone generator produces a beep to indicate a memory select change, a Microphone/Telecoil selection change or to warn the user of low battery voltage.

NOTE: When the sampling frequency is set at 24 kHz, the tones scaled (e.g., a 1 kHz tone at 32 kHz sampling would be approximately 667 Hz at 24 kHz sampling).

Low Battery Indicator (Power-On / Power-Off)

During power-on, the Foundation GA3216 Digital is held in a reset state until V_b reaches a turn-on threshold, and the hybrid's internal control logic determines that the supply is stable. When this occurs the hybrid begins its power-on sequence.

When a low battery condition is detected, the Foundation GA3216 Digital sends out a series of 3 beeps (225 ms ON, 225 ms OFF, 225 ms ON, 225 ms OFF, 225 ms ON) to indicate the battery is low. This repeats every 5 minutes until the device reaches the turn-off threshold. The low battery indicator threshold is adjustable in ARKonline, between 1.0 V and 1.2 V.

If V_b drops below the turn-off threshold, then the Foundation GA3216 Digital is returned to its reset state and the audio output is muted.

There are four reset modes which are selectable through ARKonline.

The first is the shallow-reset mode which, during the power-on sequence, circuit starts when the supply voltage rises above the turn-ON threshold after shutdown. The device functions until the supply voltage drops below the turn-OFF threshold, but recovers when the device rises above the turn-ON threshold again.

The second is deep-reset mode which begins when the supply voltage rises above the turn-ON threshold after shutdown. Once the supply voltage drops below the turn-OFF threshold the Foundation GA3216 shuts down

FOUNDATION GA3216

and remains there until the supply voltage drops below approximately 0.3 V and subsequently rises above the turn-ON threshold after shutdown.

The third is a combination of these two modes, where the device starts up in shallow-reset mode initially, then changes over to deep-reset mode after 5 minutes.

The fourth option is to have the gain reduced as the battery voltage drops. When the supply falls below the low battery threshold the low battery tones will be emitted and the wideband gain will be reduced by 3 dB. As the battery voltage continues to drop, the low battery tones will continue and the wideband gain will continue to be reduced until the turn-OFF threshold is reached when the device will shut down.

Current Consumption

Typical current consumption of the Foundation GA3216 Digital, as stated in the Electrical Characteristics section, is measured at a specific configuration and settings. If lower current is desired, it can be achieved by selecting a 24 kHz sampling rate from the settings tab in IDS, reducing the system's bandwidth from 16 kHz to 12 kHz.

Software

Full software support is provided for every stage of development from design to manufacturing to fitting. For details, refer to the Getting Started with ARK Software Guide.

SDA Communication

The Foundation GA3216 Digital is programmed via the SDA pin using industry standard programming boxes. During parameter changes, the main audio signal path of the hybrid is temporarily disabled and replaced with a low gain *bypass path* to avoid the generation of disturbing audio transients. Once the changes are complete, the main audio path is re-activated.

Any changes made during programming are lost at power-off unless they are explicitly burned to EEPROM memory.

Power Management

The Foundation GA3216 Digital was designed to accommodate high power applications. AC ripple on the supply can cause instantaneous reduction of the battery's voltage, potentially disrupting the circuit's function. The Foundation GA3216 has a separate power supply and ground connection for the output stage. This enables hearing instrument designers to accommodate external RC filters to minimize any AC ripple from the supply line. Reducing this AC ripple greatly improves the stability of the circuit and prevents unwanted reset of the circuit caused by spikes on the supply line.

For more information on properly designing a filter to reduce supply ripple, refer to the Using DSP Hybrids in High Power Applications Initial Design Tips information note.

FOUNDATION GA3216

Table 8. PAD POSITION AND DIMENSIONS

Pad No.	Pad Position		Pad Dimensions	
	X	Y	Xdim (mil)	Ydim (mil)
1	0	0	20	24
2	27	-1.75	18	27.5
3	53	-1.75	18	27.5
4	79	-1.75	18	27.5
5	105	-1.75	18	27.5
6	131	-1.75	18	27.5
7	157.5	-1.75	19	27.5
8	154	-34.25	26	21.5
9	154	-62.25	26	18.5
10	154	-88.75	26	18.5
11	122	-84.25	22	27.5
12	92.5	-84.25	21	27.5
13	63.5	-84.25	21	27.5
14	34.5	-84.25	21	27.5
15	3	-86.5	26	23
16	3	-57.25	26	19.5
17	3	-29.75	26	19.5
18	39.5	-45.25	31	20.5
19	78.5	-45.25	31	20.5
20	117.5	-45.25	31	20.5
Pad No.	X	Y	Xdim (mm)	Ydim (mm)
1	0	0	0.508	0.610
2	0.686	-0.044	0.457	0.699
3	1.346	-0.044	0.457	0.699
4	2.007	-0.044	0.457	0.699
5	2.667	-0.044	0.457	0.699
6	3.327	-0.044	0.457	0.699
7	4.001	-0.044	0.483	0.699
8	3.912	-0.870	0.660	0.546
9	3.912	-1.581	0.660	0.470
10	3.912	-2.254	0.660	0.470
11	3.099	-2.140	0.559	0.699
12	2.350	-2.140	0.533	0.699
13	1.613	-2.140	0.533	0.699
14	0.876	-2.140	0.533	0.699
15	0.076	-2.197	0.660	0.584
16	0.076	-1.454	0.660	0.495
17	0.076	-0.756	0.660	0.495
18	1.003	-1.149	0.787	0.521
19	1.994	-1.149	0.787	0.521
20	2.985	-1.149	0.787	0.521

FOUNDATION GA3216

PACKAGE DIMENSIONS

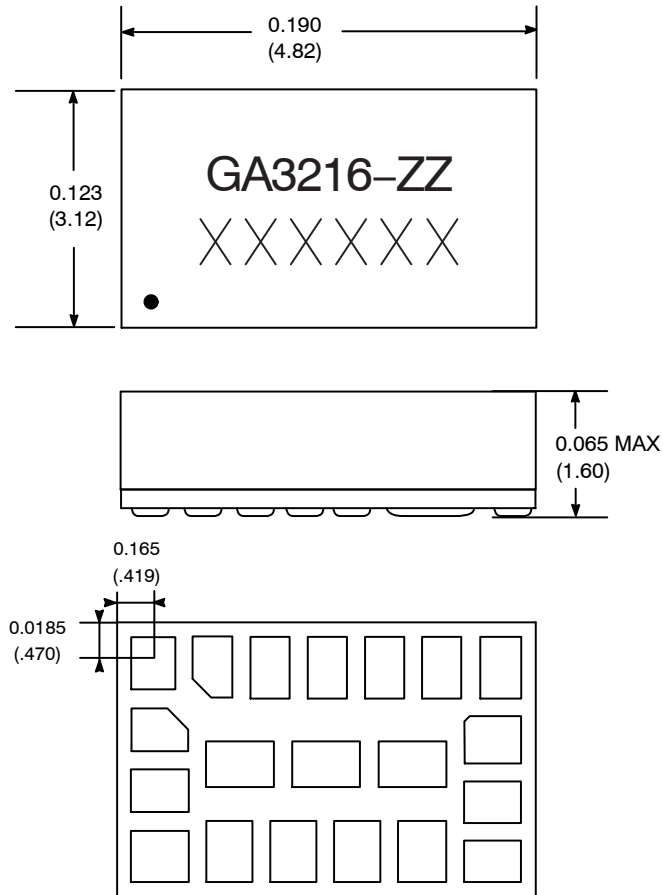

Dimension units are in inches.

Dimensions in parentheses are in millimeters, converted from inches and include minor rounding errors.

1.000 inches = 25.4 mm

Dimension tolerances: ± 0.005 (± 0.13) unless otherwise stated.

● = location of Pin 1

RoHS compliant hybrid, MSL#4, 240°C peak reflow, SAC305

Non-RoHS compliant hybrid, MSL#3, 218°C peak reflow, 60Sn/40Pb for external solder conditions

This Hybrid is designed for either point-to-point manual soldering or for reflow according to ON Semiconductor's reflow process.

HRX is a trademark of Semiconductor Components Industries, LLC.

thinSTAX, FOUNDATION, PARAGON, and ARKonline are registered trademarks of Semiconductor Components Industries, LLC.

ON Semiconductor and  are registered trademarks of Semiconductor Components Industries, LLC (SCILLC). SCILLC reserves the right to make changes without further notice to any products herein. SCILLC makes no warranty, representation or guarantee regarding the suitability of its products for any particular purpose, nor does SCILLC assume any liability arising out of the application or use of any product or circuit, and specifically disclaims any and all liability, including without limitation special, consequential or incidental damages. "Typical" parameters which may be provided in SCILLC data sheets and/or specifications can and do vary in different applications and actual performance may vary over time. All operating parameters, including "Typicals" must be validated for each customer application by customer's technical experts. SCILLC does not convey any license under its patent rights nor the rights of others. SCILLC products are not designed, intended, or authorized for use as components in systems intended for surgical implant into the body, or other applications intended to support or sustain life, or for any other application in which the failure of the SCILLC product could create a situation where personal injury or death may occur. Should Buyer purchase or use SCILLC products for any such unintended or unauthorized application, Buyer shall indemnify and hold SCILLC and its officers, employees, subsidiaries, affiliates, and distributors harmless against all claims, costs, damages, and expenses, and reasonable attorney fees arising out of, directly or indirectly, any claim of personal injury or death associated with such unintended or unauthorized use, even if such claim alleges that SCILLC was negligent regarding the design or manufacture of the part. SCILLC is an Equal Opportunity/Affirmative Action Employer. This literature is subject to all applicable copyright laws and is not for resale in any manner.

PUBLICATION ORDERING INFORMATION

LITERATURE FULFILLMENT:

Literature Distribution Center for ON Semiconductor
P.O. Box 5163, Denver, Colorado 80217 USA

Phone: 303-675-2175 or 800-344-3860 Toll Free USA/Canada

Fax: 303-675-2176 or 800-344-3867 Toll Free USA/Canada

Email: orderlit@onsemi.com

N. American Technical Support: 800-282-9855 Toll Free
USA/Canada

Europe, Middle East and Africa Technical Support:

Phone: 421 33 790 2910

Japan Customer Focus Center

Phone: 81-3-5773-3850

ON Semiconductor Website: www.onsemi.com

Order Literature: <http://www.onsemi.com/orderlit>

For additional information, please contact your local
Sales Representative