

FX806A AUDIO PROCESSOR

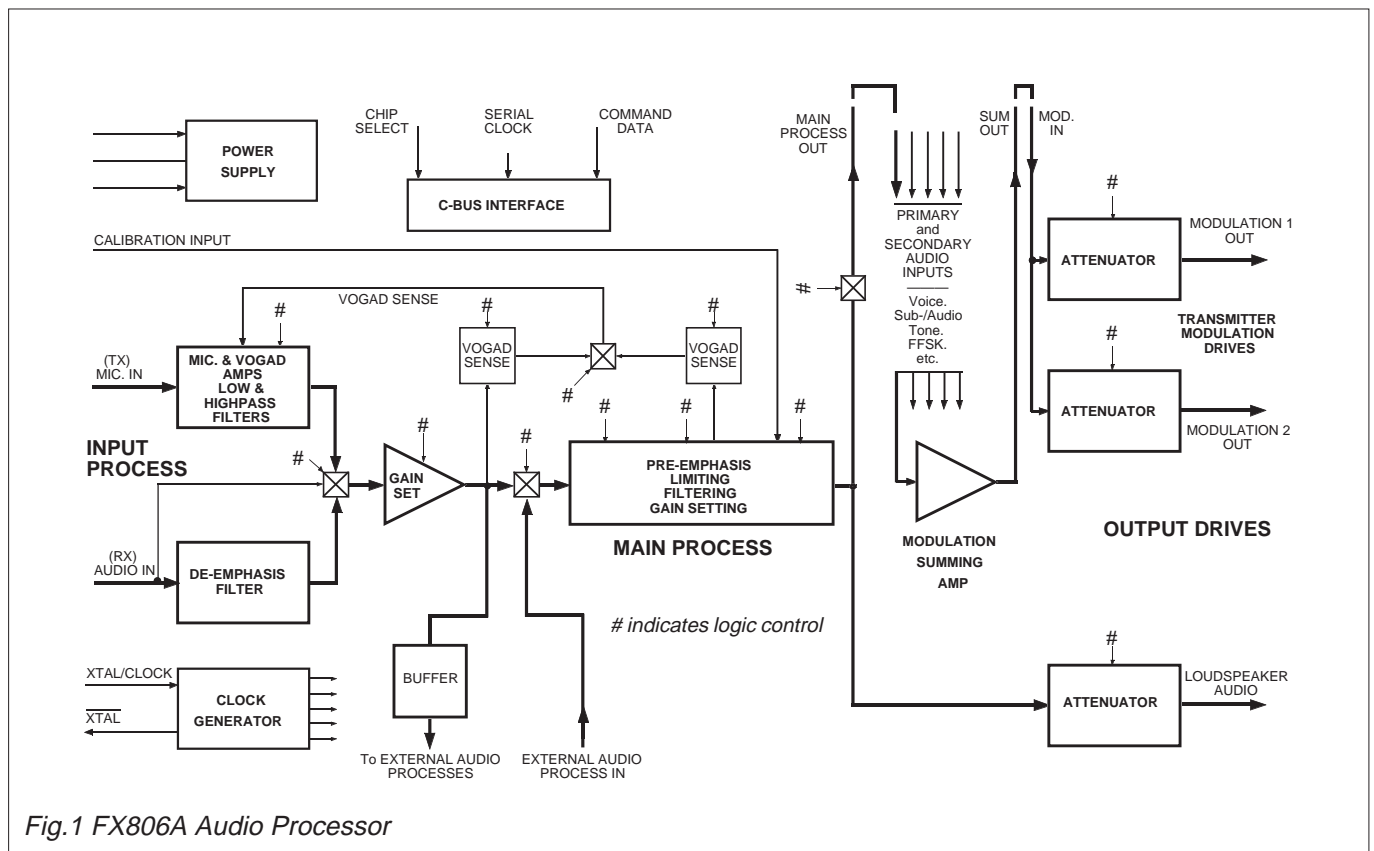

Fig.1 FX806A Audio Processor

Brief Description

Intended primarily to operate as the "Audio Terminal" of Radio Systems using the DBS 800 Digitally-integrated Baseband System, the FX806A is a PMR Audio Processor which meets EIA and CEPT audio specifications. Using a unique filter line-up, the FX806A offers lower distortion versus modulation level figures than conventional filter/limiter configurations.

The FX806A is a half-duplex device whose signal paths and level-setting elements are dynamically configured and adjusted by digital information sent from the Radio μ Controller using "C-BUS" hardware and software protocol.

Figure 5 shows a complete functional block diagram of the FX806A signal paths which can be viewed as 3 sections:

● Input Process

Selectable transmit or receive input paths.

The transmit path with low-noise input and VOGAD amplifiers and bandpass filtered stages provides good signal-to-noise performance at low input levels and minimum distortion for high-drive modulation signals.

De-emphasis is software selectable at the Rx Audio Input for FM or PM radio configurations.

This initial audio, after in-line gain adjustment, is available for switching to either external audio processes (such as scrambling) or internally to the Main Process stages.

● Main Process

Conditioning for Input or External Process signals with gain/pre-emphasis, high and lowpass switched capacitor filters and a transmitter deviation limiter. The Main Process Output may be switched to V_{BIAS} .

● Summation and Output Drives

Main "voice audio" from the Main Process is combined with signalling and data from other DBS 800 facilities, to provide the composite (in and outband) signal for the digitally adjustable Transmitter Modulation Drives. Received audio is level (volume) adjusted for output to loudspeaker circuitry.

Signal-level stability and therefore output accuracy, of the FX806A is maintained by a voltage-controlled gain system (VOGAD) with specific gain sensors that are selected automatically by the Internal/External Mode Command. The VOGAD system permits high deviation with low distortion. This is achieved by reducing the path gain (and so reducing the distortion introduced by the Peak Deviation limiter) when the input signal is large.

Signal levels can be controlled to provide 'dynamic-compensation' for such factors as temperature drift, VCO non-linearity, etc.

FX806A audio output stages can be completely disabled or the whole microcircuit placed into a "Powersave" mode, leaving only clock and "C-BUS" circuitry active.

The FX806A is a low-power, 5-volt CMOS integrated circuit and is available in 24-pin DIL cerdip and 24-pin/lead plastic SMD packages.

Pin Number Function

FX806A J/LG/LS	
1	Xtal: The output of the on-chip clock oscillator. External components are required at this output when a Xtal circuit is employed. See Figure 2, INSET 2.
2	Xtal/clock: The input to the on-chip clock oscillator inverter. A Xtal or externally derived clock should be connected here. See Figure 2, INSET 2. This clock provides timing for on-chip elements, filters etc.
3	Serial Clock: The “C-BUS,” serial data loading clock input. This clock, produced by the μ Controller, is used for transfer timing of Command Data to the Audio Processor. See Timing diagrams and System Support Document.
4	Command Data: The “C-BUS,” serial data input from the μ Controller. Command Data is loaded to this device in 8-bit bytes, MSB (B7) first, and LSB (B0) last, synchronized to the Serial Clock. The Command/Data instruction is acted upon at the end of loading the whole instruction. Command information is detailed in Tables 1, 2, 3, 4 and 5. See Timing diagrams and System Support Document.
5	Chip Select (\overline{CS}): The “C-BUS,” data loading control function. This input is provided by the μ Controller. Command Data transfer sequences are initiated, completed or aborted by the \overline{CS} signal. See Timing diagrams and System Support Document.
6	VOGAD Out: The output of the relevant VOGAD sensor. This output, with external attack and decay setting components, should be connected as in Figures 2 and 3, to the VOGAD In pin.
7	Rx Audio In: The audio input to the FX806A from the radio receiver's demodulator circuits. This input, which requires to be a.c. coupled with capacitor C_{12} , is selected by a Control Command bit.
8	VOGAD In: The gain control signal from the selected VOGAD sensor (VOGAD Out) to the “Input Process” Voltage Controlled Amplifier. VOGAD operation is enabled via a Mode Command (Bit5). Individual sensors, automatically selected, permit gain control from either the Input Process or an external process. External attack and decay setting components should be applied as recommended in Figures 2 and 3.
9	V_{BIAS}: The output of the on-chip analogue circuitry bias system, held internally at $V_{DD}/2$. This pin should be decoupled to V_{SS} by a capacitor C_{10} . See Figure 2.
10	Mic In (+): The non-inverting input to the microphone Op-Amp. This input requires external components for Op-Amp gain/attenuation setting as shown in Figure 2, INSET 1.
11	Mic In (-): The inverting input to the microphone Op-Amp. This input requires external components for Op-Amp gain/attenuation setting as shown in Figure 2, INSET 1.
12	V_{SS}: Negative supply rail (GND).

Pin Number Function

FX806A J/LG/LS	
13	<p>Mic Out: The output of the microphone Op-Amp, used with the Mic In (–) input to provide the required gain/attenuation using external components as shown in Figure 2. The external components shown are to assist in the use of this amplifier with either inverting or non-inverting inputs. During Powersave (Volume Command) this output is placed at V_{SS}.</p>
14	<p>Processed Audio In: The input to the device from such external audio processes as Voice Store and Retrieve or Frequency Domain Scrambling. This input, which requires to be a.c. coupled with a capacitor, C_{13}, is selected by a Mode Command bit.</p>
15	<p>External Audio Process: The buffered output of the Input Processing stage. For further external audio processing prior to re-introduction at the Processed Audio In pin.</p>
16	<p>CALibration Input: A unique input, intended to be used for dynamic balancing of the modulator drives and for measuring Deviation Limiter levels. A CUE (beep) input from the FX803 Audio Tone Processor can be entered on this line. This input is selected via a Mode Command bit (11_H) and is self-biased.</p>
17	<p>Main Process Out: The output of the Main Process stage. This output is summed with additional system inputs as required (Audio, Sub-Audio Signalling, FFSK – See System Overview) in the on-chip Modulation Summing Amplifier. External components as shown in Figure 2 should be used as required.</p>
18	<p>Sum In: The input and output terminals of the on-chip Modulation Summing Amplifier. External components are required for input signals, with gain/attenuation setting as shown in Figure 2. For single-signal, no-gain requirements, Main Process Out may be linked directly to Modulation In.</p>
19	<p>Sum Out:</p>
20	<p>Modulation In: The final, composite modulating signal to VCO (Mod 1) and Reference (Mod 2) Output Drives.</p>
21	<p>Audio Output: The processed audio signal output intended as a received audio (volume) output. Though normally used in the Rx mode, operation in Tx is permitted. The output level of this attenuator is controlled via a Volume Set command. During Powersave this output is placed at V_{SS}.</p>
22	<p>Modulation 1 Drive: The drive to the radio modulator Voltage Controlled Oscillator (VCO), from the composite audio summing stage.</p>
23	<p>Modulation 2 Drive: The drive to the radio modulator Reference Oscillator, from the composite audio summing stage. NOTE: These VCO output attenuators are individually adjustable using the Modulator Levels command. During Powersave these outputs are placed at V_{SS}.</p>
24	<p>V_{DD}: Positive supply rail. A single, stable +5 volt supply is required. Levels and voltages within the Audio Processor are dependant upon this supply.</p>

Analogue Application Information

External Components

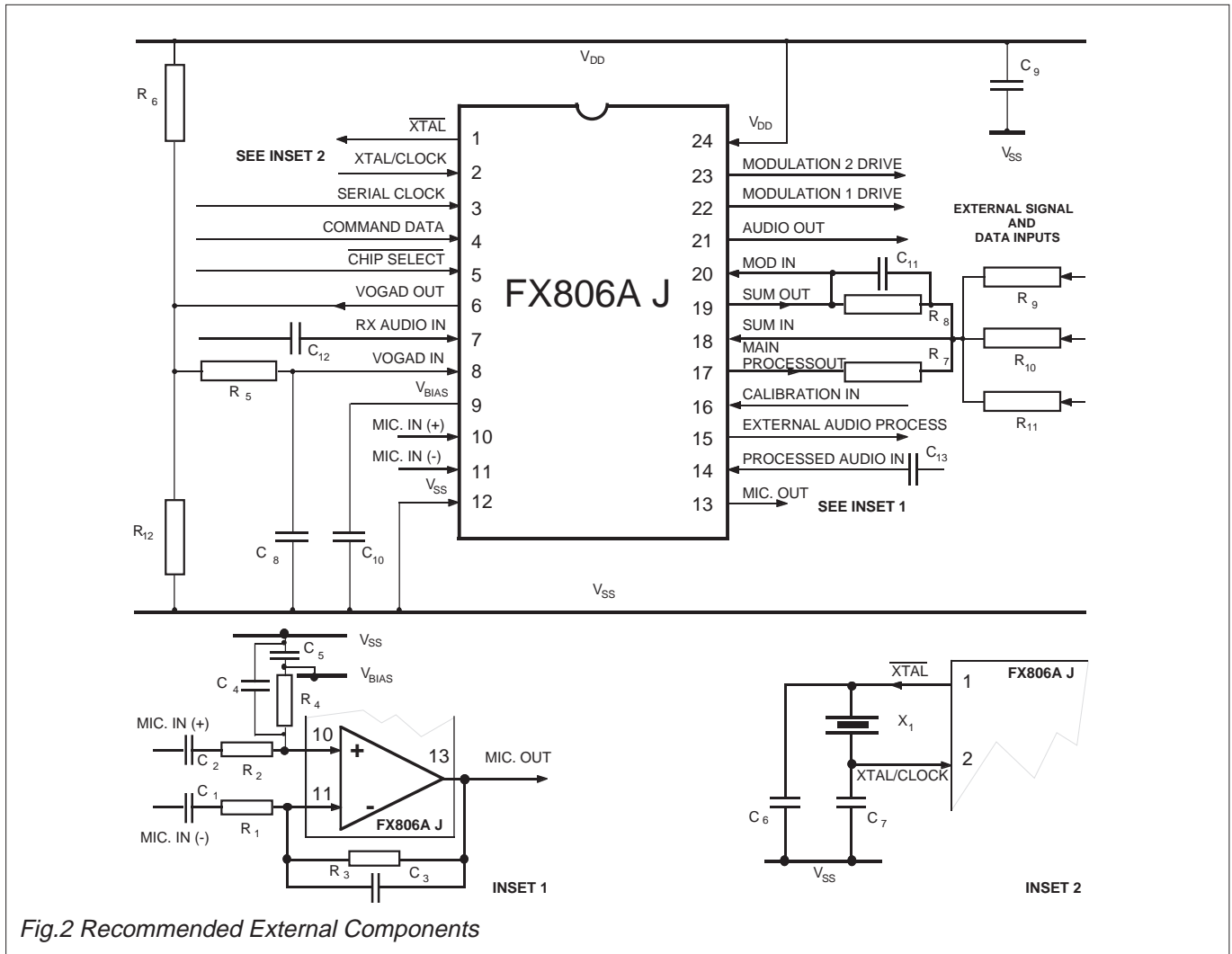

Fig.2 Recommended External Components

Component	Value	Component	Value	Component	Value
R ₁	= 10.0kΩ	R ₁₀	= 100kΩ	C ₇	= 5 – 65pF
R ₂	= 10.0kΩ	R ₁₁	= 100kΩ	C ₈	= 1.0μF
R ₃	= 20.0kΩ	R ₁₂	= 2.2MΩ	C ₉	= 1.0μF
R ₄	= 20.0kΩ	C ₁	= 470nF	C ₁₀	= 1.0μF
R ₅	= 10.0kΩ	C ₂	= 470nF	C ₁₁	= 22pF
R ₆	= 2.2MΩ	C ₃	= 270pF	C ₁₂	= 100nF
R ₇	= 100kΩ	C ₄	= 270pF	C ₁₃	= 10.0nF
R ₈	= 100kΩ	C ₅	= 0.1μF	X ₁₃	= 4.0MHz
R ₉	= 100kΩ	C ₆	= 33pF		

Tolerance: R = ±10%. C = ± 20%

Notes

To demonstrate the versatility of the Mic. inputs, Input Op-Amp gain/attenuation components for a voltage gain of 6.0dB are shown (INSET 1) in a differential configuration. Components for a single (+ or -) input may be employed.

Resistor values R₇ to R₁₁ (summation components) are dependant upon application and configuration requirements.

Xtal circuit capacitors C₆ (C_D) and C₇ (C_C) shown (INSET 2) are recommended in accordance with *CML Application Note D/XT/2 December 1991*. Circuit drive and drain resistors are incorporated on-chip.

Operation of any CML microcircuit without a Xtal or clock input may cause device damage. To minimise damage in the event of a Xtal/drive failure, it is recommended that the power rail (V_{DD}) is fitted with a current limiting device (resistor or fast reaction fuse).

VOGAD Components Calculations – Figures 2 and 3

Provided R₅ >> 1.0kΩ and R₆ = R₁₂ >> R₅

Then:

$$\text{Attack Time (T}_A\text{)} = R_5 \times C_8$$

$$\text{Decay Time (T}_D\text{)} = \frac{R_6 \times C_8}{2}$$

Analogue Application Information

The Gain Control System

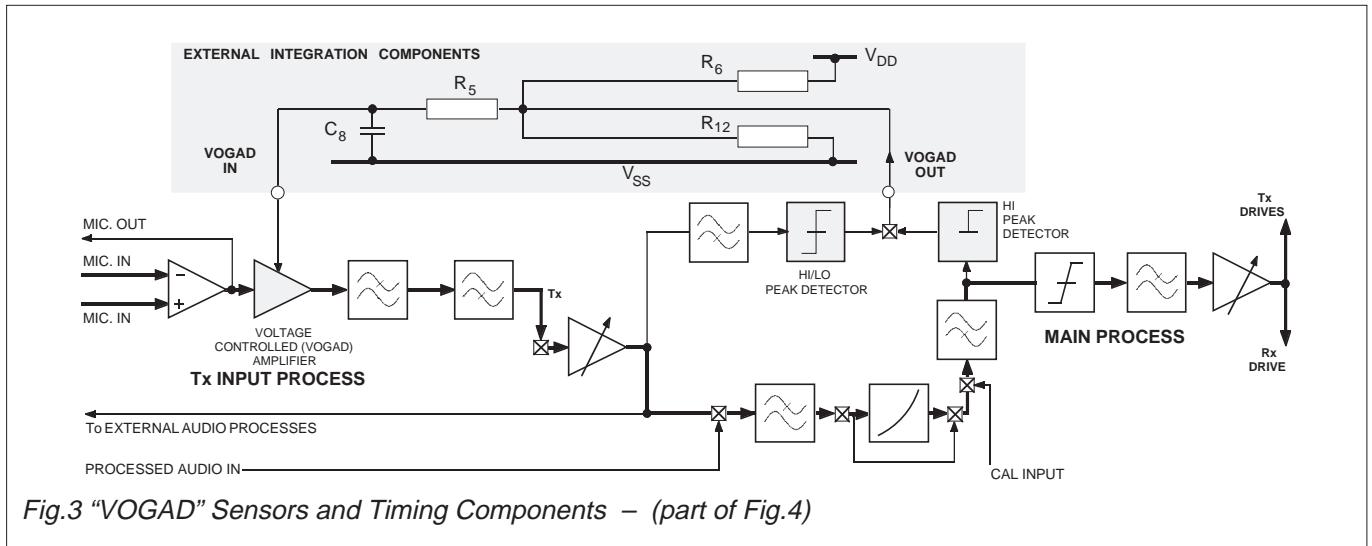

Tx gain control of the FX806A is by 1 of 2 selectable signal peak detectors whose output is fed via external integrating components to the Voltage Controlled Amplifier positioned in the Tx Input Process Path.
 The integrated level to the VOGAD In pin causes the Voltage Controlled Amplifier gain to be reduced. VOGAD attack and decay calculations are described at the foot of the preceding page.

The FX806A automatically chooses the appropriate peak detector when the signal path is set by a Mode Command. The Hi/Lo Peak Detector is employed when external audio processes are used. The Hi Peak Detector is employed when external audio processes are not used.

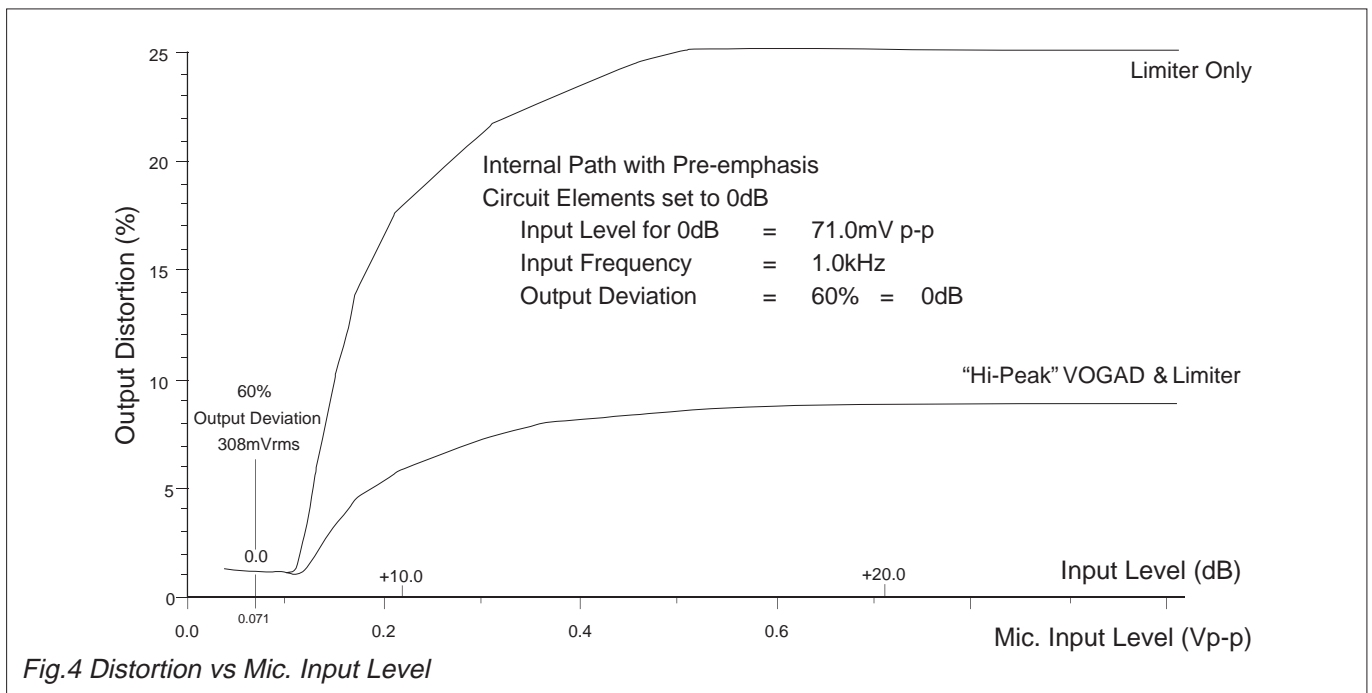

Suggested Calibration Methods

To effectively null all internal microcircuit tolerances, the following initial calibration routine is suggested:

Tx Calibration : From Mic. In to Modulator Drives Out

- Disable Peak Detectors (Mode Command).
- Set Transmitter Drives to 0dB (Mod Levels Set).
- Pre-emphasis may be employed as required (Control Command).
- Set Input Level Amp to 0dB (Control Command).

- (1) Mic. In = 250mVrms at 1kHz; Set Process Gain Amp for output of 1440mV p - p (100% deviation).
- (2) With Process Gain Amp set as (1); Mic In = 25mVrms at 1kHz, set Input Level Amp for output level of 308 mVrms (60% deviation).

Rx Calibration: From Rx Audio In to Audio Output

- Set Audio Output Drive to 0dB (Volume Set).
- Leave Process Gain Amp set as In (1) (above).
- (3) With Rx Audio In level of between 154mVrms and 308mVrms (see Specification page), at 1kHz, set the Input Level Amp for an output level of 308mVrms.

PLMR Audio Processor

Explanatory Block Diagram

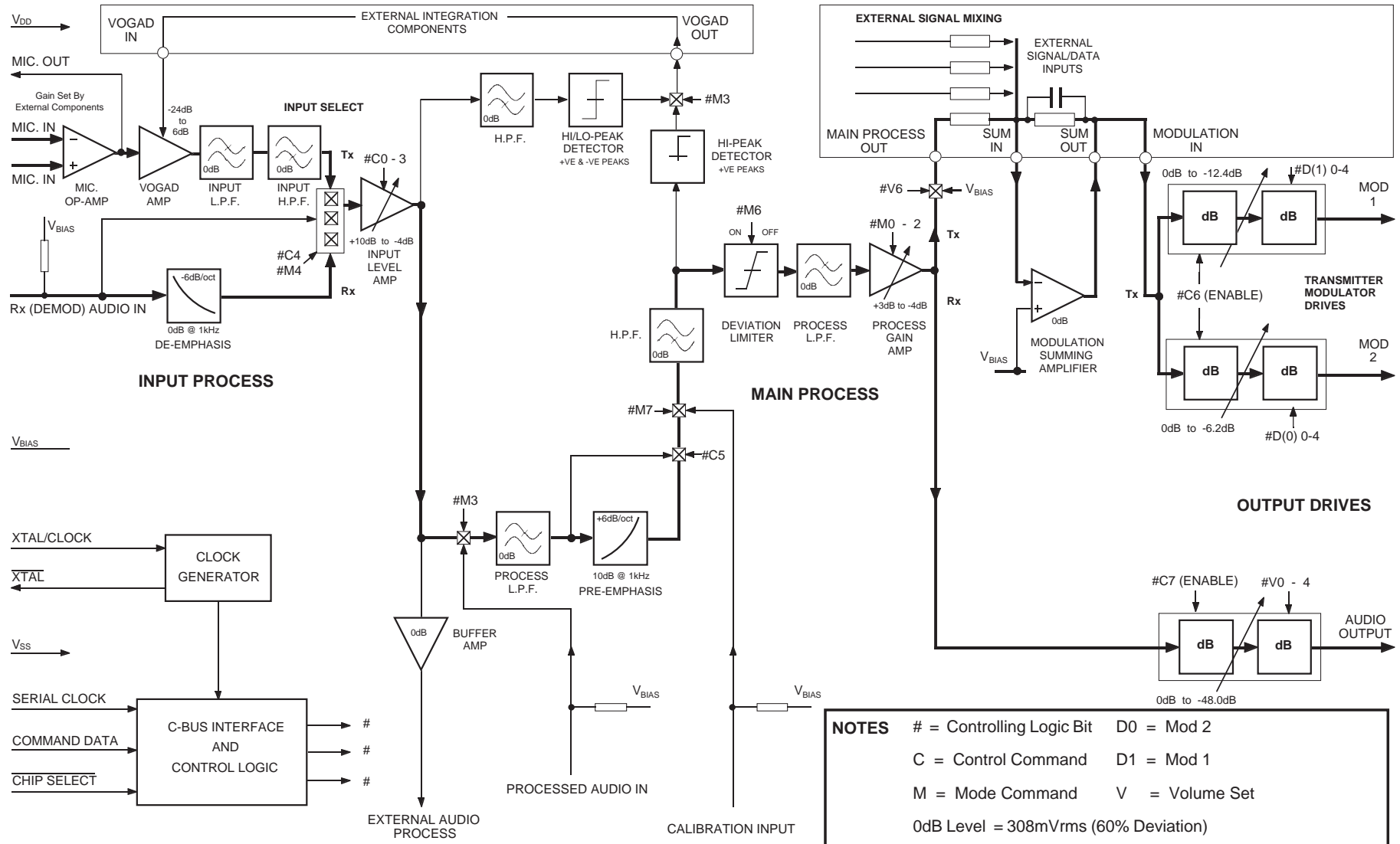

Fig.5 PLMR Audio Processor – Facilities

Controlling Protocol

Control of the functions and levels within the FX806A PLMR Audio Processor is by a group of Address/Commands and appended data instructions from the system μ Controller to set/adjust the functions and elements of the FX806A. The use of these instructions is detailed in the following paragraphs and tables.

Command Assignment	Address/Command (A/C) Byte				Command Data	Table						
	Hex	Binary		LSB								
General Reset	01	0	0	0	0	1						
Control Command	10	0	0	0	1	0	0	0	+	1 byte	2	
Mode Command	11	0	0	0	1	0	0	0	1	+	1 byte	3
Mod. Levels Set	12	0	0	0	1	0	0	1	0	+	2 bytes	4
Volume Set	13	0	0	0	1	0	0	1	1	+	1 byte	5

Table 1 "C-Bus" Address/Commands

In "C-BUS" protocol the FX806A is allocated Address/Command (A/C) values 10_H to 13_H. "C-BUS" Command, Mode, Modulation and Volume assignments and data requirements are given in Table 1 and illustrated in Figure 5 (Main Block Diagram). Each instruction consists of an Address/Command (A/C) byte followed by a data instruction formulated from the following tables.

Commands and Data are only to be loaded in the group configurations detailed, as the "C-BUS" interface recognises the first byte after $\overline{\text{Chip Select}}$ (logic "0") as an Address/Command.

Function or Level control data, which is detailed in Tables 2, 3, 4 and 5, is acted upon at the end of the loaded instruction.

Upon Power-Up the value of the "bits" in this device will be random (either "0" or "1"). A General Reset Command (01_H) will be required. This command is provided to "reset" all devices on the "C-BUS" and has the following effect on the FX806A.

Control Address Command	Loaded as 00 _H
Mode Address Command	Loaded as 00 _H
Volume Set	Loaded as 00 _H

Control Command *(Preceded by A/C 10_H)*

Setting				Control Bits
MSB Bit 7				Transmitted First Audio Output (Rx)
0				Disabled
1				Enabled
6				Modulation Drives
0				Disabled
1				Enabled
5				Pre-Emphasis
0				By-Pass
1				Enabled
4				Input Select
0				Rx Audio In
1				Mic. In
3	2	1	0	Input Level Set
0	0	0	0	Input Amp Disabled
0	0	0	1	-4.0dB
0	0	1	0	-3.0dB
0	0	1	1	-2.0dB
0	1	0	0	-1.0dB
0	1	0	1	0dB
0	1	1	0	1.0dB
0	1	1	1	2.0dB
1	0	0	0	3.0dB
1	0	0	1	4.0dB
1	0	1	0	5.0dB
1	0	1	1	6.0dB
1	1	0	0	7.0dB
1	1	0	1	8.0dB
1	1	1	0	9.0dB
1	1	1	1	10.0dB

Table 2 Control Commands

Mode Command *(Preceded by A/C 11_H)*

Setting			Mode Bits
MSB Bit 7			Transmitted First Drive Source
0			Signals
1			Calibration
6			Deviation Limiter
0			Disabled
1			Enabled
5			VOGAD
0			Disabled
1			Enabled
4			De-Emphasis
0			Enabled
1			By-Passed
3			Signal Select
0			Internal
1			External
2	1	0	Process Gain Set
0	0	0	-4.0dB
0	0	1	-3.0dB
0	1	0	-2.0dB
0	1	1	1.0dB
1	0	0	0dB
1	0	1	1.0dB
1	1	0	2.0dB
1	1	1	3.0dB

Table 3 Mode Commands

Modulator Levels

(Preceded by A/C12_H)

Setting					Modulator Drives	
Byte 1					First byte for transmission	
MSB						
7	6			5		
0	0			0		Must be "0"
4	3	2	1	0		
0	0	0	0	0		Mod. 1 Attenuation
0	0	0	0	1		12.4dB
0	0	0	0	1		12.0dB
0	0	0	1	0		11.6dB
0	0	0	1	1		11.2dB
0	0	1	0	0		10.8dB
0	0	1	0	1		10.4dB
0	0	1	1	0		10.0dB
0	0	1	1	1		9.6dB
0	1	0	0	0		9.2dB
0	1	0	0	1		8.8dB
0	1	0	1	0		8.4dB
0	1	0	1	1		8.0dB
0	1	1	0	0		7.6dB
0	1	1	0	1		7.2dB
0	1	1	1	0		6.8dB
0	1	1	1	1		6.4dB
1	0	0	0	0		6.0dB
1	0	0	0	1		5.6dB
1	0	0	1	0		5.2dB
1	0	0	1	1		4.8dB
1	0	1	0	0		4.4dB
1	0	1	0	1		4.0dB
1	0	1	1	0		3.6dB
1	0	1	1	1		3.2dB
1	1	0	0	0		2.8dB
1	1	0	0	1		2.4dB
1	1	0	1	0		2.0dB
1	1	0	1	1		1.6dB
1	1	1	0	0		1.2dB
1	1	1	0	1		0.8dB
1	1	1	1	0		0.4dB
1	1	1	1	1		0dB
Byte 0					Last byte for transmission	
MSB						
7	6			5		
0	0			0		Must be "0"
4	3	2	1	0		
0	0	0	0	0		Mod. 2 Attenuation
0	0	0	0	1		6.2dB
0	0	0	0	1		6.0dB
0	0	0	1	0		5.8dB
0	0	0	1	1		5.6dB
0	0	1	0	0		5.4dB
0	0	1	0	1		5.2dB
0	0	1	1	0		5.0dB
0	0	1	1	1		4.8dB
0	1	0	0	0		4.6dB
0	1	0	0	1		4.4dB
0	1	0	1	0		4.2dB
0	1	0	1	1		4.0dB
0	1	1	0	0		3.8dB
0	1	1	0	1		3.6dB
0	1	1	1	0		3.4dB
0	1	1	1	1		3.2dB
1	0	0	0	0		3.0dB
1	0	0	0	1		2.8dB
1	0	0	1	0		2.6dB
1	0	0	1	1		2.4dB
1	0	1	0	0		2.2dB
1	0	1	0	1		2.0dB
1	0	1	1	0		1.8dB
1	0	1	1	1		1.6dB
1	1	0	0	0		1.4dB
1	1	0	0	1		1.2dB
1	1	0	1	0		1.0dB
1	1	0	1	1		0.8dB
1	1	1	0	0		0.6dB
1	1	1	0	1		0.4dB
1	1	1	1	0		0.2dB
1	1	1	1	1		0dB

Table 4 Modulator Drive Levels

Volume Set

(Preceded by A/C13_H)

Setting					Volume Set	
MSB					Transmitted First Main Process Out	
7	6			5		Enabled
0	0			0		Biased
0	0			1		
5					Powersave	
				0		Chip Enabled
				1		Powersaved
4	3	2	1	0		Volume Set Attenuation
0	0	0	0	0		Off
0	0	0	0	1		48.0dB
0	0	0	1	0		46.4dB
0	0	0	1	1		44.8dB
0	0	1	0	0		43.2dB
0	0	1	0	1		41.6dB
0	0	1	1	0		40.0dB
0	0	1	1	1		38.4dB
0	1	0	0	0		36.8dB
0	1	0	0	1		35.2dB
0	1	0	1	0		33.6dB
0	1	0	1	1		32.0dB
0	1	1	0	0		30.4dB
0	1	1	0	1		28.8dB
0	1	1	1	0		27.2dB
0	1	1	1	1		25.6dB
1	0	0	0	0		24.0dB
1	0	0	0	1		22.4dB
1	0	0	1	0		20.8dB
1	0	0	1	1		19.2dB
1	0	1	0	0		17.6dB
1	0	1	0	1		16.0dB
1	0	1	1	0		14.4dB
1	0	1	1	1		12.8dB
1	1	0	0	0		11.2dB
1	1	0	0	1		9.6dB
1	1	0	1	0		8.0dB
1	1	0	1	1		6.4dB
1	1	1	0	0		4.8dB
1	1	1	0	1		3.2dB
1	1	1	1	0		1.6dB
1	1	1	1	1		0dB

Table 5 Volume Set

Command Loading Address/Commands and data bytes must be loaded in accordance with the information given in Figure 6 (Timing).

The **Powersave** function is instigated by bit 5 of the Volume Set Command (Table 5).

During Powersave, all internal elements except the Clock Generator and "C-BUS" Interface are off, with the Mic Op-Amp and Output Drive stage outputs connected to V_{SS} .

Modulator Drives are controlled separately, but the whole two-byte Modulator Drive command must be loaded for each required adjustment.

Chip Select must be held at a logic "1" for the period t_{CSOFF} between transactions.

Command Loading and Timing

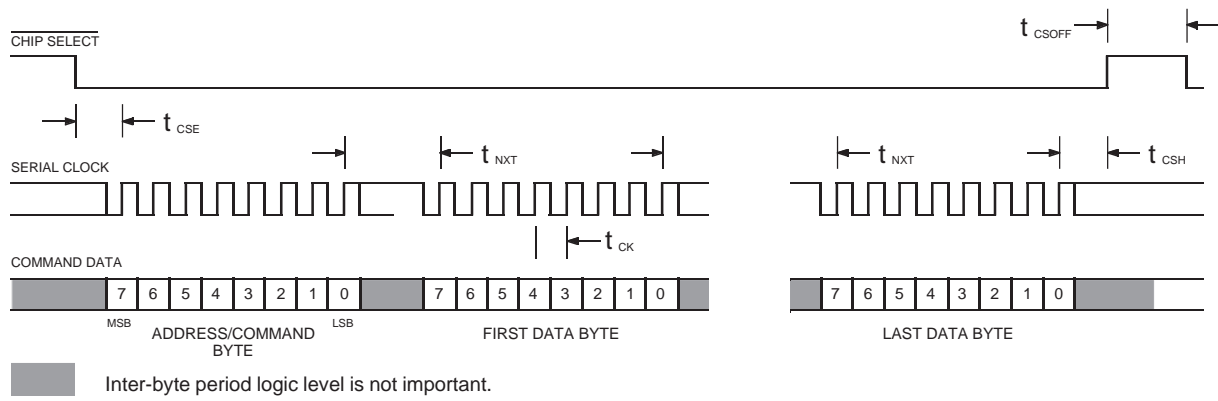

Fig.6 "C-BUS" Timing Information

Parameter	Min.	Typ.	Max.	Unit
t_{CSE}	2.0	–	–	μ S
t_{CSH}	4.0	–	–	μ S
t_{CSOFF}	2.0	–	–	μ S
t_{NXT}	4.0	–	–	μ S
t_{CK}	2.0	–	–	μ S

Notes

- (1) Command Data is transmitted to the peripheral MSB (bit7) first, LSB (bit0) last.
- (2) Data is clocked into the peripheral on the rising clock edge.
- (3) Loaded data instructions are acted upon at the end of each individual, loaded byte.
- (4) To allow for differing μ Controller serial interface formats, the FX806A will work with either polarity Serial Clock pulses.

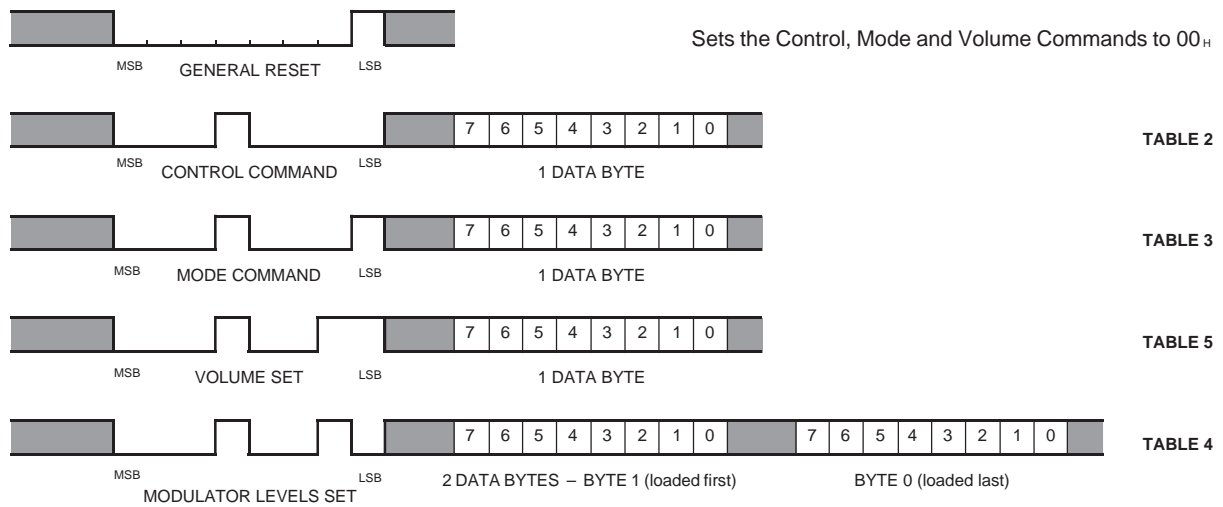

Fig.7 Examples of "Command Data" Configurations

To assist in rapid setting, the "quick-reference" guide below should be used together with Figure 5.

Control	A/C = 10_H	Modulator Levels	A/C = 12_H
Bit 7	Audio Out (Rx) Enable	Byte 1	
6	Modulator Drive Enable	Bit 7 – 5	"0"
5	Pre-Emphasis Enable	4 – 0	Mod 1 Attenuation (0 to 12.4dB)
4	Input Select (Rx/Tx)	Byte 2	
3 – 0	Input Level Set (-4dB to 10dB)	7 – 5	"0"
Mode	A/C = 11_H	4 – 0	Mod 2 Attenuation (0 to 6.2dB)
Bit 7	Drive Source	Volume Set	A/C = 13_H
6	Deviation Limiter Enable	Bit 7 – 6	"0"
5	VOGAD Enable	5	Powersave
4	De-Emphasis Enable	4 – 0	Volume Set Attenuation (0 to 48dB)
3	Signal Select		
2 – 0	Process Gain Set (-4dB to 3dB)		

Table 6 "Quick-Reference" to Command Allocations

Specification

Absolute Maximum Ratings

Exceeding the maximum rating can result in device damage. Operation of the device outside the operating limits is not implied.

Supply voltage		-0.3 to 7.0V
Input voltage at any pin (ref $V_{SS} = 0V$)		-0.3 to ($V_{DD} + 0.3V$)
Sink/source current (supply pins)		+/- 30mA
(other pins)		+/- 20mA
Total device dissipation @ $T_{AMB} 25^{\circ}C$		800mW Max.
Derating		10mW/ $^{\circ}C$
Operating temperature range:	FX806A J	-40 $^{\circ}C$ to +85 $^{\circ}C$ (cerdip)
	FX806A LG/LS	-40 $^{\circ}C$ to +85 $^{\circ}C$ (plastic)
Storage temperature range:	FX806A J	-55 $^{\circ}C$ to +125 $^{\circ}C$ (cerdip)
	FX806A LG/LS	-40 $^{\circ}C$ to +85 $^{\circ}C$ (plastic)

Operating Limits

All device characteristics are measured under the following conditions unless otherwise specified:

$V_{DD} = 5.0V$. $T_{AMB} = 25^{\circ}C$. Xtal/Clock $f_0 = 4.0MHz$. Audio Level 0dB ref: = 308mVrms @ 1kHz (60% deviation, FM).

Characteristics	See Note	Min.	Typ.	Max.	Unit
Static Values					
Supply Voltage		4.5	5.0	5.5	V
Supply Current (All Elements Enabled)		–	8.0	–	mA
(Maximum Powersave)		–	0.7	–	mA
“C-BUS” Interface					
Input Logic “1”		3.5	–	–	V
Input Logic “0”		–	–	1.5	V
Input Leakage Current (logic “1 or 0”)		-1.0	–	1.0	μA
Input Capacitance		–	–	7.5	pF
Dynamic Values					
Overall Performance					
Microphone Input	4, 5	–	25.0	–	mVrms
Rx Audio In	6, 5	154	–	308	mVrms
Output Drive Levels					
For 60% Deviation	5, 7	291	308	326	mVrms
For 100% Deviation	5, 7, 8	–	1,440	–	mV p - p
Passband Frequencies					
Passband Ripple	1	297	–	3000	Hz
	2	-2.0	–	0.5	dB
Stopband Attenuation					
	1, 3				
f = 150Hz		10.0	12.0	–	dB
f = 3400Hz		–	2.0	–	dB
f = 6000Hz		30.0	36.0	–	dB
f = 8000Hz to 20,000Hz		–	60.0	–	dB
Signal Path Noise					
Rx	11	–	-60.0	–	dBp
Rx	10	–	-55.0	–	dB
Tx	11	–	-50.0	–	dBp
Tx	10	–	-45.0	–	dB
Distortion		–	1.0	–	%
Circuit Elements – Figure 5					
Mic Amp or Mod Summation Amp					
Open Loop Gain		–	50.0	–	dB
Bandwidth		20.0	–	–	kHz
Input Impedance		10.0	–	–	M Ω
Output Impedance (Open Loop)		–	6.0	–	k Ω
(Closed Loop)		–	600	–	Ω
De-emphasis					
Slope		–	-6.0	–	dB/oct.
Gain (at 1.0kHz)		–	0	–	dB
Input Impedance		–	500	–	k Ω
Voltage Controlled Gain Amp					
Gain (Non-Compressing)	5	–	6.0	–	dB
(Full Compression)		–	-24.0	–	dB
VOGAD In Input Impedance		–	10.0	–	M Ω

Specification.....

Characteristics	See Note	Min.	Typ.	Max.	Unit
VOGAD Peak Detectors					
Output Impedance - Logic "1" (Compress)		–	1.0	–	kΩ
- Logic "0"		–	10.0	–	MΩ
Hi/Lo Peak Detector Thresholds		–	1,300	–	mV p - p
Hi Peak Detector Threshold		–	650	–	mV +ve pk
Input (Low + Highpass) Filter					
Gain (at 1.0kHz)		-1.0	0	1.0	dB
Input Level Amp					
Nominal Adjustment Range		-4.0		10.0	dB
Error of any Setting		-1.0	–	1.0	dB
Step Size		0.75	1.0	1.25	dB
External Audio Buffer					
Gain		-0.1	0	0.1	dB
Pre-emphasis (Main Process and VOGAD)					
Slope		–	6.0	–	dB/oct.
Gain (at 1.0kHz)		–	10.0	–	dB
Process Highpass Filter					
Gain (at 1.0kHz)		-1.0	0	1.0	dB
Deviation Limiter					
Threshold		–	1,300	–	mV p - p
Gain		-0.5	–	0.5	dB
Process Lowpass Filter					
Gain (at 1.0kHz)		-1.0	0	1.0	dB
Process Gain Amp					
Nominal Adjustment Range		-4.0		3.0	dB
Error of any Setting		-0.5	–	0.5	dB
Step Size		0.75	1.0	1.25	dB
Output Impedance		–	600	–	Ω
Transmitter Modulator Drives					
Input Impedance		–	15.0	–	kΩ
Mod.1 Attenuator					
Nominal Adjustment Range		0		12.4	dB
Error of any Setting		-1.0	–	1.0	dB
Step Size		0.2	0.4	0.6	dB
Output Impedance		–	600	–	Ω
Mod.2 Attenuator					
Nominal Adjustment Range		0		6.2	dB
Error of any Setting		-0.6	–	0.6	dB
Step Size		0.1	0.2	0.3	dB
Output Impedance		–	600	–	Ω
Audio Output Attenuator					
Nominal Adjustment Range		0		48.0	dB
Error of any Setting		-1.5	–	1.5	dB
Step Size		–	1.6	–	dB
Output Impedance		–	600	–	Ω
Miscellaneous Impedances					
Processed Audio Input		–	500	–	kΩ
Calibration Input		–	500	–	kΩ
External Process Out		–	100	–	Ω
Rx with De-Emphasis By-Pass		–	25.0	–	kΩ

Notes

- Between Mic. or Rx inputs to Modulator or Audio outputs.
- The deviation from the ideal overall response that includes the pre- or de-emphasis slope.
- Excluding the effect of the pre- or de-emphasis slope.
- Producing an output of 0dB with the Mic. Op-Amp set to 6dB (as shown in Figure 2) and the Modulator Drives set to 0dB.
- With Output Drives set to 0dB and the system calibrated, as described in the Application pages.
- Input level range for 0dB output, by adjustment of the Input Level Amp.
- It is recommended that these output levels will produce 60% or 100% deviation in the transmitter.
- With the microphone input level 20dB above the level required to produce 0dB at the Output Drives.
- Using external components recommended in Figure 2.
- In a 30kHz bandwidth.
- dBp = Psophometrically weighted measurement.

Package Outlines

The FX806A is available in the package styles outlined below. Mechanical package diagrams and specifications are detailed in Section 10 of this document.

Pin 1 identification marking is shown on the relevant diagram and pins on all package styles number anti-clockwise when viewed from the top.

FX806A J 24-pin cerdip DIL (J4)

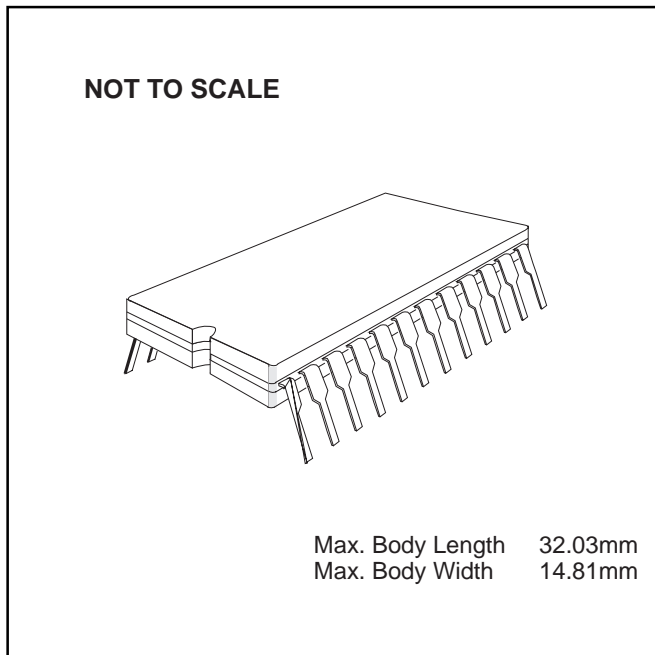

Handling Precautions

The FX806A is a CMOS LSI circuit which includes input protection. However precautions should be taken to prevent static discharges which may cause damage.

FX806A LG 24-pin quad plastic encapsulated bent and cropped (L1)

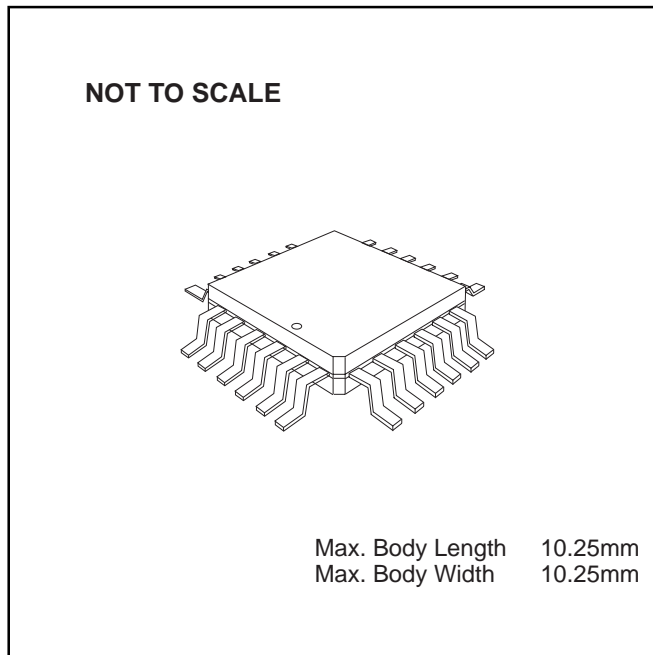

Ordering Information

FX806A J 24-pin cerdip DIL (J4)

FX806A LG 24-pin encapsulated bent and cropped (L1)

FX806A LS 24-lead plastic leaded chip carrier (L2)

FX806A LS 24-lead plastic leaded chip carrier (L2)

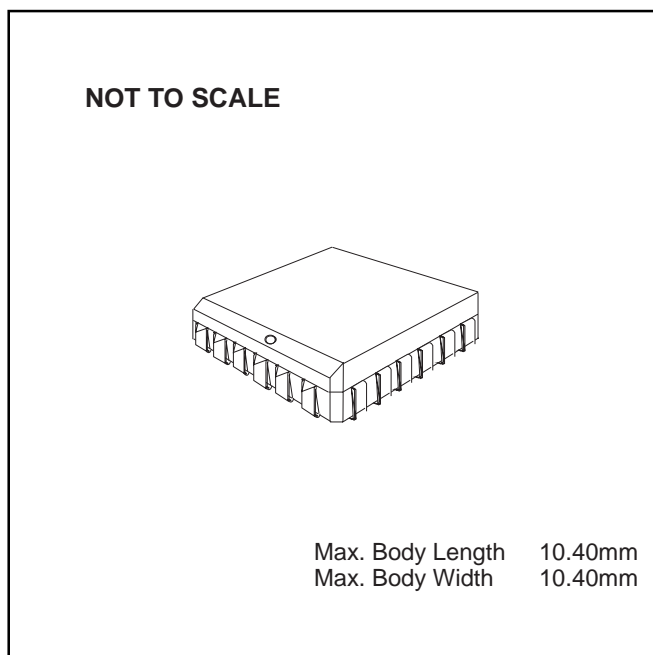



CML Microcircuits

COMMUNICATION SEMICONDUCTORS

CML Product Data

In the process of creating a more global image, the three standard product semiconductor companies of CML Microsystems Plc (*Consumer Microcircuits Limited (UK)*, *MX-COM, Inc (USA)* and *CML Microcircuits (Singapore) Pte Ltd*) have undergone name changes and, whilst maintaining their separate new names (*CML Microcircuits (UK) Ltd*, *CML Microcircuits (USA) Inc* and *CML Microcircuits (Singapore) Pte Ltd*), now operate under the single title **CML Microcircuits**.

These companies are all 100% owned operating companies of the CML Microsystems Plc Group and these changes are purely changes of name and do not change any underlying legal entities and hence will have no effect on any agreements or contacts currently in force.

CML Microcircuits Product Prefix Codes

Until the latter part of 1996, the differentiator between products manufactured and sold from MXCOM, Inc. and Consumer Microcircuits Limited were denoted by the prefixes MX and FX respectively. These products use the same silicon etc. and today still carry the same prefixes. In the latter part of 1996, both companies adopted the common prefix: CMX.

This notification is relevant product information to which it is attached.

Company contact information is as below:



**CML Microcircuits
(UK) Ltd**

COMMUNICATION SEMICONDUCTORS

Oval Park, Langford, Maldon,
Essex, CM9 6WG, England
Tel: +44 (0)1621 875500
Fax: +44 (0)1621 875600
uk.sales@cmlmicro.com
www.cmlmicro.com



**CML Microcircuits
(USA) Inc.**

COMMUNICATION SEMICONDUCTORS

4800 Bethania Station Road,
Winston-Salem, NC 27105, USA
Tel: +1 336 744 5050,
0800 638 5577
Fax: +1 336 744 5054
us.sales@cmlmicro.com
www.cmlmicro.com



**CML Microcircuits
(Singapore) Pte Ltd**

COMMUNICATION SEMICONDUCTORS

No 2 Kallang Pudding Road, 09-05/
06 Mactech Industrial Building,
Singapore 349307
Tel: +65 7450426
Fax: +65 7452917
sg.sales@cmlmicro.com
www.cmlmicro.com