



CML Semiconductor Products

PRODUCT INFORMATION

FX506 Mobile Radio Audio Processor

Publication D/506/3 July 1994

Features/Applications

- Full Rx and Tx Filtering to CEPT Standards
- Digital Control of Volume, Noise Squelch and R.S.S.I.
- Tx VOGAD Circuitry
- Serial μ P Control of ALL Chip Functions
- Deviation Limiter
- Military/Marine and Mobile Radio Applications
- FM/AM/SSB Applications
- 16-kbit Data and Voice Scrambler Compatible
- Low-Power 5-Volt CMOS Process

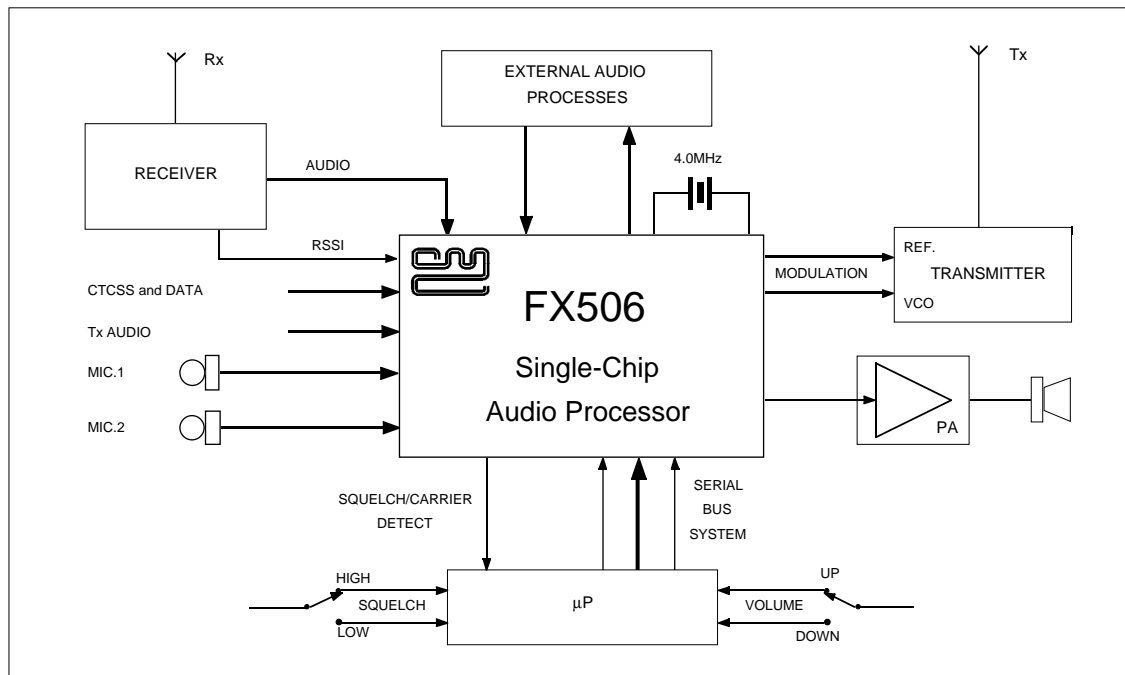

FX506

Brief Description

The FX506 is a μ Processor-controlled, single-chip device containing ALL the circuit elements necessary to perform the audio functions of a mobile (or portable) radio system.

On-chip signal paths include: speech-band/pre-emphasis filters, variable gain/attenuation stages, voice-compression and deviation limiter circuitry.

Each function in the signal path can be addressed or by-passed — *providing "real-time," dynamic control* — by the μ Processor. This half-duplex device comprises two separate audio signal paths.

The Pre-Process Path performs filtering and level adjustment on audio (Rx or Tx) for use in auxiliary systems such as "Frequency Inversion Scrambling," "Sub-Audio" tone or "In-Band" data signalling. This path is output at the "Pre-Process Audio Output" pin. If no external processes are being used this output should be connected to the "Pre-process Audio Input" pin.

The Post-Process Path can adjust and prepare the input audio for output to the chosen transmitter driver or loudspeaker amplifier.

Suitably software configured, the FX506, which can operate on voice, direct-digital or tone-data and sub-audio frequencies, is compatible with FM, AM and SSB type transceivers. Digital gain elements are provided on-chip for dynamic control and balance of signal-path levels during manufacturing, test and operation.

System Squelch, a separate path, is sourced from either the incoming signal or Received Signal Strength Indication (R.S.S.I.) from the radio circuitry.

The FX506, a low-power 5-volt CMOS device, is available in 24-pin/lead plastic DIL and SMD packages.

Pin Number Function

DIL FX506P	Quad FX506LG FX506LS	
1		Xtal: The output of the 4.0MHz on-chip clock oscillator.
2		Xtal/Clock: The input to the on-chip 4.0MHz clock oscillator inverter. All oscillator components are included on-chip. A 4.0MHz Xtal or externally derived clock should be connected here. See Figure 2.
3		V_{DD}: Positive supply rail. A single, stable +5-volt supply is required. Levels and voltages within the Audio Processor are dependent upon this supply.
4		Post Process Audio Input: The analogue input to the Post-Process Path from external audio operations. Inputs to this pin should be a.c. coupled via a capacitor C ₇ . See Figures 2 and 4.
5		Pre-Process Audio Output: The analogue output to external audio operations. See Figure 4.
6		Rx Audio Input: The input from the radio receiver demodulator. This input, which requires to be a.c. coupled via capacitor C ₆ , is selected by serial data. Audio at this input will be available for use as a signal-squelch noise source. See Figures 2 and 4.
7		V_{BIAS}: The output of the on-chip analogue bias circuitry, held internally at V _{DD} /2. This pin should be decoupled to V _{SS} via capacitor C ₁ . See Figure 2.
8		CTCSS/Data Input: To allow the introduction of sub-audio tones or data to the VCO drives. By manipulation of bits 17, 18 and 19 this input can be "mixed" into the signal path or added as a burst in between speech segments.
9		Tx Audio Input: The pre-process transmit audio input. This input can be driven from an external source or from the FX506 Mic. input circuitry. See Figures 2, 3 and 4.
10		Mic. Output: The output of the microphone multiplexer, selected by serial input data. If additional gain is required for the pre-process input, an external amplifier as shown in Figure 3 is recommended.
11		Mic.1 Input: These separate microphone audio inputs are individually selected by the serial input data. See Figures 2, 3 and 4.
12		Mic.2 Input:
13		V_{SS}: Negative supply rail (GND).

Pin Number Function

DIL FX506P	Quad FX506LG FX506LS	
14		Compression Capacitor: External components connected to this pin provide the required compression time-constant. See Figure 2.
15		Audio Output (Rx): The received audio output from the Post-Process path. This output is data selected and when powersaved is held at V_{BIAS} .
16		VCO Ref. Drive (Tx) Output: The output to drive the modulation reference oscillator. This output is data selected and when powersaved is held at V_{BIAS} . To prevent any d.c. level at this output causing incorrect frequency selection it is recommended that a.c. coupling components as shown in Figure 2 are employed. For modulation down to near d.c., these components should be by-passed.
17		VCO Drive (Tx) Output: The output to drive the modulation VCO. This output is data selected and when powersaved is held at V_{BIAS} .
18		R.S.S.I.: The input to the Squelch Selection circuitry from the radio's Received Signal Strength Indicator output. A data selected input.
19		Noise Input: The noise level can be applied to this pin. This would be the Noise Output integrated by external components, as indicated in Figure 2, or an externally produced noise level.
20		Noise Output: The output of the on-chip "squelch noise rectifier." This output is a half-wave rectified d.c. level that can be applied to the Noise Input via external integrating components. This output could also be used by an external signal detector circuit. This output level is at V_{BIAS} for no input. See Figures 2, 3 and 4.
21		Squelch Drive: A TTL compatible output. The inputs to the comparator are: the logically selected threshold level from the Digital-to-Analogue converter and the selected noise input. A logic "0" signifies that the noise threshold has been exceeded.
22		Serial Clock: The externally produced serial data loading clock input. See Figure 5. This input has an internal $1M\Omega$ pullup resistor.
23		Serial Data: The controlling, 47-bit serial data input. With $\overline{\text{Chip Select}}$ maintained at a logic "0" the serial data is entered at this pin, loaded bit 46 first, bit 0 last. Detailed information on the allocation and function of serial data bits (0 to 46) is given in tabular form on later pages. Data load timing should be carried out as described in Figure 5. This input has an internal $1M\Omega$ pullup resistor.
24		Chip Select: The data loading control function. During serial loading this input should be operated as shown in Figure 5. New data is latched on the rising edge of this waveform. This input has an internal $1M\Omega$ pullup resistor.

External Components and Interfacing

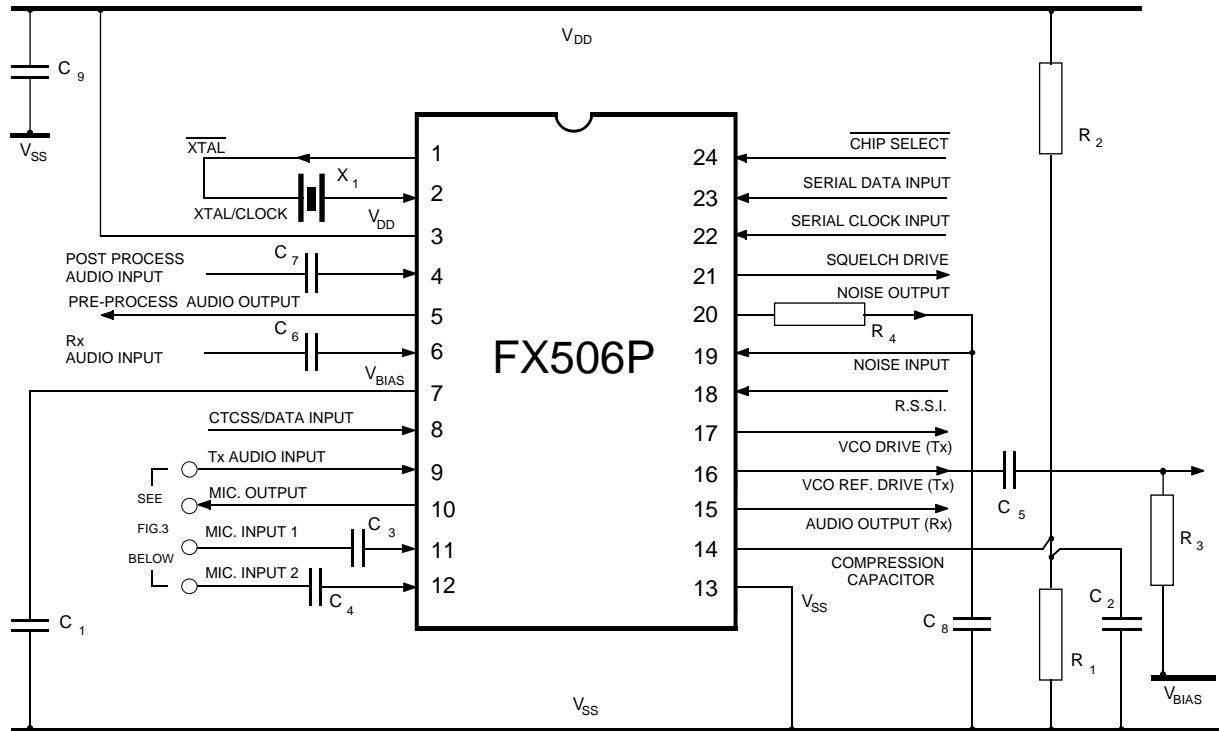

Fig.2 Recommended External Components

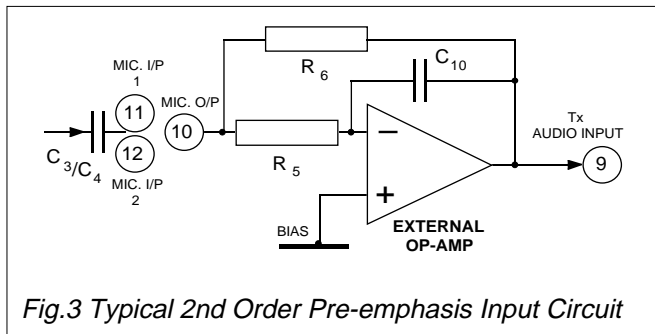

Fig.3 Typical 2nd Order Pre-emphasis Input Circuit

Notes

For dual Tx inputs using both Mic.1 and Mic.2 inputs without pre-emphasis, capacitors C₃ and C₄ will be required at the inputs as shown in Figure 2.

If pre-emphasis is required, the external circuit shown in Figure 3 is recommended.

The Op-Amp selected for this application should be of a “low noise wide-bandwidth” type i.e. with at least 60dB of gain at 6kHz.

In addition to the components shown in Figure 2, it is recommended that the power and V_{BIAS} lines to the external Op-Amp are decoupled to V_{SS} physically close to the amplifier, by a 1.0µF capacitor.

Circuit References

Component	Value	Tolerance	Component	Value	Tolerance	Component	Value	Tolerance
R ₁	100kΩ	± 10%	C ₁	1.0µF	± 20%	C ₇	0.1µF	± 20%
R ₂	390kΩ	± 10%	C ₂	6.8µF	± 20%	C ₈	0.1µF	± 20%
R ₃	100kΩ	± 1%	C ₃	1.0nF	± 1%	C ₉	1.0µF	± 20%
R ₄	10kΩ	± 10%	C ₄	1.0nF	± 1%	C ₁₀	12.0pF	± 1%
R ₅	18.0kΩ	± 1%	C ₅	15nF	± 1%			
R ₆	2.7MΩ	± 1%	C ₆	0.1µF	± 20%			
			X ₁	4.0MHz				

Layout Recommendations

Audio microcircuit performance will be affected by external noise.

All external components should be kept as close to the device as possible.

Tracks to the device should be kept short, particularly the Audio and V_{BIAS} inputs.

A “ground-plane” connected to V_{SS} will help to eliminate external pick-up.

Ensure that all inputs (analogue and d.c.) are free from noise.

Xtal/clock and digital tracks should be kept well away from analogue circuitry. Analogue inputs and outputs should be screened wherever possible with high-level outputs isolated from very low-level inputs.

PMR Audio Processor

Explanatory Block Diagram

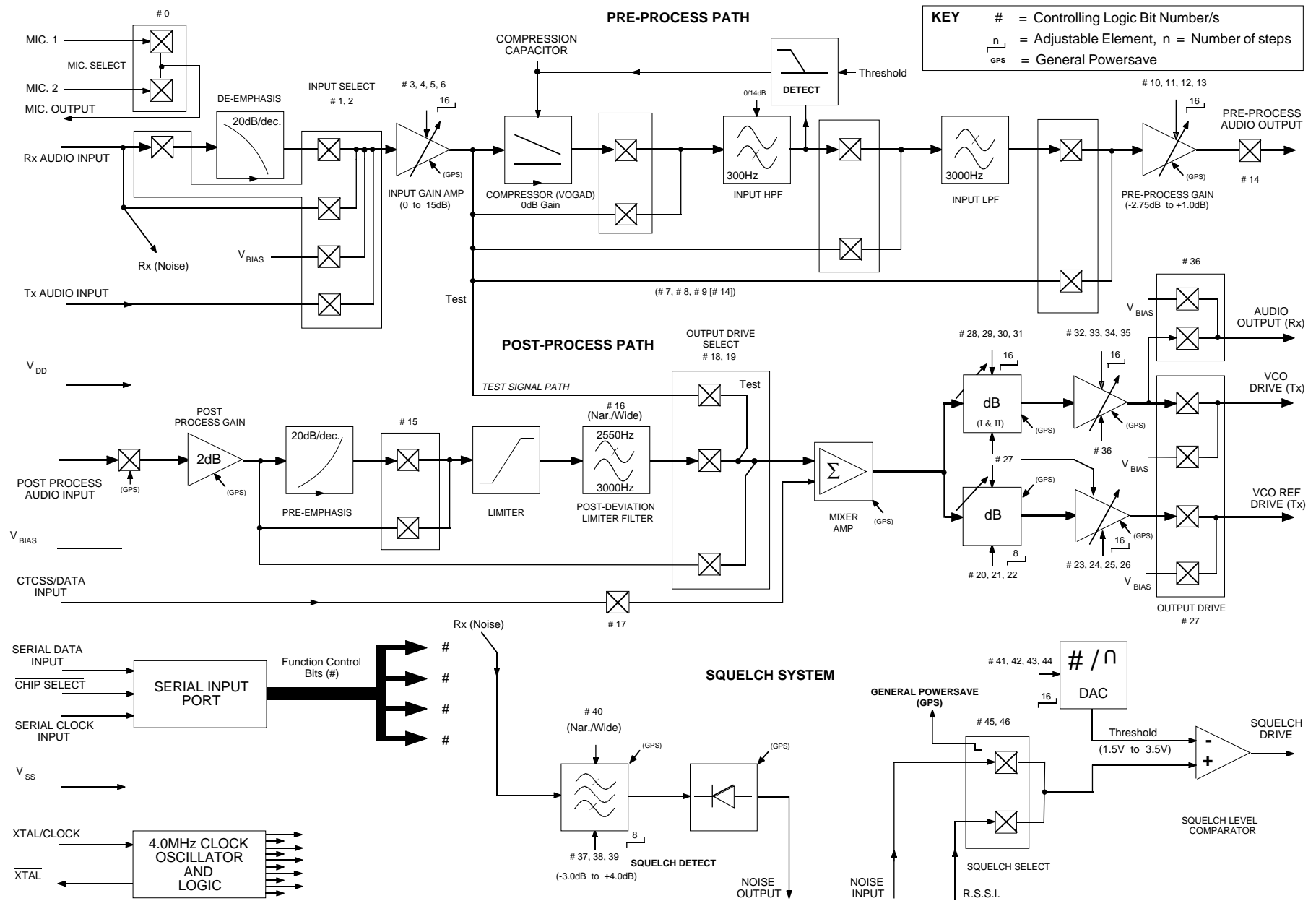

Fig.4 PMR Audio Processor – Facilities

Circuit Descriptions and Serial Control Information 1

Control bits (LSB) loaded last				Function	Notes		
0				Mic. Select	A multiplexed “microphone” input allowing the use of differing type and level voice inputs.		
0				– Microphone Input 1			
1				– Microphone Input 2			
1 2				Input Select	Transmit or receive audio sources are selected, inserting the appropriate path gain for the chosen input. The input path can be set to bias whilst allowing receiver noise monitoring.		
0 0				– Rx Input De-emphasis Bypass; HPF to 0dB			
0 1				– Rx Input De-emphasis Select; HPF to 0dB			
1 0				– Tx Input Powersave De-emphasis; HPF to 14dB			
1 1				– Path Input to V _{BIAS} ¹ Powersave De-emphasis			
3 4 5 6				Input Gain Amplifier	A gain element intended to adjust the drive level to the compressor, catering for differing signal sources and microphone sensitivities.		
0 0 0 0				– Gain Set 0.0dB			
1 0 0 0				1.0dB			
0 1 0 0				2.0dB			
1 1 0 0				3.0dB			
0 0 1 0				4.0dB			
1 0 1 0				5.0dB			
0 1 1 0				6.0dB			
1 1 1 0				7.0dB			
0 0 0 1				8.0dB			
1 0 0 1				9.0dB			
0 1 0 1				10.0dB			
1 1 0 1				11.0dB			
0 0 1 1				12.0dB			
1 0 1 1				13.0dB			
0 1 1 1				14.0dB			
1 1 1 1				15.0dB			
7 8 9 14							
1 1 1 1				Compressor Enabled	HPF Enabled	LPF Enabled	Pre-Process Output Enabled
0 1 1 1				Powersaved	Enabled	Enabled	Enabled
X 0 1 1				Powersaved	Powersaved	Enabled	Enabled
X X 0 1				Powersaved	Powersaved	Powersaved	Enabled
X X X 0				Powersaved	Powersaved	Powersaved	Powersaved
10 11 12 13				Pre-Process Gain	An in-line output drive stage providing adjustable gain or attenuation to compensate for level tolerances in the external audio processes and peripherals. The output of this amplifier stage is available for further voice (audio) processing such as “Frequency Inversion Voice Scrambling.”		
0 0 0 0				– Gain Set -2.75dB			
1 0 0 0				-2.50dB			
0 1 0 0				-2.25dB			
1 1 0 0				-2.00dB			
0 0 1 0				-1.75dB			
1 0 1 0				-1.50dB			
0 1 1 0				-1.25dB			
1 1 1 0				-1.00dB			
0 0 0 1				-0.75dB			
1 0 0 1				-0.50dB			
0 1 0 1				-0.25dB			
1 1 0 1				0dB			
0 0 1 1				0.25dB			
1 0 1 1				0.50dB			
0 1 1 1				0.75dB			
1 1 1 1				1.00dB			
14				Pre-Process Output	Bit 14 is the Enable/Powersave function for the Pre-Process output stages. See Bits 7 8 9 14 <i>Reference Figure 4</i>		
0				– Disable Pre-Process Output Output at V _{BIAS}			
1				– Enable Pre-Process Audio Output			

Circuit Descriptions and Serial Control Information 2

Control bits				Element	Notes	
15				Post-Process Gain	A fixed 2.0dB gain stage.	
				Pre-emphasis	A selectable pre-emphasis stage set around 1.0kHz, with a characteristic of 6dB per octave. It is available for use when transmitting data signals such as FFSK. See Table below for Powersave information.	
				Deviation Limiter and	A pre-set amplitude limiting stage for deviation control.	
16 0 1				Post-Deviation Limiter Filter	This lowpass filter which is selected with the Deviation Limiter, is adjustable to Narrow (2550Hz) and Wide (3000Hz) bandwidths, allowing for different channel-spacing requirements.	
				– Narrow filter bandwidth, cut-off = 2550Hz. – Wide filter bandwidth, cut-off = 3000Hz.		
17 0 1				CTCSS/Data Input	– Disable Input path to Mixer system – Enable Input path to Mixer system	
15	18	19		Pre-Emphasis	Limiter and Post-Dev LPF	Drive Selected
X	0	0		Powersaved	Powersaved	Test Path
0	1	0		Powersaved	Enabled	Post-Process Path
1	1	0		Enabled	Enabled	Post-Process Path
X	1	1		Powersaved	Powersaved	Post-Process Bypass
X	0	1		Powersaved	Powersaved	Bias
20 21 22 0 0 0 1 0 0 0 1 0 1 1 0 0 0 1 1 0 1 0 1 1 1 1 1				VCO Reference Drive Attenuator	The in-line control attenuator for the VCO reference channel drive output.	
				– Gain Set		-28dB
						-24dB
						-20dB
						-16dB
						-12dB
						-8.0dB
						-4.0dB
	0.0dB					
23 24 25 26 0 0 0 0 1 0 0 0 0 1 0 0 1 1 0 0 0 0 1 0 1 0 1 0 0 1 1 0 1 1 1 0 0 0 0 1 1 0 0 1 0 1 0 1 1 1 0 1 0 0 1 1 1 0 1 1 0 1 1 1 1 1 1 1				VCO Reference Drive Amplifier	The in-line control amplifier/attenuator for the VCO reference channel drive output.	
				– Gain Set		-2.75dB
						-2.50dB
						-2.25dB
						-2.00dB
						-1.75dB
						-1.50dB
						-1.25dB
						-1.00dB
						-0.75dB
						-0.50dB
						-0.25dB
						0dB
	0.25dB					
	0.50dB					
	0.75dB					
	1.00dB					
27				Output Drive Control	Used in conjunction with Bit 36 to control output functions.	

Reference Figure 4

Circuit Descriptions and Serial Control Information 3

Control bits				Element	Notes															
28	29	30		VCO Drive Attenuator I – Gain Set -22.4dB -19.2dB -16.0dB -12.8dB -9.6dB -6.4dB -3.2dB 0dB	An in-line control attenuator for the VCO Tx channel drive output. This channel is also selected as Audio Output (Rx) under the control of bit 36. This attenuator can be used in a volume control application.															
0	0	0																		
1	0	0																		
0	1	0																		
1	1	0																		
0	0	1																		
1	0	1																		
0	1	1																		
1	1	1																		
	31					VCO Drive Attenuator II – Gain Set -25.6dB 0dB	An in-line control attenuator for the VCO Tx channel drive output. As an example, when bits 28 to 31 are set to “0,” the gain set is -48.0dB (-22.4 + -25.6).													
	0																			
	1																			
32	33	34	35	VCO Drive Amplifier – Gain Set -2.75dB -2.50dB -2.25dB -2.00dB -1.75dB -1.50dB -1.25dB -1.00dB -0.75dB -0.50dB -0.25dB 0dB 0.25dB 0.50dB 0.75dB 1.00dB	The in-line control amplifier/attenuator for the VCO Tx channel drive output. This channel is also selected as Audio Output (Rx) under the control of bit 36. This amplifier can be used in a volume control application.															
0	0	0	0																	
1	0	0	0																	
0	1	0	0																	
1	1	0	0																	
0	0	1	0																	
1	0	1	0																	
0	1	1	0																	
1	1	1	0																	
0	0	0	1																	
1	0	0	1																	
0	1	0	1																	
1	1	0	1																	
0	0	1	1																	
1	0	1	1																	
0	1	1	1																	
1	1	1	1																	
	27	36	<table border="1"> <thead> <tr> <th><i>VCO Drive (Tx) Output</i></th> <th><i>VCO Ref (Tx) Output</i></th> <th><i>Audio Output (Rx)</i></th> </tr> </thead> <tbody> <tr> <td>Bias</td> <td>Bias</td> <td>Bias</td> </tr> <tr> <td>Bias</td> <td>Bias</td> <td>Enabled</td> </tr> <tr> <td>Enabled</td> <td>Enabled</td> <td>Bias</td> </tr> <tr> <td>Enabled</td> <td>Enabled</td> <td>Enabled</td> </tr> </tbody> </table> <p>The Drive and Ref. paths are powersaved by Bits 45 and 46 in the “Total Powersave” or “Listening Powersave” conditions. When making internal changes it is recommended that these outputs are disconnected (<i>placed in a bias condition</i>) from the relevant output (load) circuitry.</p>			<i>VCO Drive (Tx) Output</i>	<i>VCO Ref (Tx) Output</i>	<i>Audio Output (Rx)</i>	Bias	Bias	Bias	Bias	Bias	Enabled	Enabled	Enabled	Bias	Enabled	Enabled	Enabled
<i>VCO Drive (Tx) Output</i>	<i>VCO Ref (Tx) Output</i>	<i>Audio Output (Rx)</i>																		
Bias	Bias	Bias																		
Bias	Bias	Enabled																		
Enabled	Enabled	Bias																		
Enabled	Enabled	Enabled																		
	0	0																		
	0	1																		
	1	0																		
	1	1																		
37	38	39		Squelch Filter (Gain) – Gain Set -3.0dB -2.0dB -1.0dB 0dB 1.0dB 2.0dB 3.0dB 4.0dB	The squelch function is set by bits 45 & 46 (Squelch Source Selection). The centre frequency gain of this element is 35dB, data selected gain variations (-3.0dB to 4.0dB) are around this value.															
0	0	0																		
1	0	0																		
0	1	0																		
1	1	0																		
0	0	1																		
1	0	1																		
0	1	1																		
1	1	1																		
	40			Squelch Filter (Narrow/Wide) – Narrow ($f_c \approx 18\text{kHz} \pm 6.5\text{kHz}$). – Wide ($f_c \approx 25\text{kHz} \pm 8.5\text{kHz}$).	For use in wide or narrow channel systems. The squelch function is set by bits 45 & 46 (Squelch Source Selection).															
	0																			
	1																			

Reference Figure 4

Circuit Descriptions and Serial Control Information 4

Control bits				Element	Notes
41	42	43	44	Squelch Threshold Voltage	The fine squelch adjustment level from the Digital-to-Analogue converter.
0	0	0	0	3.500V d.c. 70.0% V_{DD}	
1	0	0	0	3.366 67.3%	These threshold levels are used as a comparison with the selected input noise voltage (bits 45 and 46).
0	1	0	0	3.233 64.6%	
1	1	0	0	3.100 62.0%	
0	0	1	0	2.966 59.3%	Variation in V_{DD} will produce variation in threshold levels.
1	0	1	0	2.833 56.6%	
0	1	1	0	2.700 54.0%	
1	1	1	0	2.566 51.3%	
0	0	0	1	2.433 48.6%	
1	0	0	1	2.300 46.0%	
0	1	0	1	2.166 43.3%	
1	1	0	1	2.033 40.6%	
0	0	1	1	1.900 38.0%	
1	0	1	1	1.766 35.3%	
0	1	1	1	1.633 32.6%	
1	1	1	1	1.500 30.0%	
	45	46		Squelch Source Selector	As well as selecting the input to the Noise Comparator, these two bits produce additional General Powersave (GPS) functions which control those elements not having individual serial control.
	0	0		A "Total Powersave" condition	Powersaved: Input Gain Amp – Post Process (2dB) Gain Amp – Mixer Amp – Noise BPF – Noise Rectifier – Squelch Comparator
	1	0		Noise Input selected to Comparator	
	0	1		R.S.S.I. input selected to Comparator	
	1	1		Powersave but LISTENING condition R.S.S.I. input selected to Comparator	Powersaved: Input Gain Amp – Post Process (2dB) Gain Amp – Mixer Amp – Noise BPF – Noise Rectifier
Rx Noise Path				Any high-frequency noise (18kHz/25kHz) present at the Rx Audio Input will also be available at the Noise Output pin via the squelch filter and noise rectifier (when enabled) for use as a squelch detection level. This means that the FX506 can be set to "LISTEN" with the majority of circuit elements powersaved until an R.S.S.I. level is detected and produces a "Squelch Drive output."	
Test Signal Path				This path, when selected, can be used as a direct path, via the Output Drive Selector (bits 18 and 19), to dynamically set and balance the VCO drive and reference output levels.	

Reference Figure 4

Serial Control Bits – Loading and Timing Information

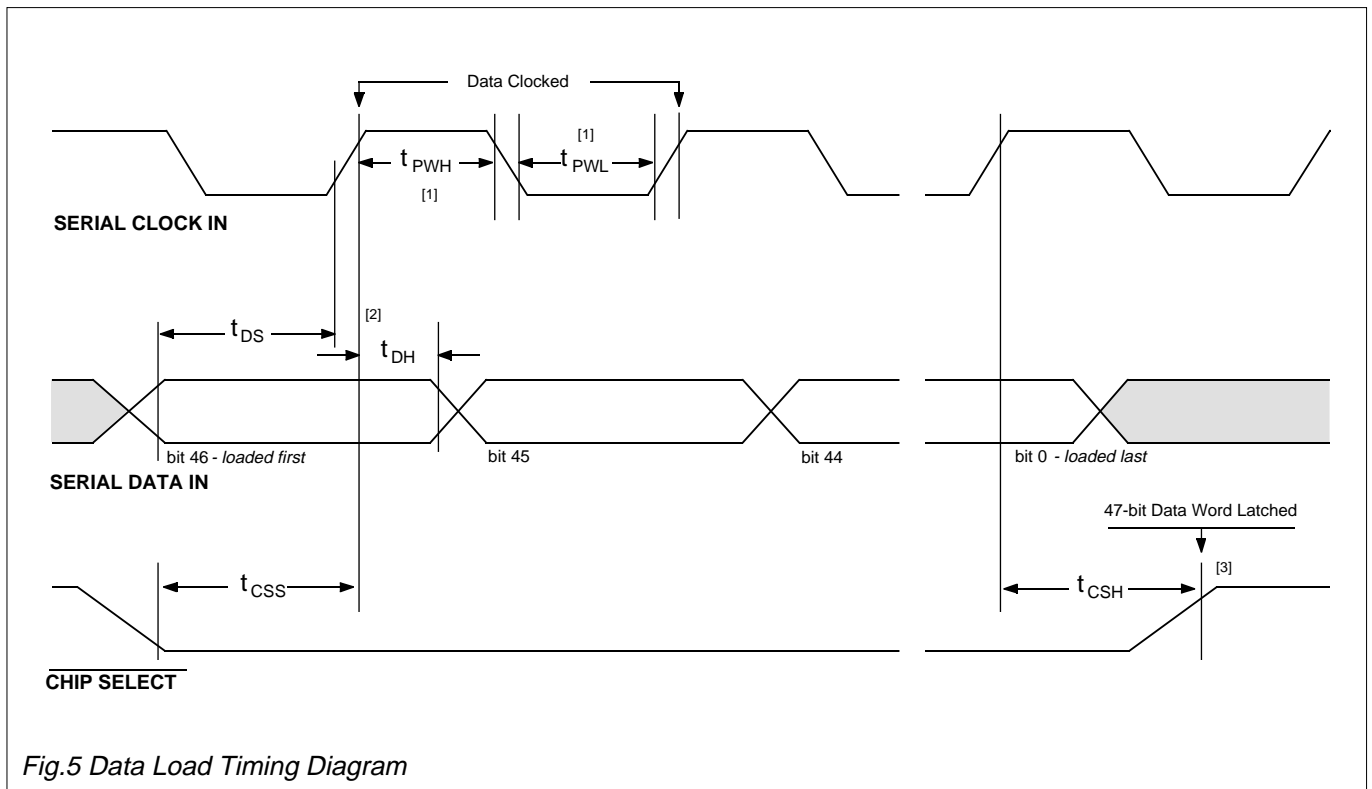

Fig.5 Data Load Timing Diagram

Data Loading

Serial Data bits, whose functions are described on the previous pages, are loaded to the FX506 using the timing format illustrated on this page. All 47 bits must be loaded. Data is loaded bit 46 first, bit 0 last.

Function		Min.	Typ.	Max.	Unit
Serial Clock	[1]				
'High' Pulse Width	t_{PWH}	600	—	—	ns
'Low' Pulse Width	t_{PWL}	600	—	—	ns
Serial Data	[2]				
Data Set-Up Time	t_{DS}	360	—	—	ns
Data Hold Time	t_{DH}	120	—	—	ns
Chip Select	[3]				
Select Set-Up Time	t_{CSS}	600	—	—	ns
Select Hold Time	t_{CSH}	600	—	—	ns

[1] The Serial Clock pulses do not have to be symmetrical, as shown above, but pulse lengths must conform to the "minimum" time specification.

[2] Individual data bits (logic "1" or "0") are loaded to the device on the rising edge of the input Serial Data Clock pulse. The data hold period (t_{DH}) is to ensure that the data level is steady when it is sampled.

[3] The full 47-bit data word is latched into the device on the rising edge of the Chip Select waveform, at this time the loaded data is acted upon and the circuit configuration/settings will change.

System Response Characteristics

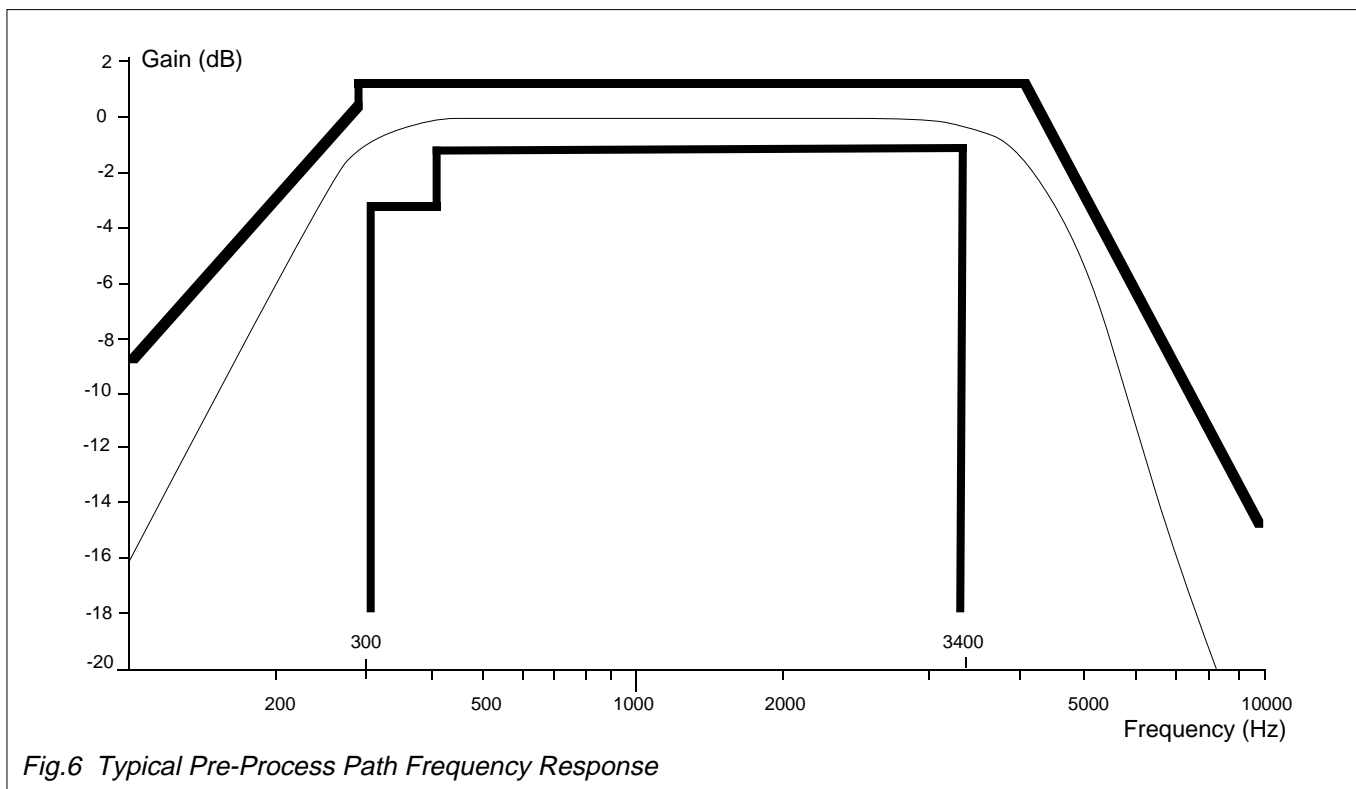

System Frequency Characteristics

Figure 6 shows a typical, response curve of the Pre-Process Path, in receive mode, set against the device specification. The general characteristic shape is produced by the Input Highpass and Lowpass Filters, without the internal pre-emphasis element.

Figure 7 shows a typical response curve of the Post-Process Path set against the device specification. The general characteristic shape is produced by the Post-Deviation Limiter Filter, without the de-emphasis element.

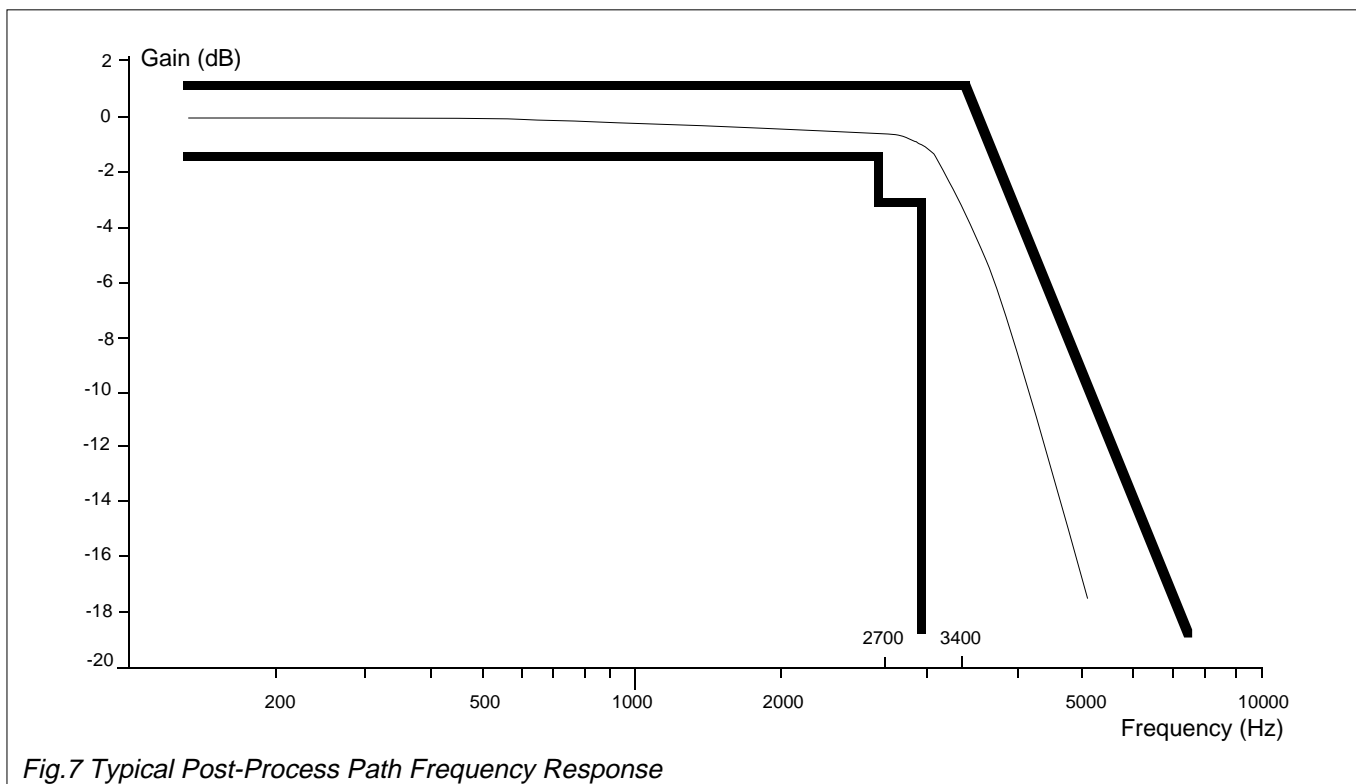

Application Information

Suggested Evaluation Tests and Settings

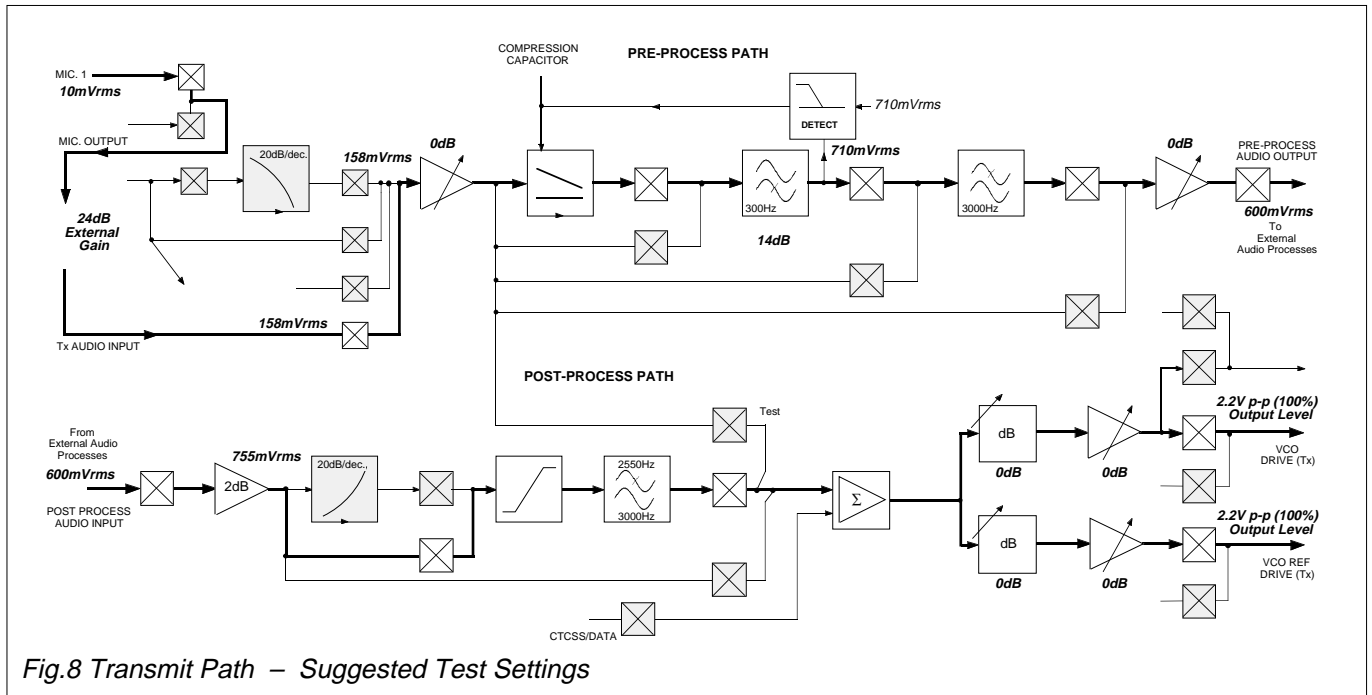

Active elements used in the signal path.
 Powersaved or by-passed elements that are not employed in the signal path.

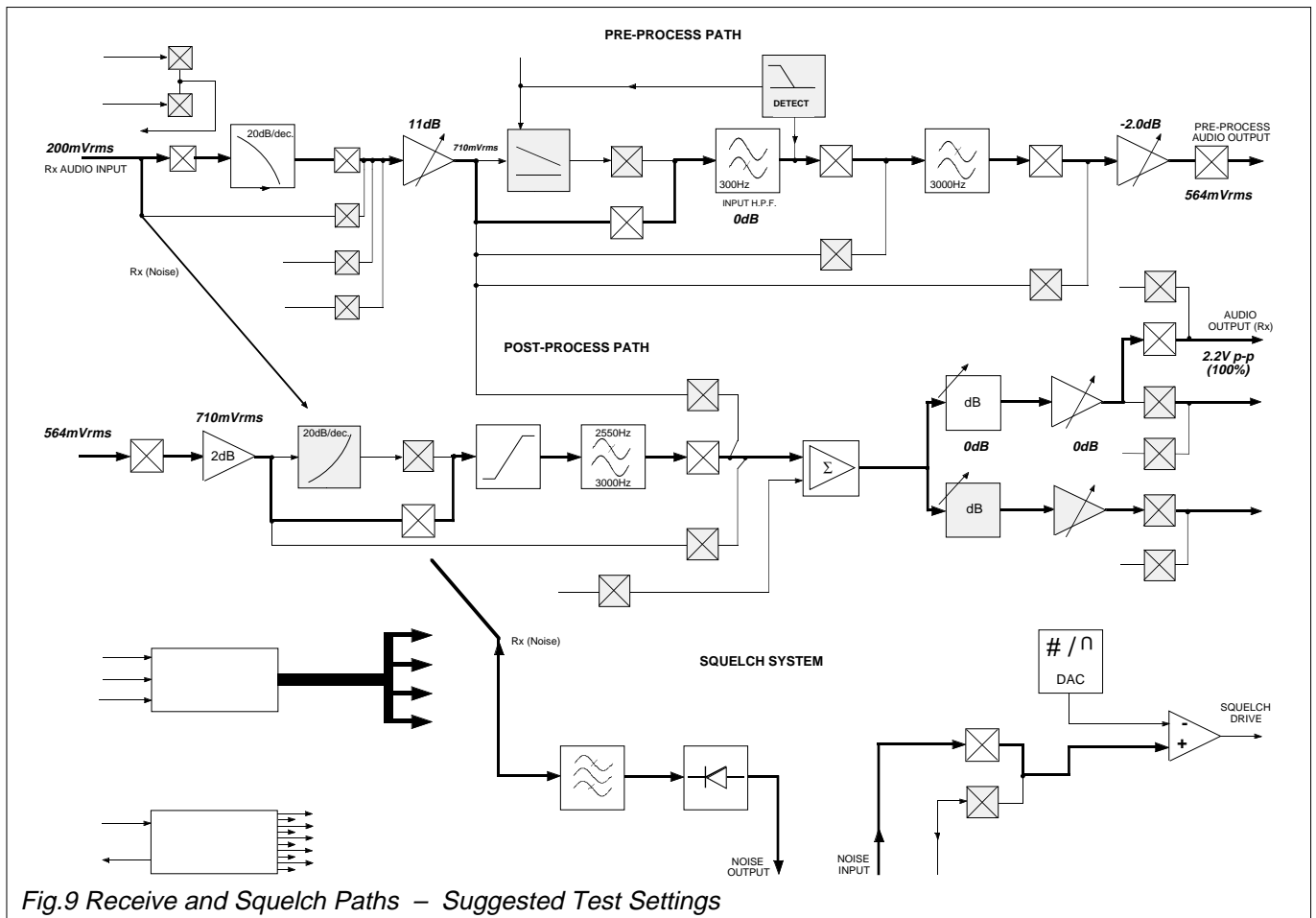

Application Information

Suggested Evaluation Tests and Settings

Operational Information

The functions of the FX506 are selected and controlled using the 47-bit Serial Data Input. This application section assists in the familiarization of control by providing example operational paths and system confidence tests.

The signal levels employed in these examples are to demonstrate the functions of the device. Maximum and minimum operational signal levels are detailed in the "Specification" pages. A final output signal level of 2.2V p-p is considered, operationally, to be 100% (FM deviation).

Set-up and enter the example data word in accordance with Figures 2 and 4.
Test the FX506 using levels and points detailed in Tables 1, 2 and 3.

Experimentation will indicate the signal element configuration and required control settings for various input and output levels.

Transmit Path – The Serial Data word below will produce the transmit element configuration shown in Figure 8.						
bit 0 – 01000001 11110110 X0101111 10111111 11010XXX XXXXX10 – bit 46						
0 = logic 0		1 = logic 1		X = not important to the example		
Step	Input	Level (mV rms @ 1kHz)	Output	Level (mV rms @ 1kHz)	Note	Output Level Ref. to Max.
1	Mic. 1	10	Pre-Process Audio	750	Ext +24.0dB	
2	Ext. Audio Process In	750	VCO Drive/Ref.	$1.54 \leq V_{OUT} \leq 2.2V_{p-p}$		70 – 100%
3	Mic. 1	4.8	Pre-Process Audio	410	Ext +24.0dB	60%
4	Ext. Audio Process In	410	VCO Drive and Ref.	466		60%

Table 1 Transmit Path Operational Check

To establish a 100% level for this device inject a large amplitude audio signal into the Post Process Audio Input, with the Limiter enabled.

Receive Path – The Serial Data word below will produce the receive element configuration shown in Figure 9.						
bit 0 – X0111010 11110010 X010XXXX XXX01111 11011XXX XXXXX10 – bit 46						
0 = logic 0		1 = logic 1		X = not important to the example		
Step	Input	Level (mV rms @ 1kHz)	Output	Level (mV rms @ 1kHz)	Note	Output Level Ref. to Max.
1	Rx Audio In	200	Pre-Process Audio	564		
2	Ext. Audio Process In	564	Audio Out (Rx)	$1.54 \leq V_{OUT} \leq 2.2V_{p-p}$		70 -100%
3	Rx Audio In	145	Audio Out (Rx)	466		60%
4	Rx Audio In	145	Audio Out (Rx)	$466 \pm$	vary bits 28 – 35 for Volume	$60\% \pm$

Table 2 Receive Path Operational Check

To establish a 100% level for this device inject a large amplitude audio signal into the Post Process Audio Input, with the Limiter enabled.

Squelch Path – The Serial Data word below will produce the squelch element configuration shown in Figure 9.						
bit 0 – X00XXXXX XXXXXX0X X010XXXX XXX0XXXX XXXX1110 1110110 – bit 46						
0 = logic 0		1 = logic 1		X = not important to the example		
Step	Input	Level (mV rms @ 25kHz)	Output	Level	Note	
1	Rx Audio In	0	Squelch Drive	logic "1"	No noise – "Noise Out" = V_{BIAS}	
2	Rx Audio In	50.0	Squelch Drive	logic "0"	Noise In – "Noise Out" decreases	

Table 3 Squelch Path Operational Check

Specification

Absolute Maximum Ratings

Exceeding the maximum rating can result in device damage. Operation of the device outside the operating limits is not implied.

Supply voltage		-0.3 to 7.0V
Input voltage at any pin (ref $V_{SS} = 0V$)		-0.3 to ($V_{DD} + 0.3V$)
Sink/source current (supply pins)		+/- 30mA
(other pins)		+/- 20mA
Total device dissipation @ $T_{AMB} = 25^{\circ}C$		800mW Max.
Derating		10mW/ $^{\circ}C$
Operating temperature range:	FX506P	-30 $^{\circ}C$ to +70 $^{\circ}C$ (plastic)
	FX506LG/LS	-30 $^{\circ}C$ to +70 $^{\circ}C$ (plastic)
Storage temperature range:	FX506P	-40 $^{\circ}C$ to +85 $^{\circ}C$ (plastic)
	FX506LG/LS	-40 $^{\circ}C$ to +85 $^{\circ}C$ (plastic)

Operating Limits

All device characteristics are measured under the following conditions unless otherwise specified:

$V_{DD} = 5.0V$. $T_{AMB} = 25^{\circ}C$. Xtal/Clock $f_0 = 4.0MHz$. Audio level 0dB ref: = 466mV rms @ 1.0kHz (60% deviation, FM).

Characteristics	See Note	Min.	Typ.	Max.	Unit
Static Values					
Supply Voltage		4.5	5.0	5.5	V
Supply Current	(All Elements Enabled)	–	8.0	–	mA
	(Listening Powersave)	–	–	1.0	mA
	(Maximum Powersave)	–	–	1.0	mA
Dynamic Values					
Input Logic “1”	1	3.5	–	–	V
Input Logic “0”	1	–	–	1.5	V
Input Impedances					
Digital		0.1	1.0	–	M Ω
Mic.1 or 2		–	0.5	–	k Ω
Rx Audio		30.0	–	–	k Ω
Tx Audio		30.0	56.0	–	k Ω
CTCSS/Data		50.0	100	–	k Ω
External Audio Process		1.0	–	–	M Ω
Noise, R.S.S.I.		1.0	–	–	M Ω
Output Impedances					
Pre-Process Audio		–	–	3.0	k Ω
Audio Out (Rx)		–	–	3.0	k Ω
VCO Drive and Ref. Out		–	–	3.0	k Ω
Squelch Drive	(Logic “1”)	–	5.0	–	k Ω
	(Logic “0”)	–	500	–	Ω
Noise Output	(Diode conducting)	–	1.0	–	k Ω
	(Diode not conducting)	–	500	–	k Ω
Signal Path Switch Isolation (Disabled)					
Switches		40.0	–	–	dB
Test Path		–	60.0	–	dB
Signal Input Levels					
	10				
Mic.1 or 2		1.0	–	100	mV rms
Rx Audio		–	145	200	mV rms
Tx Audio		–	–	1414	mV rms
CTCSS/Data		–	–	4.0	V p-p
Post Process		–	–	1123	mV rms
Noise, R.S.S.I.	2	–	–	4.0	V p-p
Signal Output Levels					
	10				
Pre-Process Audio	(Compressor enabled)	–	600	–	mV rms
VCO – (Drive, Ref.)	(Limiter in circuit)	–	2.2	–	V p-p
Audio (Rx)	(Limiter in circuit)	–	2.2	–	V p-p
Variable Element Step					
Input Gain Amp		0.7		1.3	dB
Pre-Process Gain		0.2		0.3	dB
VCO Ref. Attenuator		3.5		4.5	dB
VCO Drive Attenuator I		2.7		3.7	dB
VCO Drive Attenuator II		25.0		26.2	dB
VCO Amplifiers (Drive and Ref.)		0.2		0.3	dB

Specification

Characteristics	See Note	Min.	Typ.	Max.	Unit
Output Distortion					
Output Signal-to-Noise Ratio	3, 12	48.0	52.0	–	dBp
Total Harmonic Distortion Level	4, 11	–	-40.0	-30.0	dB
Compressor					
Dynamic Range		–	30.0	–	dB
Attack Time		–	7.0	–	ms
Decay Time		–	1000	–	ms
Deviation Limiter					
Input Thresholds	4	–	2.0	–	V p-p
Frequency Responses					
Pre-Process Path					
Passband Frequencies	6				
-3dB (Lower)		–	240	–	Hz
-3dB (Upper)		–	4.7	–	kHz
Passband Ripple	(300Hz - 400Hz)	5	-3.0	–	dB
	(400Hz - 3400Hz)	5	-1.5	–	dB
Stopband Attenuation	($f = 5\text{kHz}$)		3.0	–	dB
High Frequency Roll-off	($f = >5\text{kHz}, <20\text{kHz}$)		12.0	–	dB/oct.
Stopband Attenuation	($f = 250\text{Hz}$)		–	2.3	dB
Low Frequency Roll-off	($f = <250\text{Hz}$)		6.0	–	dB/oct.
Post-Process Path					
Wideband : Lowpass Frequency (-3dB)	7	–	3.4	–	kHz
Passband Ripple	(< 2700Hz)	8	-1.5	–	dB
	(2700Hz - 3000Hz)	8	-3.0	–	dB
Stopband Attenuation	($f = 5\text{kHz}$)		12.2	–	dB
High Frequency Roll-off	($f = >3\text{kHz}, <20\text{kHz}$)		18.0	–	dB/oct.
Narrowband: Lowpass Frequency (-3dB)		–	2.9	–	kHz
Passband Ripple	(< 2300Hz)		-1.5	–	dB
	(2300Hz - 2550Hz)		-3.0	–	dB
Stopband Attenuation	($f = 4.25\text{kHz}$)		12.2	–	dB
High Frequency Roll-off	($f = >2.3\text{kHz}, <5.1\text{kHz}$)		18.0	–	dB/oct.
Pre-emphasis: Passband Frequencies		300		3000	Hz
Gain at 1kHz		–	0	–	dB
Slope Characteristic		–	6.0	–	dB/oct.
De-emphasis: Passband Frequencies		300		3000	Hz
Gain at 1kHz		–	0	–	dB
Slope Characteristic		–	6.0	–	dB/oct.
Squelch Bandpass Filter					
Centre Frequency Gain	(Wide and Narrow)		–	35.0	dB
Selectable Gain	(8 x 1.0dB steps)	9	-3.0	–	dB
Narrow Band:					
Centre Frequency	(f_c)		–	18.75	kHz
Bandwidth	($f_c \pm$)		–	6.5	kHz
Wideband:					
Centre Frequency	(f_c)		–	25.5	kHz
Bandwidth	($f_c \pm$)		–	8.5	kHz

Notes

1. A percentage of the applied V_{DD} (70% or 30%).
2. These inputs are compared internally with the Digital-to-Analogue converter.
3. With a minimum signal input level of 50mVrms at the Tx I/P or 65mVrms at the Rx I/P and an output level of 466mVrms.
4. Levels at the input of the Limiter element, centred about V_{BIAS} (Note 2).
5. This parameter remains within specification when pre-emphasis is employed.
6. With both Input HPF and LPF in circuit, but without pre-emphasis.
7. With Limiter LPF, but without de-emphasis characteristics.
8. This parameter remains within specification when de-emphasis is employed.
9. The gain variation around the centre frequency (f_c).
10. See Application Information pages (Suggested Evaluation Tests) for information on gain element settings.
11. Mode: Tx with Compressor "OFF;" or in Rx, signal below limiter thresholds; Output level 466mVrms. Measured in a 30kHz bandwidth.
12. In the Tx mode with the Input Gain Amp set to $\leq 4.0\text{dB}$.

Package Outlines

The FX506 is available in the package styles outlined below. Mechanical package diagrams and specifications are detailed in Section 10 of this document.

Pin 1 identification marking is shown on the relevant diagram and pins on all package styles number anti-clockwise when viewed from the top.

FX506LG 24-pin quad plastic encapsulated bent and cropped (L1)

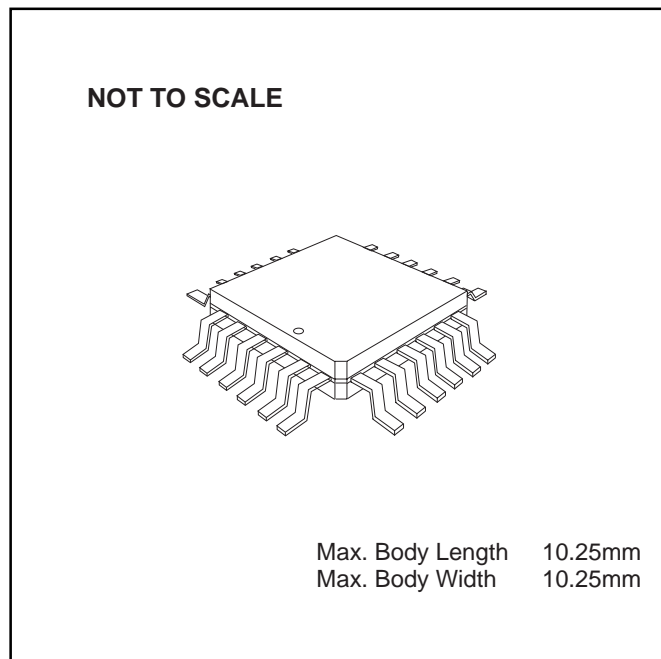

Handling Precautions

The FX506 is a CMOS LSI circuit which includes input protection. However precautions should be taken to prevent static discharges which may cause damage.

FX506LS 24-lead plastic leaded chip carrier (L2)

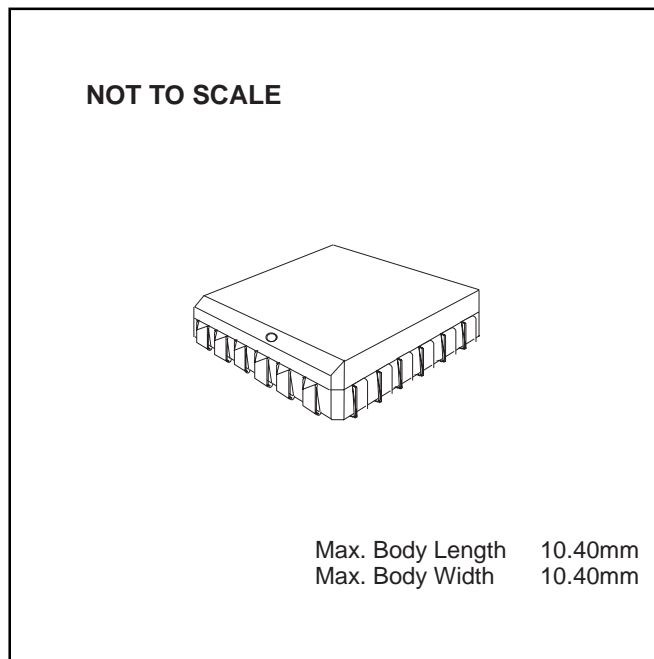

Ordering Information

FX506LG 24-pin encapsulated bent and cropped (L1)

FX506LS 24-lead plastic leaded chip carrier (L2)

FX506P 24-pin plastic DIL (P4)

FX506P 24-pin plastic DIL (P4)

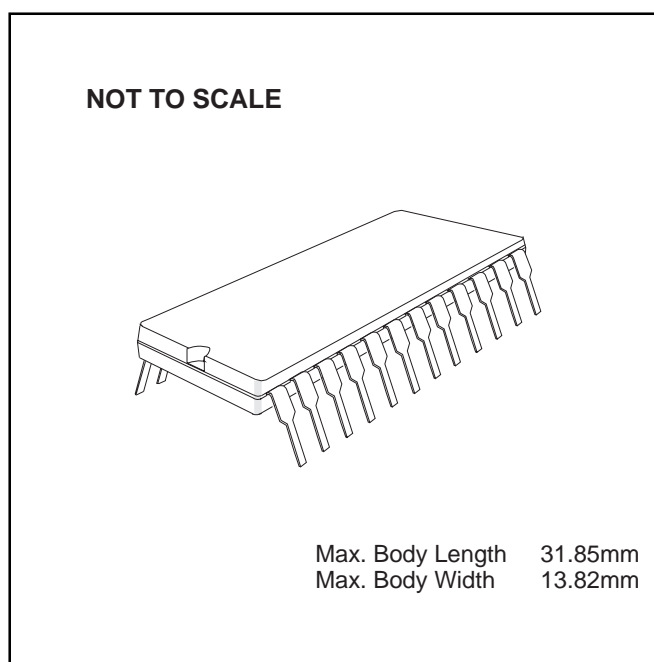



CML Microcircuits

COMMUNICATION SEMICONDUCTORS

CML Product Data

In the process of creating a more global image, the three standard product semiconductor companies of CML Microsystems Plc (*Consumer Microcircuits Limited (UK)*, *MX-COM, Inc (USA)* and *CML Microcircuits (Singapore) Pte Ltd*) have undergone name changes and, whilst maintaining their separate new names (*CML Microcircuits (UK) Ltd*, *CML Microcircuits (USA) Inc* and *CML Microcircuits (Singapore) Pte Ltd*), now operate under the single title **CML Microcircuits**.

These companies are all 100% owned operating companies of the CML Microsystems Plc Group and these changes are purely changes of name and do not change any underlying legal entities and hence will have no effect on any agreements or contacts currently in force.

CML Microcircuits Product Prefix Codes

Until the latter part of 1996, the differentiator between products manufactured and sold from MXCOM, Inc. and Consumer Microcircuits Limited were denoted by the prefixes MX and FX respectively. These products use the same silicon etc. and today still carry the same prefixes. In the latter part of 1996, both companies adopted the common prefix: CMX.

This notification is relevant product information to which it is attached.

Company contact information is as below:



**CML Microcircuits
(UK) Ltd**

COMMUNICATION SEMICONDUCTORS

Oval Park, Langford, Maldon,
Essex, CM9 6WG, England
Tel: +44 (0)1621 875500
Fax: +44 (0)1621 875600
uk.sales@cmlmicro.com
www.cmlmicro.com



**CML Microcircuits
(USA) Inc.**

COMMUNICATION SEMICONDUCTORS

4800 Bethania Station Road,
Winston-Salem, NC 27105, USA
Tel: +1 336 744 5050,
0800 638 5577
Fax: +1 336 744 5054
us.sales@cmlmicro.com
www.cmlmicro.com



**CML Microcircuits
(Singapore) Pte Ltd**

COMMUNICATION SEMICONDUCTORS

No 2 Kallang Pudding Road, 09-05/
06 Mactech Industrial Building,
Singapore 349307
Tel: +65 7450426
Fax: +65 7452917
sg.sales@cmlmicro.com
www.cmlmicro.com