

Features

- Epitaxial Planar Die Construction
- Complementary PNP Type Available (DDTA144ELP)
- Ultra-Small Leadless Surface Mount Package
- Ideally Suited for Automated Assembly Processes
- **Lead Free By Design/RoHS Compliant (Note 1)**
- **"Green" Device (Note 2)**
- **Qualified to AEC-Q101 Standards for High Reliability**

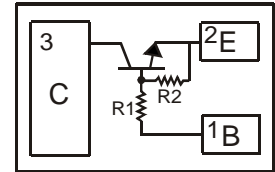
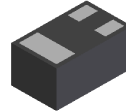

Mechanical Data

- Case: DFN1006-3
- Case Material: Molded Plastic, "Green" Molding Compound. UL Flammability Classification Rating 94V-0
- Moisture Sensitivity: Level 1 per J-STD-020C
- Terminal Connections: Collector Dot - See Marking Information
- Terminals: Finish — NiPdAu over Copper leadframe. Solderable per MIL-STD-202, Method 208
- Marking Code N6, Dot denotes Collector Side
- Ordering Information: See Page 3
- Weight: 0.001 grams (approximate)

DFN1006-3

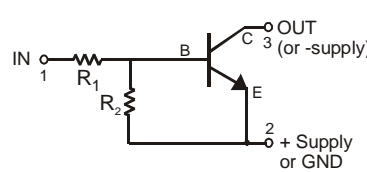

Schematic and Pin Configuration

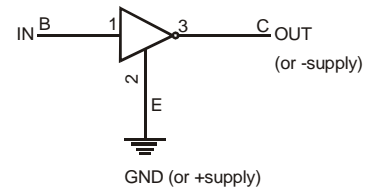

Equivalent Inverter Circuit

Component P/N	R1(NOM)	R2(NOM)
DDTC144ELP	47K	47K

Maximum Ratings @T_A = 25°C unless otherwise specified

Characteristic	Symbol	Value	Unit
Supply Voltage	V _{CC}	50	V
Input Voltage	V _{IN}	-10 to +40	V
Output Current	I _{C(max)}	100	mA

Thermal Characteristics

Characteristic	Symbol	Value	Unit
Power Dissipation (Note 3)	P _D	250	mW
Power Deration above 25°C	P _{der}	2	mW/°C
Thermal Resistance, Junction to Ambient Air (Note 3)	R _{θJA}	500	°C/W
Operation and Storage Temperature Range	T _J , T _{STG}	-55 to +150	°C

Electrical Characteristics @T_A = 25°C unless otherwise specified

Characteristic	Symbol	Min	Typ	Max	Unit	Test Condition
Collector-Base Breakdown Voltage	V _{(BR)CBO}	50	—	—	V	I _C = 10μA, I _E = 0
Collector-Emitter Breakdown Voltage	V _{(BR)CEO}	50	—	—	V	I _C = 1.0mA, I _B = 0
Collector-Base Cut Off Current	I _{CBO}	—	—	0.5	μA	V _{CB} = 50V, I _E = 0
Input Voltage	V _{I(OFF)}	—	1.2	0.5	V	V _{CE} = 5V, I _O = 100μA V _O = 0.3V, I _O = 2mA
	V _{I(ON)}	3	1.6	—		
Output Voltage	V _{O(ON)}	—	—	0.3	V	I _O /I _I = 10mA/0.5mA
Input Current	I _I	—	—	0.18	mA	V _I = 5V
Output Current	I _{O(OFF)}	—	—	0.5	μA	V _{CC} = 50V, V _I = 0V
DC Current Gain	G ₁	68	—	—	—	V _O = 5V, I _O = 5mA
Input Resistance	R ₁	32.9	47	61.1	kΩ	—
Resistance Ratio	R ₂ /R ₁	0.8	1	1.2	—	—
Transition Frequency*	f _T	—	250	—	MHz	V _{CE} = 10V, I _E = 5mA, f = 100MHz

* Characteristics of transistor only.

- Notes:
1. No purposefully added lead.
 2. Diodes Inc.'s "Green" policy can be found on our website at http://www.diodes.com/products/lead_free/index.php.
 3. Device mounted on FR-4 PCB, 1" x 0.85" x 0.062"; pad layout as shown on page 3 or Diodes Inc. suggested pad layout document AP02001, which can be found on our website at <http://www.diodes.com/datasheets/ap02001.pdf>.

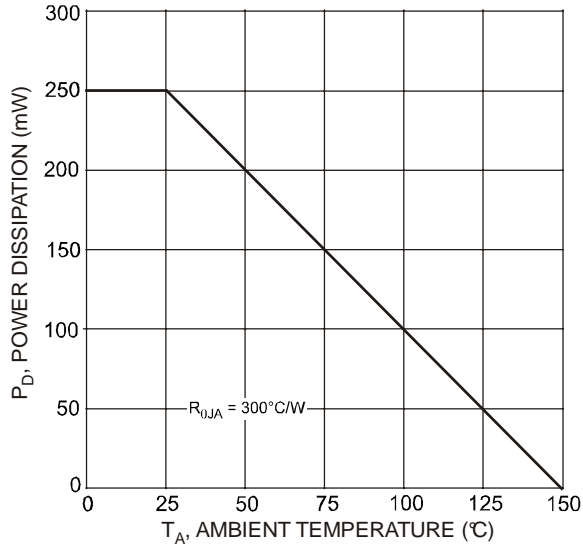

Fig. 1 Power Dissipation vs. Ambient Temperature (Note 3)

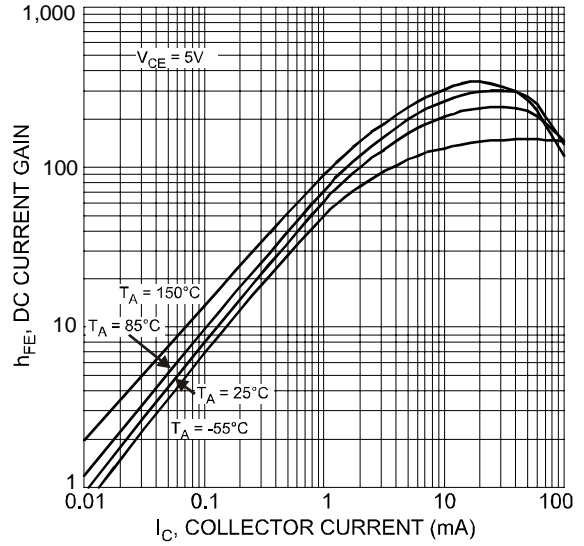

Fig. 2 Typical DC Current Gain vs. Collector Current

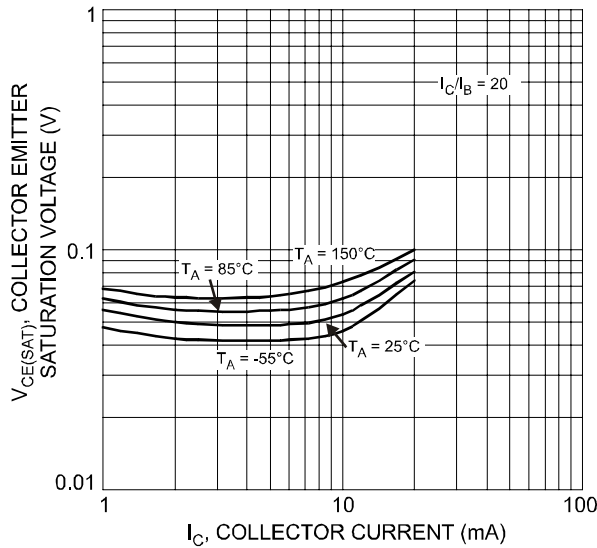

Fig. 3 Typical Collector-Emitter Saturation Voltage vs. Collector Current

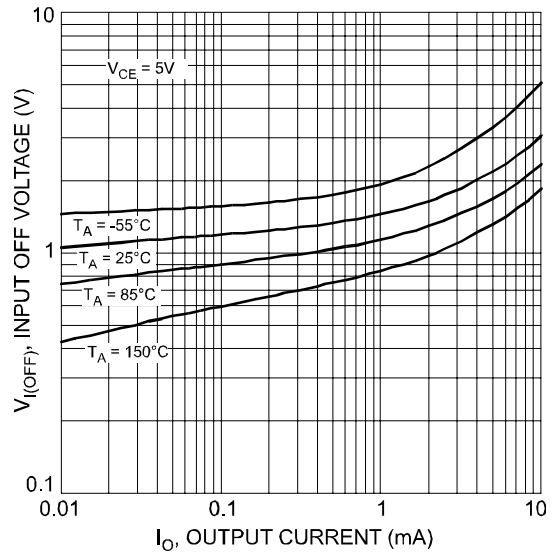

Fig. 4 Typical Input Off Voltage vs. Output Current

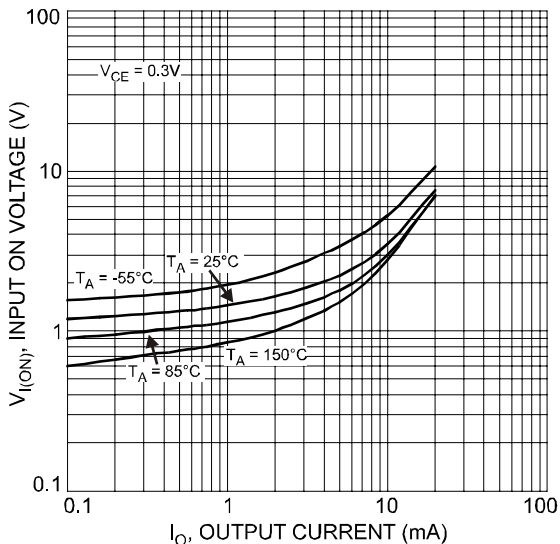

Fig. 5 Typical Input ON Voltage vs. Output Current

Ordering Information (Note 4)

Device	Packaging	Shipping
DDTC144ELP-7	DFN1006-3	3000/Tape & Reel

Notes: 4. For packaging details, go to our website at <http://www.diodes.com/ap2007.pdf>.

Marking Information

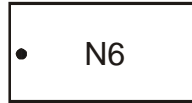

N6 = Product Type Marking Code
Dot Denotes Collector, Pin 3

Mechanical Details

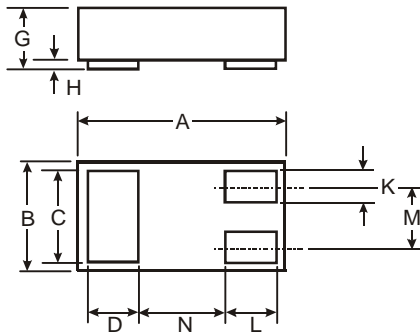

DFN1006-3			
Dim	Min	Max	Typ
A	0.95	1.075	1.00
B	0.55	0.675	0.60
C	0.45	0.55	0.50
D	0.20	0.30	0.25
G	0.47	0.53	0.50
H	0	0.05	0.03
K	0.10	0.20	0.15
L	0.20	0.30	0.25
M	—	—	0.35
N	—	—	0.40
All Dimensions in mm			

Suggested Pad Layout

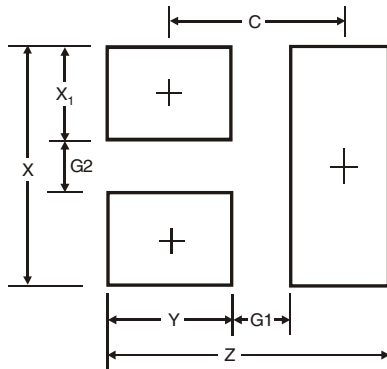

Dimensions	Value (in mm)
Z	1.1
G1	0.3
G2	0.2
X	0.7
X1	0.25
Y	0.4
C	0.7

IMPORTANT NOTICE

Diodes Incorporated and its subsidiaries reserve the right to make modifications, enhancements, improvements, corrections or other changes without further notice to any product herein. Diodes Incorporated does not assume any liability arising out of the application or use of any product described herein; neither does it convey any license under its patent rights, nor the rights of others. The user of products in such applications shall assume all risks of such use and will agree to hold Diodes Incorporated and all the companies whose products are represented on our website, harmless against all damages.

LIFE SUPPORT

Diodes Incorporated products are not authorized for use as critical components in life support devices or systems without the expressed written approval of the President of Diodes Incorporated.