

DDTC (R2-ONLY SERIES) E

NPN PRE-BIASED SMALL SIGNAL SURFACE MOUNT TRANSISTOR

Features

- Epitaxial Planar Die Construction
- Complementary PNP Types Available (DDTA)
- Built-In Biasing Resistor, R2 only
- **Lead Free/RoHS Compliant (Note 2)**
- **"Green" Device (Note 3 and 4)**

Mechanical Data

- Case: SOT-523
- Case Material: Molded Plastic. UL Flammability Classification Rating 94V-0
- Moisture Sensitivity: Level 1 per J-STD-020C
- Terminals: Solderable per MIL-STD-202, Method 208
- Lead Free Plating (Matte Tin Finish annealed over Alloy 42 leadframe).
- Terminal Connections: See Diagram
- Marking Information: See Table Below & Page 2
- Ordering Information: See Page 2
- Weight: 0.002 grams (approximate)

| P/N | R1 (NOM) | Marking |
|-----------|---------------|---------|
| DDTC114GE | 10K Ω | N26 |
| DDTC124GE | 22K Ω | N27 |
| DDTC144GE | 47K Ω | N28 |
| DDTC115GE | 100K Ω | N29 |

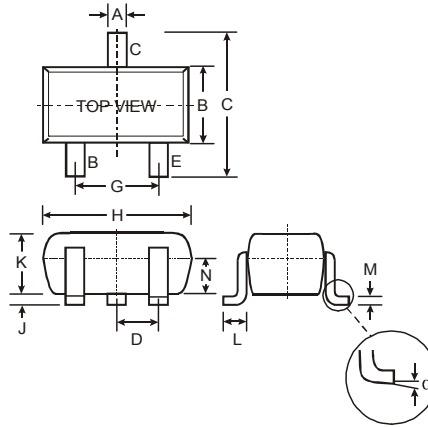

| SOT-523 | | | |
|----------------------|------|------|------|
| Dim | Min | Max | Typ |
| A | 0.15 | 0.30 | 0.22 |
| B | 0.75 | 0.85 | 0.80 |
| C | 1.45 | 1.75 | 1.60 |
| D | — | — | 0.50 |
| G | 0.90 | 1.10 | 1.00 |
| H | 1.50 | 1.70 | 1.60 |
| J | 0.00 | 0.10 | 0.05 |
| K | 0.60 | 0.80 | 0.75 |
| L | 0.10 | 0.30 | 0.22 |
| M | 0.10 | 0.20 | 0.12 |
| N | 0.45 | 0.65 | 0.50 |
| α | 0° | 8° | — |
| All Dimensions in mm | | | |

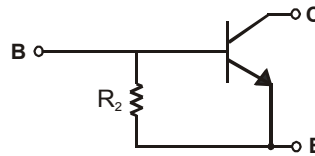

SCHMATIC DIAGRAM

Maximum Ratings @ $T_A = 25^\circ\text{C}$ unless otherwise specified

| Characteristic | Symbol | Value | Unit |
|--|-----------------|-------------|--------------------|
| Collector Base Voltage | V_{CBO} | 50 | V |
| Collector-Emitter Voltage | V_{CEO} | 50 | V |
| Emitter-Base Voltage | V_{EBO} | 5 | V |
| Collector Current | I_C (Max) | 100 | mA |
| Power Dissipation | P_d | 150 | mW |
| Thermal Resistance, Junction to Ambient Air (Note 1) | $R_{\theta JA}$ | 833 | $^\circ\text{C/W}$ |
| Operating and Storage and Temperature Range | T_J, T_{STG} | -55 to +150 | $^\circ\text{C}$ |

- Notes:
1. Mounted on FR4 PC Board with recommended pad layout, which can be found on our website at <http://www.diodes.com/datasheets/ap02001>.
 2. No purposefully added lead.
 3. Diodes Inc.'s "Green" policy can be found on our website at http://www.diodes.com/products/lead_free/index.php.
 4. Product manufactured with Date Code UO (week 40, 2007) and newer are built with Green Molding Compound. Product manufactured prior to Date Code UO are built with Non-Green Molding Compound and may contain Halogens or Sb2O3 Fire Retardants.

Electrical Characteristics @T_A = 25°C unless otherwise specified

| Characteristic | | Symbol | Min | Typ | Max | Unit | Test Condition |
|--|-----------|----------------------|-----|-----|-----|------|--|
| Collector-Base Breakdown Voltage | | BV _{CB0} | 50 | — | — | V | I _C = 50μA |
| Collector-Emitter Breakdown Voltage | | BV _{CEO} | 50 | — | — | V | I _C = 1mA |
| Emitter-Base Breakdown Voltage | | BV _{EBO} | 5 | — | — | V | I _E = 720μA, DDTC114GE I _E = 330 μA, DDTC124GE I _E = 160 μA, DDTC144GE I _E = 72 μA, DDTC115GE |
| Collector Cutoff Current | | I _{CBO} | — | — | 0.5 | μA | V _{CB} = 50V |
| Emitter Cutoff Current | DDTC114GE | I _{EBO} | 300 | — | 580 | μA | V _{EB} = 4V |
| | DDTC124GE | | 140 | | 260 | | |
| | DDTC144GE | | 65 | | 130 | | |
| | DDTC115GE | | 30 | | 58 | | |
| Collector-Emitter Saturation Voltage | | V _{CE(sat)} | — | — | 0.3 | V | I _C = 10mA, I _B = 0.5mA |
| DC Current Transfer Ratio | DDTC114GE | h _{FE} | 30 | — | — | — | I _C = 5mA, V _{CE} = 5V |
| | DDTC124GE | | 56 | | | | |
| | DDTC144GE | | 68 | | | | |
| | DDTC115GE | | 82 | | | | |
| Bleeder Resistor (R ₂) Tolerance | | ΔR ₂ | -30 | — | +30 | % | — |
| Gain-Bandwidth Product* | | f _T | — | 250 | — | MHz | V _{CE} = 10V, I _E = -5mA, f = 100MHz |

* Transistor – For Reference Only

TYPICAL CURVES – DDTC114GE

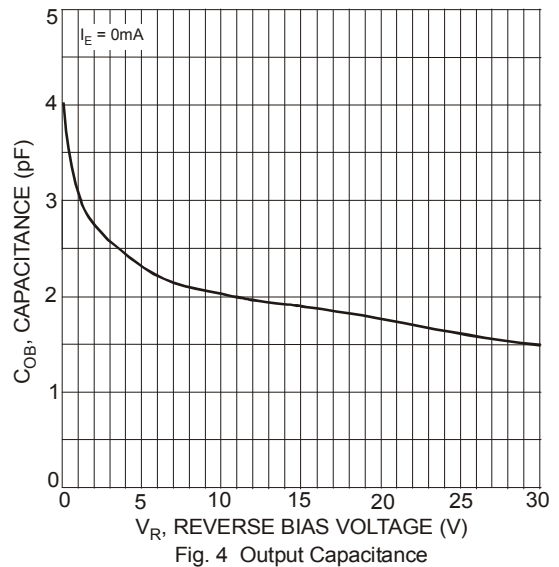
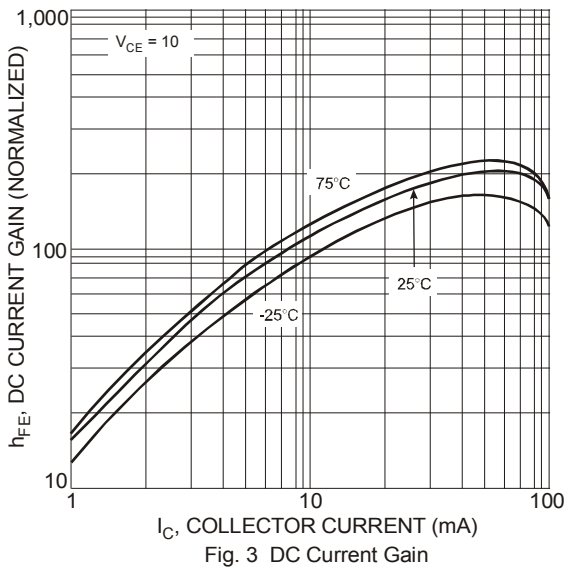
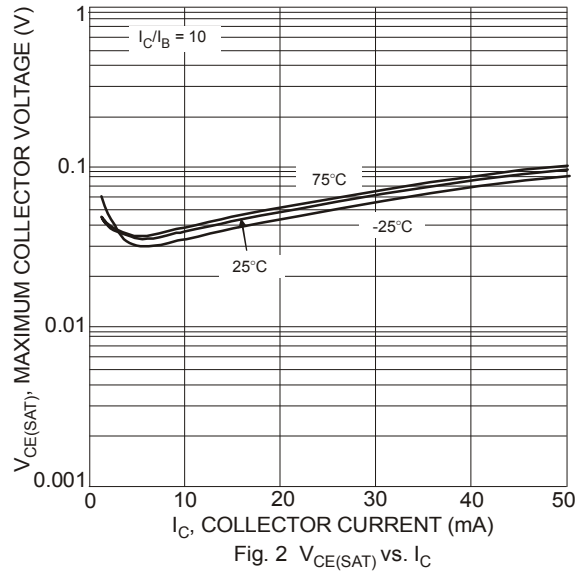
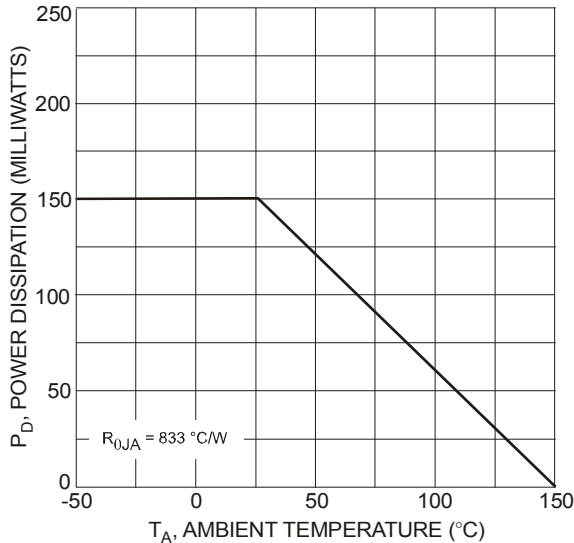

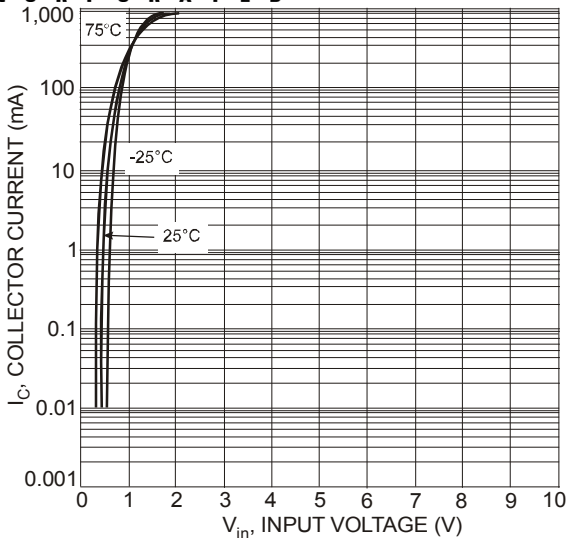

Fig. 5 Collector Current vs. Input Voltage

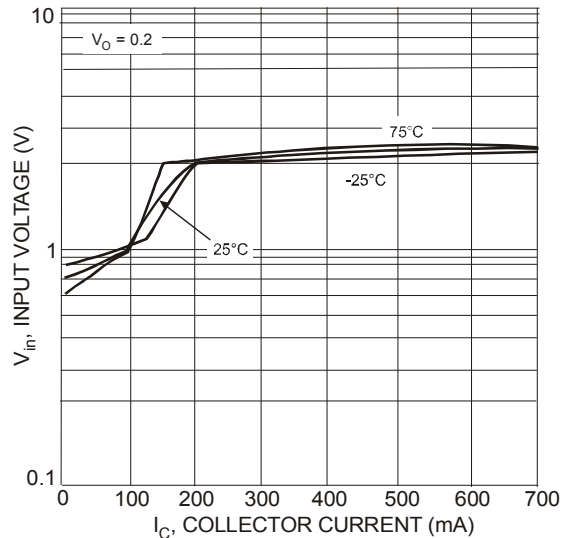

Fig. 6 Input Voltage vs. Collector Current

Ordering Information (Note 5)

| Device | Packaging | Shipping |
|----------------|-----------|--------------------|
| DDTC1xxGE-7-F | SOT-523 | 3000/Tape & Reel |
| DDTC1xxGE-13-F | SOT-523 | 10,000/Tape & Reel |

Notes: 5. For packaging details, go to our website at <http://www.diodes.com/datasheets/ap02007.pdf>.

Marking Information

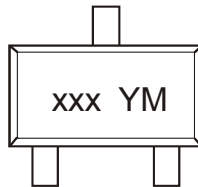

xxx = Product Type Marking Code (See Page 1, e.g. N26 = DDTC114GE)
 YM = Date Code Marking
 Y = Year (ex: T = 2006)
 M = Month (ex: 9 = September)

Date Code Key

| Year | 2006 | 2007 | 2008 | 2009 | 2010 | 2011 | 2012 |
|------|------|------|------|------|------|------|------|
| Code | T | U | V | W | X | Y | Z |

| Month | Jan | Feb | Mar | Apr | May | Jun | Jul | Aug | Sep | Oct | Nov | Dec |
|-------|-----|-----|-----|-----|-----|-----|-----|-----|-----|-----|-----|-----|
| Code | 1 | 2 | 3 | 4 | 5 | 6 | 7 | 8 | 9 | O | N | D |

IMPORTANT NOTICE

Diodes Incorporated and its subsidiaries reserve the right to make modifications, enhancements, improvements, corrections or other changes without further notice to any product herein. Diodes Incorporated does not assume any liability arising out of the application or use of any product described herein; neither does it convey any license under its patent rights, nor the rights of others. The user of products in such applications shall assume all risks of such use and will agree to hold Diodes Incorporated and all the companies whose products are represented on our website, harmless against all damages.

LIFE SUPPORT

Diodes Incorporated products are not authorized for use as critical components in life support devices or systems without the expressed written approval of the President of Diodes Incorporated.