

**Features**

- Epitaxial Planar Die Construction
- Complementary NPN Types Available (DDTD)
- Built-In Biasing Resistors
- **Lead Free/RoHS Compliant (Note 2)**
- **"Green" Device (Note 3 & 4)**

**Mechanical Data**

- Case: SOT-323
- Case Material: Molded Plastic, "Green" Molding Compound, Note 4. UL Flammability Classification Rating 94V-0
- Moisture Sensitivity: Level 1 per J-STD-020C
- Terminals: Solderable per MIL-STD-202, Method 208
- Terminal Connections: See Diagram
- Lead Free Plating (Matte Tin Finish annealed over Alloy 42 leadframe)
- Marking Information: See Table Below & Page 3
- Ordering Information: See Page 3
- Weight: 0.006 grams (approximate)

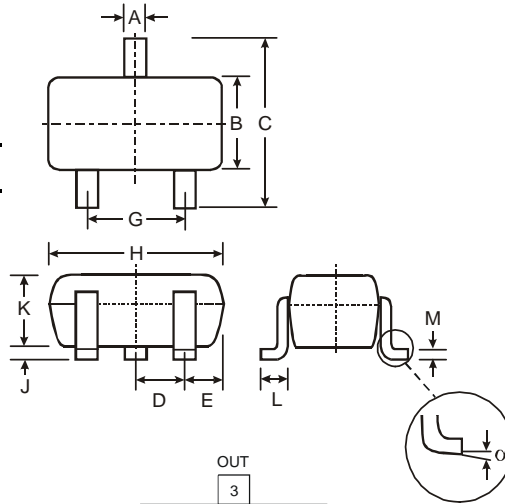

SOT-323		
Dim	Min	Max
A	0.25	0.40
B	1.15	1.35
C	2.00	2.20
D	0.65 Nominal	
E	0.30	0.40
G	1.20	1.40
H	1.80	2.20
J	0.0	0.10
K	0.90	1.00
L	0.25	0.40
M	0.10	0.18
α	0°	8°

All Dimensions in mm

P/N	R1 (NOM)	R2 (NOM)	Type Code
DDTB122LU	0.22KΩ	10KΩ	P75
DDTB142JU	0.47KΩ	10KΩ	P76
DDTB122TU	0.22KΩ	OPEN	P77
DDTB142TU	0.47KΩ	OPEN	P78

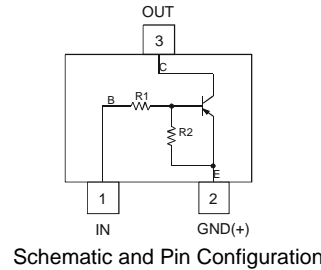

**Maximum Ratings** @T<sub>A</sub> = 25°C unless otherwise specified

Characteristic	Symbol	Value	Unit
Supply Voltage, (3) to (2)	V <sub>CC</sub>	-50	V
Input Voltage, (1) to (2)	V <sub>IN</sub>	+5 to -6	V
Input Voltage, (2) to (1)	V <sub>EBO (MAX)</sub>	-5	V
Output Current	I <sub>C</sub>	-500	mA
Power Dissipation	P <sub>d</sub>	200	mW
Thermal Resistance, Junction to Ambient Air	R <sub>θJA</sub>	625	°C/W
Operating and Storage Temperature Range	T <sub>j</sub> , T <sub>STG</sub>	-55 to +150	°C

- Notes:
1. Mounted on FR4 PC Board with recommended pad layout at <http://www.diodes.com/datasheets/ap02001.pdf>.
  2. No purposefully added lead.
  3. Diodes Inc.'s "Green" policy can be found on our website at [http://www.diodes.com/products/lead\\_free/index.php](http://www.diodes.com/products/lead_free/index.php).
  4. Product manufactured with Date Code 0627 (week 27, 2006) and newer are built with Green Molding Compound. Product manufactured prior to Date Code 0627 are built with Non-Green Molding Compound and may contain Halogens or Sb2O3 Fire Retardants.

**Electrical Characteristics**

 @T<sub>A</sub> = 25°C unless otherwise specified

**R1, R2 Types**

Characteristic		Symbol	Min	Typ	Max	Unit	Test Condition
Input Voltage	DDTB122LU DDTB142JU	V <sub>I(off)</sub>	-0.3 -0.3	—	—	V	V <sub>CC</sub> = -5V, I <sub>O</sub> = -100μA
	DDTB122LU DDTB142JU	V <sub>I(on)</sub>	—	—	-2.0 -2.0	V	V <sub>O</sub> = -0.3V, I <sub>O</sub> = -20mA V <sub>O</sub> = -0.3V, I <sub>O</sub> = -20mA
Output Voltage		V <sub>O(on)</sub>	—	—	-0.3V	V	I <sub>O</sub> /I <sub>I</sub> = -50mA/-2.5mA
Input Current	DDTB122LU DDTB142JU	I <sub>I</sub>	—	—	-28 -13	mA	V <sub>I</sub> = -5V
Output Current		I <sub>O(off)</sub>	—	—	-0.5	μA	V <sub>CC</sub> = -50V, V <sub>I</sub> = 0V
DC Current Gain	DDTB122LU DDTB142JU	G <sub>I</sub>	56 56	—	—	—	V <sub>O</sub> = -5V, I <sub>O</sub> = -50mA
Gain-Bandwidth Product*		f <sub>T</sub>	—	200	—	MHz	V <sub>CE</sub> = -10V, I <sub>E</sub> = -5mA, f = 100MHz

\* Transistor - For Reference Only

**Electrical Characteristics**

 @T<sub>A</sub> = 25°C unless otherwise specified

**R1 – Only Types**

Characteristic		Symbol	Min	Typ	Max	Unit	Test Condition
Collector-Base Breakdown Voltage		BV <sub>CB0</sub>	-50	—	—	V	I <sub>C</sub> = -50μA
Collector-Emitter Breakdown Voltage		BV <sub>CEO</sub>	-40	—	—	V	I <sub>C</sub> = -1mA
Emitter-Base Breakdown Voltage	DDTB122TU DDTB142TU	BV <sub>EBO</sub>	-5	—	—	V	I <sub>E</sub> = -50μA I <sub>E</sub> = -50μA
Collector Cutoff Current		I <sub>CB0</sub>	—	—	-0.5	μA	V <sub>CB</sub> = -50V
Emitter Cutoff Current	DDTB122TU DDTB142TU	I <sub>EBO</sub>	— —	—	-0.5 -0.5	μA	V <sub>EB</sub> = -4V
Collector-Emitter Saturation Voltage		V <sub>CE(sat)</sub>	—	—	-0.3	V	I <sub>C</sub> = -50mA, I <sub>B</sub> = -2.5mA
DC Current Transfer Ratio	DDTB122TU DDTB142TU	h <sub>FE</sub>	100 100	250 250	600 600	—	I <sub>C</sub> = -5mA, V <sub>CE</sub> = -5V
Gain-Bandwidth Product*		f <sub>T</sub>	—	200	—	MHz	V <sub>CE</sub> = -10V, I <sub>E</sub> = 5mA, f = 100MHz

\* Transistor - For Reference Only

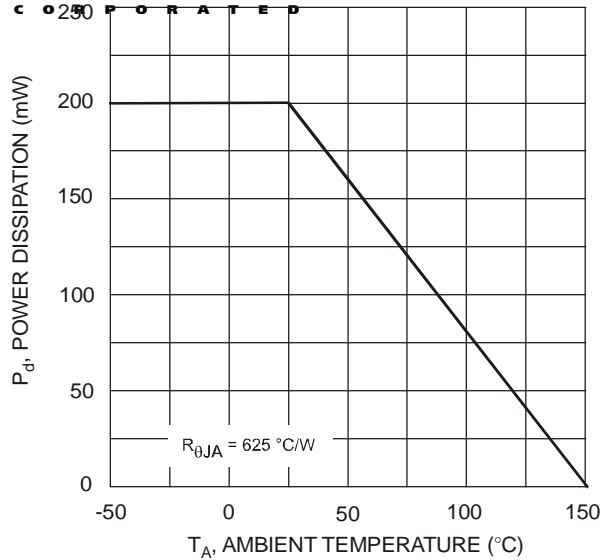

Fig. 1 Power Derating Curve

## Ordering Information (Note 4 & 5)

Device	Packaging	Shipping
DDTB122LU-7-F	SOT-323	3000/Tape & Reel
DDTB142JU-7-F	SOT-323	3000/Tape & Reel
DDTB122TU-7-F	SOT-323	3000/Tape & Reel
DDTB142TU-7-F	SOT-323	3000/Tape & Reel

Notes: 5. For packaging details, go to our website at <http://www.diodes.com/datasheets/ap02007.pdf>.

## Marking Information

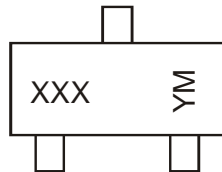

XXX = Product Type Marking Code (See Page 1)  
 YM = Date Code Marking  
 Y = Year ex: T = 2006  
 M = Month ex: 9 = September

### Date Code Key

Year	2006	2007	2008	2009	2010	2011	2012
Code	T	U	V	W	X	Y	Z

Month	Jan	Feb	Mar	Apr	May	Jun	Jul	Aug	Sep	Oct	Nov	Dec
Code	1	2	3	4	5	6	7	8	9	O	N	D

### IMPORTANT NOTICE

Diodes Incorporated and its subsidiaries reserve the right to make modifications, enhancements, improvements, corrections or other changes without further notice to any product herein. Diodes Incorporated does not assume any liability arising out of the application or use of any product described herein; neither does it convey any license under its patent rights, nor the rights of others. The user of products in such applications shall assume all risks of such use and will agree to hold Diodes Incorporated and all the companies whose products are represented on our website, harmless against all damages.

### LIFE SUPPORT

Diodes Incorporated products are not authorized for use as critical components in life support devices or systems without the expressed written approval of the President of Diodes Incorporated.