

Features

- Target CMX910 installed
- Auxiliary ADC and DAC interface
- Digital/analogue PCB with low noise floor
- Differential and single-ended baseband interface
- FX604 FSK modem IC fitted for extra Rx channel
- C-BUS interface
- 19.2MHz device clock
- Interfaces to RF daughterboard with all necessary signals
- On-board power regulation and distribution

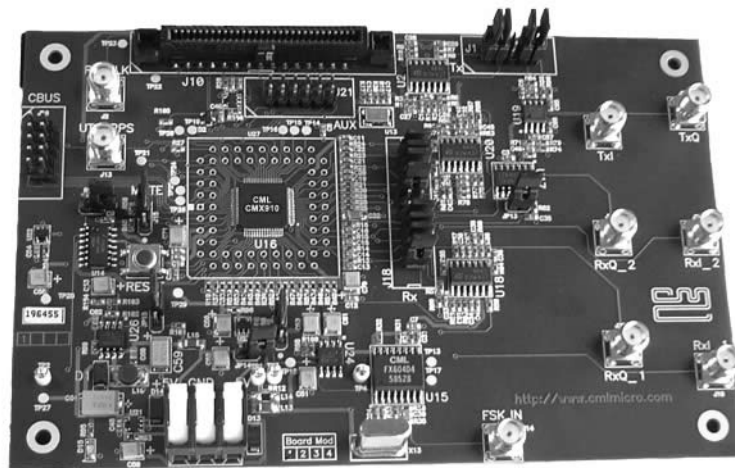

1 Brief Description

The EV9100 evkit is available for the evaluation, experimentation and design-in of the CMX910 AIS Baseband Processor IC.

Comprising a digital/analogue pcb with an on-board CMX910 device, the evkit provides access to the CMX910's baseband signal, control and data interfaces as well as its auxilliary ADC and DAC functions. The evkit also provides an FX604 FSK modem and associated circuitry to allow evaluation of the CMX910's external FSK interface.

Jumpers, links and test points allow the user to dynamically monitor and/or isolate all aspects of the IC's signal and voltage levels.

This evkit has a simple power requirement with on-board voltage regulation and distribution.

<u>Section</u>	CONTENTS	<u>Page</u>
1	Brief Description	1
2.	Preliminary Information.....	4
2.1	Laboratory Equipment.....	4
2.2	Handling Precautions.....	4
2.3	Approvals.....	4
3.	Quick Start	4
4.	Signal Lists	5
5.	Circuit Schematics and Board Layouts.....	11
6.	Detailed Description	12
6.1	Hardware Description.....	12
6.2	Firmware Description	13
6.3	Software Description.....	13
6.4	Evaluation Tests	13
7.	Performance Specification.....	14
7.1	Electrical Performance.....	14

It is always recommended that you check for the latest product datasheet version from the Datasheets page of the CML website: [www.cmlmicro.com].

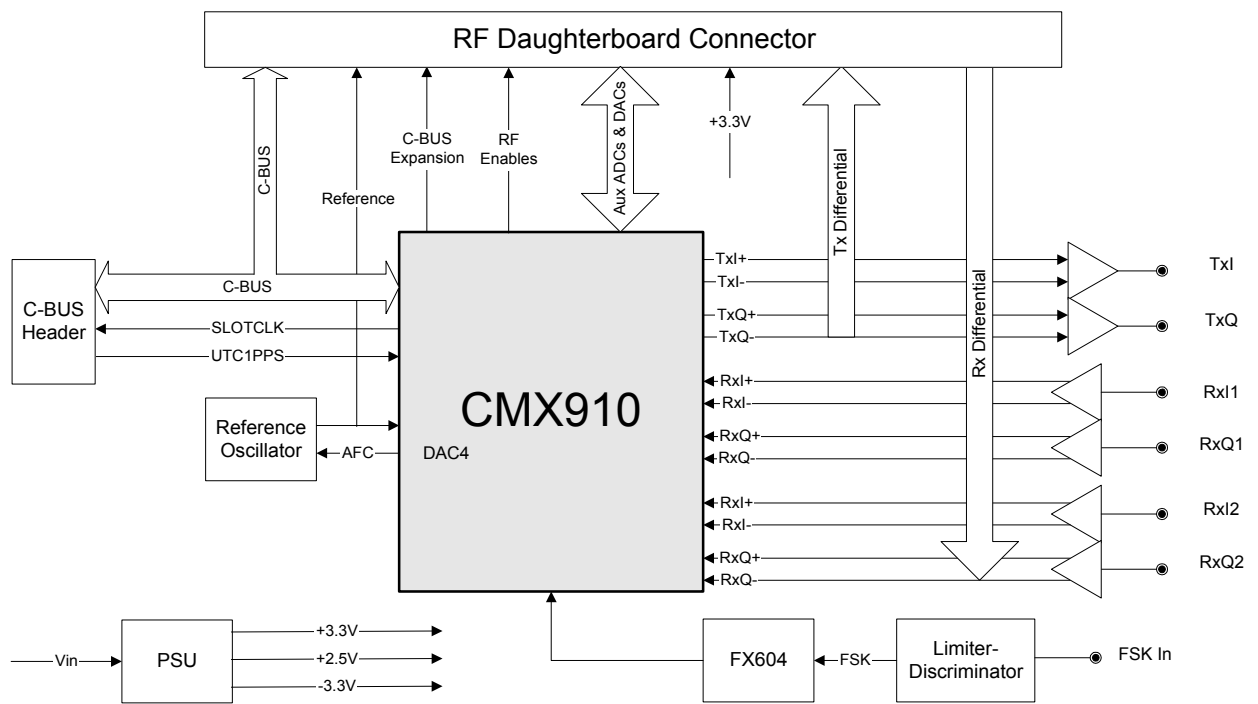

Figure 1 Block Diagram

2. Preliminary Information

2.1 Laboratory Equipment

The following laboratory equipment is needed to use this evaluation kit:

2.1.1 Power Supply

+5V, -6V.

The -6V supply is optional, as the EV9100 incorporates a negative voltage generator. The board is supplied with JP2 jumpered between pins 1 and 2, which connects the negative supply to the on-board negative voltage generator, rather than the -6V external supply.

2.1.2 Signal Generators and Analysers

Suitable AIS Baseband I and Q signals must be generated by external equipment connected to this Evaluation Kit. The signals produced by this kit must also be analysed by external equipment. Provision is also made on this kit for connections to the Auxiliary ADC and DAC and digital Device Enable Ports. A multi-way connector, J10, allows for the connection of a (customer-supplied) daughter card containing RF circuitry.

2.1.3 C-BUS Control

This Evaluation Kit is controlled by a (customer-supplied) host μ Controller, via the C-BUS connector, J16. This is a 3.3V digital logic serial interface, which can be connected to a host μ Controller's SPI port. There is no firmware or software supplied with this Evaluation Kit.

2.2 Handling Precautions

Like most evaluation kits, this product is designed for use in office and laboratory environments. The following practices will help ensure its proper operation.

2.2.1 Static Protection

This product uses low power CMOS circuits which can be damaged by electrostatic discharge. Partially damaged circuits can function erroneously, leading to misleading results. Observe ESD precautions at all times when handling this product.

2.2.2 Contents - Unpacking

Please ensure that you have received all of the items on the separate information sheet (EK9100) and notify CML within 7 working days if the delivery is incomplete.

2.3 Approvals

There are no approvals for this product.

3. Quick Start

Customers should assemble all of the equipment required to demonstrate the CMX910 and connect it to the Evaluation Kit before applying power to the kit. Power should be applied to this kit before the host μ Controller is powered-up. Consult sections 6 and 7.1.3 of this User Manual for details of the analogue and digital signal levels.

4. Signal Lists

CONNECTOR PINOUT				
Connector Ref	Connector Pin No.	Signal Name	Signal Type	Description
J26	1	-Vin	Power	Optional -ve power supply. +ve power supply.
J26	2	DGND	Power	
J26	3	+Vin	Power	
J16	1	CSN	I/P	Active low chip select.
J16	2	CSXN	I/P	Active low chip select expansion input.
J16	3	CDATA	I/P	Command Data (Data from host to CMX910).
J16	4	SLOTCLKN	O/P	Active low AIS Slot Clock.
J16	5	SCLK	I/P	Serial Clock.
J16	6	UTC1PPS	I/P	1Hz clock signal from GPS unit to CMX910.
J16	7	RDATA	O/P	Reply data (Data from CMX910 to host).
J16	8	RESETN	I/P	Active low reset.
J16	9	IRQN	O/P	Active low interrupt. This is an open drain output from the CMX910.
J16	10	DGND	Power	

CONNECTOR PINOUT				
Connector Ref.	Connector Pin No.	Signal Name	Signal Type	Description
Note: On J18, odd-numbered pins are outputs from the single-to-differential op-amps. Even-numbered pins are inputs to the CMX910. See also the table of jumper settings.				
J18	1, 2	Rx1IN	O/P - I/P	Channel 1 Rx I Negative
J18	3, 4	Rx1IP	O/P - I/P	Channel 1 Rx I Positive
J18	5, 6	Rx1QN	O/P - I/P	Channel 1 Rx Q Negative
J18	7, 8	Rx1QP	O/P - I/P	Channel 1 Rx Q Positive
J18	9, 10, 11, 12	AGND	Power	
J18	13, 14	Rx2IN	O/P - I/P	Channel 2 Rx I Negative
J18	15, 16	Rx2IP	O/P - I/P	Channel 2 Rx I Positive
J18	17, 18	Rx2QN	O/P - I/P	Channel 2 Rx Q Negative
J18	19, 20	Rx2QP	O/P - I/P	Channel 2 Rx Q Positive
J19		Rx1I	I/P	Channel 1 Rx I
J20		Rx1Q	I/P	Channel 1 Rx Q
J23		Rx2I	I/P	Channel 2 Rx I
J25		Rx2Q	I/P	Channel 2 Rx Q

CONNECTOR PINOUT				
Connector Ref.	Connector Pin No.	Signal Name	Signal Type	Description
Note: On J1, Odd-numbered pins are buffered outputs from the CMX910. Even-numbered pins are inputs to the differential-to-single op-amps. See also the table of jumper settings.				
J1	1, 2	TxIN	O/P - I/P	Tx I Negative
J1	3, 4	TxIP	O/P - I/P	Tx I Positive
J1	5, 6	AGND	Power	
J1	7, 8	TxQN	O/P - I/P	Tx Q Negative
J1	9, 10	TxQP	O/P - I/P	Tx Q Positive
J14		FSK IN	I/P	FSK input
J22		TxI	O/P	TxI Single ended
J24		TxQ	O/P	TxQ Single ended
J21	1	Aux ADC 0	I/P	Auxillary ADC 0 Input
J21	2	Aux ADC 1	I/P	Auxillary ADC 1 Input
J21	3	Aux ADC 2	I/P	Auxillary ADC 2 Input
J21	4	Aux ADC 3	I/P	Auxillary ADC 3 Input
J21	5	Aux ADC 4	I/P	Auxillary ADC 4 Input
J21	6, 7	AGND	Power	
J21	8	Aux DAC 0	O/P	Auxillary DAC 0 Output
J21	9	Aux DAC 1	O/P	Auxillary DAC 1 Output
J21	10	Aux DAC 2	O/P	Auxillary DAC 2 Output
J21	11	Aux DAC 3	O/P	Auxillary DAC 3 Output
J21	12	Aux DAC 4	O/P	Auxillary DAC 4 Output

CONNECTOR PINOUT				
Connector Ref.	Connector Pin No.	Signal Name	Signal Type	Description
J10	1	CDATA	I/P	Command Data
J10	2	SCLK	I/P	Serial Clock
J10	3	EXP1N	I/P	CBUS expansion 1
J10	4	EXP3N	I/P	CBUS expansion 3
J10	5	DGND	Power	Digital Ground
J10	6	EXP4N	I/P	CBUS expansion 4
J10	7	ENAB0	O/P	RF Enable 0
J10	8	ENAB2	O/P	RF Enable 2
J10	9	ENAB4	O/P	RF Enable 4
J10	10	DGND	Power	Digital Ground
J10	11	UTC1PPS	I/P	1Hz GPS clock
J10	12	DGND	Power	Digital Ground
J10	13	FSK_RXD	I/P	Demodulated FSK data
J10	14	DGND	Power	Digital Ground
J10	15	DGND	Power	Digital Ground
J10	16	AGND	Power	Analogue Ground
J10	17	VREF_EXT	I/P	External Voltage Ref.
J10	18	AUXADC1	I/P	Aux ADC 1 Input
J10	19	AUXADC3	I/P	Aux ADC 3 Input
J10	20	AGND	Power	Analogue Ground
J10	21	AUXDAC1	O/P	Aux DAC 1 Output
J10	22	AUXDAC3	O/P	Aux DAC 3 Output
J10	23	AGND	Power	Analogue Ground
J10	24	RX1IP	I/P	Ch 1 Rx I Positive
J10	25	RX1QP	I/P	Ch 1 Rx Q Positive
J10	26	RX2IN	I/P	Ch 2 Rx I Negative
J10	27	RX2QN	I/P	Ch 2 Rx Q Negative
J10	28	AGND	Power	Analogue Ground
J10	29	TXIP	O/P	Tx I Positive
J10	30	TXQP	O/P	Tx Q Positive

continued overleaf ...

CONNECTOR PINOUT				
Connector Ref.	Connector Pin No.	Signal Name	Signal Type	Description
J10	31	AGND	Power	Analogue Ground
J10	32	TXQN	O/P	Tx Q Negative
J10	33	TXIN	O/P	Tx I Negative
J10	34	RX2QP	I/P	Ch 2 Rx Q Positive
J10	35	RX2IP	I/P	Ch 2 Rx I Positive
J10	36	AGND	Power	Analogue Ground
J10	37	RX1QN	I/P	Ch 1 Rx Q Negative
J10	38	RX1IN	I/P	Ch 1 Rx I Negative
J10	39	AUXDAC4	O/P	Aux DAC 4 Output
J10	40	AUXDAC2	O/P	Aux DAC 2 Output
J10	41	AUXDAC0	O/P	Aux DAC 0 Output
J10	42	AUXADC4	I/P	Aux ADC 4 Input
J10	43	AUXADC2	I/P	Aux ADC 2 Input
J10	44	AUXADC0	I/P	Aux ADC 0 Input
J10	45	FSK_IN	I/P	FSK Modulation
J10	46	+VIN	Power	Unregulated Supply
J10	47	+3V3_EXT	O/P	+3.3V supply, 100mA maximum
J10	48	FSK_MUTE	I/P	Logic Input
J10	49	FSK_DET	I/P	Logic Input
J10	50	REFCLK	O/P	CMX910 Clock
J10	51	nSLOTCLK	O/P	AIS Slot Clock
J10	52	ENAB5	O/P	RF Enable 5
J10	53	ENAB3	O/P	RF Enable 3
J10	54	ENAB1	O/P	RF Enable 1
J10	55	nEXP5	I/P	CBUS expansion 5
J10	56	DGND	Power	Digital Ground
J10	57	IRQN	O/P	Active low interrupt
J10	58	EXP2N	I/P	CBUS expansion 2
J10	59	EXP0N	I/P	CBUS expansion 0
J10	60	RDATA	O/P	Reply data

TEST POINTS		
Test Point Ref.	Default Measurement	Description
TP1, 2	0V	Digital ground
TP3, 4	0V	Analogue ground
TP27	3.3V	3.3V digital supply
TP28	3.3V	3.3V external supply
TP29	2.5V	2.5V digital supply

JUMPERS			
Link Ref.	Positions	Default Position	Description
J15	1-2, 2-3	2-3	FSK_MUTE select. 1-2 is high, disabling CMX910 interface, 2-3 is low, enabling CMX910 interface.
J18	1-2, 3-4, 5-6, 7-8	All fitted	Connect single-to-differential op-amp circuit outputs for Rx Channel 1 to CMX910, if fitted.
J18	13-14, 15-16, 17-18, 19-20	All fitted	Connect single-to-differential op-amp circuit outputs for Rx Channel 2 to CMX910, if fitted.
J1	1-2, 3-4, 7-8, 9-10	All fitted	Connect CMX910 Tx outputs to differential-to-single op-amp circuit inputs, if fitted.
JP1	1-2	Not Fitted	If fitted, the tri-state buffers between the FX604 and the CMX910 will be disabled i.e. their outputs will be high impedance.
JP2	1-2, 2-3	1-2	Negative voltage supply selection. 1-2 is on-board switched-mode supply, 2-3 is external supply.
JP13	1-2	Fitted	Voltage reference select. If fitted, the CMX910's internal reference will be used as a reference for the differential-to-single Tx op-amp circuit. If not fitted, then an external reference can be supplied from the RF transceiver interface (J10).
JP14	1-2	Not Fitted	External regulator control. If fitted, an external 2.5V regulator will be enabled. This is not necessary for normal operation.
JP15	1-2	Not Fitted	If a jumper is fitted to JP15 then the negative voltage converter will be shut down. Default state is not fitted.

Notes: I/P = Input
O/P = Output
BI = Bidirectional

5. Circuit Schematics and Board Layouts

For clarity, circuit schematics are available in this kit as separate high resolution files.

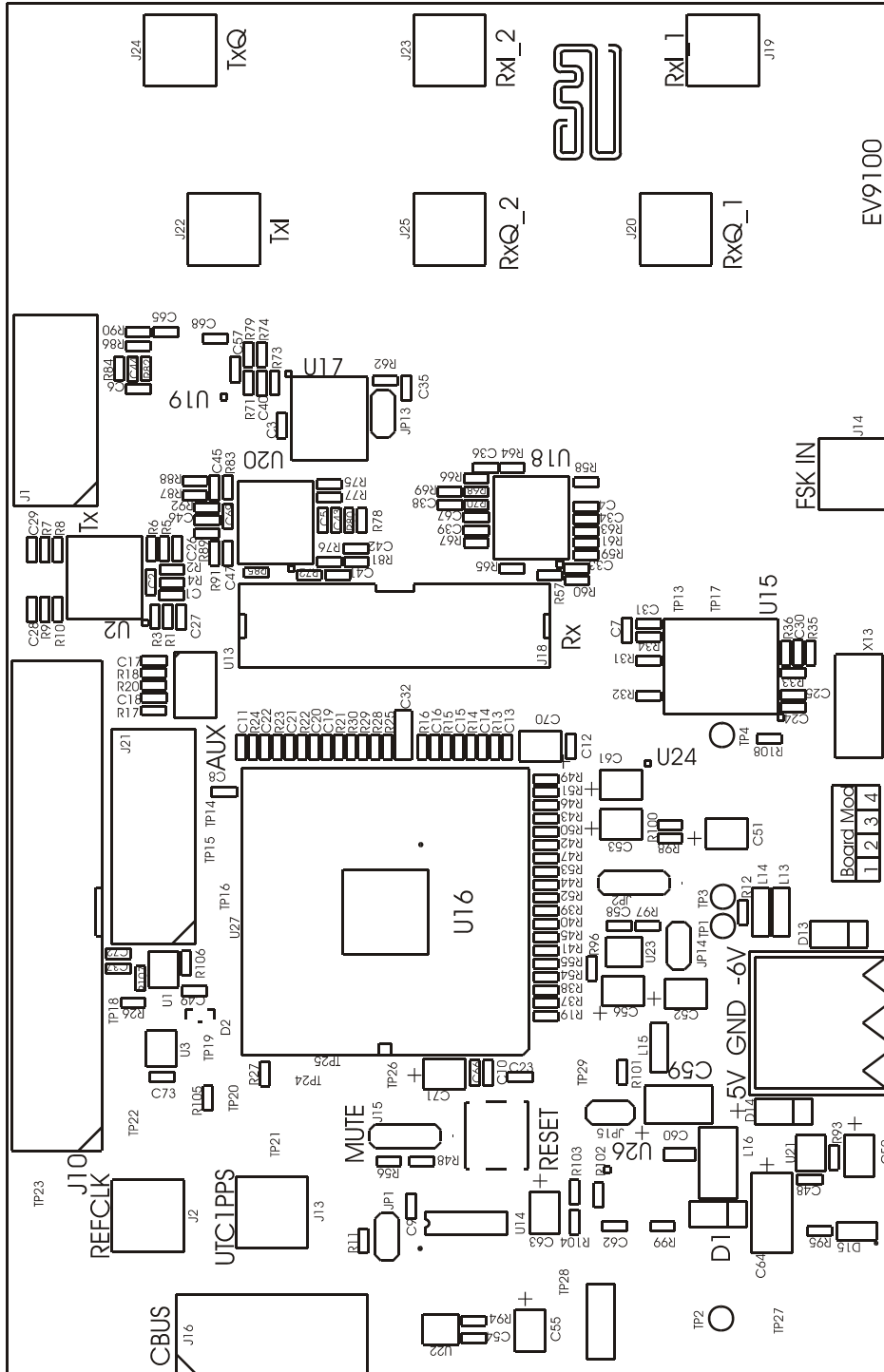

Figure 2 Evaluation Board - Layout

6. Detailed Description

6.1 Hardware Description

6.1.1 CMX910

The EV9100 comprises a CMX910 device mounted on a PCB with convenient interfaces so that users can rapidly develop their own CMX910 prototype circuits and make connections to user-provided external circuits. Refer to the CMX910 data sheet for a detailed description of the IC's operation.

The CMX910 is a highly integrated baseband signalling processor IC, which meets the requirements of the class A and class B marine Automatic Identification System (AIS) transponder market. It is half duplex in operation, comprising two parallel I+Q Rx paths and one Tx path. These are configurable for AIS or FSK (DSC) operation. A 1200bps FSK demodulator interface provides the third parallel decode path required by the AIS class A market. Integrated Rx/Tx data buffers and a slot/sample timer are also provided, reducing the processing required by the host μ C. A C-BUS expansion port, an RF device enable port and a number of auxiliary ADCs and DACs are also provided. There is a push-to-make switch on the pcb, connected to the CMX910's nRESET pin.

6.1.2 Oscillator

The clock for the CMX910 is provided by a 19.2MHz VCTCXO. By default its control input is held at mid-rail, but it can be tuned using the CMX910 AuxDAC4. If this is required, fit a 5k6 Ω resistor in position R19.

6.1.3 Rx Signal Conditioning

The Rx inputs to the CMX910 are differential. The header J18 can be used to apply differential signals (max 0.85Vpp per pin, centred at 1.25V) via anti-alias filters. Alternatively, jumpers can be fitted to J18 and single ended signals applied to the SMA connectors J19 and J20 (Ch1) and/or J23 and J25 (Ch2). On-board op-amps (U18, U20) then perform single-ended to differential conversion and shift the signal to the appropriate DC level. The signals applied to the SMA connectors should be DC coupled and centred about 0V. Maximum signal level at the SMA connectors is 0.85Vpp.

6.1.4 Tx Signal Conditioning

The Tx outputs from the CMX910 are differential. These signals pass through an RC filter and a buffer and are available on J1. Alternatively, jumpers can be fitted on J1 and on-board op-amps (U19) then perform differential to single-ended conversion and level shifting. The single-ended outputs are available on SMA connectors J22 and J24. These signals are centred about 0V and are capable of driving a 50 Ω load. These outputs are not designed to drive large capacitive loads.

6.1.5 FX604

The EV9100 has an FX604 FSK modem IC interfaced to the CMX910's 1200bps FSK demodulator interface. The FX604 is enabled by an inverted version of the signal ENAB3. This is to ensure that the FX604 powers up in the ZP mode. The CMX910's FSK_MUTE pin can be manually pulled up or down via J15, or driven from the RF transceiver interface. This is likely to be driven by a 'squelch' output from a limiter-discriminator. The FX604 outputs can be isolated from the CMX910 by fitting a jumper to JP1. The input to this circuit is an SMA connector, J14.

6.1.6 Digital Interface

Digital signals can be found on J16. These include the C-BUS interface, as well as some discrete logic signals. All digital signals use 3.3V levels.

6.1.7 RF Transceiver Interface

J10 is intended to allow the connection of a daughter card containing RF circuitry. This connector is manufactured by JAE and has the part number TX14-60R-6ST-MH1 (Mod State 1 and 2) or TX24-60R-6ST-H1E (Mod State 3 and later). The mating half is part number TX15-60P-6ST-MH1 or TX25-60P-6ST-H1E, respectively. In the UK they can be purchased from RS or Farnell Electronic Components. Note that this connector is numbered 1-30 along one edge, then 31-60 in the opposite direction along the other edge.

6.1.8 Power Distribution System

The EV9100 is designed to be operated from a single +5V (nominal) supply. The EV9100 circuitry runs from +3.3V and +2.5V supplies which are generated using on board linear regulators. There is also an on board negative voltage converter to provide the -3.3V for the Tx and Rx op-amps. If required, this can be disabled by fitting a jumper to JP15. In this case, the jumper on JP2 should be moved from pins 1 and 2 to pins 2 and 3, and -6V applied to pin 1 of J26. A separate +3.3V supply is used to power the circuitry on the daughtercard. This is capable of supplying 100mA maximum.

6.1.9 Options

6.1.9.1 External Reference

An external voltage reference (VREF_EXT) can be applied from the RF Transceiver interface. In this case the jumper should be removed from JP13. This will have the effect of centring the *differential Tx I and Q* signals about VREF_EXT.

6.1.9.2 AuxADC Signal Conditioning

AuxADC0, AuxADC1 and AuxADC2 have uncommitted op-amps on their inputs. These op-amps are configured as non-inverting followers by default, but the PCB is arranged so that other configurations are possible by changing component values.

6.2 Firmware Description

There is no firmware required with this Evaluation Kit.

6.3 Software Description

There is no software supplied with this Evaluation Kit. Customers must supply their own software, compatible with their chosen μ Controller.

6.4 Evaluation Tests

This Evaluation Kit is capable of being used to demonstrate the following functions:

- Receive AIS25 and AIS12.5 bursts in AIS burst mode.
- Receive AIS25 and AIS12.5 bursts in AIS raw mode.
- Receive DSC bursts using internal modem.
- Receive DSC bursts using external FX604 modem.
- Transmit AIS25 and AIS12.5 bursts in AIS burst mode.
- Transmit AIS25 and AIS12.5 bursts in AIS raw mode.
- Transmit DSC bursts.
- CS-TDMA sensing and transmit abort.
- Synchronisation to external UTC clock.
- Sleep mode.
- Control of external RF circuitry.
- C-BUS expansion.
- Auxilliary converters.

7. Performance Specification

7.1 Electrical Performance

7.1.1 Absolute Maximum Ratings

Exceeding these maximum ratings can result in damage to the Evaluation Kit.

	Min.	Max.	Units
Supply (+V _{IN} - V _{SS})	-0.3	12.0	V
Supply (-V _{IN} - V _{SS})	+0.3	-12.0	V
Voltage on any connector pin to V _{SS}	-0.3	V _{DD} + 0.3	V
Current into or out of V _{IN} and V _{SS} pins	0	±250	mA
Storage Temperature	-10	+70	°C
Operating Temperature	+10	+35	°C

7.1.2 Operating Limits

Correct operation of the Evaluation Kit outside these limits is not implied.

	Notes	Min.	Max.	Units
Supply (+V _{IN} - V _{SS})		4.5	5.5	V
Supply (-V _{IN} - V _{SS})	1	-6.0	-7.0	V
Operating Temperature		+10	+35	°C

Notes:

1. Negative supply is optional, so this pin may be left unconnected.

7.1.3 Operating Characteristics

For the following conditions unless otherwise specified:

$+V_{IN} - V_{SS} = 5.0V$; External Negative Supply not connected; default jumper positions; $T_{amb} = +25^{\circ}C$; CMX910 Xtal Oscillator Frequency = 19.2MHz.

	Notes	Min.	Typ.	Max.	Units
DC Parameters					
I_{DD} (immediately after power on)			100		mA
I_{DD} (Operating)			160		mA
3V3 External Daughtercard Supply	6	3.15	3.30	3.45	V
AC Parameters					
Tx Single-ended Outputs					
Tx O/P voltage swing			2.0		Vp-p
Tx O/P DC offset	2		0		V
Minimum Load impedance	3		50		Ω
Tx Differential Outputs					
Tx O/P voltage swing	4		2.1		Vp-p
Tx O/P DC offset	5		1.25		V
Minimum Load impedance			2		k Ω
Rx Single-ended Inputs					
Rx I/P max voltage swing			0.85		Vp-p
Rx I/P DC Offset	2		0		V
Input impedance			10		k Ω
Rx Differential Inputs					
Rx I/P max voltage swing			0.85		Vp-p
Rx I/P DC Offset			1.25		V
Input impedance		100			k Ω
FSK Input					
FSK I/P max voltage swing			1.0		Vp-p
FSK I/P DC Offset	2		0		V
Input impedance			10		k Ω

Notes:

2. DC Coupled.
3. These outputs are not designed to drive highly capacitive loads.
4. Peak-to-peak differential i.e. 1.05Vp-p on each pin.
5. Or VREF_EXT. See section 6.1.9.1.
6. This voltage rail is generated by the EV9100 to supply the daughtercard. $I_{out} < 100mA$.

CML does not assume any responsibility for the use of any circuitry described. No IPR or circuit patent licences are implied. CML reserves the right at any time without notice to change the said circuitry and any part of this product specification. Evaluation kits and demonstration boards are supplied for the sole purpose of demonstrating the operation of CML products and are supplied without warranty. They are intended for use in a laboratory environment only and are not for re-sale, end-use or incorporation into other equipments. Operation of these kits and boards outside a laboratory environment is not permitted within the European Community. All software/firmware is supplied "as is" and is without warranty. It forms part of the product supplied and is licensed for use only with this product, for the purpose of demonstrating the operation of CML products. Whilst all reasonable efforts are made to ensure that software/firmware contained in this product is virus free, CML accepts no responsibility whatsoever for any contamination which results from using this product and the onus for checking that the software/firmware is virus free is placed on the purchaser of this evaluation kit or development board.

 CML Microcircuits (UK) Ltd <small>COMMUNICATION SEMICONDUCTORS</small>	 CML Microcircuits (USA) Inc. <small>COMMUNICATION SEMICONDUCTORS</small>	 CML Microcircuits (Singapore) Pte Ltd <small>COMMUNICATION SEMICONDUCTORS</small>
Tel: +44 (0)1621 875500 Fax: +44 (0)1621 875600 Sales: sales@cmlmicro.com Tech Support: techsupport@cmlmicro.com	Tel: +1 336 744 5050 800 638 5577 Fax: +1 336 744 5054 Sales: us.sales@cmlmicro.com Tech Support: us.techsupport@cmlmicro.com	Tel: +65 67450426 Fax: +65 67452917 Sales: sg.sales@cmlmicro.com Tech Support: sg.techsupport@cmlmicro.com
- www.cmlmicro.com -		