

## Features

- For the evaluation of the CMX865 and CMX868A modems
- Target IC Socket for ease of use
- Connectors for convenient connection of external DAA, host micro cards and test-measurement equipments
- Operation with users host controller card or CML PE0001 Interface Card
- Test points for convenient access to most useful signals
- On-board 11.0592MHz Xtal circuit
- On-board 3.3V voltage regulator supplies both analogue and digital rails
- Powered by a single, +5V unregulated supply

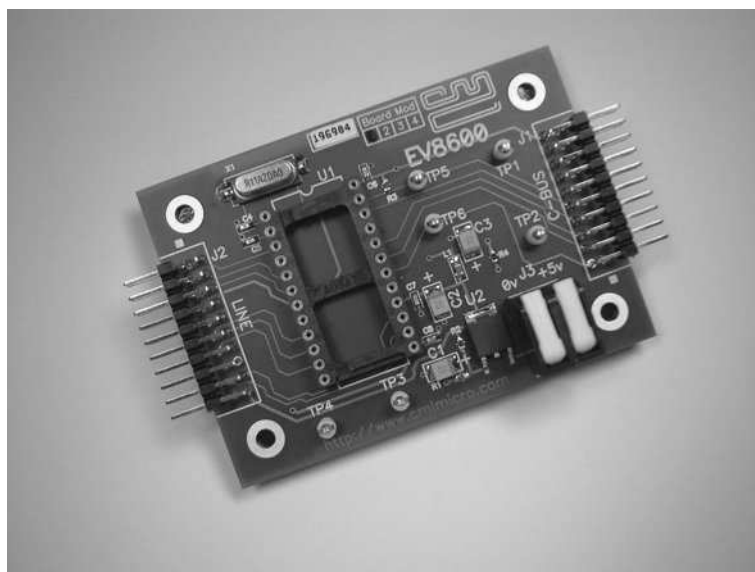

## 1 Brief Description

The EV8600 forms a basic evaluation platform for the CMX865 and CMX868A wireline modems. The board is populated with a dual-in-line socket to host the desired target IC and other components that are common to the two modems.

Two on-board connectors are provided for signal interfacing. The modem connector provides the analogue signal inputs and outputs plus other relevant signals to allow the addition of custom DAAs or to facilitate the connection of telecom test-measurement equipment. The C-BUS connector breaks out the full C-BUS serial interface for convenient connection of a host processor card or the CML PE0001 Evaluation Kit Interface Card.

Continued....

An on-board 3.3 volt filtered and regulated circuit is distributed to analogue and digital rails and is also available at both the modem connector and C-Bus connector for powering off-board circuits.

IC timing is made available by an on-board 11.0592MHz Xtal clock. On-board test-points provide easy access to IRQ and chip select functions as well as both analogue and digital ground points.

The analogue and digital ground planes are physically separate but electrically coupled with a zero-Ohm resistor. This resistor can be removed or replaced with a capacitor if required.

Evaluation ICs are not supplied with this EvKit and should be purchased separately.

<u>Section</u>	<b>CONTENTS</b>	<u>Page</u>
1	<b>Brief Description .....</b>	<b>1</b>
2.	<b>Preliminary Information.....</b>	<b>4</b>
2.1	<b>Laboratory Equipment.....</b>	<b>4</b>
2.2	<b>Handling Precautions .....</b>	<b>4</b>
2.3	<b>Approvals.....</b>	<b>4</b>
3.	<b>Quick Start .....</b>	<b>5</b>
4.	<b>Signal Lists .....</b>	<b>6</b>
5.	<b>Circuit Schematics and Board Layouts .....</b>	<b>8</b>
6.	<b>Detailed Description .....</b>	<b>9</b>
6.1	<b>Hardware Description.....</b>	<b>9</b>
6.2	<b>Adjustments and Controls .....</b>	<b>9</b>
7.	<b>Performance Specification.....</b>	<b>10</b>
7.1	<b>Electrical Performance.....</b>	<b>10</b>

It is always recommended that you check for the latest product datasheet version from the Datasheets page of the CML website: [[www.cmlmicro.com](http://www.cmlmicro.com)].

## **2. Preliminary Information**

### **2.1 Laboratory Equipment**

The following laboratory equipment is needed to use this evaluation kit:

#### **2.1.1 Power Supply**

+5V (nominal), 300mA

### **2.2 Handling Precautions**

Like most evaluation kits, this product is designed for use in laboratory environments. The following practices will help ensure its proper operation.

#### **2.2.1 Static Protection**

This product uses low power CMOS circuits which can be damaged by electrostatic discharge. Partially damaged circuits can function erroneously, leading to misleading results. Observe ESD precautions at all times when handling this product.

#### **2.2.2 Contents - Unpacking**

Please ensure that you have received all of the items on the separate information sheet (EK8600) and notify CML within 7 working days if the delivery is incomplete.

### **2.3 Approvals**

There are no approvals for this product.

### 3. Quick Start

Firstly, a sample of the chosen target device, not supplied, CMX865P4 or CMX868AP4, must be fitted to the socket provided, U1.

An example of how the EV8600 evaluation board may be used in a modem development system is shown below:

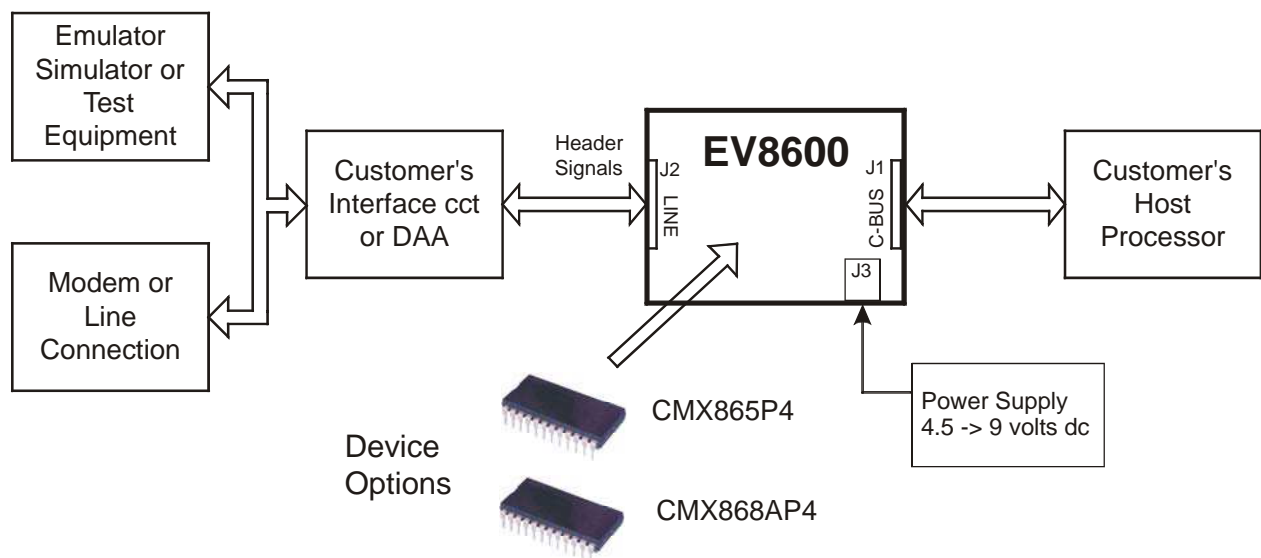

**Figure 1 Modem development using EV8600**

**Care should be taken when connecting the EV8600 to external circuits, as the C-BUS connector (J1) and the line connector (J2) are of the same form factor.**

## 4.

## Signal Lists

CONNECTOR PINOUT				
Connector Ref.	Connector Pin No.	Signal Name	Signal Type	Description
J1	1	-	N/C	
	2	CSN	I/P	C-BUS Chip select. Connects to host $\mu$ C.
	3	-	N/C	
	4	CDATA	I/P	C-BUS Serial data input. Connects to host $\mu$ C.
	5	-	N/C	
	6	SCLK	I/P	C-BUS Serial clock input. Connects to host $\mu$ C.
	7	-	N/C	
	8	RDATA	O/P	C-BUS Serial data output. Connects to host $\mu$ C.
	9	-	N/C	
	10	IRQN	O/P	C-BUS Interrupt request. Connects to host $\mu$ C.
	11, 12	GNDD	PWR	Digital supply ground.
	13, 14, 15, 16, 17, 18	-	N/C	
	19, 20	VDDD	PWR	3.3V dc digital supply rail.
J2	1	-	N/C	
	2	RLYDRV	O/P	Hook switch control.
	3	-	N/C	
	4	RD	I/P	Ring detector input.
	5	VDDD	PWR	3.3V dc digital supply rail.
	6	RT	BI	Ring detector time constant.
	7, 8	GNDD	PWR	Digital supply ground.
	9, 10	GNDA	PWR	Analogue supply ground.
	11	RXAFB	O/P	Receive amplifier feedback.
	12	RXAN	I/P	Receive amplifier inverting input.
	13	RXA	I/P	Receive amplifier non-inverting input.
	14	VBIAS	BI	Analogue bias voltage, 1.65V dc.
	15, 16	GNDA	PWR	Analogue supply ground.

CONNECTOR PINOUT				
Connector Ref.	Connector Pin No.	Signal Name	Signal Type	Description
J2	17	TXAN	O/P	Transmit negative output.
	18	TXA	O/P	Transmit positive output.
	19	-	N/C	
	20	VDDA	PWR	3.3V dc analogue supply rail.
J3	1	+VIN	PWR	External supply voltage.
	2	GNDA	PWR	External supply ground.

TEST POINTS		
Test Point Ref.	Default Measurement	Description
TP1	0V	Digital supply ground.
TP2	0V	Digital supply ground.
TP3	0V	Analogue supply ground.
TP4	0V	Analogue supply ground.
TP5	+3.3V	C-BUS Interrupt output.
TP6	+3.3V	C-BUS Chip Select input.

**Notes:** I/P = Input  
O/P = Output  
BI = Bidirectional  
N/C = Not connected  
PWR = Power supply connection

## 5. Circuit Schematics and Board Layouts

For clarity, circuit schematics are available as separate high resolution files. This can be found on the CML website.

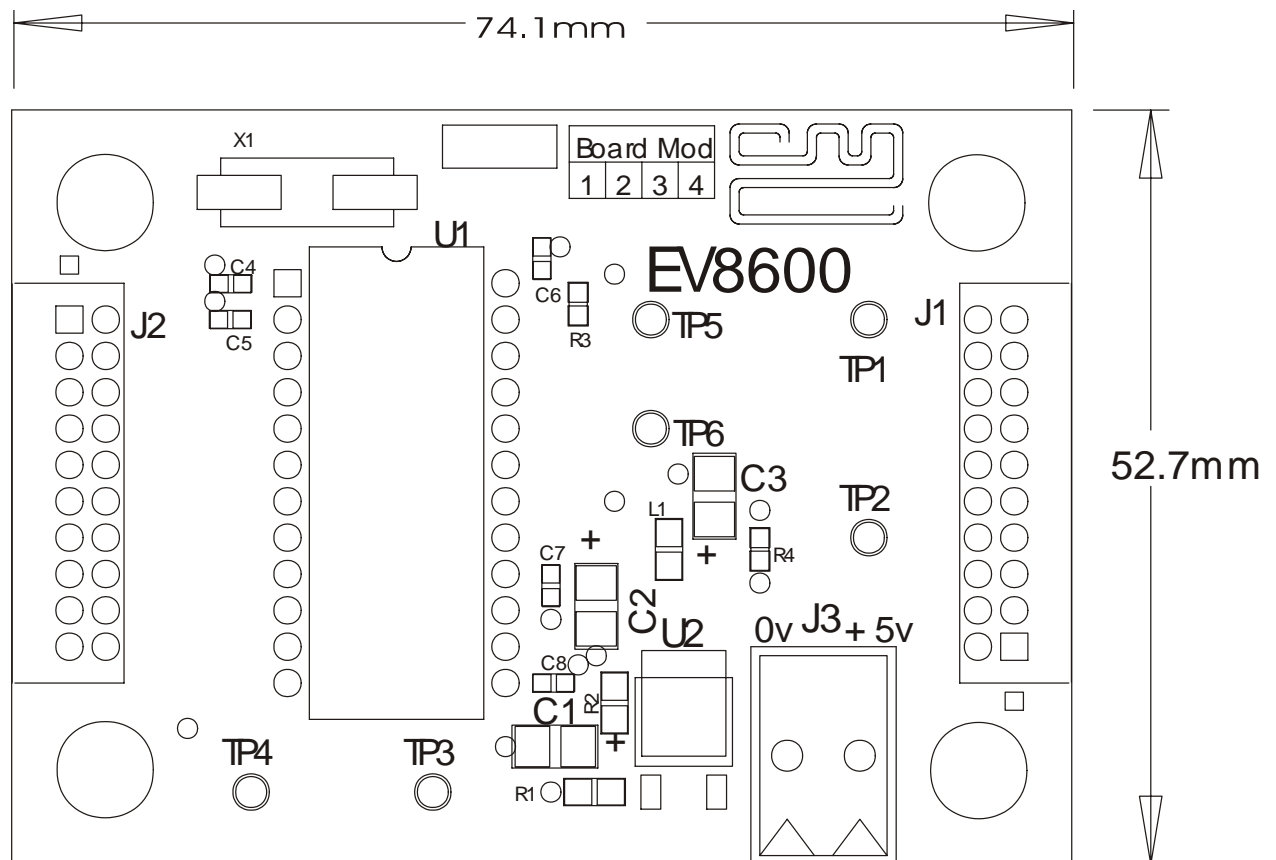

Figure 2 Evaluation Board - Layout

## **6. Detailed Description**

### **6.1 Hardware Description**

#### **6.1.1 Power supply**

The board is fitted with a voltage regulator, U2. The voltage is set to +3.3V dc. Analogue and digital supplies are separated by an inductor, L1. The analogue and digital ground planes are separated by a 0Ω link, R4. There is available current capacity in the regulator to power external circuitry on both the modem and control sides of the board.

#### **6.1.2 Clock/Oscillator**

The CMX86x target device is clocked at a frequency of 11.0592MHz, which is provided by crystal X1.

#### **6.1.3 Modem Interface**

All analogue signals, hook switch control and ring detector input are brought to this connector, J2. In addition both analogue and digital supplies are available for powering external circuitry.

#### **6.1.4 C-BUS interface**

The C-BUS control signals and the C-BUS interrupt request signal are brought to this connector, J1. In addition the digital supply is available for powering external circuitry. This connector is pin compatible with the CML PE0001 evaluation kit interface card.

### **6.2 Adjustments and Controls**

None

## 7. Performance Specification

### 7.1 Electrical Performance

#### 7.1.1 Absolute Maximum Ratings

Exceeding these maximum ratings can result in damage to the Evaluation Kit.

	Min.	Max.	Units
Supply ( $V_{IN} - V_{SS}$ )	-0.3	16.0	V
Voltage on any connector pin to $V_{SS}$	-0.3	$V_{DD} + 0.3$	V
Current into or out of $V_{IN}$ and $V_{SS}$ pins	0	+300	mA
Total current into or out of $V_{DDD}$ and $GND_D$ pins plus $V_{DDA}$ and $GND_A$ pins		+300	mA
Current into or out of any other connector pin	-20	+20	mA

#### 7.1.2 Operating Limits

Correct operation of the Evaluation Kit outside these limits is not implied.

	Notes	Min.	Max.	Units
Supply ( $V_{IN} - V_{SS}$ )		4.5	9.0	V

#### 7.1.3 Operating Characteristics

***Details in this section represent design target values and are not currently guaranteed.***

For the following conditions unless otherwise specified:

Evaluation Device Xtal Frequency = 11.0592MHz,  $V_{IN} = 5.0V$ ,  $T_{amb} = +25^{\circ}C$ .

For CMX86x parameters, see relevant CMX86x data sheet.

	Notes	Min.	Typ.	Max.	Units
<b>DC Parameters</b>					
$V_{DDA}$		3.15	3.3	3.45	V
$V_{DDD}$		3.15	3.3	3.45	V
Current available from $V_{DDD}$ and $V_{DDA}$ combined.			-	300	mA





CML does not assume any responsibility for the use of any circuitry described. No IPR or circuit patent licences are implied. CML reserves the right at any time without notice to change the said circuitry and any part of this product specification. Evaluation kits and demonstration boards are supplied for the sole purpose of demonstrating the operation of CML products and are supplied without warranty. They are intended for use in a laboratory environment only and are not for re-sale, end-use or incorporation into other equipments. Operation of these kits and boards outside a laboratory environment is not permitted within the European Community. All software/firmware is supplied "as is" and is without warranty. It forms part of the product supplied and is licensed for use only with this product, for the purpose of demonstrating the operation of CML products. Whilst all reasonable efforts are made to ensure that software/firmware contained in this product is virus free, CML accepts no responsibility whatsoever for any contamination which results from using this product and the onus for checking that the software/firmware is virus free is placed on the purchaser of this evaluation kit or development board.

**[www.cmlmicro.com](http://www.cmlmicro.com)**

**For FAQs see:** [www.cmlmicro.com/products/faqs/](http://www.cmlmicro.com/products/faqs/)

**For a full data sheet listing see:** [www.cmlmicro.com/products/datasheets/download.htm](http://www.cmlmicro.com/products/datasheets/download.htm)

**For detailed application notes:** [www.cmlmicro.com/products/applications/](http://www.cmlmicro.com/products/applications/)

 <b>CML Microcircuits (UK) Ltd</b> <small>COMMUNICATION SEMICONDUCTORS</small>	 <b>CML Microcircuits (USA) Inc.</b> <small>COMMUNICATION SEMICONDUCTORS</small>	 <b>CML Microcircuits (Singapore) Pte Ltd</b> <small>COMMUNICATION SEMICONDUCTORS</small>	
Oval Park, Langford, Maldon, Essex, CM9 6WG - England.  Tel: +44 (0)1621 875500 Fax: +44 (0)1621 875600  Sales: <a href="mailto:sales@cmlmicro.com">sales@cmlmicro.com</a>  Technical Support: <a href="mailto:techsupport@cmlmicro.com">techsupport@cmlmicro.com</a>	4800 Bethania Station Road, Winston-Salem, NC 27105 - USA.  Tel: +1 336 744 5050, 800 638 5577 Fax: +1 336 744 5054  Sales: <a href="mailto:us.sales@cmlmicro.com">us.sales@cmlmicro.com</a>  Technical Support: <a href="mailto:us.techsupport@cmlmicro.com">us.techsupport@cmlmicro.com</a>	No 2 Kallang Pudding Road, #09 - 05/06 Mactech Industrial Building, Singapore 349307  Tel: +65 6745 0426 Fax: +65 6745 2917  Sales: <a href="mailto:sg.sales@cmlmicro.com">sg.sales@cmlmicro.com</a>  Technical Support: <a href="mailto:sg.techsupport@cmlmicro.com">sg.techsupport@cmlmicro.com</a>	No. 218, Tian Mu Road West, Tower 1, Unit 1008, Shanghai Kerry Everbright City, Zhabei, Shanghai 200070, China.  Tel: +86 21 6317 4107 +86 21 6317 8916 Fax: +86 21 6317 0243  Sales: <a href="mailto:cn.sales@cmlmicro.com.cn">cn.sales@cmlmicro.com.cn</a>  Technical Support: <a href="mailto:sg.techsupport@cmlmicro.com">sg.techsupport@cmlmicro.com</a>