

Features

- **CMX7141 and CMX618 Device Evaluation**
- **Function Image™ load from C-BUS or serial Flash memory**
- **Mic/Speaker/Line Out and Tx/Rx interfaces**
- **Auxiliary ADC and DAC interface**
- **C-BUS interface**
- **Control by PC via a PE0002 interface card or by user's μ Controller.**
- **Interfaces to RF daughterboard with all necessary signals**
- **On-board power regulation and distribution**



1. Brief Description

The DE6181 is designed to assist in the evaluation of the CMX7141 and CMX618 family of products and, when loaded with Function Image™ 7141FI-1.x, can be used to demonstrate a dPMR baseband processor. The kit is in the form of a populated PCB with supporting components to demonstrate the functionality of the CMX618 and CMX7141 ICs. Function Images are available from the CML website for use with the DE6181 for analogue PMR operation and to support a number of digital PMR systems.

The board is fitted with connectors allowing the DE6181 to be controlled by a PE0002 Interface Card and its associated PC GUI software, or by direct connection between the CMX7141 C-BUS serial port and the user's μ C development application or emulation system. The CMX618 is normally controlled via the CMX7141.

On power-up, any suitable CMX7041 or CMX7141 Function Image™ (FI) can be loaded directly into the on-board target CMX7141 IC by using the PE0002 Interface Card or the user's system. Alternatively, the FI can be pre-loaded, separately, into the on-board serial Flash memory, for automatic operation on power-up. In all cases, an Activation Code will need to be supplied by the user before the FI becomes functional. Activation Codes for each FI are available from the CML website.

The DE6181 incorporates all necessary power-supply regulation facilities for operation from a single 5 volt supply, together with a number of board jumpers to enable various circuit arrangements to be effected.

CONTENTS

<u>Section</u>	<u>Page</u>
1. Brief Description	1
2. Preliminary Information	5
2.1. Laboratory Equipment	5
2.2. Handling Precautions	5
2.2.1. Static Protection	5
2.2.2. Contents - Unpacking	5
2.3. Approvals	5
3. Quick Start	6
3.1. With PE0002	6
3.1.1. Setting-Up	6
3.1.2. Operation	7
3.2. Without PE0002	7
4. Signal Lists	8
5. Circuit Schematics and Board Layouts	13
6. Detailed Description	14
6.1. Hardware Description	14
6.1.1. Serial Interfaces	14
6.1.2. CMX7140 Digital Hardware	14
6.1.3. CMX618 Digital Hardware	14
6.1.4. Audio Interfaces	15
6.1.5. Tx/Rx interfaces	16
6.1.6. RF Transceiver interface	16
6.1.7. Power Regulation	17
6.2. Adjustments and Controls	17
6.2.1. DC Offset on Rx inputs	17
6.3. Function Image™	17
6.3.1. Load Function Image™ via C-BUS	18
6.3.2. Load Function Image™ from the serial memory device	19
6.3.3. Program serial memory	20
7. Function Image™ Specific Operation	22
7.1. dPMR Startup Sequence (Tx)	22
7.2. dPMR Startup Sequence (Rx)	22
7.2.1. Connecting and operating two DE6181 units to demonstrate real time dPMR voice	22
7.3. Troubleshooting	22
7.3.1. Modification State	23
8. Performance Specification	24
8.1. Electrical Performance	24
8.1.1. Absolute Maximum Ratings	24
8.1.2. Operating Limits	24
8.1.3. Operating Characteristics	25

<u>Table</u>	<u>Page</u>
Table 1 – Signal List.....	11
Table 2 – Test Loops	11
Table 3 – Test Points	11
Table 4 – Jumpers	12
Table 5 – Adjustments	12
Table 6 – Speaker Output configuration	16
Table 7 – MOD Output characteristics	16
Table 8 – Serial Memory Types	20

<u>Figure</u>	<u>Page</u>
Figure 1 – DE6181 Block Diagram.....	4
Figure 2 – DE6181 used with PE0002	6
Figure 3 – PCB Layout: top	13
Figure 4 - Audio Input Jumper Settings.....	15
Figure 5 – Function Image Load Tab – via C-BUS	18
Figure 6 – Function Image Load Tab – from serial memory.....	19
Figure 7 – Program Serial Memory Tab.....	20
Figure 8 – Thick Stub loaded Message Box	21
Figure 9 – Program Serial Memory complete Message Box.....	21
Figure 10 – Examples of Mod State Identification.....	23

It is always recommended that you check for the latest product datasheet version from the Datasheets page of the CML website: [www.cmlmicro.com].

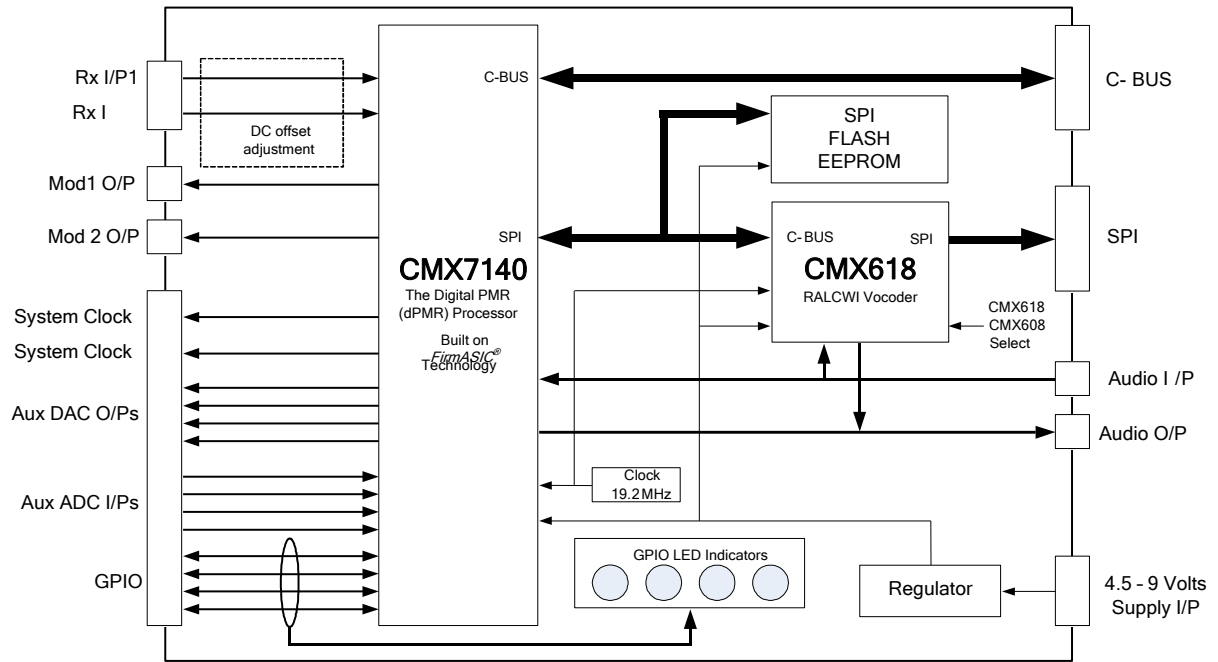

Figure 1 – DE6181 Block Diagram

2. Preliminary Information

This document relates to Revision C of the PCB (pcb #566).

The CMX7140 IC fitted to the DE6181 is a special evaluation IC with the architecture of all CMX704x/CMX714x series ICs: all further references in this document will be to the CMX7140 and apply equally to the CMX7141 target device, apart from the use of different Activation Codes.

The functionality of this CMX7140 evaluation IC is obtained from the relevant Function Image™ (FI); evaluation FIs are downloaded from the CML Technical Portal. Each Function Image™ can represent a different set of features.

2.1. Laboratory Equipment

The following laboratory equipment is needed to use this evaluation kit:

A 5 Volt dc regulated power supply.

If being used with the PE0002 Interface Card the following items will also be required:

1. An IBM compatible PC with the following requirements:
 - One of the following Windows operating systems installed: 2000sp4 or XPsp2.
 - USB port.
 - Minimum screen resolution 800 x 600. Recommended resolution 1024 x 768.
2. Software application ES000221.exe, or later version, installed on the PC.
3. A USB type A male to mini B male cable.

Although the PE0001 is no longer available, existing users of this Interface Card can still use it to control the DE6181. When used with the PE0001 the following items will also be required:

1. An IBM compatible PC equipped with a serial port and with one of the following Microsoft operating systems installed - 98, NT, 2000sp4 or XP.
2. Software application ES000123.exe, or later version, installed on the PC.
3. RS232, 9-way DTE <-> DCE cable.

2.2. Handling Precautions

Like most evaluation kits, this product is designed for use in office and laboratory environments. The following practices will help ensure its proper operation.

2.2.1. Static Protection

This product uses low power CMOS circuits that can be damaged by electrostatic discharge. Partially damaged circuits can function erroneously, leading to misleading results. Observe ESD precautions at all times when handling this product.

2.2.2. Contents - Unpacking

Please ensure that you have received all of the items on the separate information sheet (EK6181) and notify CML within 7 working days if the delivery is incomplete.

2.3. Approvals

This product is not approved to any EMC or other regulatory standard.

3. Quick Start

This section is divided into two sub-sections. The first is for those users who are using the DE6181 with a PE0002 Interface Card and its Windows PC application. The second is for users who are using the DE6181 with another host controller. Users wishing to control the DE6181 from a PE0001 Interface Card should contact CML Technical Support at techsupport@cmlmicro.com, if further assistance is required, as the PE0001 Interface Card is no longer available.

3.1. With PE0002

3.1.1. Setting-Up

The PE0002 driver and software must be installed by following the instructions given in the PE0002 User Manual.

On the DE6181/PE0002:

- Connect J5 of the PE0002 Interface Card to J15 of the DE6181 board.
- Ensure that all pins of DE6181 header J40 are open circuit. (By default, the jumpers are fitted to J40, which is the correct configuration if the DE6181 is used with a user-supplied host controller card, rather than a PE0002).
- Connect a 5V regulated DC supply to J8 on the PE0002 Interface Card.
- Connect 5V power by linking J25 on the DE6181 board with J10 on the PE0002 Interface Card.
- Ensure that J2 on the PE0002 Interface Card is connected to a PC with a USB cable.
- Turn on the power supply. The power-on indicator D6 will light on the DE6181 board.
- Press the reset switch (SW1) on the PE0002 Interface Card, if requested.

The basic arrangement, when used with the PE0002 is shown below.

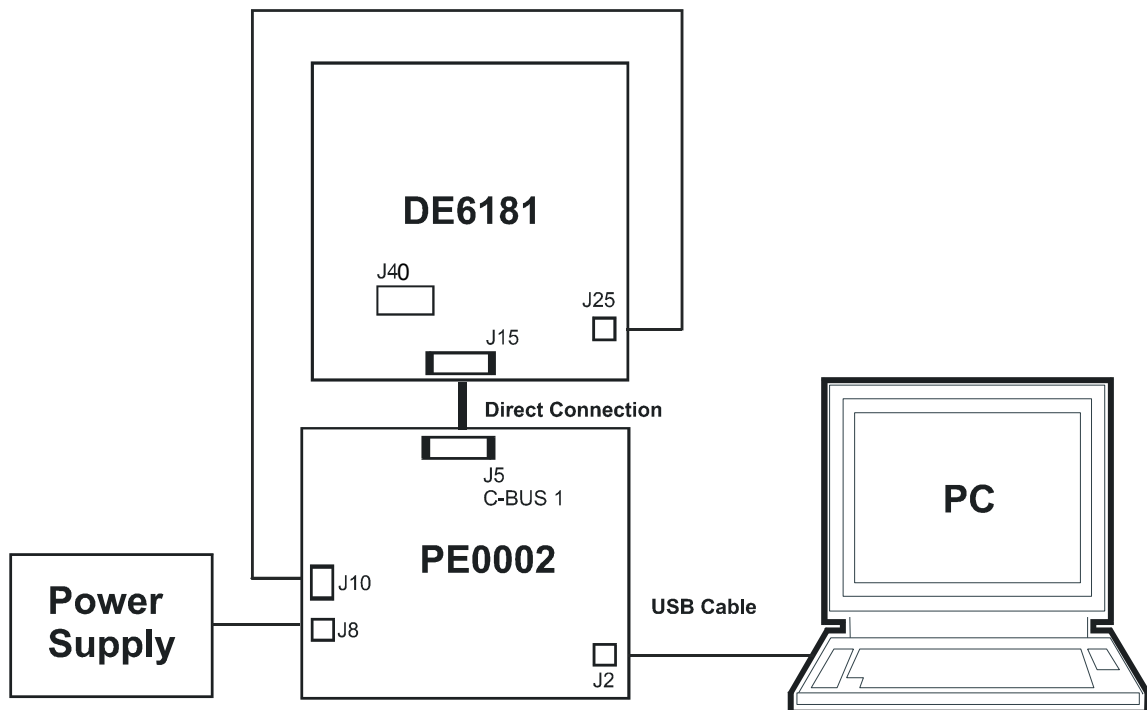

Figure 2 – DE6181 used with PE0002

3.1.2. Operation

The Function Image™ (FI) must now be downloaded into the CMX7140. Use the 'Function Image Load' tab of the PE0002 windows application.

The DE6181 is now ready to use in the evaluation of CMX7140, with the chosen FI, and the CMX618.

3.2. Without PE0002

As an alternative to using the PE0002 Interface Card, users may control the CMX7140 on the DE6181 kit with a user-supplied host controller card. C-BUS serial interface connections are made via connector J15. The CMX618 is normally controlled via the CMX7140.

The power-up, or boot state, of the CMX7140 may be set by using jumpers on header J40. Consult the relevant Function Image™ documentation for valid modes. Fitting a jumper pulls the pin high. The chosen FI can then be downloaded to the CMX7140, via C-BUS, on power-up.

Both the DE6181 and the user-supplied host controller card should be powered-up together. If the jumpers on header J40 are omitted, the user must ensure that the BOOTEN1 and BOOTEN2 pins of the CMX7140 are in their intended state within 1.6ms of applying power to the DE6181.

4. Signal Lists

CONNECTOR PINOUT				
Connector Ref.	Connector Pin No.	Signal Name	Signal Type	Description
POWER				
J25	1	-VIN	I/P	Negative power. -6V Nominal
J25	2	GNDD	GND	Digital Ground
J25	3	+VIN	I/P	Positive Power. +5V Nominal
CBUS				
J15	1	HOST_CSN_2	I/P	C-BUS Chip Select from host
J15	2	HOST_CSN_1	I/P	C-BUS Chip Select from host
J15	3	RF_CS	I/P	RF Serial Chip Select from host
J15	4	HOST_CDATA	I/P	C-BUS Command data from host
J15	5	RF_MOSI	I/P	RF Serial Data from host
J15	6	HOST_C-BUS_SCLK	I/P	C-BUS SCLK from host
J15	7	RF_SCLK	I/P	RF Serial chip select from host
J15	8	HOST_RDATA	O/P	C-BUS Reply data from host
J15	9	IRQN_6x8	O/P	Open-drain IRQN from CMX618
J15	10	IRQN_7140	O/P	Open-drain IRQN from CMX7140
J15	11	GNDD	GND	Digital Ground
J15	12	GNDD	GND	Digital Ground
J15	13	BOOTEN1	I/P	CMX7140 Boot mode selection
J15	14	BOOTEN2	I/P	CMX7140 Boot mode selection
J15	15	TP28	N/A	Testpoint
J15	16	TP40	N/A	Testpoint
J15	17	TP41	N/A	Testpoint
J15	18	TP42	N/A	Testpoint
J15	19	+3V3D	O/P	+3.3V Regulated power
J15	20	+3V3D	O/P	+3.3V Regulated power

CONNECTOR PINOUT				
Connector Ref.	Connector Pin No.	Signal Name	Signal Type	Description
EXTERNAL CODEC (SPI ON DE6180)				
J12	1	6x8_SPARE	N/A	Spare
J12	2	+3V3D	O/P	+3.3V Regulated power
J12	3	6x8_SSIN	I/P	Slave Select In
J12	4	6x8_MOSI	I/P	Master Out Slave In
J12	5	GNDD	GND	Digital Ground
J12	6	6x8_SPI_SCLK	I/P	Bitclock
J12	7	EEC	O/P	Enable External Codec
J12	8	6x8_MISO	O/P	Master In Slave Out
J12	9	REC	O/P	Reset External Codec
J12	10	CSEL	I/P	Codec Select
RF. Note that J10 is numbered 1-30 along one edge, then 31-60 in the opposite direction along the other edge.				
J10	1	RF_MOSI	O/P	Master Out - Slave In for RF serial interface
J10	2	RF_SCLK	O/P	Bitclock for RF serial interface
J10	3	TP37	N/A	Testpoint
J10	4	TP38	N/A	Testpoint
J10	5	GNDD	GND	Digital Ground
J10	6	GPIO1	BI	CMX7140 GPIO 1
J10	7	GPIOA	BI	CMX7140 GPIO A
J10	8	GNDD	GND	Digital Ground
J10	9	SYSCLK1	O/P	CMX7140 Sysclock 1 output
J10	10	GNDD	GND	Digital Ground
J10	11	+3V3EXT	O/P	+3.3V regulated power
J10	12	+VIN_FILT	O/P	+5V (nominal) unregulated power
J10	13	+VIN_FILT	O/P	+5V (nominal) unregulated power
J10	14	GNDA	GND	Analogue Ground
J10	15	19M2_TCXO_RF	O/P	Buffered 19.2MHz VCTCXO output
J10	16	AUXDAC1	O/P	CMX7140 DAC 1
J10	17	AUXDAC3	O/P	CMX7140 DAC 3
J10	18	GNDA	GND	Analogue Ground
J10	19	AUXADC4	I/P	CMX7140 ADC 4
J10	20	AUXADC2	I/P	CMX7140 ADC 2

CONNECTOR PINOUT				
Connector Ref.	Connector Pin No.	Signal Name	Signal Type	Description
J10	21	GNDA	GND	Analogue Ground
J10	22	DISC_IN	I/P	CMX7140 Discriminator i/p, via op-amp cct.
J10	23	ALT_IN	I/P	CMX7140 Alternative i/p, via op-amp cct.
J10	24	VBIAS	O/P	Buffered CMX7140 Vbias (1.65V Nominal)
J10	25	MOD1	O/P	Buffered CMX7140 MOD1 output
J10	26	MOD2	O/P	Buffered CMX7140 MOD2 output
J10	27	VBIAS	O/P	Buffered CMX7140 Vbias (1.65V Nominal)
J10	28	-VIN	O/P	-6V (nominal) unregulated power
J10	29	TP25	N/A	Testpoint
J10	30	TP23	N/A	Testpoint
J10	31	TP27	N/A	Testpoint
J10	32	TP26	N/A	Testpoint
J10	33	TP24	N/A	Testpoint
J10	34	GNDA	GND	Analogue Ground
J10	35	GNDA	GND	Analogue Ground
J10	36	GNDA	GND	Analogue Ground
J10	37	GNDA	GND	Analogue Ground
J10	38	N/C	N/A	
J10	39	N/C	N/A	
J10	40	GNDA	GND	Analogue Ground
J10	41	AUXADC1	I/P	CMX7140 ADC 1
J10	42	AUXADC3	I/P	CMX7140 ADC 3
J10	43	GNDA	GND	Analogue Ground
J10	44	AUXDAC4	O/P	CMX7140 DAC 4
J10	45	AUXDAC2	O/P	CMX7140 DAC 2
J10	46	GNDA	GND	Analogue Ground
J10	47	GNDA	GND	Analogue Ground
J10	48	GNDA	GND	Analogue Ground
J10	49	+VIN_FILT	O/P	+5V (nominal) unregulated power
J10	50	+3V3EXT	O/P	+3.3V regulated power
J10	51	GNDD	GND	Digital Ground
J10	52	SYSCLK2	O/P	CMX7140 Sysclock 2 output

CONNECTOR PINOUT				
Connector Ref.	Connector Pin No.	Signal Name	Signal Type	Description
J10	53	GNDD	GND	Digital Ground
J10	54	GPIOB	BI	CMX7140 GPIO B
J10	55	GPIO2	BI	CMX7140 GPIO 2
J10	56	GNDD	GND	Digital Ground
J10	57	IRQN_7140	O/P	CMX7140 IRQN output (open drain)
J10	58	TP29	N/A	Testpoint
J10	59	RF_nCS	O/P	Chip Select for RF Serial interface
J10	60	TP39	N/A	Testpoint

Table 1 – Signal List

TEST LOOPS		
Test Loop Ref.	Default Measurement	Description
TP15, 16	0V	Digital Ground
TP17, 18	0V	Analogue Ground
TP2	N/A	CMX7140 GPIO B
TP3	N/A	CMX7140 GPIO A
TP4	N/A	CMX7140 GPIO 2
TP5	N/A	CMX7140 GPIO 1
TP10	N/A	CMX6x8 EEC
TP11	N/A	CMX6x8 REC
TP12	N/A	CMX6x8 Spare

Table 2 – Test Loops

TEST POINTS		
Test Point Ref.	Default Measurement	Description
TP14	+3.3V	+3.3V Digital Supply
TP19	+1.8V	+1.8V Digital Supply
TP20	+3.3V	+3.3V Analogue Supply
TP21	+3.3V	+3.3V External Supply
TP22	-3.3V	-3.3V Analogue Supply

Table 3 – Test Points

JUMPERS			
Link Ref.	Positions	Default Position	Description
J7	1-2, 3-4	3-4	CMX7140 Clock source. 1-2 is crystal, 3-4 is VCTCXO
J40	1-2, 3-4	1-2 and 3-4	CMX7140 Boot mode. See Function Image™ documentation
JP2	1-2	NF	Serial Flash Memory Write Protect. NF is protected
J6	1-2, 3-4, 5-6, 7-8	NF	CMX7140 GPIO pins. Fitting jumper pulls pin down to 0V
J9	1-2, 3-4	3-4	CMX618 Clock source. 1-2 is crystal, 3-4 is VCTCXO
J13	1-2, 3-4, 5-6	3-4	CMX618 Clock Frequency. 1-2 is XTALSEL1, 3-4 is XTALSEL2, 5-6 is XTALSEL3. Fitting the jumper pulls the pin low
JP5	1-2	NF	CMX618 ENABXTAL. Fitting the jumper pulls the pin low
JP4	1-2	NF	If fitted, this jumper connects SYNC on the CMX618 to GPIOA on the CMX7140
JP7	1-2	NF	If fitted this jumper connects the IRQN lines of the CMX618 and CMX7140 together
J18, J26		J18: 3-4	See section 6.1.4 Audio Interfaces
J1		3-4, 6-8 and 9-11	See section 6.1.4 Audio Interfaces
JP1	1-2, 2-3	2-3	See section 6.1.4 Audio Interfaces
JP11	1-2, 2-3	1-2	See section 6.1.4 Audio Interfaces
JP18	1-2	1-2	See section 6.1.4 Audio Interfaces
JP19	1-2	1-2	See section 6.1.4 Audio Interfaces
J8, J20, J30, J31	1-2, 2-3, 3-4	2-3	These 4 connectors control the routing for the serial interfaces. All 4 connectors must have the same arrangement. 1-2 connects the host C-BUS to the CMX6x8 C-BUS. 2-3 connects the CMX6x8 C-BUS to the CMX7140 C-BUS. 3-4 connects the CMX7140 SPI to the CMX6x8 SPI

Table 4 – Jumpers

ADJUSTMENTS			
Adjustment Ref.	Adjustment	Adjustment Range	Description
VR1		0.77 – 2.53V	DC Offset for CMX7140 Disc input
VR2		0.77 – 2.53V	DC Offset for CMX7140 Alt input

Table 5 – Adjustments

Notes:	I/P = Input	TL = Test Loop
	O/P = Output	TP = Test Point
	BI = Bidirectional	

6. Detailed Description

6.1. Hardware Description

The DE6181 hardware comprises a CMX7140 and a CMX618, together with circuitry to allow demonstration and evaluation of the features of both devices, particularly working together to form the basis of the baseband section of a dPMR radio.

6.1.1. Serial Interfaces

The CMX7140 and CMX618 both have C-BUS slave interfaces. The CMX618 has an SPI slave interface. The CMX7140 has an SPI master/slave interface.

The CMX7140 C-BUS slave interface is connected to J15, which can be driven directly by a PE0002 or other host controller. The signal on pin 2 is used as the chip select.

The CMX618 SPI slave interface is connected to J12. This is intended for connection of an external codec, if the CMX618 is configured for this mode of operation.

The jumper field made from J8, J20, J30 and J31 can be used to configure the other serial interface connections. The default state is for each connector to have a jumper fitted across pins 2 and 3. This connects the CMX7140 SPI interface to the CMX618 C-BUS interface. This type of connection is supported by the 7141FI-1.x, which passes vocoder data over this link and also has a pass-through mode to allow host configuration of the CMX618.

Alternatively, jumpers can be fitted across pins 1 and 2 of each connector. This connects the CMX618 C-BUS interface to J15, but using pin 1 as the chip select. This allows the host direct access to the CMX618 and the CMX7140 via the same C-BUS port. It also allows the PE0002 to separately control the CMX618 using the script command "Device 2". R11 must be removed and R12 fitted on the PE0002 to use this feature.

Additionally, jumpers can be fitted across pins 3 and 4 of each connector. This connects the CMX7140 SPI master interface to the CMX618 SPI slave interface. There are currently no FIs which support this connection scheme.

The CMX7140 SPI interface is also used for booting from serial Flash memory, using EPCSN as the chip select rather than SSOUT. This operation will work with any jumper configuration.

6.1.2. CMX7140 Digital Hardware

The BOOTEN1 and BOOTEN2 signals have pull down resistors, so will normally be low. Fitting a jumper across pins 1 and 2 of J4 will set BOOTEN1 high. Fitting a jumper across pins 3 and 4 of J4 will set BOOTEN2 high. If jumpers are not fitted, then both signals can be driven high from the PE0002 or other host controller via J15. Note that the levels on the BOOTENx pins must be valid at reset or within 1.6ms of applying power to the DE6181.

The GPIO pins are available on J6 and TP2-TP5. They can also be monitored using LEDs D1-D4.

The CMX7140 can be clocked from either a 19.2MHz VCTCXO (default jumper connection) or an oscillator constructed around the HC49 crystal X1, which is not fitted by default. In order to use this oscillator, a suitable crystal, load capacitors (C22, C23) and feedback resistor (R37) should be fitted, and the pulldown (R22) removed. Fitting a jumper across J7 pins 1 and 2 will select the crystal. Fitting a jumper across pins 3 and 4 will select the VCTCXO.

6.1.3. CMX618 Digital Hardware

The CMX618 has access to the same clock sources as the CMX7140 (see above). Fitting a jumper across J9 pins 1 and 2 will select the crystal. Fitting a jumper across pins 3 and 4 will select the VCTCXO. J13 and JP5 can be used to set up the CMX618's clock options. Details are given in Table 4 – Jumpers.

The CMX618's SYNC pin is connected to GPIOA on the CMX7140 via JP4.

6.1.4. Audio Interfaces

All Audio Interface connectors can be configured to support different types of signal connections and a variety of external equipment such as SoundBlaster™ compatible headsets and PC-based soundcards. Each connector has an optional ground connection to avoid ground loops via external connections.

The Mic/Line In interface is a 3.5mm jack socket J14 connected to both the CMX618 Microphone inputs INPUTP and INPUTN and the CMX7140 Mic input, via a configurable jumper field J1. See below for how to configure for a single ended or differential input.

DC bias is provided for an electret microphone. This can be selected as 3.3V (fit JP11 2-3) or VIN_FILT (the external supply to the board - fit JP11 1-2), or disabled (remove jumpers from JP11).

Signal level and gain settings should be selected to ensure the signal level at all stages in the signal processing chain is kept within the recommended limits.

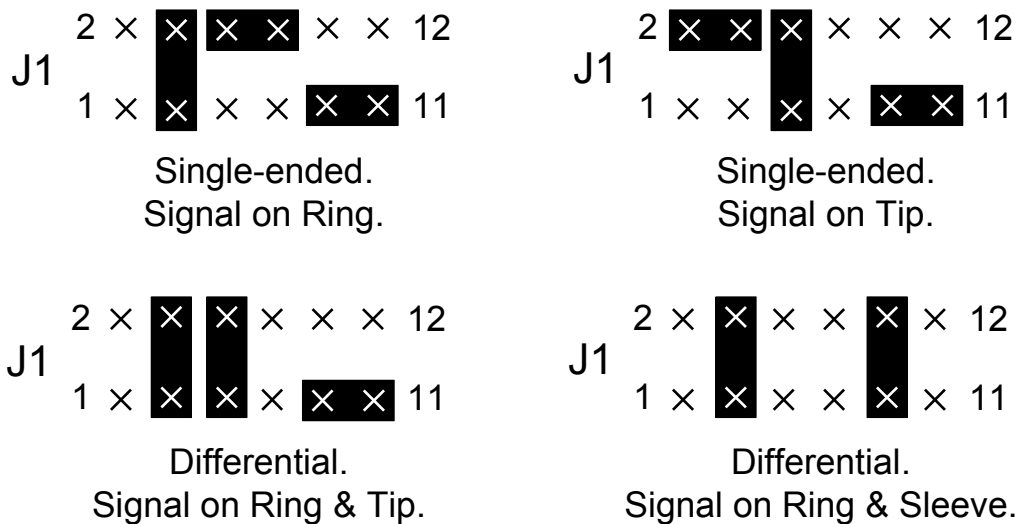

Figure 4 – Audio Input Jumper Settings

The Line out interface is a 3.5mm jack socket J16 connected to either the CMX618 audio output or the CMX7140 audio output. Fit JP1 1-2 to select CMX7140, or JP1 2-3 to select CMX618. The selected output is connected to the tip of J16. If JP19 is fitted, the signal is also connected to the ring. The sleeve of J16 may optionally be connected to the analogue ground of the PCB by fitting JP18.

The Speaker output is a 3.5mm jack socket connected to the CMX618 audio outputs via jumper fields J18 and J26. The following table details how to configure these jumpers to obtain different output configurations.

Configuration Description	J18 Jumper Position	J26 Jumper Position
Stereo 8 ohm Speakers, configured as 16 ohm Load, Differential Drive, Opposite Phase (L/R)	3 - 4	Open
Stereo 8 ohm Speakers, OutP Left OutN Right, Single End Drive, Opposite Phase (L/R)	3 - 4	1 - 2
Stereo High Impedance (Amplified) Speakers, OutP Left OutN Right, Single End Drive, Opposite Phase (L/R)	3 - 4	5 - 6
Mono Speaker, Single End Drive	Open	1 - 2
Mono Speaker, Differential Drive	Open	3 - 4
Stereo Headphones 32 ohms, Single End Drive, Opposite Phase (L/R)	3 - 4	1 - 2
Stereo Headphones 32 ohms, 16 ohm load, Single End Drive, Same Phase (L/R)	1 - 2	1 - 2

Table 6 – Speaker Output Configuration

6.1.5. Tx/Rx Interfaces

Baseband Rx signals can be applied to the SMA connectors J17 and J19. These signals pass through op-amp circuits to provide gain, level shifting and variable DC offset before driving the CMX7140's Disc and Alt inputs. The inputs to the op-amp circuits are DC coupled and single-ended.

Baseband Tx signals can be taken from SMA connectors J21, J22, J23 and J24. Table 7 shows the characteristics of each output.

Connector	Signal	DC Level	50Ω Drive
J21	MOD1 (Inverted)	1.65V	NO
J22	MOD1	0V	YES
J23	MOD2 (Inverted)	1.65V	NO
J24	MOD2	0V	YES

Table 7 – MOD Output Characteristics

Note that the circuitry which provides the 0V centred, 50Ω drive outputs (U16, U17 and associated components) is not fitted in the standard build. If fitted by the user, this circuitry will require an external negative power supply to be connected to J25.

6.1.6. RF Transceiver Interface

The RF Transceiver interface is a 60-way right-angled connector with all of the following signals:

- Serial interface (from J15 – separate from C-BUS interface)
- CMX7140 GPIO
- CMX7140 SYSCLOCK outputs
- 3.3V Power (output from this card capable of supplying 100mA)
- 5V and -6V Power (direct from PCB input supply - unregulated)
- 19.2MHz VCTCXO output (buffered)
- DISC, ALT, MOD1, MOD2 (all buffered)
- All ADCs and DACs

- VBIAS reference voltage
- Digital and Analogue Grounds

The connector is made by JAE and is part number TX24-60R-LT-H1E. The mating half is part number TX25-60P-LT-XXX. Both parts are available in the UK from Digi-Key.

6.1.7. Power Regulation

Power is applied to J25. Nominal voltages are +5V and –6V. The –6V supply is only needed for the optional 50Ω output buffers. If these buffers are not used then the pin on J25 can be left open-circuit. The PCB is protected against over-voltage and reverse voltage. Separate regulators are provided for +3.3V Digital and Analogue, +1.8V Digital and –3.3V Analogue supplies.

6.2. Adjustments and Controls

6.2.1. DC Offset on Rx Inputs

VR1 and VR2 can be used to adjust the DC offset applied to the Disc and Alt inputs.

6.3. Function Image™

Whenever power is removed from the DE6181, the FI data will be erased from the CMX7140 device. Therefore, whenever power is applied a FI must be loaded, either from the serial memory or via the C-BUS interface.

There are two methods by which a FI may be loaded into the CMX7140 device.

If the DE6181 is used with the PE0002 Evaluation Kit Interface Card, function images can be loaded as follows:

6.3.1. Load Function Image™ via C-BUS

Use the Function Image Load tab. Select Function Image Source: "C-BUS".

- Enter the name of the file containing the Function Image™, or navigate to the required file using the 'Browse' button.
- Enter the activation code in the lower edit box. Alternatively select one of two previously used codes in the drop down list.
- Select Target Board.
- Click the 'Load' button. The progress of the download is shown visually on the progress bar and when the download has completed a message box will be displayed indicating if the result of the download operation was successful or not.

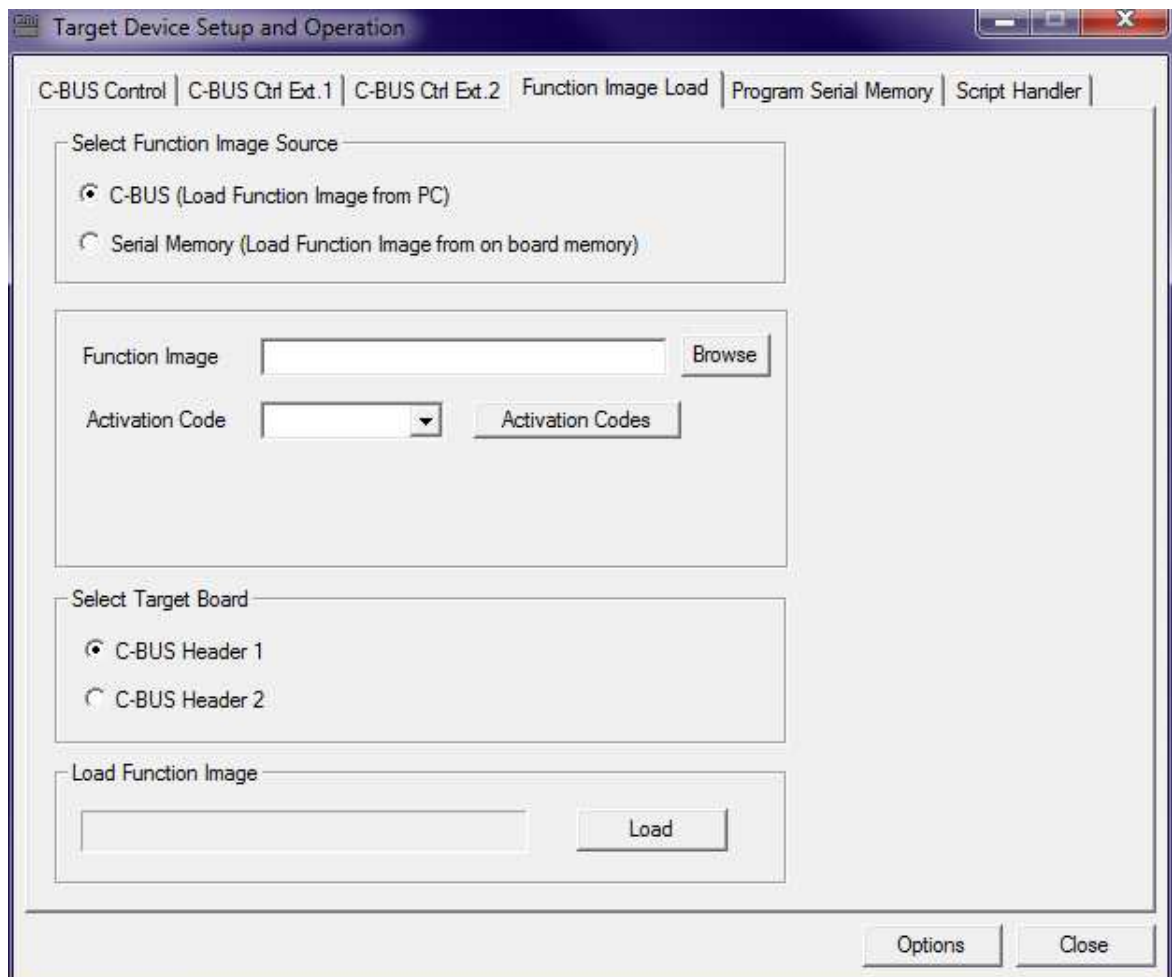

Figure 5 – Function Image Load Tab – via C-BUS

6.3.2. Load Function Image™ from the Serial Memory Device

It is assumed that the serial memory has been programmed with the Function Image™ prior to using this load method. This can be carried out with the serial memory in circuit using the ES0002xx 'Program Serial Memory' tab.

Use the Function Image Load tab. Select Function Image Source: "Serial Memory".

- Enter the activation code in the lower edit box. Alternatively select the activation code from the drop-down list or from the Activation Codes dialogue.
- Select Target Board.
- Click the 'Load' button. The progress of the download is shown visually on the progress bar and when the download has completed a message box will be displayed indicating if the result of the download operation was successful or not.

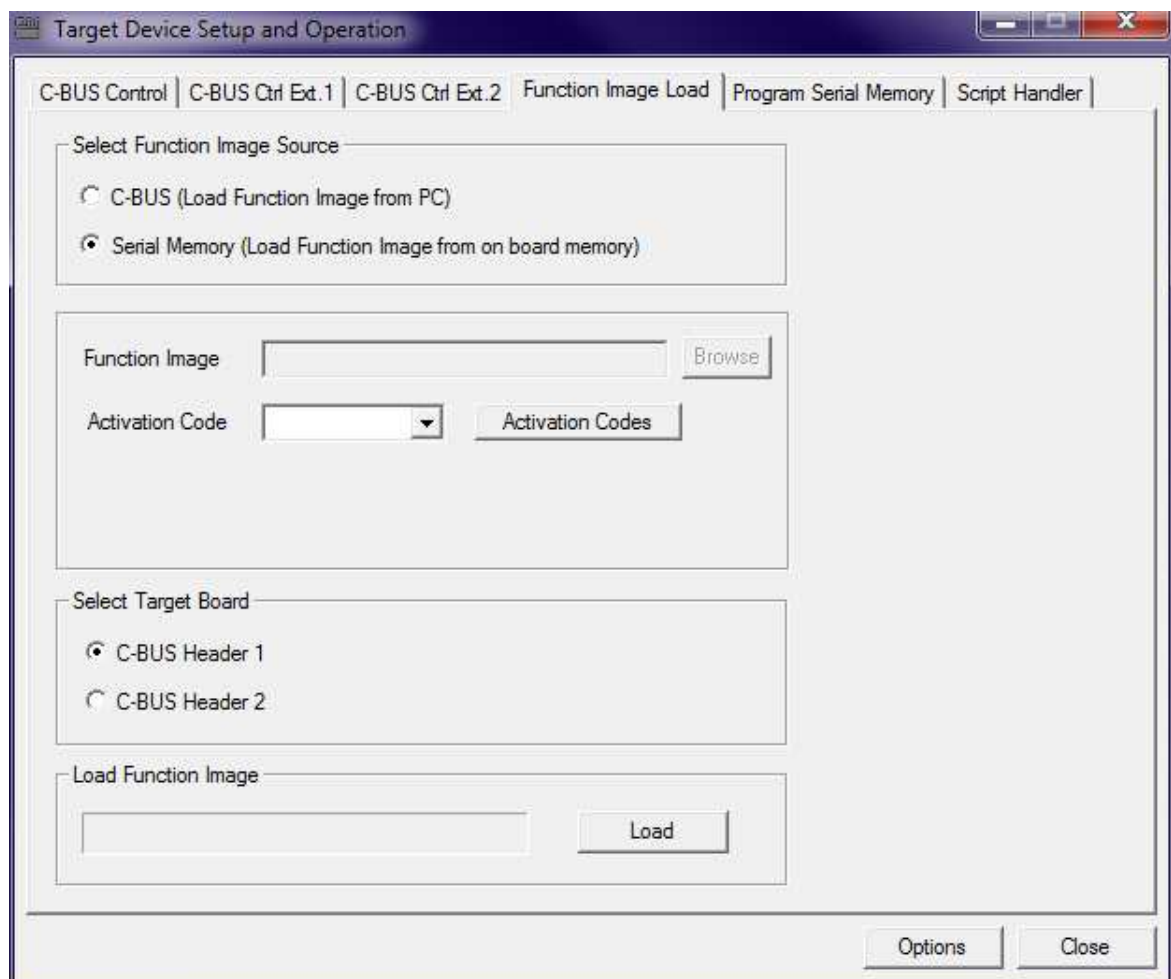

Figure 6 – Function Image Load Tab – from Serial Memory

6.3.3. Program Serial Memory

The specific serial memory device fitted to the DE6181 and the appropriate "thick stub" application software are shown below. The "thick stub" application software is included in the DE6181 support files.

Revision	Serial numbers	Memory type	Thick Stub
Up to Rev B Mod 3*	Up to 199366	Atmel AT25F512A	FI_FLASH_xx.h
Rev B Mod 4*		ST M25P10A or equivalent.	EF0402_M25P10A_xx.h
From Rev C		ST M25P10A or equivalent.	EF0402_M25P10A_xx.h

Table 8 – Serial Memory Types

* For correct identification of mod state (modification state) see section 7.3.1

Use the 'Program Serial Memory' tab:

- Enter the name of the file containing the thick stub, or navigate to the required file using the 'Browse' button. This file is in the same 'C' language header format as the Function Image™.
- Enter the name of the file containing the Function Image™, or navigate to the required file using the 'Browse' button.
- Enter, in units of MHz, the crystal/clock input frequency of the CMX7140 device, see section 6.1.2. The default is 19.2MHz. The Clk. Divide Setting is dependent on the entered frequency value and is calculated by the software, requiring no intervention from the user.
- Select Target Board.
- Click the 'Load' button.

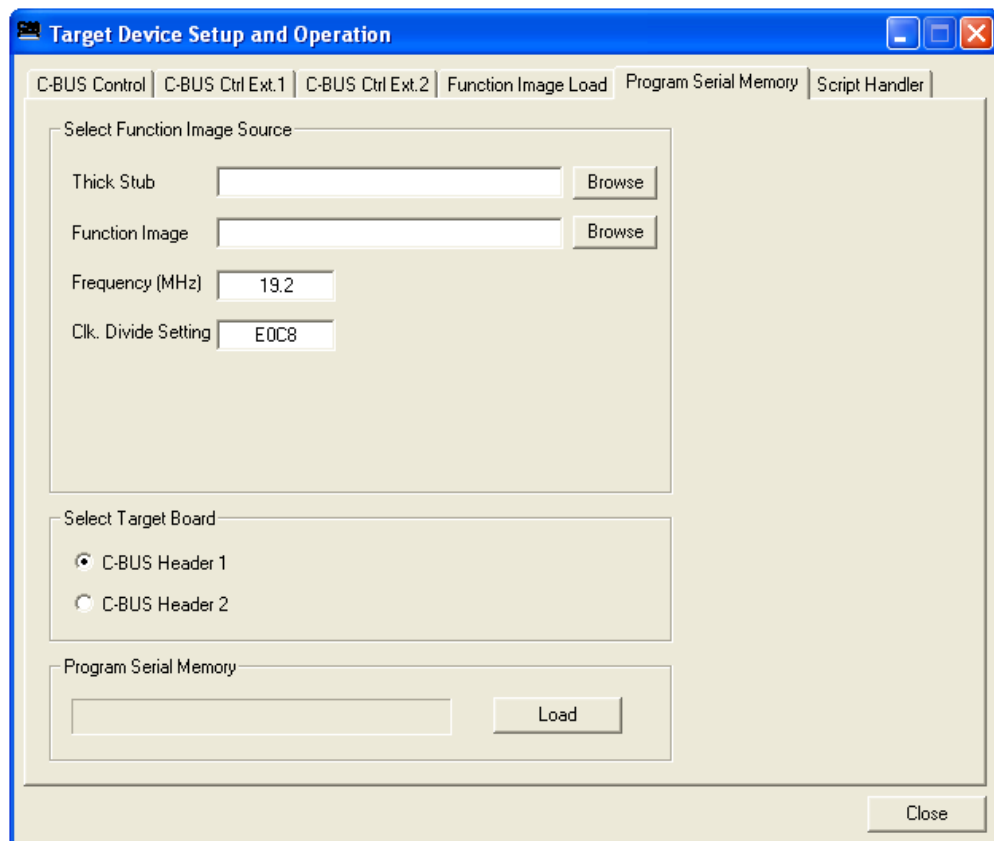

Figure 7 – Program Serial Memory Tab

Shortly after pressing the 'Load' button, a message box will confirm that the application has loaded the Thick Stub.



Figure 8 – “Thick Stub loaded” Message Box

Click on the message box 'OK' button and the application will proceed to programme the Function Image™ into the serial memory on the DE6181 card. Progress is shown visually on the progress bar. When programming is complete a message box will be displayed indicating if the operation was successful or not.



Figure 9 – “Program Serial Memory complete” Message Box

7. Function Image™ Specific Operation

7.1. dPMR Startup Sequence (Tx)

- Load 7141FI-1.x into the CMX7140 and enter the activation code.
- Wait for the PRG bit to go high (bit 0 in Status register (\$C6)).
- Turn on all analogue hardware (\$C0 = \$FFC0)
- Set up Analogue Routing and Gain (\$B1 = \$0290, \$B0 = \$7700)
- Set the vocoder input gain (write e.g. \$0040 to \$C3).
- Load the five TxData registers with suitable header data.
(e.g. \$B5 = \$1009 ; \$B6 = \$0000 ; \$B7 = \$1001 ; \$CA = \$0FFF ; \$CB = \$001F)
- Set Tx Burst mode (write \$0012 to \$C1).

The DE6181 will then transmit the header, followed by dPMR formatted frames consisting of data produced by the CMX618 vocoder. To end the transmission:

- Ensure that the DataTransfer bit is clear (bit 5 in Status register (\$C6)).
- Load TxData0 and TxData1 with suitable end data. (e.g. \$B5 = \$AB72 ; \$B6 = \$0012)
- Clear the TxBurst mode bit (write \$0002 to \$C1).

The DE6181 will then finish transmitting the current data frame and transmit the end frame.

7.2. dPMR Startup Sequence (Rx)

- Load 7141FI-1.x into the CMX7140 and enter the activation code.
- Wait for the PRG bit to go high (bit 0 in Status register (\$C6)).
- Turn on all analogue hardware (\$C0 = \$FFC0)
- Set up Analogue Routing and Gain (\$B1 = \$0290, \$B0 = \$7700)
- Set the vocoder output gain (write e.g. \$0004 to \$C3).
- Set Rx Burst mode (write \$0011 to \$C1).

The CMX7140 will then wait for a header to be received, and then receive dPMR formatted frames and pass the payload data to the CMX618 vocoder. If a valid end frame is received, the CMX7140 will return to waiting for a header.

7.2.1. Connecting and operating two DE6181 units to demonstrate real time dPMR voice

- Power up both DE6181 PCBs, and connect each to a C-BUS master (host controller card).
- Connect J21 (Mod1) on the Tx board to J17 (Disc) on the Rx board.
- Ensure all jumper settings match the defaults described in Table 4.
- Attach a microphone or audio source to J14 (Mic) on the Tx board and speakers to J11 (Line Out) or J16 (Speaker) on the Rx board.
- Set up the Rx board as described in section 7.2
- Set up the Tx board as described in section 7.1.
- Check the signal at pin 1 of U12, and adjust VR1 to ensure the signal is centred at 1.65V.

Users may find that dPMR functionality can be better demonstrated by using a single PE0002 host controller card (which has two C-BUS ports), in place of 2 x PE0002 cards. Using both PE0002 C-BUS ports requires very careful sequencing of operations and is not covered in this user manual. An alternative approach is to use two instances of the PE0002 GUI on a single PC: each GUI then controls one PE0002 host controller card via its USB connector, as discussed above.

7.3. Troubleshooting

After loading a Function Image™ the ES0002xx application writes the activation code that has been typed into the Activation Code edit box to the CMX7140 device. If this code is incorrect for the Function Image™ that has just been loaded, the CMX7140 target device will lock up and will

not respond to further input from the ES0002xx application. It is recoverable only by power cycling the DE6181 card, closing the ES0002xx application and then restarting the application.

7.3.1. Modification State

The modification state (mod state) of the DE6181 can be determined from the 'Board Mod' box printed on the PCB silkscreen. The highest number in the box that is blacked out gives the mod state. The following examples indicate a mod state of 3.

Board Mod			
●	●	●	4
5	6	7	8

Board Mod			
[Blacked out]			4
5	6	7	8

Figure 10 – Examples of Mod State Identification

8. Performance Specification

8.1. Electrical Performance

8.1.1. Absolute Maximum Ratings

Exceeding these maximum ratings can result in damage to the Evaluation Kit.

	Min.	Max.	Units
Supply (+V _{IN} - V _{SS})	-0.3	12.0	V
Supply (-V _{IN} - V _{SS})	+0.3	-12.0	V
Voltage on any connector pin to V _{SS}	-0.3	V _{DD} + 0.3	V
Current into or out of V _{IN} and V _{SS} pins	0	±250	mA
Current into or out of any other connector pin	-20	+20	mA

8.1.2. Operating Limits

Correct operation of the Evaluation Kit outside these limits is not implied.

	Notes	Min.	Max.	Units
Supply (+V _{IN} - V _{SS})		4.5	5.5	V
Supply (-V _{IN} - V _{SS})		-6.0	-7.0	V

8.1.3. Operating Characteristics

For the following conditions unless otherwise specified:

$$+V_{IN} = 5.0V, -V_{IN} = N/C, T_{amb} = +25^{\circ}C.$$

	Notes	Min.	Typ.	Max.	Units
DC Parameters					
I _{DD} (after reset)	1		57		mA
I _{DD} (running code)	1,2		52		mA
AC Parameters					
MOD Outputs					
Voltage swing			2.0		Vp-p
DC offset	3		1.65		V
Load impedance		3			kΩ
MOD BUF Outputs					
Voltage swing			2.0		Vp-p
DC offset	3		0		V
Load impedance		50			Ω
Disc and Alt Inputs					
Voltage swing				2.0	Vp-p
DC Offset	3		1.65		V
Input impedance			10		kΩ
Mic Input					
Input Impedance	5		1		MΩ
Voltage Range				0.66 to 2.64	V
Speaker Output					
Voltage Range				0.33 to 2.97	V
Load Impedance		32			
Differential Output Voltage	4			5.28	V
Differential Output Power	4		120		mW
Line Output					
Voltage swing				0 to 3.3	V
Load impedance		100			kΩ

- Notes:**
1. PCB current consumption, not current consumption of the CMX7140 or CMX618.
 2. This value is highly dependent on the code being run.
 3. DC Coupled
 4. Measured whilst driving a 32Ω resistive load between OUTP and OUTN pins.
 5. Depends on the input configuration jumpers.

Operating Characteristics - Timing Diagrams

Please refer to CMX7041, CMX7141 and CMX618 Datasheets for details.

CML does not assume any responsibility for the use of any circuitry described. No IPR or circuit patent licences are implied. CML reserves the right at any time without notice to change the said circuitry and any part of this product specification. Evaluation kits and demonstration boards are supplied for the sole purpose of demonstrating the operation of CML products and are supplied without warranty. They are intended for use in a laboratory environment only and are not for re-sale, end-use or incorporation into other equipments. Operation of these kits and boards outside a laboratory environment is not permitted within the European Community. All software/firmware is supplied "as is" and is without warranty. It forms part of the product supplied and is licensed for use only with this product, for the purpose of demonstrating the operation of CML products. Whilst all reasonable efforts are made to ensure that software/firmware contained in this product is virus free, CML accepts no responsibility whatsoever for any contamination which results from using this product and the onus for checking that the software/firmware is virus free is placed on the purchaser of this evaluation kit or development board.

 CML Microcircuits (UK) Ltd <small>COMMUNICATION SEMICONDUCTORS</small>	 CML Microcircuits (USA) Inc. <small>COMMUNICATION SEMICONDUCTORS</small>	 CML Microcircuits (Singapore) Pte Ltd <small>COMMUNICATION SEMICONDUCTORS</small>
Tel: +44 (0)1621 875500 Fax: +44 (0)1621 875600 Sales: sales@cmlmicro.com Tech Support: techsupport@cmlmicro.com	Tel: +1 336 744 5050 800 638 5577 Fax: +1 336 744 5054 Sales: us.sales@cmlmicro.com Tech Support: us.techsupport@cmlmicro.com	Tel: +65 62 888129 Fax: +65 62 888230 Sales: sg.sales@cmlmicro.com Tech Support: sg.techsupport@cmlmicro.com
- www.cmlmicro.com -		