

Features

- Low Power Loss, High Efficiency
- Guard Ring for Transient Protection
- High Surge Capability
- Very Low Forward Voltage Drop
- For Use in High Frequency Inverters, Free Wheeling, and Polarity Protection Applications
- **Lead Free Finish, RoHS Compliant (Note 1)**

Mechanical Data

- Case: TO-220AB
- Case Material: Molded Plastic. UL Flammability Classification Rating 94V-0
- Moisture Sensitivity: Level 1 per J-STD-020C
- Terminals: Tin Finish. Solderable per MIL-STD-202, Method 208 (e3)
- Polarity: See Diagram
- Marking: Type Number
- Ordering Information: See Sheet 3
- Weight: 2.24 grams (approximate)

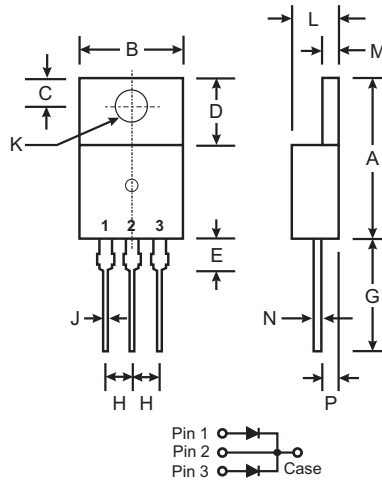

TO-220AB		
Dim	Min	Max
A	14.22	15.88
B	9.65	10.67
C	2.54	3.43
D	5.84	6.86
E	—	6.35
G	12.70	14.73
H	2.29	2.79
J	0.51	1.14
K	3.53 \varnothing	4.09 \varnothing
L	3.56	4.83
M	1.14	1.40
N	0.30	0.64
P	2.03	2.92
All Dimensions in mm		

Maximum Ratings @ T_A = 25°C unless otherwise specified

Single phase, half wave, 60Hz, resistive or inductive load.
For capacitive load, derate current by 20%.

Characteristic	Symbol	Value	Unit
Peak Repetitive Reverse Voltage Working Peak Reverse Voltage DC Blocking Voltage	V _{RRM} V _{RWM} V _R	30	V
RMS Reverse Voltage	V _{R(RMS)}	21	V
Average Rectified Output Current @ T _C = 140°C	I _O	30	A
Total Device Per Element		15	
Non-Repetitive Peak Forward Surge Current 8.3ms Single half sine-wave Superimposed on Rated Load Per Element	I _{FSM}	260	A
Peak Repetitive Reverse Current Per Element at t _p = 2 μ s, 1 KHz	I _{RRM}	1.0	A
Voltage Rate of Change	dV/dt	10,000	V/ μ s
Typical Thermal Resistance Junction to Case (Note 2)	R _{θJC}	1.5	°C/W
Per Diode Total		0.8	
Operating Temperature Range	T _J	-65 to +150	°C
Storage Temperature Range	T _{STG}	-65 to +150	°C

Electrical Characteristics @ T_A = 25°C unless otherwise specified

Characteristic	Symbol	Min	Typ	Max	Unit	Test Condition
Reverse Breakdown Voltage (Note 3)	V _{(BR)R}	30	—	—	V	I _R = 1.5mA
Forward Voltage Per Element	V _F	—	—	0.46 0.38 0.57 0.50	V	@ I _F = 15A, T _J = 25°C @ I _F = 15A, T _J = 125°C @ I _F = 30A, T _J = 25°C @ I _F = 30A, T _J = 125°C
Peak Reverse Current Per Element (Note 3)	I _R	—	—	1.0 300	mA mA	@ V _R = 30V, T _J = 25°C @ V _R = 30V, T _J = 125°C

- Notes:
1. RoHS revision 13.2.2003. Glass and High Temperature Solder Exemptions Applied, see EU Directive Annex, Notes 5 and 7.
 2. Thermal Resistance Junction to Case: Device mounted on 200x200x5mm aluminum plate.
 3. Short duration test pulse used to minimize self-heating effect.

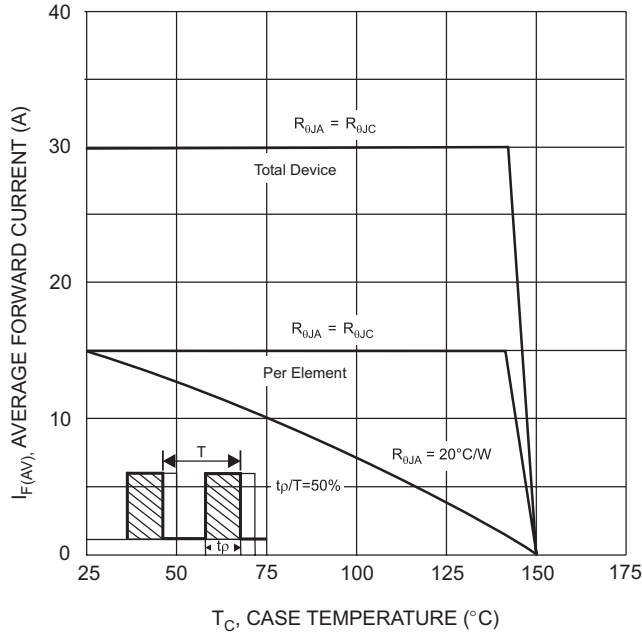

Fig. 1 Forward Current Derating Curve

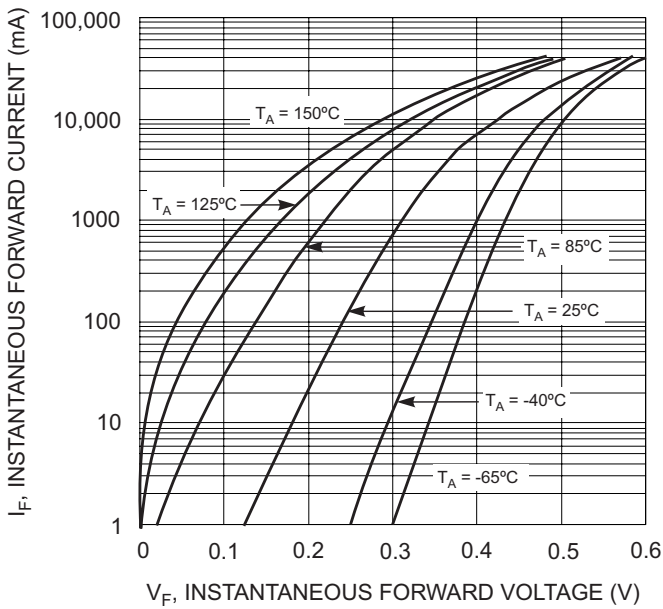

Fig. 3 Typical Forward Characteristics, Per Element

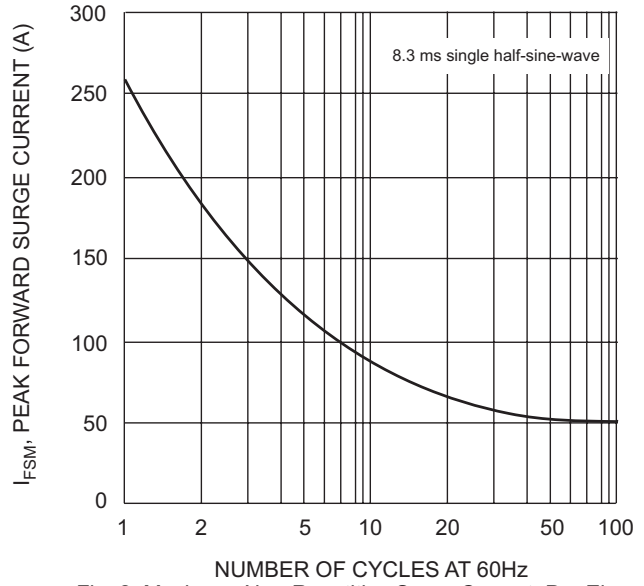

Fig. 2 Maximum Non-Repetitive Surge Current, Per Element

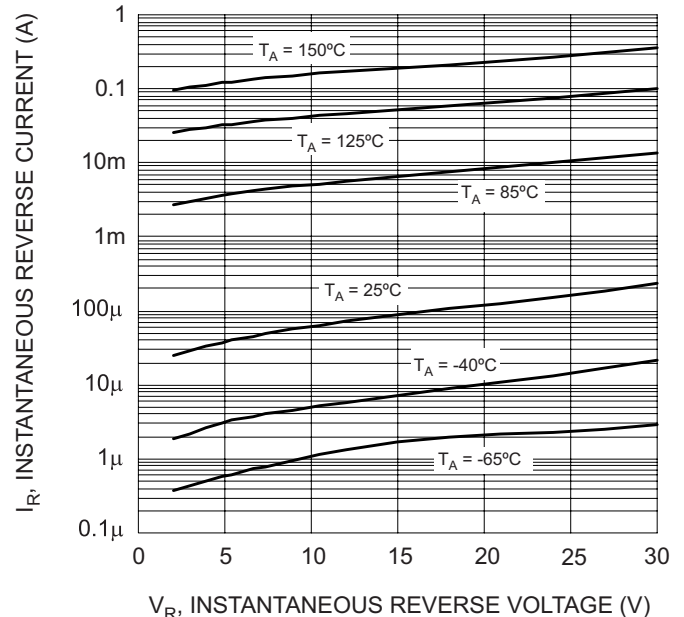

Fig. 4 Typical Reverse Characteristics, Per Element

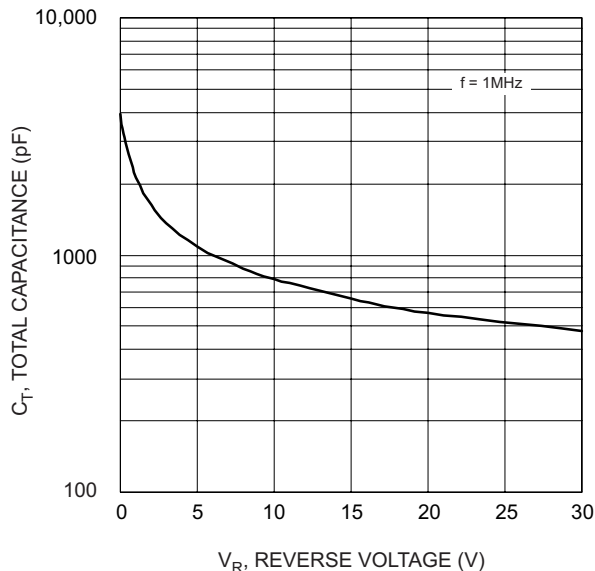

Fig. 5 Typical Total Capacitance, Per Element

Ordering Information (Note 4)

Device	Packaging	Shipping
SBL30L30CT	TO-220AB	50/Tube

Notes: 4. For Packaging Details, go to our website at <http://www.diodes.com/datasheets/ap02007.pdf>.

IMPORTANT NOTICE

Diodes Incorporated and its subsidiaries reserve the right to make modifications, enhancements, improvements, corrections or other changes without further notice to any product herein. Diodes Incorporated does not assume any liability arising out of the application or use of any product described herein; neither does it convey any license under its patent rights, nor the rights of others. The user of products in such applications shall assume all risks of such use and will agree to hold Diodes Incorporated and all the companies whose products are represented on our website, harmless against all damages.

LIFE SUPPORT

Diodes Incorporated products are not authorized for use as critical components in life support devices or systems without the expressed written approval of the President of Diodes Incorporated.