

FEATURES

- *Guaranteed* 10ppm/°C Temperature Coefficient
- *Guaranteed* 1Ω Maximum Dynamic Impedance
- *Guaranteed* 20μV Maximum Wideband Noise
- Wide Operating Current Range: 0.6mA to 15mA

APPLICATIONS

- Transducers
- A/D and D/A Converters
- Calibration Standards
- Instrumentation Reference

DESCRIPTION

The LM129 temperature compensated 6.9V Zener references provide excellent stability over time and temperature, very low dynamic impedance and a wide operating current range. The device achieves low dynamic impedance by incorporating a high gain shunt regulator around the Zener. The excellent noise performance of the device is achieved by using a “buried Zener” design which eliminates surface noise phenomenon associated with ordinary Zeners. To serve a wide variety of applications, the LM129 is available in several temperature coefficient grades and two package styles. A 20mA positive current source application is shown below.

LT, LT, LTC, LTM, Linear Technology and the Linear logo are registered trademarks of Linear Technology Corporation. All other trademarks are the property of their respective owners.

TYPICAL APPLICATION

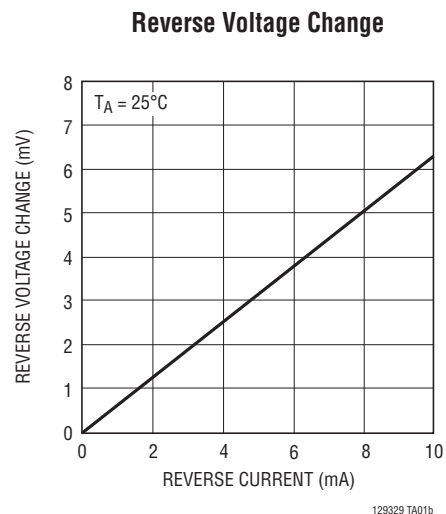
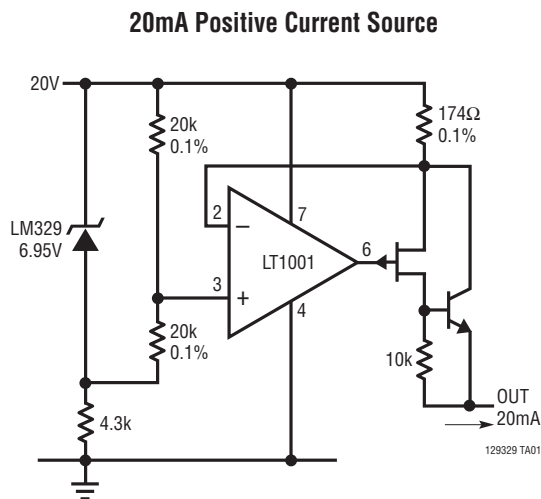

LM129/LM329

ABSOLUTE MAXIMUM RATINGS (Note 1)

Operating Temperature Range	Lead Temperature (Soldering, 10 sec)	300°C
LM129 (OBSOLETE)	Reverse-Breakdown Current	30mA
LM329	Forward Current.....	2mA
Storage Temperature Range.....		

PIN CONFIGURATION

<p style="text-align: center;">BOTTOM VIEW</p>  <p style="text-align: center;">H PACKAGE 2-LEAD TO-46 METAL CAN</p> <p style="text-align: center;">$T_{JMAX} = 150^{\circ}\text{C}$, $\theta_{JA} = 440^{\circ}\text{C/W}$, $\theta_{JC} = 80^{\circ}\text{C/W}$</p> <p style="text-align: center;">OBSOLETE PACKAGE Consider the Z Package for Alternate Source</p>	<p style="text-align: center;">BOTTOM VIEW</p>  <p style="text-align: center;">Z PACKAGE 3-LEAD PLASTIC TO-92</p> <p style="text-align: center;">$T_{JMAX} = 150^{\circ}\text{C}$, $\theta_{JA} = 160^{\circ}\text{C/W}$</p>
---	---

ORDER INFORMATION

LEAD FREE FINISH	TAPE AND REEL	PART MARKING	PACKAGE DESCRIPTION	TEMPERATURE RANGE
LM129AH#PBF	LM129AH#TRPBF	LM129AH	2-Lead Plastic TO-46 Metal Can	-55°C to 125°C
LM129BH#PBF	LM129BH#TRPBF	LM129BH	2-Lead Plastic TO-46 Metal Can	-55°C to 125°C
LM129CH#PBF	LM129CH#TRPBF	LM129CH	2-Lead Plastic TO-46 Metal Can	-55°C to 125°C
LM329AH#PBF	LM329AH#TRPBF	LM329AH	2-Lead Plastic TO-46 Metal Can	0°C to 70°C
LM329BH#PBF	LM329BH#TRPBF	LM329BH	2-Lead Plastic TO-46 Metal Can	0°C to 70°C
LM329CH#PBF	LM329CH#TRPBF	LM329CH	2-Lead Plastic TO-46 Metal Can	0°C to 70°C
LM329DH#PBF	LM329DH#TRPBF	LM329DH	2-Lead Plastic TO-46 Metal Can	0°C to 70°C
LM329AZ#PBF	LM329AZ#TRPBF	LM329AZ	3-Lead Plastic TO-92	0°C to 70°C
LM329BZ#PBF	LM329BZ#TRPBF	LM329BZ	3-Lead Plastic TO-92	0°C to 70°C
LM329CZ#PBF	LM329CZ#TRPBF	LM329CZ	3-Lead Plastic TO-92	0°C to 70°C
LM329DZ#PBF	LM329DZ#TRPBF	LM329DZ	3-Lead Plastic TO-92	0°C to 70°C

Contact LTC Marketing for availability of LM329AZ, LM329CZ and LM329DZ.
 Consult LTC Marketing for parts specified with wider operating temperature ranges.
 Consult LTC Marketing for information on non-standard lead based finish parts.

For more information on lead free part marking, go to: <http://www.linear.com/leadfree/>
 For more information on tape and reel specifications, go to: <http://www.linear.com/tapeandreel/>

ELECTRICAL CHARACTERISTICS

The ● denotes the specifications which apply over the full operating temperature range, otherwise specifications are at $T_A = 25^\circ\text{C}$. (Note 2)

SYMBOL	PARAMETER	CONDITIONS	LM129A/ LM129B/LM129C			LM329A/LM329B/ LM329C/LM329D			UNITS
			MIN	TYP	MAX	MIN	TYP	MAX	
V_Z	Reverse-Breakdown Voltage	$T_A = 25^\circ\text{C}$, $0.6\text{mA} \leq I_R \leq 15\text{mA}$	6.7	6.9	7.2	6.6	6.9	7.25	V
$\frac{\Delta V_Z}{\Delta I_R}$	Reverse-Breakdown Voltage Change with Current	$T_A = 25^\circ\text{C}$, $0.6\text{mA} \leq I_R \leq 15\text{mA}$ $1\text{mA} \leq I_R \leq 15\text{mA}$	●	9 12	14	●	9 12	20	mV mV
$\frac{\Delta V_Z}{\Delta \text{Temp}}$	Temperature Coefficient	$I_R = 1\text{mA}$, LM129A/LM329A LM129B/LM329B LM129C/LM329C LM329D	●	6 15 30	10 20 50	●	6 15 30 50	10 20 50 100	ppm/ $^\circ\text{C}$ ppm/ $^\circ\text{C}$ ppm/ $^\circ\text{C}$ ppm/ $^\circ\text{C}$
	Change in Temperature Coefficient	$1\text{mA} \leq I_R \leq 15\text{mA}$	●	1		●	1		ppm/ $^\circ\text{C}$
r_Z	Dynamic Impedance	$T_A = 25^\circ\text{C}$, $I_R = 1\text{mA}$ $1\text{mA} \leq I_R \leq 15\text{mA}$	●	0.6 0.8	1	●	0.8 1	2	Ω Ω
e_n	RMS Noise	$T_A = 25^\circ\text{C}$, $10\text{Hz} \leq f \leq 10\text{kHz}$		7	20		7	100	μV
$\frac{\Delta V_Z}{\Delta \text{Time}}$	Long-Term Stability	$T_A = 45^\circ\text{C} \pm 0.1^\circ\text{C}$, $I_R = 1\text{mA} \pm 0.3\%$		20			20		ppm/kHz

Note 1: Stresses beyond those listed under Absolute Maximum Ratings may cause permanent damage to the device. Exposure to any Absolute Maximum Rating condition for extended periods may affect device reliability and lifetime.

Note 2: To determine the junction temperature as a function of the ambient temperature, see θ_{JA} for each package.

TYPICAL PERFORMANCE CHARACTERISTICS

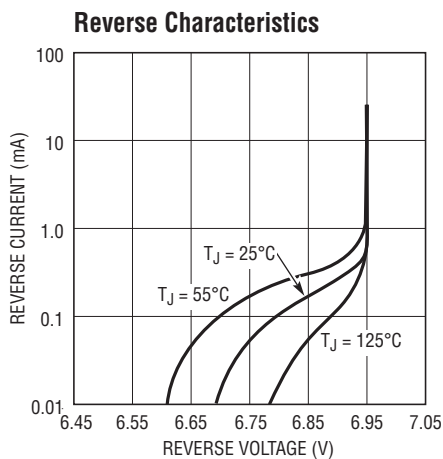

129329 G01

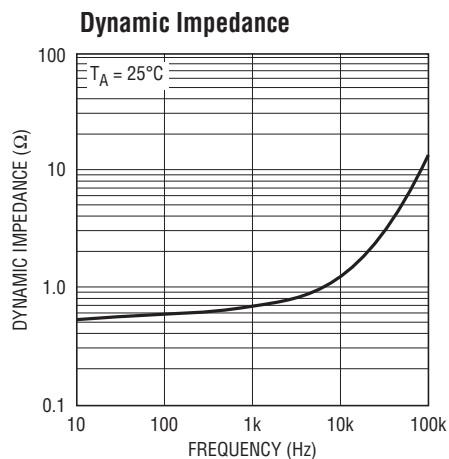

129329 G02

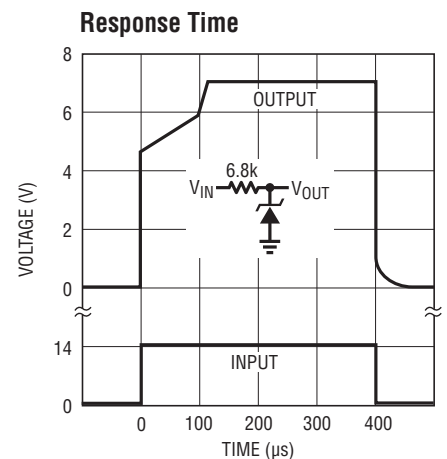

129329 G03

TYPICAL PERFORMANCE CHARACTERISTICS

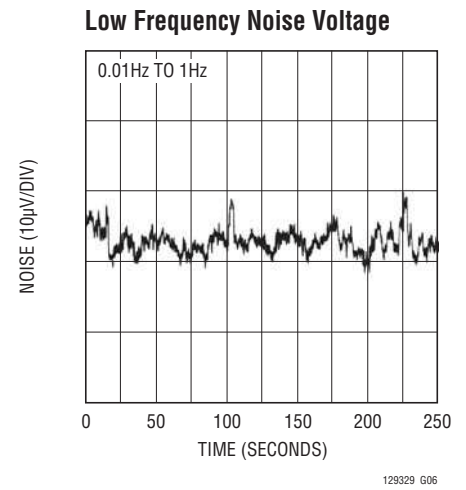
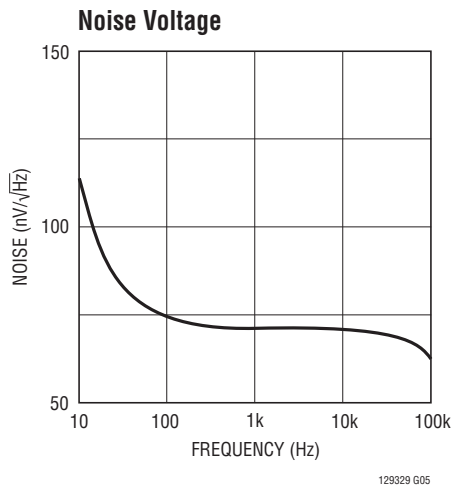
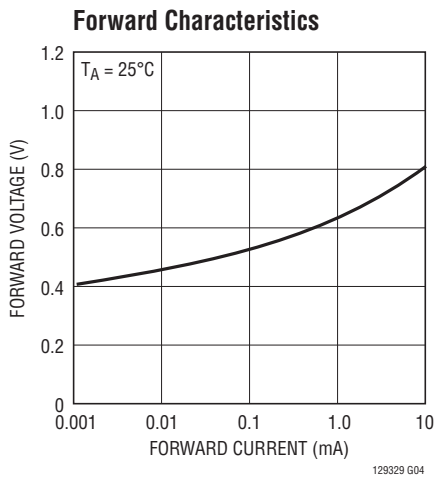

SCHEMATIC DIAGRAM

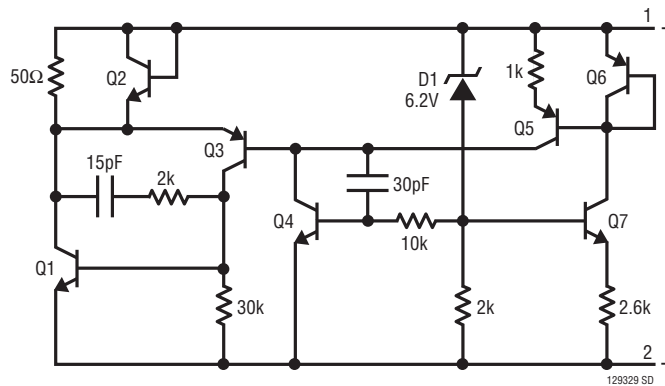

PACKAGE DESCRIPTION

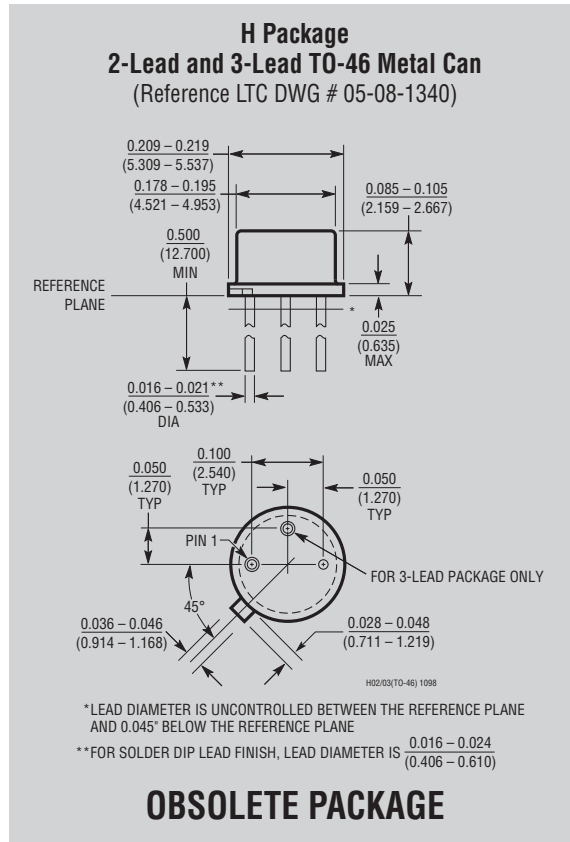

Z Package
3-Lead TO-92 (Similar to TO-226)
 (Reference LTC DWG # 05-08-1410)

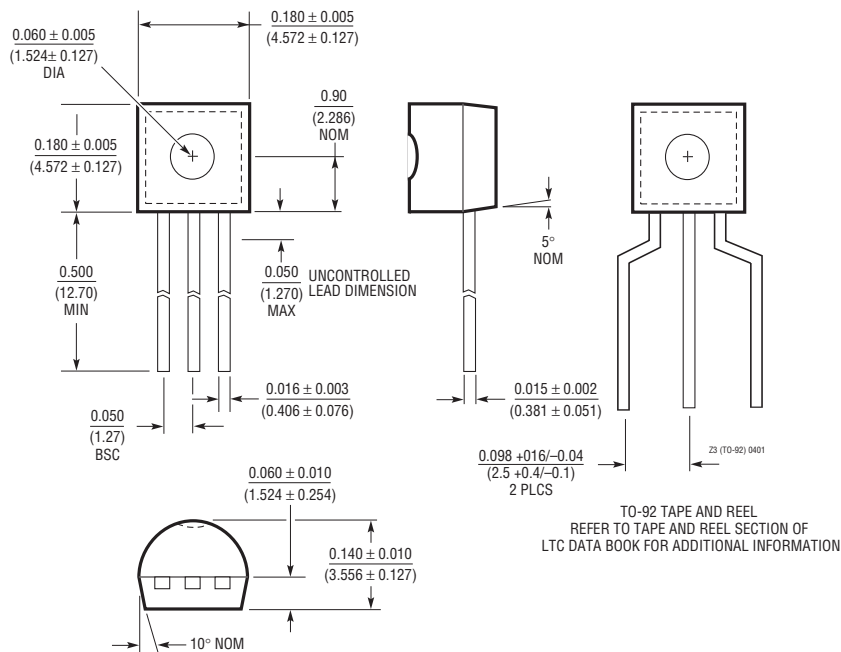

LM129/LM329

TYPICAL APPLICATION

Common Reference

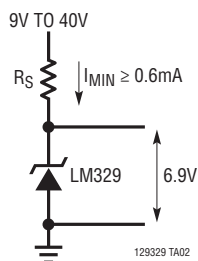

Buffered Reference Using a Single Supply

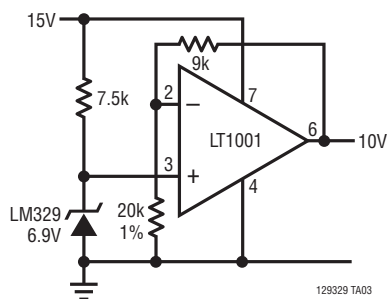

RELATED PARTS

PART NUMBER	DESCRIPTION	COMMENTS
LT [®] 1460	Micropower, Precise Series Reference	10ppm/°C, Output Voltages: 2.5V, 3V, 3.3V, 5V, 10V
LT1634	0.05% Accurate, 10ppm/°C, Shunt Reference	Output Voltages: 1.25V, 2.5V, 4.096V, 5V