

REV	ECN. NO.	APP	DATE
A	EDIÇÃO INICIAL		
B	COTA DE 7,2 ERA 7,9		

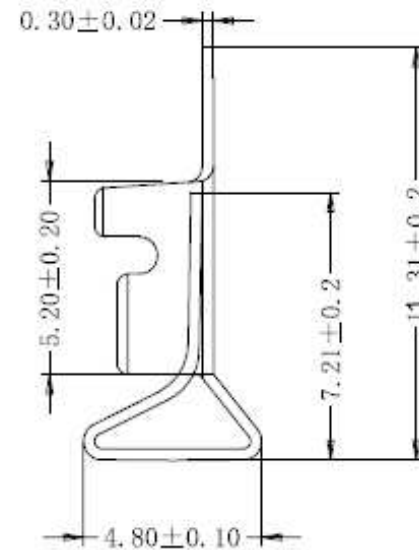

**HOW TO ORDER:**  
**2043TB[ ][ ][02]R**  
**1 2 3**

- 01- ACABAMENTO
- (00)- SEM BANHO
- (01)- COM BANHO ESTANHADO FOSCO
- (03)- NIQUELADO
- 02- MATERIAL
- (01)- LATÃO
- (02)- BRONZE FOSFOROSO
- 03- FORNECIMENTO
- (01)-A GRANEL
- (02)- FITA

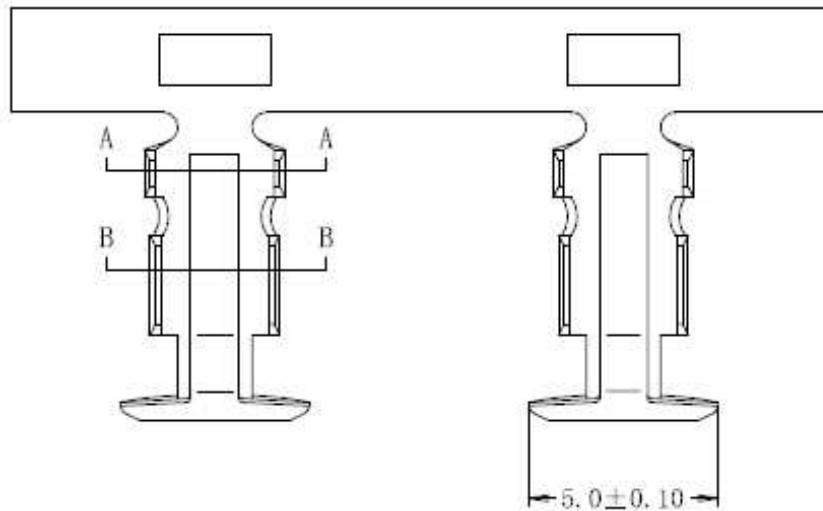
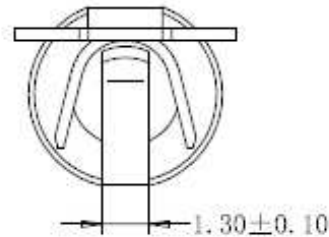
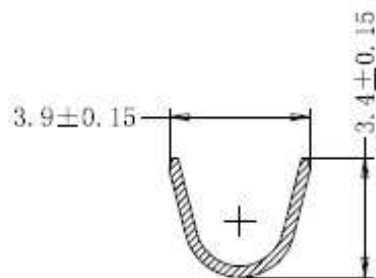

A-A

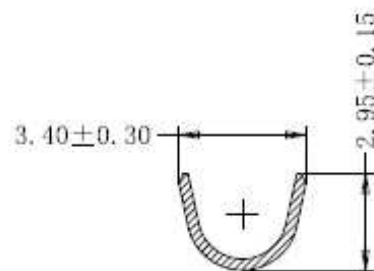

B-B



**MATRIX Tecnologia Ind. e Com. Ltda.**

UNIT mm	SCALE	TITLE	DATE JANUARY 2010
TOLERANCE: ±0.25		Botton 2 Garras Bitola: 0,5 - 1,0mm²	APP. BY
		MATL	CHK. BY
		DWG. NO.	DR. BY <b>Felipe</b>