

REV	ECN. NO.	APP	DATE
A	EDIÇÃO INICIAL		
B	NOVO CÓDIGO		

**SPECIFICATIONS**

WIRE RANGE AWG:16-22 STR  
 RATING:10 AMPERES, 300 VAC  
 INSULATION WITHSTANDS VOLTAGE: AC 2000V/MIN  
 INSULATION RESISTENCE: 500MΩ OR MORE AT DC  
 500V FEATURES

**MATERIAL**

BODY MATERIAL: THERMOPLASTIC (UL 94V-0)  
 TERMINALS: TIN PLATED BRASS  
 SCREWS ZINC PLATED STEEL

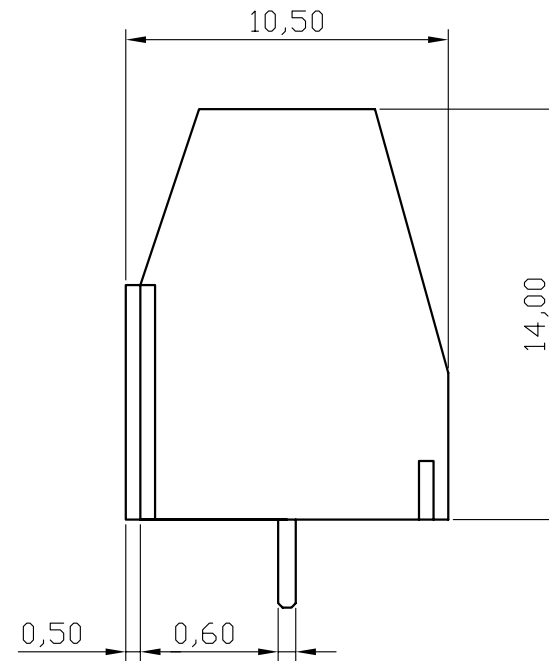
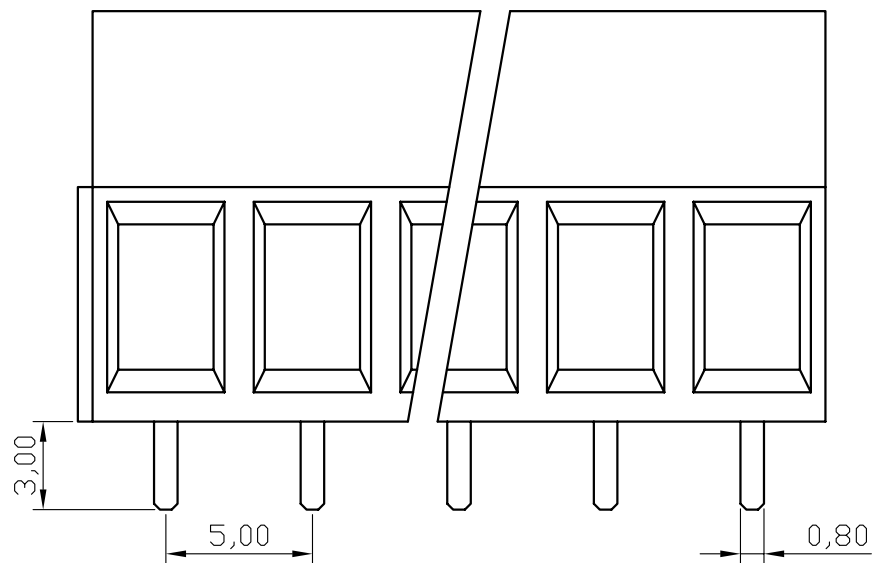
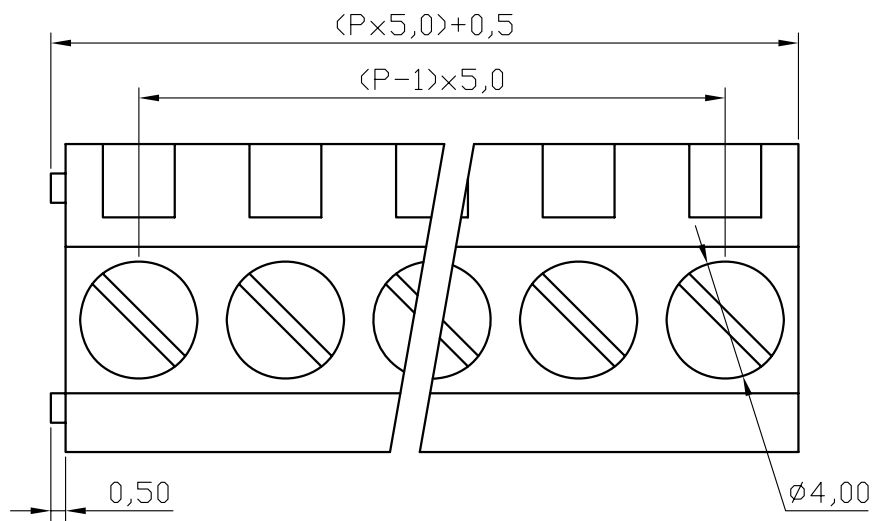

**HOW TO ORDER:**

**5523[ ]CR**

**1**

1- Nr. of Ways

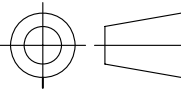

**MATRIX Tecnologia Ind. e Com. Ltda.**

UNIT mm	SCALE 4:1	TITLE 5,0mm TERMINAL BLOCK 180° H=14,00mm	DATE JANUARY 2010
TOLERANCE: $\pm 0,25$			APP. BY
		MATL	CHK. BY
		DWG. NO.	DR. BY FELIPE