

OA5920 'Challenger Series'

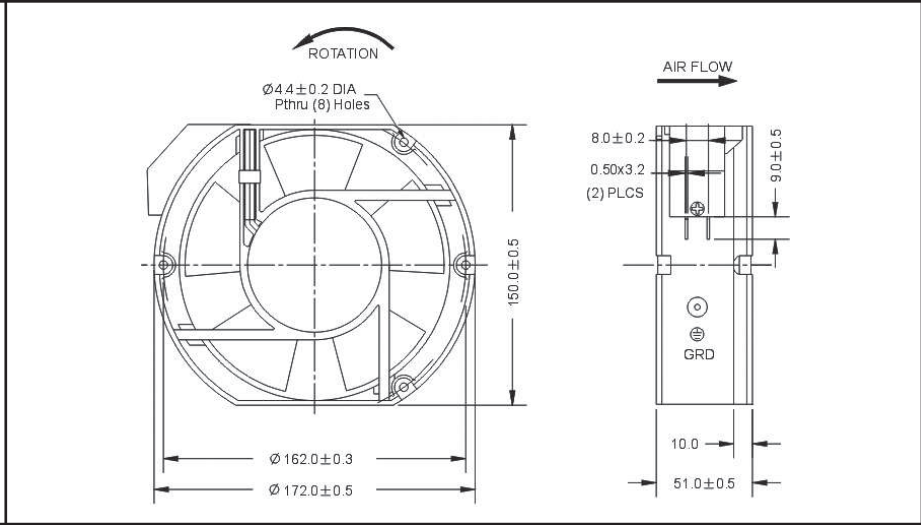

172 x 150 x 51mm
(6.7" x 5.9" x 2.0")



Frame	Diecast Aluminum	<u>Operating Temperature</u> Ball Bearing -10C ~ +70C <u>Life Expectancy</u> Ball Bearing 60,000 hours (L10 at 40C)	
Impeller	PBT, UL94V-O plastic		
Connection	Terminals		
Motor	Shaded pole, thermally protected		
Bearing System	Dual ball (Sleeve available)		
Insulation Resistance	>100M ohm between lead-wire and frame (500VDC)		
Dielectric Strength	1 min at 1500 VAC, 50/60Hz		

Part Number	OA5920-12TB	OA5920-23TB
Nominal Voltage	120 VAC	230 VAC
Voltage Range	80 ~ 130 VAC	160 ~ 260 VAC
Rated Power	41 W (60Hz)	41 W (60Hz)
Rated Speed (RPM)	3000	3000
Airflow (CFM)	180	180
Noise Level (dB)	55	55
Max. Static Pressure	0.51" H ₂ O	0.51" H ₂ O