

# AUTOMOTIVE CURRENT TRANSDUCER HC6H800-S



## Introduction

The HC6H family is for use on the electronic measurement of DC, AC or pulsed currents in high power and low voltage automotive applications with a galvanic isolation between the primary circuit (high power) and the secondary circuit (electronic circuit)

The HC6H family gives you the choice of having different current measuring ranges in the same housing.

## Features

- Open Loop transducer using the Hall effect
- Low voltage application
- Unipolar + 5 V DC power supply
- Primary current measuring range from 200 A up to 800 A
- Maximum rms primary admissible current: defined by busbar the magnetic core or the ASIC to have  $T^{\circ} < + 150^{\circ}\text{C}$
- Operating temperature range:  $- 40^{\circ}\text{C} < T^{\circ} < + 125^{\circ}\text{C}$
- Output voltage: full ratio-metric (in gain and offset)
- Compact design for PCB mounting.

## Advantages

- Excellent accuracy
- Very good linearity
- Very low thermal offset drift
- Very low thermal gain drift
- Wide frequency bandwidth
- No insertion losses.
- Very good ratio size/current range.

## Automotive applications

- Starter Generators
- Converters
- Inverters
- Drives.

## Principle of HC6H Family

The open loop transducers use an Hall effect integrated circuit.

The magnetic flux density  $B$ , contributing to the rise of the Hall voltage, is generated by the primary current  $I_p$  to be measured.

The current to be measured  $I_p$  is supplied by a current source i.e. battery or generator (Fig. 1).

Within the linear region of the hysteresis cycle,  $B$  is proportional to:

$$B (I_p) = \text{constant} (a) \times I_p$$

The Hall voltage is thus expressed by:

$$V_H = (R_H/d) \times l \times \text{constant} (a) \times I_p$$

Except for  $I_p$ , all terms of this equation are constant. Therefore:

$$V_H = \text{constant} (b) \times I_p$$

The measurement signal  $V_H$  amplified to supply the user output voltage or current.

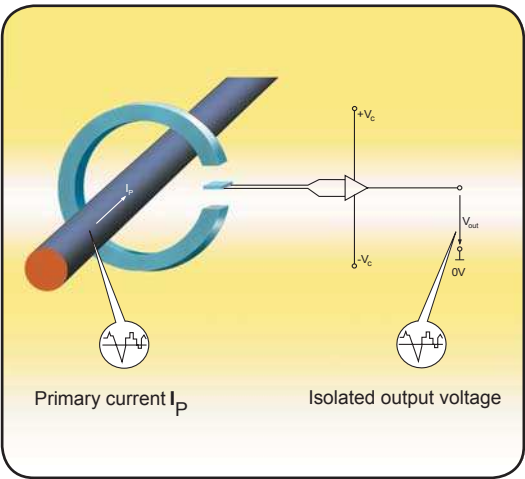

Fig. 1: Principle of the open loop transducer

# HC6H800-S

Dimensions HC6H xxx-S family (in mm. 1mm = 0.0394 inch)

## Secondary connection

Terminals	Designations
3	Supply voltage + 5 V DC
1	V <sub>OUT</sub>
2	Ground
E1, E2	Ground (*)

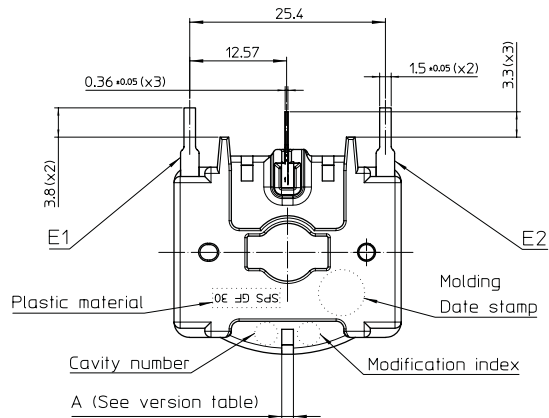
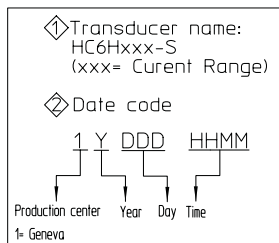

(\*) Only 1 of these 2 pins could be connected

## Connection

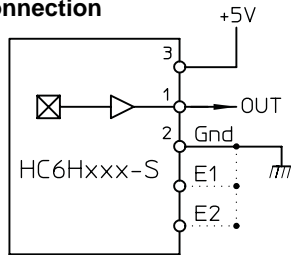

xxx= Current Range

VERSION TABLE of CURRENT RANGE	
A	CURRENT RANGE
1.5 mm	I <sub>p</sub> ≤ 600 A
3 mm	I <sub>p</sub> > 600 A

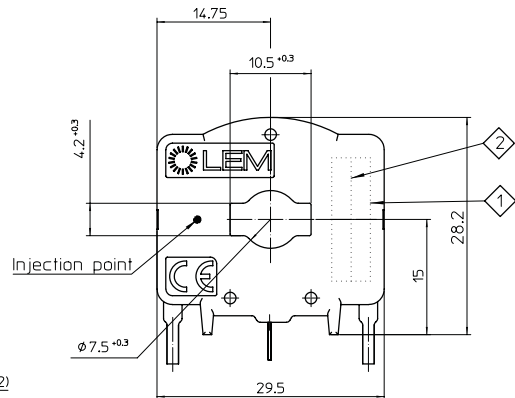
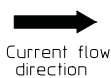
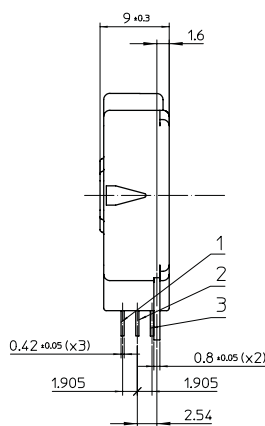

## Bill of materials

- Plastic case: SPS GF 30
- Magnetic core: FeSi alloy
- Pins: Copper alloy tin plated (lead free)
- Mass: 23 g

## Remarks

- General tolerance: ± 0.2 mm
- V<sub>OUT</sub> >  $\frac{V_e}{2}$  when I<sub>p</sub> flows in the direction of the arrow.

## Electronic schematic

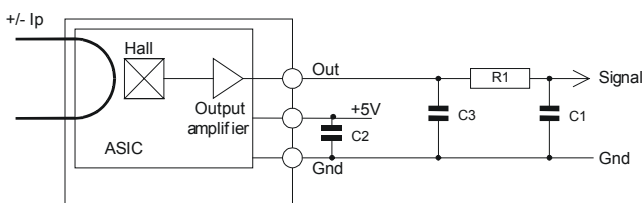

Power supply decoupling capacitor: C2 = 47 nF  
 EMC protection capacitor: C3 = 4.7 nF

Optional:

High frequency signal noise filter:

R1 > 100 Ω

C1 = defined according to the system frequency bandwidth.

## HC6H800-S

### Absolute maximum ratings (not operating)

Parameter	Symbol	Unit	Specification	Conditions
Maximum peak primary current (not operating)	$I_{P,max}$	A	Defined by busbar to have $T^\circ \leq 150^\circ\text{C}$	
Primary nominal DC or current rms	$I_{PN}$	A	Defined by busbar to have $T^\circ \leq 150^\circ\text{C}$	
Maximum supply voltage (not operating)	$V_{C,max}$	V	7	
Secondary maximum admissible power	$P_{S,max}$	mW	150	
Ambient operating temperature	$T_A$	$^\circ\text{C}$	$-40 < T_A < 125^\circ\text{C}$	
Ambient storage temperature	$T_S$	$^\circ\text{C}$	$-40 < T_S < 125^\circ\text{C}$	
Electrostatic discharge voltage	$V_{ESD}$	V	2000	JESD22-A114-B
Maximum admissible vibration	$\gamma$	$\text{m.s}^{-2}$	<sup>3)</sup>	see note <sup>3)</sup>
Rms voltage for AC isolation test 50 Hz, 1 min	$V_d$	V	2000	IEC 60664-1
Reverse voltage <sup>4)</sup>	$V_C$	V	0.5	1 min @ $T_A = 25^\circ\text{C}$

### Operating characteristics

	Symbol	Unit	Specification			Conditions
			Min	Typical	Max	
<b>Electrical Data</b>						
Primary current, measuring range	$I_{PM}$	A	-800	-	800	@ $-40^\circ\text{C} < T^\circ < 125^\circ\text{C}$
Supply voltage <sup>1)</sup>	$V_C$	V	4.75	5	5.25	@ $-40^\circ\text{C} < T^\circ < 125^\circ\text{C}$
Output voltage (Analog)	$V_{OUT}$	V	$V_{OUT} = V_C/5 \times (2.5 + 0.0025 \times I_p)$			@ $-40^\circ\text{C} < T^\circ < 125^\circ\text{C}$
Sensitivity	<b>G</b>	V/A	0.00245	0.0025	0.0255	@ $T_A = 25^\circ\text{C}$
Offset voltage	$V_O$	V	2.485	2.5	2.515	@ $V_C = 5\text{ V}; T_A = 25^\circ\text{C}; I_p = 0\text{ A}$
Current consumption	$I_C$	mA	-	15	20	@ $-40^\circ\text{C} < T^\circ < 125^\circ\text{C}; 4.75\text{ V} < V_C < 5.25\text{ V}$
Load resistance	$R_L$	$\text{K}\Omega$	10	-	-	
Output internal resistance	$R_{OUT}$	$\Omega$	-	-	10	
<b>Performance Data</b>						
Sensitivity error	$\epsilon_G$	%	-2.0	$\pm 0.7$	2.0	@ $T_A = 25^\circ\text{C}, V_C = 5\text{ V}; G_{th} = 0.0025$
Electrical offset	$I_{OF}$	A	-3.2	$\pm 1.6$	3.2	@ $V_C = 5\text{ V}; T_A = 25^\circ\text{C}$
	$V_{OF}$	mV	-8	$\pm 4$	8	
Magnetic offset	$I_{OM}$	A	-2.8	$\pm 1.6$	2.8	@ After excursion to $\pm I_p; T_A = 25^\circ\text{C}$
	$V_{OM}$	mV	-7	$\pm 4$	7	
Temperature coefficient of	$TCI_{OF}$	$\text{mA}/^\circ\text{C}$	-64	$\pm 32$	64	@ $-40^\circ\text{C} < T^\circ < 125^\circ\text{C}; V_C = 5\text{ V}$
	$TCV_{OF}$	$\text{mV}/^\circ\text{C}$	-0.16	$\pm 0.08$	0.16	@ $-40^\circ\text{C} < T^\circ < 125^\circ\text{C}; V_C = 5.00\text{ V}$
Temperature coefficient of <b>G</b>	<b>TCG</b>	$\%/^\circ\text{C}$	-0.04	$\pm 0.02$	0.04	@ $-40^\circ\text{C} < T^\circ < 125^\circ\text{C}; V_C = 5\text{ V}$
Linearity error	$\epsilon_L$	$\% I_p$	-1.0	$\pm 0.4$	1.0	@ $I_p; V_C = 5\text{ V}, T_A = 25^\circ\text{C}$
Response time	$t_r$	$\mu\text{s}$	-	8	15	@ $di/dt = 50\text{ A}/\mu\text{s}; I_T = 600\text{ A}$
Frequency bandwidth <sup>2)</sup>	<b>BW</b>	kHz	20	-	-	@ -3 dB; $I_T = 100\text{ A rms}$
Output voltage noise peak-peak	$V_{no,p-p}$	mV	-	10	13.6	@ $T_A = 25^\circ\text{C}; 0\text{ Hz} < f < 1\text{ MHz}$
Output voltage noise rms	$V_{no,rms}$	mV	-	2.5	3.5	@ $T_A = 25^\circ\text{C}; 0\text{ Hz} < f < 1\text{ MHz}$

Notes: <sup>1)</sup> The output voltage  $V_{OUT}$  is fully ratio-metric and depends on the supply voltage  $V_C$ . The  $V_C$  value must be measured and used with the following formula:

$$I_p = \left( V_{OUT} - \frac{V_C}{2} \right) \times \frac{1}{G} \times \frac{5}{V_C} \quad \text{with G in (V/A)}$$

<sup>2)</sup> Small signal only to avoid excessives heatings of the busbar, the magnetic core and the ASIC ( $< 150^\circ\text{C}$ )

<sup>3)</sup> Depending on the customer application's set up

<sup>4)</sup> Transducer not protected against reverse polarity.

## HC6H800-S

### PERFORMANCES PARAMETERS DEFINITIONS

#### Output noise voltage:

The output voltage noise is the result of the noise floor of the Hall elements and the linear  $I_C$  amplifier gain.

#### Magnetic offset:

The magnetic offset is the consequence of an over-current on the primary side. It's defined after an excursion of  $I_{P\ max}$ .

#### Linearity:

The maximum positive or negative discrepancy with a reference straight line  $V_{OUT} = f(I_P)$ .

Unit: linearity (%) expressed with full scale of  $I_{P\ max}$ .

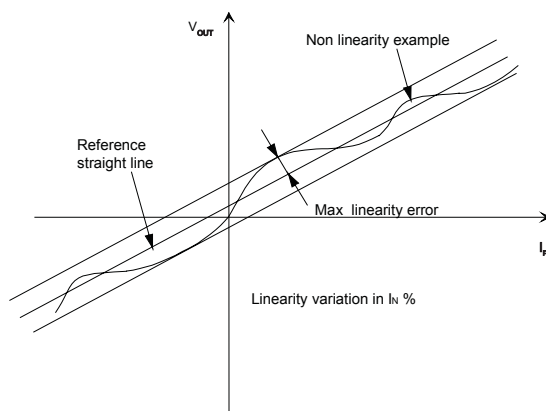

#### Response time (delay time) $t_r$ :

The time between the primary current signal and the output signal reach at 90 % of its final value

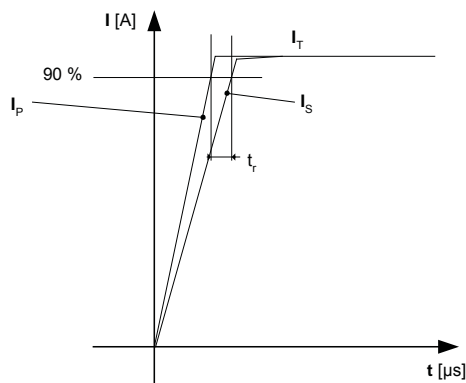

#### Typical:

Theoretical value or usual accuracy recorded during the production.

#### Sensitivity:

The Transducer's sensitivity  $G$  is the slope of the straight line  $V_{out} = f(I_P)$ , it must establish the relation:

$$V_{out}(I_P) = V_C/5 (G \times I_P + 2.5) (*)$$

(\*) For all symetrics transducers.

#### Offset with temperature:

The error of the offset in the operating temperature is the variation of the offset in the temperature considered with the initial offset at 25°C.

The offset variation  $I_{OT}$  is a maximum variation the offset in the temperature range:

$$I_{OT} = I_{OE\ max} - I_{OE\ min}$$

The Offset drift  $TCI_{OEAV}$  is the  $I_{OT}$  value divided by the temperature range.

#### Sensitivity with temperature:

The error of the sensitivity in the operating temperature is the relative variation of sensitivity with the temperature considered with the initial offset at 25°C.

The sensitivity variation  $G_T$  is the maximum variation (in ppm or %) of the sensitivity in the temperature range:

$$G_T = (Sensitivity\ max - Sensitivity\ min) / Sensitivity\ at\ 25^\circ C.$$

The sensitivity drift  $TCG_{AV}$  is the  $G_T$  value divided by the temperature range.

#### Offset voltage @ $I_p = 0$ A:

Is the output voltage when the primary current is null. The ideal value of  $V_o$  is  $V_C/2$  at  $V_C = 5$  V. So, the difference of  $V_o - V_C/2$  is called the total offset voltage error. This offset error can be attributed to the electrical offset (due to the resolution of the ASIC quiescent voltage trimming), the magnetic offset, the thermal drift and the thermal hysteresis.

#### Environmental test specifications

Name	Standard	Conditions
Thermal shocks	IEC 60068 Part 2-14	T° - 40°C to 125°C /1000 cycles not connected
Low T° operation at min supply voltage	IEC 60068 Part 2-1	T° - 40°C / 1000 H supply voltage = 4.75 V
High T° operation at max supply voltage	IEC 60068 Part 2-2	T° 125°C / 1000 H supply voltage = 5.25 V
Temperature humidity bias	IEC 60068 Part 2-3	T° 85°C / 85 % RH/ 1000 H
<b>Mechanical Tests</b>		
Vibration	IEC 60068 Part 2-64	see note <sup>3)</sup> page 3
Drop test	IEC 60068 Part 2-29	Height 750 mm concrete floor each directions
<b>EMC Test</b>		
Electrostatic discharge	JESD22-A114-B	Applied voltage = ± 2 kV pin to pin number of discharge = 1
Rms voltage for AC isolation test	IEC 60664 Part 1	2 kV, 50 Hz, 1 min
Bulk current injected-radiated immunity	ISO 11452 Part 4	