

DIODE MODULE (F.R.D.)

DD250GB

UL;E76102(M)

Power Diode Module **DD250GB** series are designed for various rectifier circuits. **DD250GB** has two diode chips connected in series in a package and the mounting base is electrically isolated from elements for simple heatsink construction. Wide voltage rating up to 800V is available for various input voltage.

- Isolated mounting base
- Two elements in a package for simple (single and three phase) bridge connections
- Highly reliable glass passivated chips
- High surge current capability

(Applications)

Various rectifiers, Battery chargers, DC motor drives

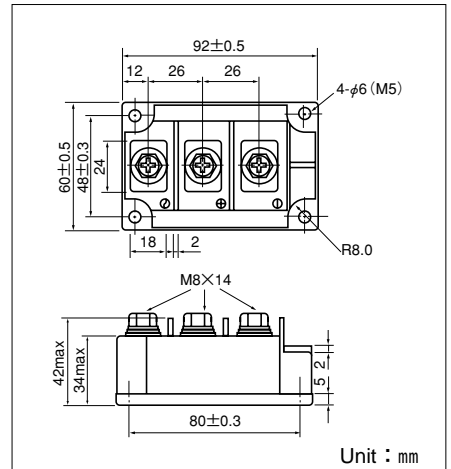

Maximum Ratings

(T_j=25°C unless otherwise specified)

| Symbol | Symbol | Ratings | | Unit |
|------------------|-------------------------------------|-----------|-----------|------|
| | | DD250GB40 | DD250GB80 | |
| V _{RRM} | Repetitive Peak Reverse Voltage | 400 | 800 | V |
| V _{RSM} | Non-Repetitive Peak Reverse Voltage | 480 | 960 | V |

| Symbol | Symbol | Conditions | Ratings | Unit | |
|---------------------|--------------------------------------|--|-----------------------------------|------------------|-----------------|
| I _{F(AV)} | Average Forward Current | Single phase, half wave, 180°C conduction, T _c : 98°C | 250 | A | |
| I _{F(RMS)} | R.M.S. Forward Current | Single phase, half wave, 180°C conduction, T _c : 98°C | 390 | A | |
| I _{FSM} | Surge Forward Current | ½ cycle, 50/60Hz, peak value, non-repetitive | 5000/5500 | A | |
| I ² t | I ² t | Value for one cycle of surge current | 125000 | A ² S | |
| T _j | Operating Junction Temperature | | -40 to +150 | °C | |
| T _{stg} | Storage Temperature | | -40 to +125 | °C | |
| V _{ISO} | Isolation Breakdown Voltage (R.M.S.) | A.C. 1 minute | 2500 | V | |
| | Mounting Torque | Mounting (M5) | Recommended Value 1.5-2.5 (15-25) | 2.7 (28) | N·m (kgf·cm) |
| | | Terminal (M8) | Recommended Value 8.8-10 (90-105) | 11 (115) | |
| | Mass | Typical Value | 510 | g | |

Electrical Characteristics

| Symbol | Symbol | Conditions | Ratings | | | Unit |
|----------------------|---------------------------------|--|---------|------|------|------|
| | | | Min. | Typ. | Max. | |
| I _{RRM} | Repetitive Peak Reverse Current | T _j =150°C at V _{RRM} | | | 50 | mA |
| V _{FM} | Forward Voltage Drop | T _j =25°C, I _{FM} =750A, Inst. measurement | | | 1.45 | V |
| R _{th(j-c)} | Thermal Impedance | Junction to case | | | 0.14 | °C/W |

