

# Current Transducer LT 505-T/SP3

$I_{PN} = 500 \text{ A}$

For the electronic measurement of currents : DC, AC, pulsed..., with a galvanic isolation between the primary circuit (high power) and the secondary circuit (electronic circuit).



16271

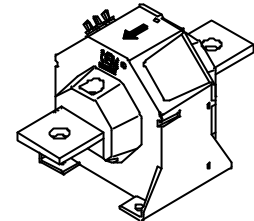

## Electrical data

$I_{PN}$	Primary nominal r.m.s. current	500	A					
$I_P$	Primary current, measuring range	0 .. $\pm 1000$	A					
$R_M$	Measuring resistance @	$T_A = 70^\circ\text{C}$		$T_A = 85^\circ\text{C}$				
		$R_{M \min}$	$R_{M \max}$	$R_{M \min}$	$R_{M \max}$			
		with $\pm 15 \text{ V}$	@ $\pm 500 \text{ A}_{\max}$	0	60	0	58	$\Omega$
			@ $\pm 1000 \text{ A}_{\max}$	0	17	0	15	$\Omega$
	with $\pm 24 \text{ V}$	@ $\pm 500 \text{ A}_{\max}$	10	115	15	113	$\Omega$	
		@ $\pm 1000 \text{ A}_{\max}$	10	45	15	43	$\Omega$	
$I_{SN}$	Secondary nominal r.m.s. current	143	mA					
$K_N$	Conversion ratio	1 : 3500						
$V_C$	Supply voltage ( $\pm 10\%$ )	$\pm 15 \dots 24$	V					
$I_C$	Current consumption	30 (@ $\pm 24\text{V}$ ) + $I_S$	mA					
$V_d$	R.m.s. voltage for AC isolation test, 50 Hz, 1 mn	6	kV					
$V_b$	R.m.s. rated voltage <sup>1)</sup> , safe separation	basic isolation	1750	V				
			3500	V				

## Features

- Closed loop (compensated) current transducer using the Hall effect
- isolated plastic case recognized according to UL 94-V0.

## Special features

- $I_P = 0 \dots \pm 1000 \text{ A}$
- $K_N = 1 : 3500$
- $T_A = -40^\circ\text{C} \dots +85^\circ\text{C}$
- Connection to secondary circuit on M4 threaded studs
- Potted
- Railway equipment.

## Accuracy - Dynamic performance data

$X_G$	Overall accuracy @ $I_{PN}$ , $T_A = 25^\circ\text{C}$	$\pm 0.6$	%
$\epsilon_L$	Linearity	$< 0.1$	%
$I_O$	Offset current @ $I_P = 0$ , $T_A = 25^\circ\text{C}$	Typ	$\pm 0.6$ mA
		Max	$\pm 0.6$ mA
$I_{OT}$	Thermal drift of $I_O$ - $40^\circ\text{C} \dots +85^\circ\text{C}$	$\pm 0.3$	mA
$t_r$	Response time <sup>2)</sup> @ 90 % of $I_{PN}$	$< 1$	$\mu\text{s}$
$di/dt$	di/dt accurately followed	$> 50$	A/ $\mu\text{s}$
$f$	Frequency bandwidth (-1 dB)	DC .. 150	kHz

## Advantages

- Excellent accuracy
- Very good linearity
- Low temperature drift
- Optimized response time
- Wide frequency bandwidth
- No insertion losses
- High immunity to external interference
- Current overload capability.

## General data

$T_A$	Ambient operating temperature	-40 .. +85	$^\circ\text{C}$
$T_S$	Ambient storage temperature	-50 .. +100	$^\circ\text{C}$
$R_S$	Secondary coil resistance @	$T_A = 70^\circ\text{C}$	25 $\Omega$
		$T_A = 85^\circ\text{C}$	27 $\Omega$
$m$	Mass Standards		1.4 kg
			EN 50155 : 1995

## Applications

- AC variable speed drives and servo motor drives
- Static converters for DC motor drives
- Battery supplied applications
- Uninterruptible Power Supplies (UPS)
- Switched Mode Power Supplies (SMPS)
- Power supplies for welding applications.

**Notes** : <sup>1)</sup> Pollution class 2. With a non insulated primary bar which fills the through-hole

<sup>2)</sup> With a di/dt of 100 A/ $\mu\text{s}$ .

070427/11

## Dimensions LT 505-T/SP3 (in mm. 1 mm = 0.0394 inch)

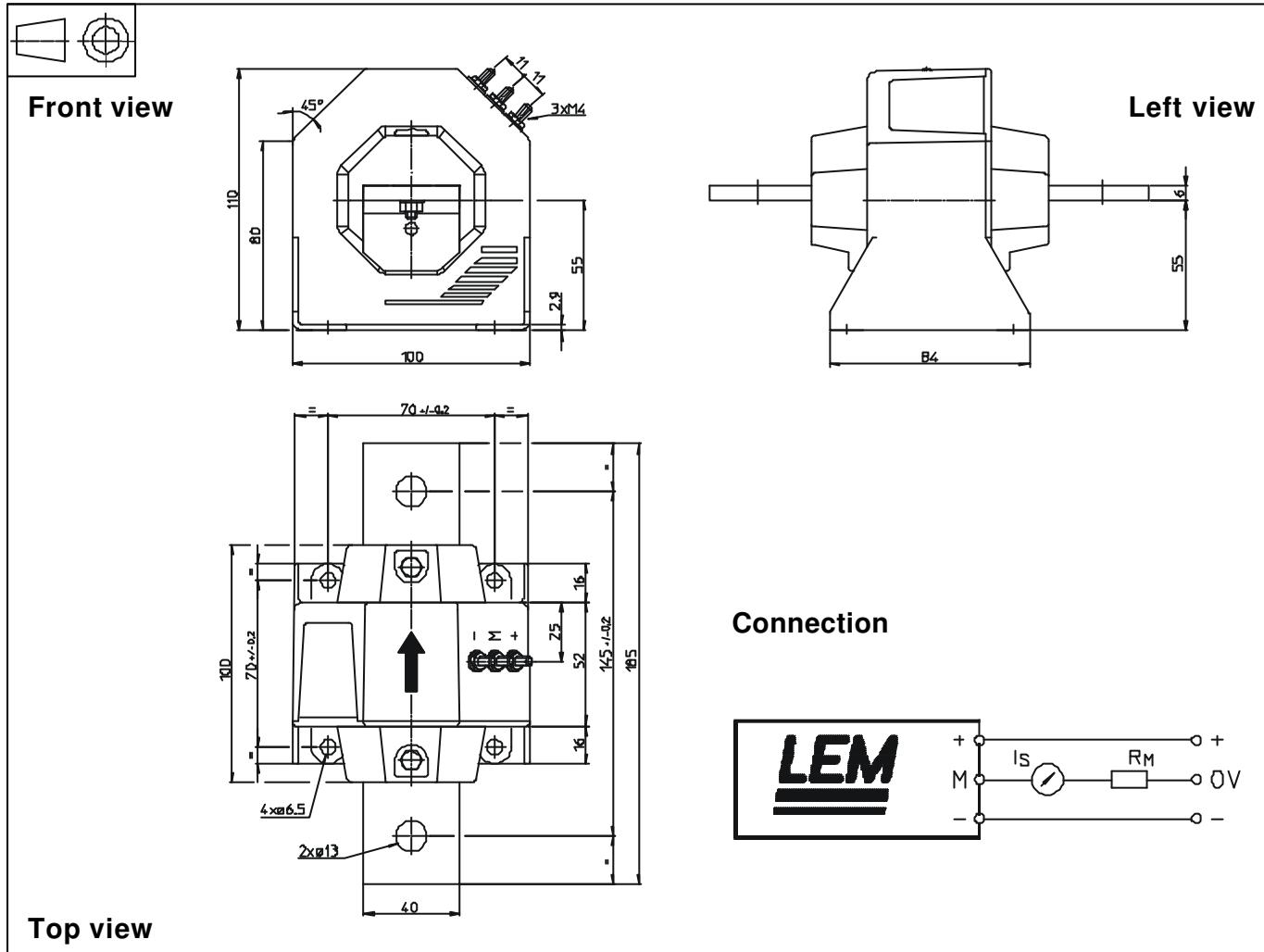

### Mechanical characteristics

- General tolerance  $\pm 0.5$  mm
- Transducer fastening
  - 4 holes  $\varnothing 6.5$  mm
  - 4 M6 steel screws
  - Recommended fastening torque 5 Nm or 3.69 Lb - Ft
  - Or by the primary bar
- Connection of primary 2 holes  $\varnothing 13$  mm
- Connection of secondary M4 threaded studs
- Recommended fastening torque 1.2 Nm or .88 Lb - Ft

### Remarks

- $I_s$  is positive when  $I_p$  flows in the direction of the arrow.
- Temperature of the primary conductor should not exceed 100 °C.