

Current Transducer LT 505-T/SP15

$$I_{PN} = 250 \text{ A}$$

For the electronic measurement of currents : DC, AC, pulsed..., with a galvanic isolation between the primary circuit (high power) and the secondary circuit (electronic circuit).



Electrical data

I_{PN}	Primary nominal r.m.s. current	250	A		
I_p	Primary current, measuring range	0 .. ± 1000	A		
R_M	Measuring resistance @ with $\pm 15 \text{ V}$	$R_{M \text{ min}}$	$R_{M \text{ max}}$		
			@ $\pm 250 \text{ A}_{\text{max}}$	10	166
		@ $\pm 1000 \text{ A}_{\text{max}}$	10	16	Ω
I_{SN}	Secondary nominal r.m.s. current	62.5	m A		
K_N	Conversion ratio	1 : 4000			
V_C	Supply voltage ($\pm 10 \%$)	± 15	V		
I_C	Current consumption	$30 + I_S$	m A		
V_d	R.m.s. voltage for AC isolation test, 50 Hz, 1 mn	$7.4^{1)}$	kV		
		$1^{2)}$	kV		

Accuracy - Dynamic performance data

X_G	Overall accuracy @ I_{PN} , $T_A = 25^\circ\text{C}$	± 0.85	%	
\mathcal{E}_L	Linearity	< 0.1	%	
I_O	Offset current @ $I_p = 0$, $T_A = 25^\circ\text{C}$	Typ	Max	
		± 0.2	± 0.5	m A
I_{OT}	Thermal drift of I_O (- 25°C .. + 70°C)	± 0.2	± 0.4	m A
t_r	Response time ³⁾ @ 90 % of I_{PN}	< 1	μs	
di/dt	di/dt accurately followed	> 50	A/ μs	
f	Frequency bandwidth (-1 dB)	DC .. 150	kHz	

General data

T_A	Ambient operating temperature	- 25 .. + 70	$^\circ\text{C}$
T_S	Ambient storage temperature	- 40 .. + 85	$^\circ\text{C}$
R_S	Secondary coil resistance @ $T_A = 70^\circ\text{C}$	34	Ω
m	Mass	1.4	kg
	Standards	EN 50155	

Notes : ¹⁾ Between primary and secondary + shield

²⁾ Between secondary and shield

³⁾ With a di/dt of 100 A/ μs .

Features

- Closed loop (compensated) current transducer using the Hall effect
- Insulated plastic case recognized according to UL 94-V0.

Special features

- $I_{PN} = 250 \text{ A}$
- $I_p = 0 .. \pm 1000 \text{ A}$
- $K_N = 1 : 4000$
- $V_C = \pm 15 (\pm 10 \%) \text{ V}$
- $V_d = 7.4 \text{ kV}^{1)}$
- $T_A = - 25^\circ\text{C} .. + 70^\circ\text{C}$
- Shield between primary and secondary
- Connection to secondary circuit on M4 threaded studs
- Potted
- VRT Burn-in
- Railway equipment.

Advantages

- Excellent accuracy
- Very good linearity
- Low temperature drift
- Optimized response time
- Wide frequency bandwidth
- No insertion losses
- High immunity to external interference
- Current overload capability.

Applications

- AC variable speed drives and servo motor drives
- Static converters for DC motor drives
- Battery supplied applications
- Uninterruptible Power Supplies (UPS)
- Switched Mode Power Supplies (SMPS)
- Power supplies for welding applications.

070427/2

Dimensions LT 505-T/SP15 (in mm. 1 mm = 0.0394 inch)

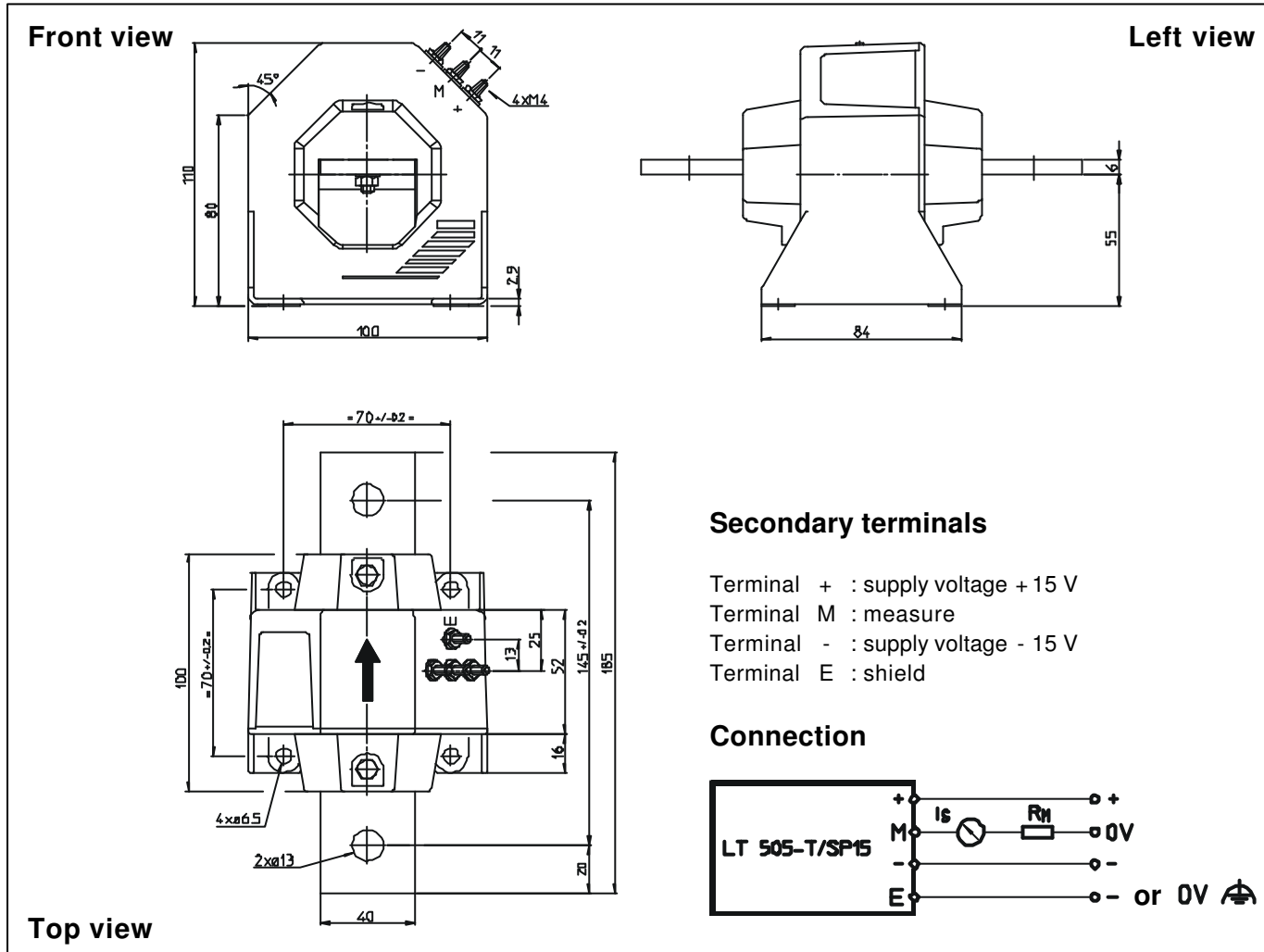

Mechanical characteristics

- | | |
|---------------------------|---|
| • General tolerance | ± 0.5 mm |
| • Fastening | 4 holes $\varnothing 6.5$ mm
or by the primary bar |
| • Primary through-hole | 2 holes $\varnothing 13$ mm |
| • Connection of secondary | M4 threaded studs |
| Fastening torque | 1.2 Nm or .88 Lb - Ft |

Remarks

- I_s is positive when I_p flows in the direction of the arrow.
- Temperature of the primary conductor should not exceed 100°C.