

Current Transducer LT 505-S/SP5

$$I_{PN} = 720 \text{ A}$$

For the electronic measurement of currents : DC, AC, pulsed..., with a galvanic isolation between the primary circuit (high power) and the secondary circuit (electronic circuit).

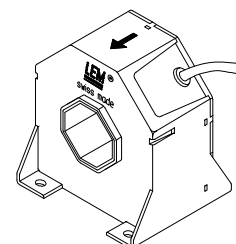

Electrical data

I_{PN}	Primary nominal r.m.s. current	720	A
I_p	Primary current, measuring range	0 .. ± 1400	A
R_M	Measuring resistance with $\pm 24 \text{ V}$	$R_{M \min}$	$R_{M \max}$
		@ $\pm 720 \text{ A}_{\max}$	10 90 Ω
		@ $\pm 1400 \text{ A}_{\max}$	10 23 Ω
I_{SN}	Secondary nominal r.m.s. current	144	mA
K_N	Conversion ratio	1 : 5000	
V_C	Supply voltage ($\pm 5 \%$)	± 24	V
I_C	Current consumption	$30 + I_s$	mA
V_d	R.m.s. voltage for AC isolation test, 50 Hz, 1 mn	6	kV
V_b	R.m.s. rated voltage ¹⁾ , basic isolation	3500	V

Accuracy - Dynamic performance data

X_G	Overall accuracy @ $I_{PN}, T_A = 25^\circ\text{C}$	± 0.5	%
ϵ_L	Linearity error	< 0.1	%
I_O	Offset current @ $I_p = 0, T_A = 25^\circ\text{C}$	Typ	Max
I_{OT}	Thermal drift of I_O		± 0.4 mA
		- 25°C .. + 70°C	± 0.2 ± 0.5 mA
		- 40°C .. + 80°C	± 0.2 ± 1.0 mA
t_r	Response time ²⁾ @ 90 % of I_{PN}	< 1	μs
di/dt	di/dt accurately followed	> 50	A/ μs
f	Frequency bandwidth (- 1 dB)	DC .. 150	kHz

General data

T_A	Ambient operating temperature	- 40 .. + 80	$^\circ\text{C}$
T_S	Ambient storage temperature	- 50 .. + 85	$^\circ\text{C}$
R_S	Secondary coil resistance @ $T_A = 80^\circ\text{C}$	52	Ω
m	Mass	600	g
	Standards	EN 50155 : 1995	

Features

- Closed loop (compensated) current transducer using the Hall effect
- Insulated plastic case recognized according to UL 94-V0.

Special features

- $I_{PN} = 720 \text{ A}$
- $I_p = 0 .. \pm 1400 \text{ A}$
- $V_C = \pm 24 (\pm 5 \%) \text{ V}$
- $T_A = - 40^\circ\text{C} .. + 80^\circ\text{C}$
- Connection to secondary circuit on cable-Thermoflex SIR/XY 3 x 0.5 mm²
- Railway equipment.

Advantages

- Excellent accuracy
- Very good linearity
- Low temperature drift
- Optimized response time
- Wide frequency bandwidth
- No insertion losses
- High immunity to external interference
- Current overload capability.

Applications

- AC variable speed drives and servo motor drives
- Static converters for DC motor drives
- Battery supplied applications
- Uninterruptible Power Supplies (UPS)
- Switched Mode Power Supplies (SMPS)
- Power supplies for welding applications.

Notes : ¹⁾ Pollution class 2. With a non insulated primary bar which fills the through-hole

²⁾ With a di/dt of 100 A/ μs .

Dimensions LT 505-S/SP5 (in mm. 1 mm = 0.0394 inch)

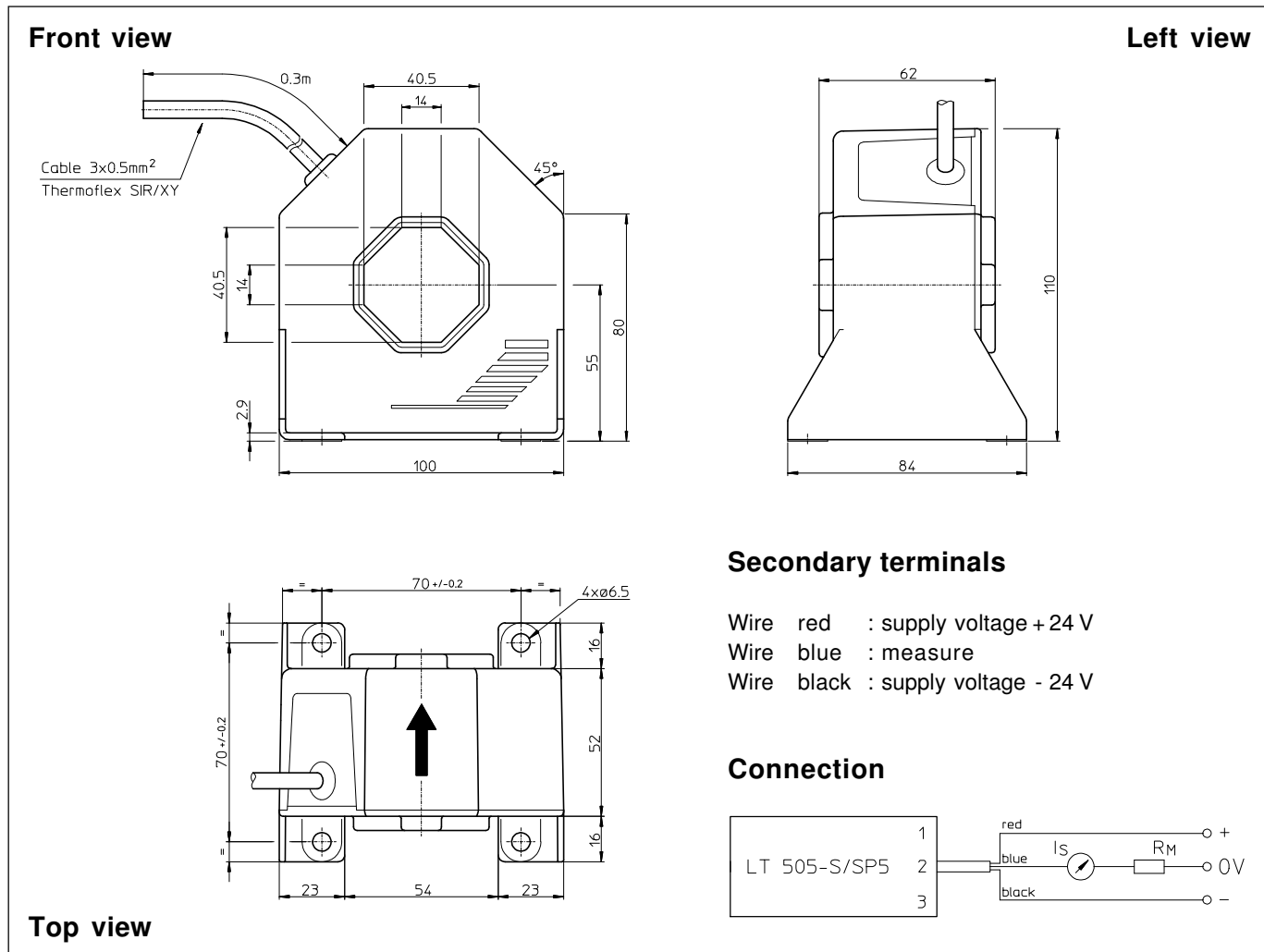

Mechanical characteristics

- General tolerance ± 0.5 mm
- Fastening 4 holes $\varnothing 6.5$ mm
- Primary through-hole 40.5 x 40.5 mm
- Connection of secondary cable-Thermoflex SIR/XY
3 x 0.5 mm²

Remarks

- I_s is positive when I_p flows in the direction of the arrow.
- Temperature of the primary conductor should not exceed 100 °C.
- Dynamic performances (di/dt and response time) are best with a single bar completely filling the primary hole.