

Current Transducer LT 2005-S/SP3

For the electronic measurement of currents : DC, AC, pulsed..., with a galvanic isolation between the primary circuit (high power) and the secondary circuit (electronic circuit).



0648

$$I_{PN} = 1100 \text{ A}$$

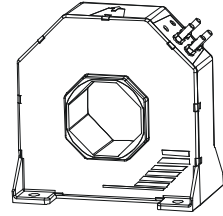

Electrical data

I_{PN}	Primary nominal current rms	1100	A			
I_{PM}	Primary current, measuring range	0 .. ± 2000	A			
R_M	Measuring resistance	$R_{M\text{mini}}$	$R_{M\text{maxi}}$			
		with ± 15 V	@ ± 1100 A _{maxi}	0	35	Ω
			@ ± 2000 A _{maxi}	0	8	Ω
I_{SN}	Secondary nominal current rms	220	mA			
K_N	Conversion ratio	1 : 5000				
V_C	Supply voltage (± 5 %)	± 15	V			
I_C	Current consumption (± 1)	22 + I_S	mA			

Accuracy - Dynamic performance data

X	Accuracy @ I_{PN} , $T_A = 25^\circ\text{C}$	± 0.6	%	
ϵ_L	Linearity error	< 0.1	%	
I_O	Offset current @ $I_p = 0$, $T_A = 25^\circ\text{C}$	Typ	Maxi	
			± 0.8	mA
I_{OM}	Magnetic offset current @ $I_p = 0$ and specified R_M , after an overload of $3 \times I_{PN}$		± 0.4	mA
I_{OT}	Temperature variation of I_O - 30°C .. + 70°C	± 0.2	± 0.5	mA
t_r	Response time ¹⁾ to 90 % of I_{PN} step	< 1		μs
di/dt	di/dt accurately followed	> 50		A/μs
BW	Frequency bandwidth (- 1 dB)	DC .. 100		kHz

General data

T_A	Ambient operating temperature	- 30 .. + 70	°C
T_S	Ambient storage temperature	- 40 .. + 85	°C
R_S	Secondary coil resistance @ $T_A = 70^\circ\text{C}$	25	Ω
m	Mass	1.7	kg
	Standards	EN 50155: 1995	

Features

- Closed loop (compensated) current transducer using the Hall effect
- Isolated plastic case recognized according to UL 94-V0.

Special features

- $I_{PN} = 1100 \text{ A}$
- $I_{PM} = 0 .. \pm 2000 \text{ A}$
- $V_C = \pm 15 (\pm 5 \%) \text{ V}$
- $T_A = - 30^\circ\text{C} .. + 70^\circ\text{C}$
- Shield between primary and secondary
- Hall element located at the bottom center of the transducer core.

Advantages

- Excellent accuracy
- Very good linearity
- Low temperature drift
- Optimized response time
- Wide frequency bandwidth
- No insertion losses
- High immunity to external interference
- Current overload capability.

Applications

- Single or three phases inverter
- Propulsion and braking chopper
- Propulsion converter
- Auxiliary converter
- Battery charger.

Application domain

- Traction.

Note: ¹⁾ With a di/dt of 100 A/μs.

Current Transducer LT 2005-S/SP3

Isolation characteristics

V_d	Rms voltage for AC isolation test, 50 Hz, 1 min	6 ²⁾	kV
		1 ³⁾	kV
		Mini	
dCp	Creepage distance	41	mm
dCl	Clearance distance	41	mm
CTI	Comparative Tracking Index (Group IIIa)	225	

Notes: ²⁾ Between primary and secondary + shield

³⁾ Between shield and secondary.

Safety



This transducer must be used in electric/electronic equipment with respect to applicable standards and safety requirements in accordance with the manufacturer's operating instructions.



Caution, risk of electrical shock

When operating the transducer, certain parts of the module can carry hazardous voltage (eg. primary busbar, power supply).

Ignoring this warning can lead to injury and/or cause serious damage.

This transducer is a built-in device, whose conducting parts must be inaccessible after installation.

A protective housing or additional shield could be used.

Main supply must be able to be disconnected.

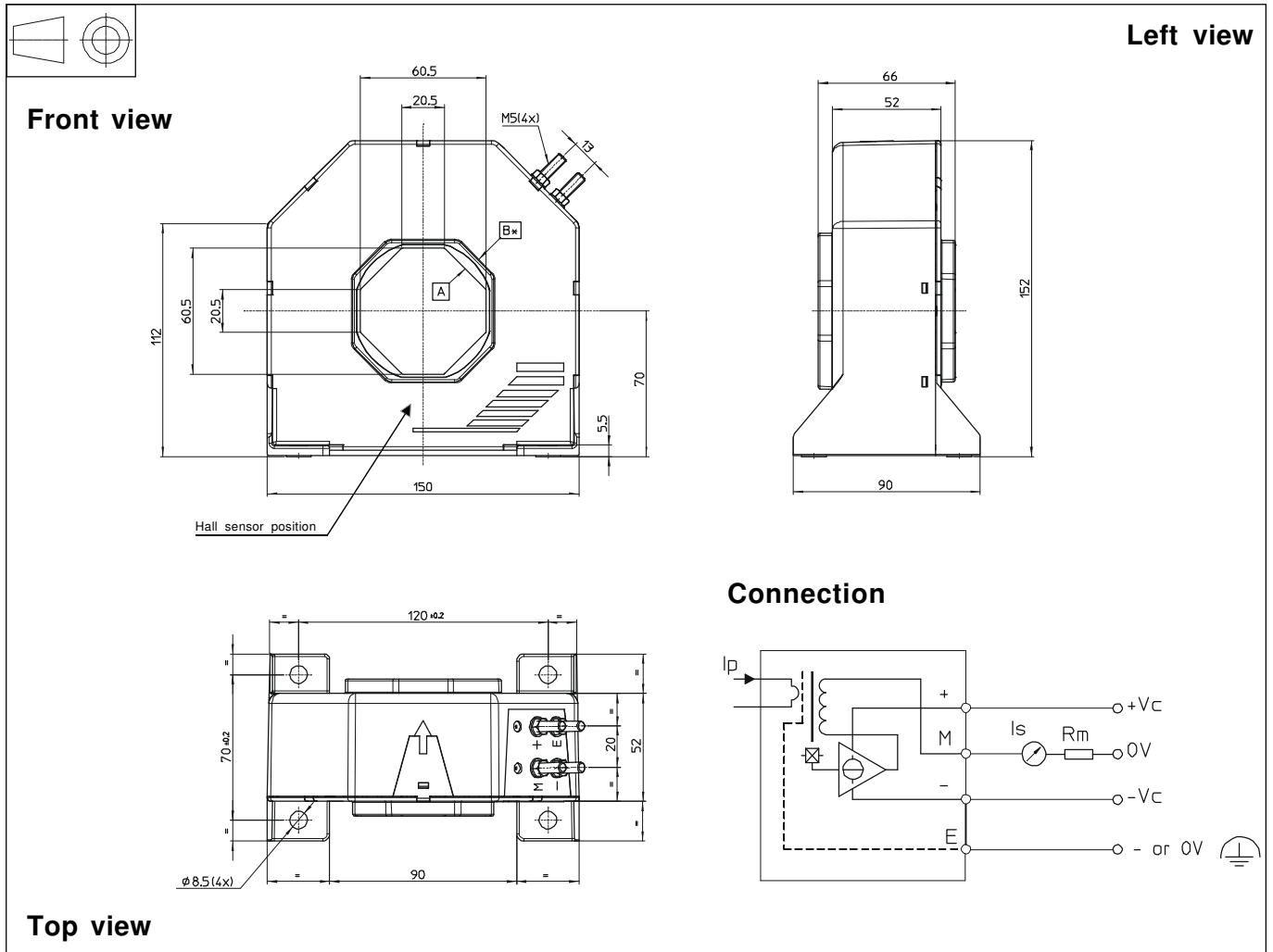
Dimensions LT 2005-S/SP3 (in mm. 1 mm = 0.0394 inch)

Mechanical characteristics

- General tolerance ± 0.5 mm
- Transducer fastening
 - 4 holes $\varnothing 8.5$ mm
 - 4 M8 steel screws
- Recommended fastening torque 10 Nm or 7.38 Lb - Ft
- Octagonal primary through-hole for bar
 - 60.5 x 20.5 mm
 - or \varnothing maxi 56 mm
- Connection of secondary
 - M5 threaded studs
 - Recommended fastening torque 2.2 Nm or 1.62 Lb - Ft

Remarks

- I_s is positive when I_p flows in the direction of the arrow
- Temperature of the primary conductor should not exceed 100 °C
- Dynamic performances (di/dt and response time) are best with a single bar completely filling the primary hole.