

Current Transducer LT 1005-S/SP28

$$I_{PN} = 1000 \text{ A}$$

For the electronic measurement of currents : DC, AC, pulsed..., with a galvanic isolation between the primary circuit (high power) and the secondary circuit (electronic circuit).



16135

Electrical data

I_{PN}	Primary nominal r.m.s. current	1000	A					
I_P	Primary current, measuring range	0 .. ± 2400	A					
R_M	Measuring resistance @	$T_A = 70^\circ\text{C}$	$T_A = 85^\circ\text{C}$	R_{Mmin}	R_{Mmax}			
	with $\pm 15 \text{ V}$	@ $\pm 1300 \text{ A}_{max}$	0	10	@ $\pm 1250 \text{ A}^1$	0	10	Ω
		@ $\pm 1400 \text{ A}_{max}$	0	7	@ $\pm 1450 \text{ A}^1$	0	5	Ω
	with $\pm 24 \text{ V}$	@ $\pm 1500 \text{ A}_{max}$	0	4	@ $\pm 1450 \text{ A}^1$	0	3	Ω
		@ $\pm 2200 \text{ A}_{max}$	0	10	@ $\pm 2100 \text{ A}^1$	3	10	Ω
	@ $\pm 2300 \text{ A}_{max}$	0	7		3	5	Ω	
	@ $\pm 2400 \text{ A}_{max}$	0	5		3	3	Ω	
I_{SN}	Secondary nominal r.m.s. current	200	mA					
K_N	Conversion ratio	1 : 5000						
V_C	Supply voltage ($\pm 5 \%$)	$\pm 15 \dots 24$	V					
I_C	Current consumption	$30 (@ \pm 24 \text{ V}) + I_S$	mA					
V_d	R.m.s. voltage for AC isolation test, 50 Hz, 1 mn	12 ²⁾	kV					
		1.5 ³⁾	kV					
V_e	R.m.s. voltage for partial discharge extinction @ 10 pC	4.1	kV					

Features

- Closed loop (compensated) current transducer using the Hall effect
- Insulated plastic case recognized according to UL 94-V0.

Special features

- $I_P = 0 \dots \pm 2400 \text{ A}$
- $V_C = \pm 15 \dots 24 \text{ V} (\pm 5 \%)$
- $V_d = 12 \text{ kV}$
- $T_A = -40^\circ\text{C} (-50^\circ\text{C}) \dots +85^\circ\text{C}$
- Secondary connection on screened cable $3 \times 0.5 \text{ mm}^2$
- Shield between primary and secondary connected to the cable screening
- Railway equipment
- Customer marking
- Reinforced mounting feet.

Advantages

- Excellent accuracy
- Very good linearity
- Low temperature drift
- Optimized response time
- Wide frequency bandwidth
- No insertion losses
- High immunity to external interference
- Current overload capability.

Applications

- AC variable speed drives and servo motor drives
- Static converters for DC motor drives
- Battery supplied applications
- Uninterruptible Power Supplies (UPS)
- Switched Mode Power Supplies (SMPS)
- Power supplies for welding applications.

Accuracy - Dynamic performance data

X_G	Overall accuracy @ I_{PN} , $T_A = 25^\circ\text{C}$	± 0.5	%
ϵ_L	Linearity error	< 0.1	%
I_O	Offset current @ $I_P = 0$, $T_A = 25^\circ\text{C}$	Typ	Max
			± 0.4 mA
I_{OT}	Thermal drift of I_O	-25 $^\circ\text{C}$.. +70 $^\circ\text{C}$	± 0.2 mA
		-50 $^\circ\text{C}$.. +85 $^\circ\text{C}$	± 0.8 mA
t_r	Response time ⁴⁾ @ 90 % of I_{PN}	< 1	μs
di/dt	di/dt accurately followed	> 50	A/ μs
f	Frequency bandwidth (-1 dB)	DC .. 150	kHz

General data

T_A	Ambient operating temperature	-40 (-50) .. +85 $^\circ\text{C}$	
T_S	Ambient storage temperature	-50 .. +85 $^\circ\text{C}$	
R_S	Secondary coil resistance @	$T_A = 70^\circ\text{C}$	40 Ω
		$T_A = 85^\circ\text{C}$	42 Ω
m	Mass	700	g
	Standards	EN 50155	

Notes : ¹⁾ I_{Pmax} @ +85 $^\circ\text{C}$ & customer measuring resistance. ²⁾ Between primary and secondary + internal shield + screened cable. ³⁾ Between secondary and internal shield + screened cable. ⁴⁾ With a di/dt of 100 A/ μs .

060519/3

Dimensions LT 1005-S/SP28 (in mm. 1 mm = 0.0394 inch)

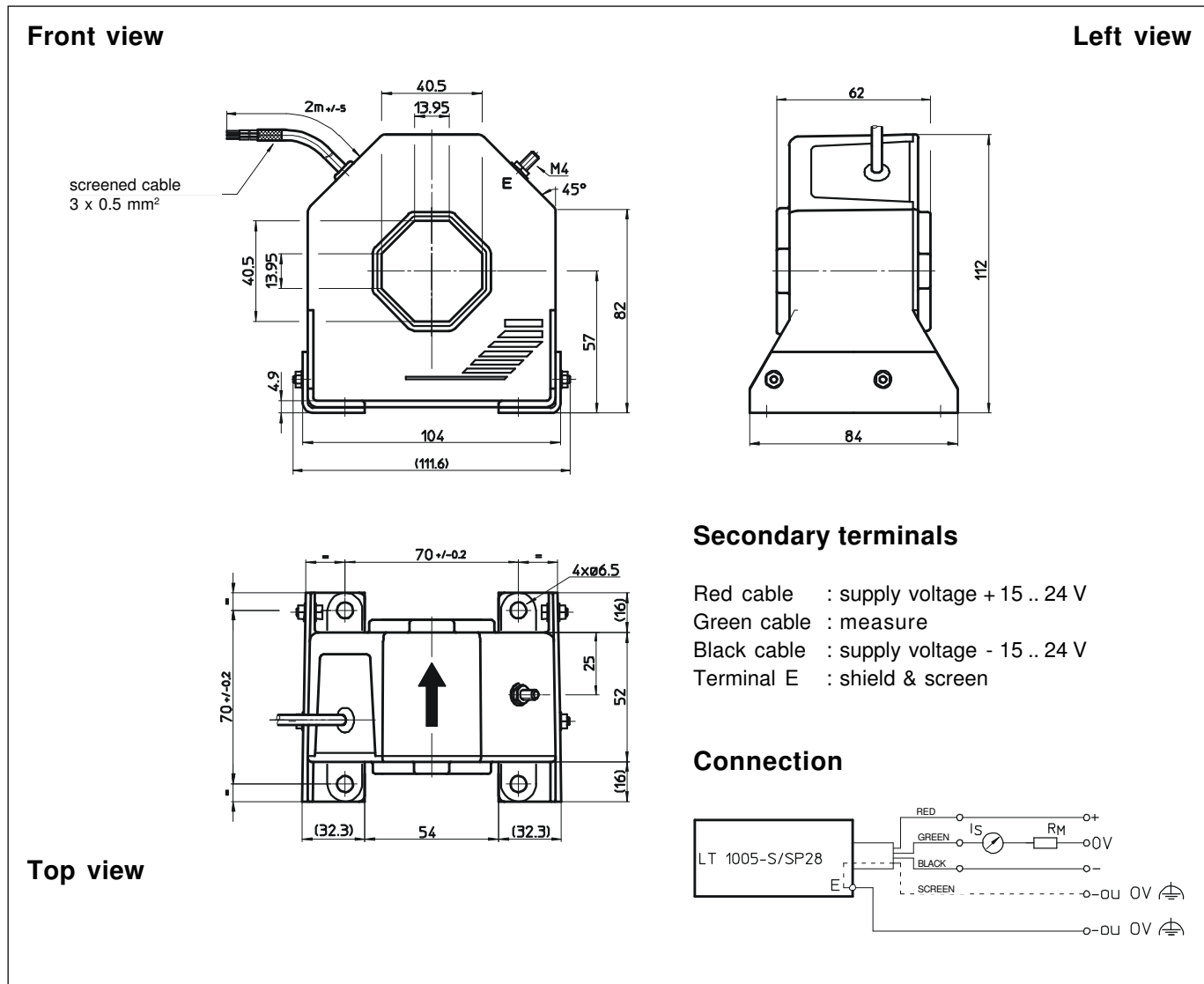

Mechanical characteristics

- General tolerance ± 0.5 mm
- Fastening 4 holes Ø 6.5 mm
- Primary through-hole 40.5 x 40.5 mm
- Connection of secondary screened cable 3 x 0.5 mm²
- Connection to terminal E M4 threaded stud
- Fastening torque 1.2 Nm or .88 Lb. - Ft.

Remarks

- I_s is positive when I_p flows in the direction of the arrow.
- Temperature of the primary conductor should not exceed 100 °C.
- Dynamic performances (di/dt and response time) are best with a single bar completely filling the primary hole.