

Current Transducer LF 505-S/SP22

$$I_{PN} = 500 \text{ A}$$

For the electronic measurement of currents : DC, AC, pulsed..., with a galvanic isolation between the primary circuit (high power) and the secondary circuit (electronic circuit).



16158

Electrical data

I_{PN}	Primary nominal r.m.s. current	500 (630/10 sec.)	A			
I_P	Primary current, measuring range @ $\pm 24 \text{ V}$	0 .. ± 1200	A			
R_M	Measuring resistance	with $\pm 15 \text{ V}$	@ $\pm 500 \text{ A}_{max}$	$R_{M \min}$	$R_{M \max}$	
			@ $\pm 740 \text{ A}_{max}$	0	31	Ω
		with $\pm 24 \text{ V}$	@ $\pm 500 \text{ A}_{max}$	0	3	Ω
			@ $\pm 1000 \text{ A}_{max}$	3	90	Ω
			@ $\pm 1200 \text{ A}_{max}$	3	17	Ω
			3	5	Ω	
I_{SN}	Secondary nominal r.m.s. current	143	mA			
K_N	Conversion ratio	1 : 3500				
V_C	Supply voltage ($\pm 5 \%$) ²⁾	$\pm 15 \dots 24$	V			
I_C	Current consumption	$30 (@ \pm 24 \text{ V}) + I_S$	mA			

Accuracy - Dynamic performance data

X_G	Overall accuracy @ $I_{PN}, T_A = 25^\circ\text{C}$	± 0.6	%
\mathcal{E}_L	Linearity error	< 0.1	%
I_O	Offset current @ $I_P = 0, T_A = 25^\circ\text{C}$	Typ	Max
			± 0.45 mA
I_{OT}	Thermal drift of I_O	-25 °C .. +70 °C	± 0.3 mA
		-40 °C .. +70 °C	± 0.5 mA
t_r	Response time ¹⁾ @ 90 % of I_{PN}	< 1	μs
di/dt	di/dt accurately followed	> 100	A/ μs
f	Frequency bandwidth (-1 dB)	DC .. 100	kHz

General data

T_A	Ambient operating temperature	-40 .. +70	$^\circ\text{C}$
T_S	Ambient storage temperature	-40 .. +85	$^\circ\text{C}$
R_S	Secondary coil resistance @ $T_A = 70^\circ\text{C}$	56	Ω
m	Mass	230	g
	Standards	EN 50155 : 1995	

Notes : ¹⁾ With a di/dt of 100 A/ μs

²⁾ With $V_C = \pm 24 \text{ V} (\pm 3 \%) R_{M \min} = 1.6 \Omega$.

Features

- Closed loop (compensated) current transducer using the Hall effect
- Insulated plastic case recognized according to UL 94-V0.

Special features

- $I_P = 0 \dots \pm 1200 \text{ A}$
- $K_N = 1 : 3500$
- $V_C = \pm 15 \dots 24 (\pm 5 \%) \text{ V}^2)$
- $T_A = -40^\circ\text{C} \dots +70^\circ\text{C}$
- Connection to secondary circuit on M4 threaded studs.

Advantages

- Excellent accuracy
- Very good linearity
- Low temperature drift
- Optimized response time
- Wide frequency bandwidth
- No insertion losses
- High immunity to external interference
- Current overload capability.

Applications

- Single or three phases inverter
- Propulsion and braking chopper
- Propulsion converter
- Auxiliary converter
- Battery charger.

Application Domain

- Traction.

Current Transducer LF 505-S/SP22

Isolation characteristics

V_d	R.m.s. voltage for AC isolation test, 50 Hz, 1 mn	4	kV
		Min	
dCp	Creepage distance ³⁾	29.5	mm
dCl	Clearance distance ³⁾	26.5	mm
CTI	Comparative Tracking Index (Group III a)	175	

Note : ³⁾ Distance between "A" and "B" see outline drawing.

Safety



This transducer must be used in electric/electronic equipment with respect to applicable standards and safety requirements in accordance with the manufacturer's operating instructions.



Caution, risk of electrical shock

When operating the transducer, certain parts of the module can carry hazardous voltage (eg. primary busbar, power supply).

Ignoring this warning can lead to injury and/or cause serious damage.

This transducer is a built-in device, whose conducting parts must be inaccessible after installation.

A protective housing or additional shield could be used.

Main supply must be able to be disconnected.

Dimensions LF 505-S/SP22 (in mm. 1 mm = 0.0394 inch)

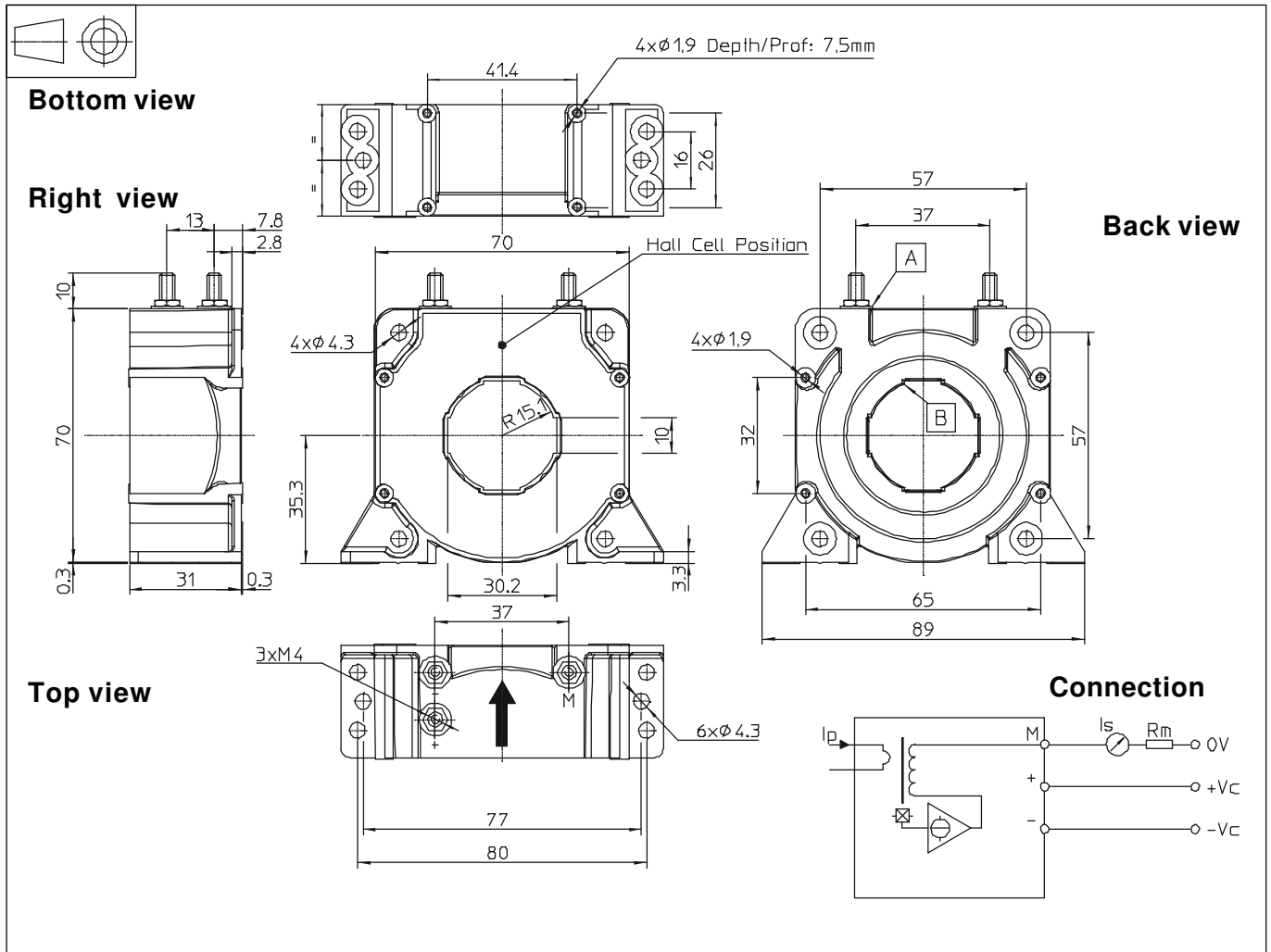

Mechanical characteristics

- General tolerance ± 0.5 mm
- Transducer fastening
 - Vertical or horizontal position 4 or 6 holes $\varnothing 4.3$ mm
 - 4 or 6 M4 steel screws
 - Recommended fastening torque 3.2 Nm or 2.37 Lb. - Ft.
 - or
 - Vertical position 4 holes $\varnothing 1.9$ mm depth: 7.5 mm
 - 4xPT KA25 screws long: 6 mm
 - Recommended fastening torque 0.7 Nm or 0.52 Lb. - Ft.
 - or
 - Horizontal position 4 traversing holes $\varnothing 1.9$ mm
 - 4xPT KA25 screws long: 10 mm
 - Recommended fastening torque 0.75 Nm or 0.55 Lb. - Ft.
- Primary through-hole $\varnothing 30.2$ mm
- Connection of secondary M4 threaded studs
- Recommended fastening torque 1.2 Nm or 0.88 Lb. - Ft.

Remarks

- I_s is positive when I_p flows in the direction of the arrow
- Temperature of the primary conductor should not exceed 100 °C
- Dynamic performances (di/dt and response time) are best with a single bar completely filling the primary hole.