

Current Transducer LF 305-S/SP10

For the electronic measurement of currents: DC, AC, pulsed..., with galvanic isolation between the primary circuit (high power) and the secondary circuit (electronic circuit).



16177

$I_{PN} = 300 \text{ A}$

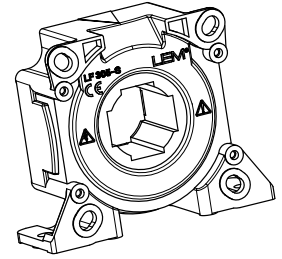

Electrical data

| | | | | | | | |
|----------|----------------------------------|------------------------------------|---------------------|--------------------------|---------------------|----|----------|
| I_{PN} | Primary nominal current rms | 300 | A | | | | |
| I_{PM} | Primary current, measuring range | 0 .. ± 500 | A | | | | |
| R_M | Measuring resistance @ | $T_A = 70^\circ\text{C}$ | | $T_A = 85^\circ\text{C}$ | | | |
| | | $R_{M \text{ min}}$ | $R_{M \text{ max}}$ | $R_{M \text{ min}}$ | $R_{M \text{ max}}$ | | |
| | with $\pm 12 \text{ V}$ | @ $\pm 300 \text{ A}_{\text{max}}$ | 0 | 39 | 0 | 37 | Ω |
| | | @ $\pm 500 \text{ A}_{\text{max}}$ | 0 | 10 | 0 | 8 | Ω |
| | with $\pm 15 \text{ V}$ | @ $\pm 300 \text{ A}_{\text{max}}$ | 0 | 58 | 0 | 56 | Ω |
| | | @ $\pm 500 \text{ A}_{\text{max}}$ | 0 | 21 | 0 | 19 | Ω |
| | with $\pm 20 \text{ V}$ | @ $\pm 300 \text{ A}_{\text{max}}$ | 0 | 90 | 0 | 88 | Ω |
| | | @ $\pm 500 \text{ A}_{\text{max}}$ | 0 | 40 | 0 | 38 | Ω |
| I_{SN} | Secondary nominal current rms | 150 | mA | | | | |
| K_N | Conversion ratio | 1 : 2000 | | | | | |
| V_C | Supply voltage ($\pm 5 \%$) | $\pm 12 \dots 20$ | V | | | | |
| I_C | Current consumption | 16 (@ $\pm 20\text{V}$) + I_S | mA | | | | |

Accuracy - Dynamic performance data

| | | | | | |
|--------------|--|---|------------------|------------|----|
| X_G | Overall accuracy @ I_{PN} , $T_A = 25^\circ\text{C}$ | ± 0.47 | % | | |
| ϵ_L | Linearity error | < 0.1 | % | | |
| I_O | Offset current @ $I_p = 0$, $T_A = 25^\circ\text{C}$ | Typ | Max | | |
| | | | ± 0.2 | mA | |
| I_{OM} | Magnetic offset current ¹⁾ @ $I_p = 0$ and specified R_M , after an overload of $3 \times I_{PN}$ | | ± 0.2 | mA | |
| I_{OT} | Temperature variation of I_O | - $10^\circ\text{C} \dots + 70^\circ\text{C}$ | ± 0.1 | ± 0.30 | mA |
| | | - $40^\circ\text{C} \dots + 85^\circ\text{C}$ | ± 0.2 | ± 0.70 | mA |
| t_{ra} | Reaction time @ 10 % of I_{PN} | < 500 | ns | | |
| t_r | Response time ²⁾ to 90 % of I_{PN} step | < 1 | μs | | |
| di/dt | di/dt accurately followed | > 100 | A/ μs | | |
| BW | Frequency bandwidth (-3 dB) | DC .. 100 | kHz | | |

General data

| | | | |
|-------|--|----------------------------|------------------------------|
| T_A | Ambient operating temperature | - 40 .. + 85 | $^\circ\text{C}$ |
| T_S | Ambient storage temperature | - 40 .. + 85 | $^\circ\text{C}$ |
| R_S | Secondary coil resistance @ $T_A = 70^\circ\text{C}$ | 30 | Ω |
| | | @ $T_A = 85^\circ\text{C}$ | 32 |
| m | Mass | 95 | g |
| | | Standards | EN 50178: 1997 |
| | | | EN 50155: 1995 ³⁾ |

Notes: ¹⁾ The result of the coercive force (Hc) of the magnetic circuit

²⁾ With a di/dt of 100 A/ μs

³⁾ Excepted test according to IEC 61000-4-5.

Features

- Closed loop (compensated) current transducer using the Hall effect
- Isolated plastic case recognized according to UL 94-V0.

Special features

- $T_A = - 40^\circ\text{C} \dots + 85^\circ\text{C}$
- Connection to secondary circuit on Molex Minifit Jr 5566 with gold-plated pins.

Advantages

- Excellent accuracy
- Very good linearity
- Low temperature drift
- Optimized response time
- Wide frequency bandwidth
- No insertion losses
- High immunity to external interference
- Current overload capability.

Applications

- AC variable speed drives and servo motor drives
- Static converters for DC motor drives
- Battery supplied applications
- Uninterruptible Power Supplies (UPS)
- Switched Mode Power Supplies (SMPS)
- Power supplies for welding applications.

Application domains

- Industrial
- Traction.

Current Transducer LF 305-S/SP10

Isolation characteristics

| | | | |
|-------------|--|------|----|
| V_d | Rms voltage for AC isolation test, 50/60 Hz, 1 min | 3 | kV |
| \hat{V}_w | Impulse withstand voltage 1.2/50 μ s | 9.5 | kV |
| | | Min | |
| dCp | Creepage distance | 23.9 | mm |
| dCI | Clearance distance | 10.5 | mm |
| CTI | Comparative Tracking Index (group II) | 175 | |

Applications examples

According to EN 50178 and IEC 61010-1 standards and following conditions:

- Over voltage category OV 3
- Pollution degree PD2
- Non-uniform field

| | EN 50178 | IEC 61010-1 |
|-----------------------|-------------------------|-----------------|
| dCp, dCI, \hat{V}_w | Rated isolation voltage | Nominal voltage |
| Single isolation | 1000 V | 2000 V |
| Reinforced isolation | 690 V | 600 V |

Safety



This transducer must be used in electric/electronic equipment with respect to applicable standards and safety requirements in accordance with the manufacturer's operating instructions.



Caution, risk of electrical shock

When operating the transducer, certain parts of the module can carry hazardous voltage (eg. primary busbar, power supply).

Ignoring this warning can lead to injury and/or cause serious damage.

This transducer is a build-in device, whose conducting parts must be inaccessible after installation.

A protective housing or additional shield could be used.

Main supply must be able to be disconnected.

Dimensions LF 305-S/SP10 (in mm)

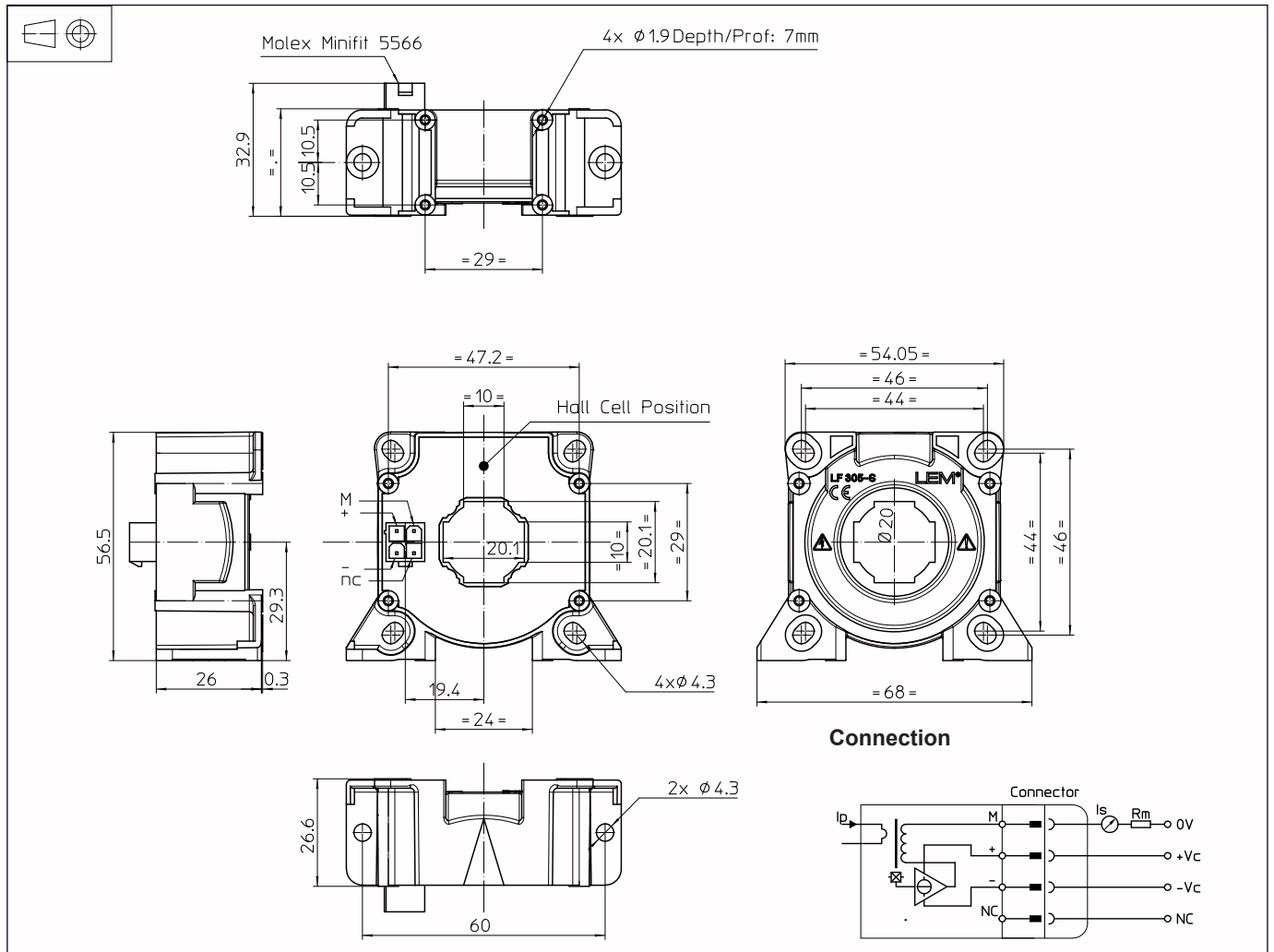

Mechanical characteristics

- General tolerance ± 0.5 mm
- Transducer fastening Vertical position
 - 2 holes $\varnothing 4.3$ mm
 - 2 M4 steel screws
 - Recommended fastening torque 3.2 Nm
 - or
 - 4 holes $\varnothing 1.9$ mm, depth: 7 mm
 - 4 PTKA 25 screws, length: 6 mm
 - Recommended fastening torque 0.7 Nm
- Transducer fastening Horizontal position
 - 4 holes $\varnothing 4.3$ mm
 - 2 M4 steel screws
 - Recommended fastening torque 3.2 Nm
 - or
 - 4 holes $\varnothing 1.9$ mm
 - 4 PTKA 25 screws length: 10 mm
 - Recommended fastening torque 0.75 Nm
- Primary through-hole $\varnothing 20$ mm
- Connection of secondary MOLEX Minifit Jr 5566 gold-plated pins

Remarks

- I_s is positive when I_p flows in the direction of the arrow.
- Temperature of the primary conductor should not exceed 100°C.
- Dynamic performances (di/dt and response time) are best with a single bar completely filling the primary hole.