

# Current Transducer LA 305-T/SP13

$$I_{PN} = 240 \text{ A}$$

For the electronic measurement of currents : DC, AC, pulsed..., with a galvanic isolation between the primary circuit (high power) and the secondary circuit (electronic circuit).



## Electrical data

$I_{PN}$	Primary nominal r.m.s. current	240	A
$I_P$	Primary current, measuring range	0 .. $\pm 800$	A
$R_M$	Measuring resistance	$R_{M \min}$ $R_{M \max}$	
	with $\pm 15 \text{ V}$	3    80	$\Omega$
	@ $\pm 240 \text{ A}_{\max}$ @ $\pm 800 \text{ A}_{\max}$	3    8	$\Omega$
$I_{SN}$	Secondary nominal r.m.s. current	120	mA
$K_N$	Conversion ratio	1 : 2000	
$V_C$	Supply voltage ( $\pm 10 \%$ )	$\pm 15$	V
$I_C$	Current consumption	$20 + I_S$	mA
$V_d$	R.m.s. voltage for AC isolation test, 50 Hz, 1 mn	2.5 <sup>1)</sup>	kV
		1.0 <sup>2)</sup>	kV

## Accuracy - Dynamic performance data

$X_G$	Overall accuracy @ $I_{PN}$ , $T_A = 25^\circ\text{C}$	$\pm 0.9$	%
$\mathcal{E}_L$	Linearity	$< 0.1$	%
$I_O$	Offset current @ $I_P = 0$ , $T_A = 25^\circ\text{C}$	Typ	Max
			$\pm 0.25$ mA
$I_{OM}$	Residual current <sup>3)</sup> @ $I_P = 0$ , after an overload of $3 \times I_{PN}$		$\pm 0.50$ mA
$I_{OT}$	Thermal drift of $I_O$ - $25^\circ\text{C} \dots + 70^\circ\text{C}$	$\pm 0.15$	$\pm 0.45$ mA
$t_{ra}$	Reaction time @ 10 % of $I_{PN}$	$< 500$	ns
$t_r$	Response time <sup>4)</sup> @ 90 % of $I_{PN}$	$< 1$	$\mu\text{s}$
$di/dt$	$di/dt$ accurately followed	$> 100$	A/ $\mu\text{s}$
$f$	Frequency bandwidth (- 3 dB)	DC .. 100	kHz

## General data

$T_A$	Ambient operating temperature	- 25 .. + 70	$^\circ\text{C}$
$T_S$	Ambient storage temperature	- 40 .. + 85	$^\circ\text{C}$
$R_S$	Secondary coil resistance @ $T_A = 70^\circ\text{C}$	23	$\Omega$
$m$	Mass	400	g
	Standards <sup>5)</sup>	EN 50155	

- Notes :**
- 1) Between primary and secondary + shield
  - 2) Between secondary and shield
  - 3) The result of the coercive field of the magnetic circuit
  - 4) With a  $di/dt$  of 100 A/ $\mu\text{s}$
  - 5) A list of corresponding tests is available.

## Features

- Closed loop (compensated) current transducer using the Hall effect
- Insulated plastic case recognized according to UL 94-V0.

## Special features

- $I_{PN} = 240 \text{ A}$
- $I_P = 0 \dots \pm 800 \text{ A}$
- $K_N = 1 : 2000$
- $V_C = \pm 15 (\pm 10 \%) \text{ V}$
- $V_d = 2.5 \text{ kV}$
- $T_A = - 25 \dots + 70^\circ\text{C}$
- Shield between primary and secondary
- Connection to secondary circuit on M4 threaded studs
- Potted
- VRT Burn-in
- Railway equipment.

## Advantages

- Excellent accuracy
- Very good linearity
- Low temperature drift
- Optimized response time
- Wide frequency bandwidth
- No insertion losses
- High immunity to external interference
- Current overload capability.

## Applications

- AC variable speed drives and servo motor drives
- Static converters for DC motor drives
- Battery supplied applications
- Uninterruptible Power Supplies (UPS)
- Switched Mode Power Supplies (SMPS)
- Power supplies for welding applications.

021213/2

## Dimensions LA 305-T/SP13 (in mm. 1 mm = 0.0394 inch)

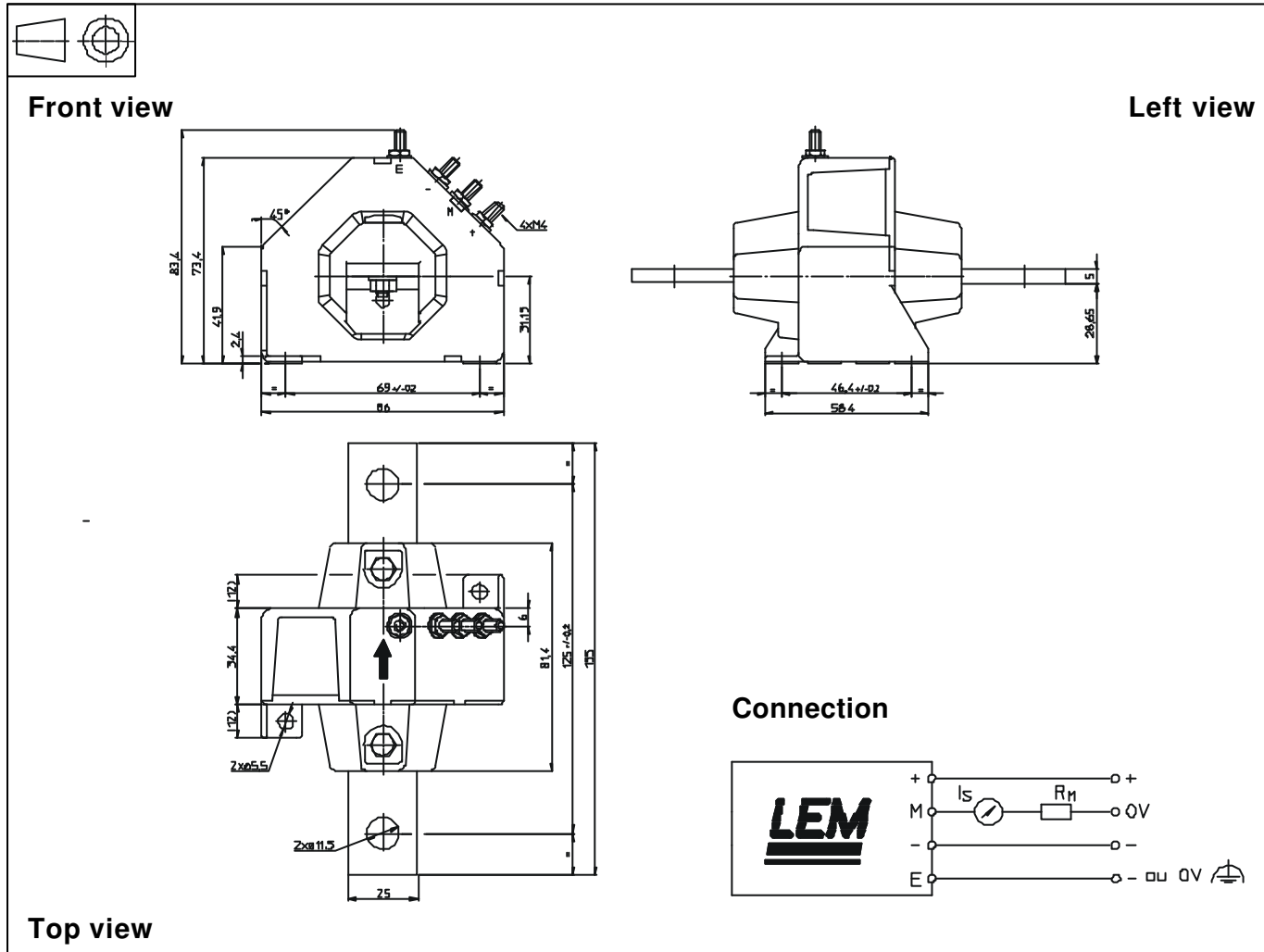

### Mechanical characteristics

- General tolerance  $\pm 0.5$  mm
- Fastening by transducer
  - 2 holes  $\varnothing 5.5$  mm
  - 2 M5 steel screws
  - Fastening torque, max. 4 Nm or 2.95 Lb. - Ft.
- or
- by the primary
  - 2 holes  $\varnothing 11.5$  mm
  - M4 threaded studs
  - Fastening torque 1.2 Nm or .88 Lb - Ft

### Remarks

- $I_s$  is positive when  $I_p$  flows in the direction of the arrow.
- Temperature of the primary conductor should not exceed 100 °C.