

Current Transducer LA 205-T/SP16

$$I_{PN} = 200 \text{ A}$$

For the electronic measurement of currents : DC, AC, pulsed..., with a galvanic isolation between the primary circuit (high power) and the secondary circuit (electronic circuit).



0622

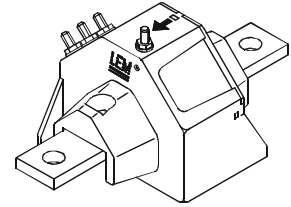

Electrical data

I_{PN}	Primary nominal r.m.s. current	200	A		
I_P	Primary current, measuring range	0 .. ± 400	A		
R_M	Measuring resistance @ $T_A = 70^\circ\text{C}$	$R_{M \min}$	$R_{M \max}$		
				avec $\pm 15 \text{ V}$	@ $\pm 200 \text{ A}_{\max}$
		@ $\pm 400 \text{ A}_{\max}$	0	25 Ω	
		avec $\pm 24 \text{ V}$	@ $\pm 200 \text{ A}_{\max}$	50	240 Ω
@ $\pm 400 \text{ A}_{\max}$	50	80 Ω			
I_{SN}	Secondary nominal r.m.s. current	66.6	mA		
K_N	Conversion ratio	1 : 3000			
V_C	Supply voltage ($\pm 10\%$)	$\pm 15 \dots 24$	V		
I_C	Current consumption	$20 + I_S$	mA		
V_d	R.m.s. voltage for AC isolation test, 50 Hz, 1 mn	6 ¹⁾	kV		
		1 ²⁾	kV		

Accuracy - Dynamic performance data

X_G	Overall accuracy @ $I_{PN}, T_A = 25^\circ\text{C}$	± 0.8	%
\mathcal{E}_L	Linearity	< 0.1	%
I_O	Offset current @ $I_P = 0, T_A = 25^\circ\text{C}$	Typ	Max
			± 0.10 mA
			± 0.30 mA
I_{OM}	Residual current ³⁾ @ $I_P = 0$, after an overload of $3 \times I_{PN}$	± 0.1	± 0.25 mA
I_{OT}	Thermal drift of I_O - $25^\circ\text{C} \dots +75^\circ\text{C}$		
t_{ra}	Reaction time @ 10 % of $I_{P \max}$	< 500	ns
t_r	Response time ⁴⁾ @ 90 % of I_{PN}	< 1	μs
di/dt	di/dt accurately followed	> 100	A/ μs
f	Frequency bandwidth (-3 dB)	DC .. 100	kHz

General data

T_A	Ambient operating temperature	-25 .. +75	$^\circ\text{C}$
T_S	Ambient storage temperature	-40 .. +85	$^\circ\text{C}$
R_S	Secondary coil resistance @ $T_A = 75^\circ\text{C}$	70	Ω
m	Mass	270	g
	Standards	EN 50155	

Features

- Closed loop (compensated) current transducer using the Hall effect
- Insulated plastic case recognized according to UL 94-V0.

Special features

- $I_P = 0 \dots \pm 400 \text{ A}$
- $K_N = 1 : 3000$
- $V_C = \pm 15 \dots 24 (\pm 10\%) \text{ V}$
- $T_A = -25^\circ\text{C} \dots +75^\circ\text{C}$
- Shield between primary and secondary
- Connection to secondary circuit on M4 threaded studs
- Potted
- VRT Burn-in
- Railway equipment.

Advantages

- Excellent accuracy
- Very good linearity
- Low temperature drift
- Optimized response time
- Wide frequency bandwidth
- No insertion losses
- High immunity to external interference
- Current overload capability.

Applications

- AC variable speed drives and servo motor drives
- Static converters for DC motor drives
- Battery supplied applications
- Uninterruptible Power Supplies (UPS)
- Switched Mode Power Supplies (SMPS)
- Power supplies for welding applications.

Notes :
¹⁾ Between primary and secondary + shield
²⁾ Between secondary and shield
³⁾ The result of the coercive field of the magnetic circuit
⁴⁾ With a di/dt of 100 A/ μs .

Dimensions LA 205-T/SP16 (in mm. 1 mm = 0.0394 inch)

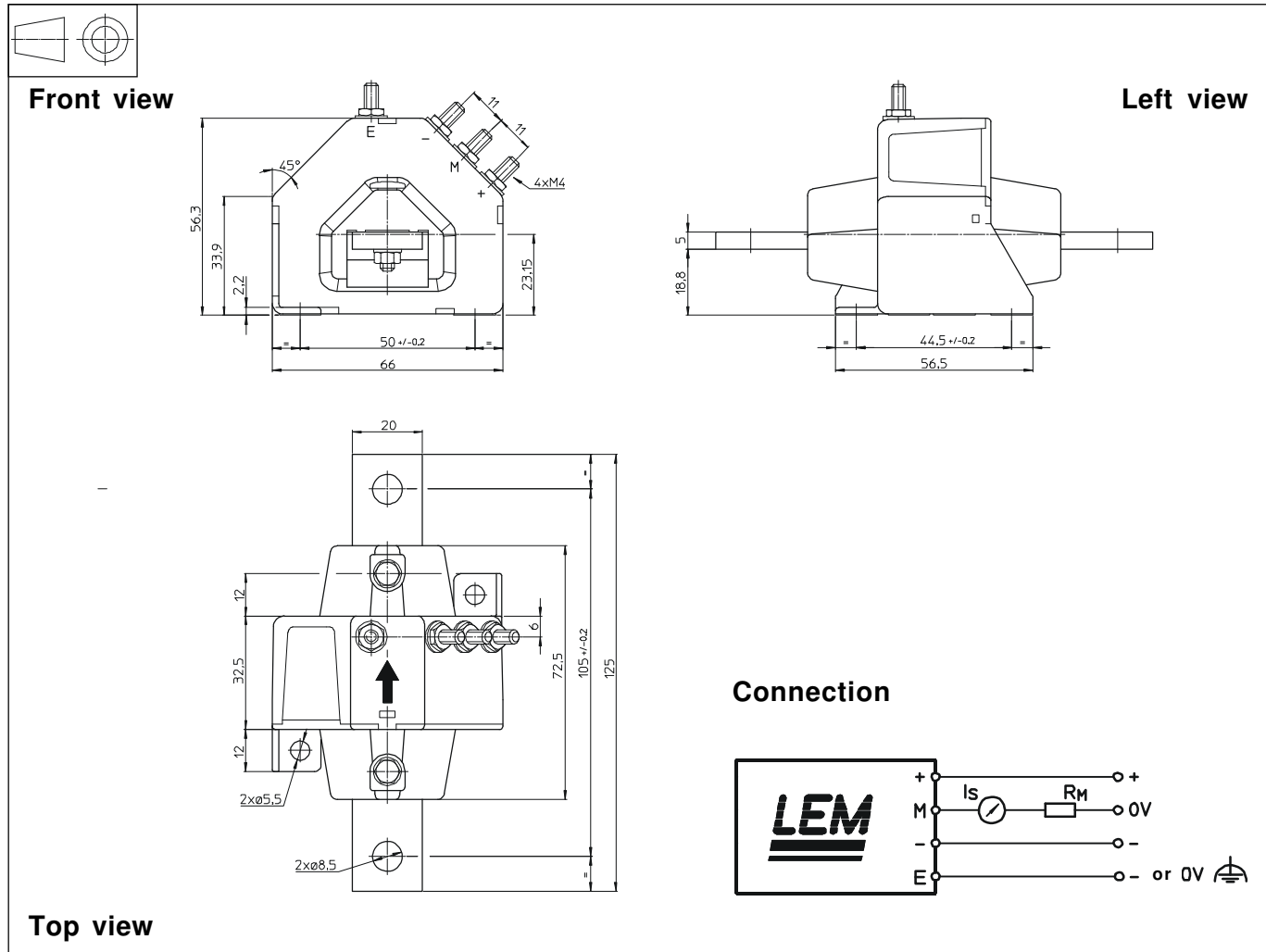

Mechanical characteristics

- General tolerance ± 0.5 mm
- Fastening by transducer
 - 2 holes $\varnothing 5.5$ mm
 - 2 M5 steel screws
 - Fastening torque, max. 4 Nm or 2.95 Lb. - Ft.
 - or
 - by the primary
 - 2 holes $\varnothing 8.5$ mm
 - M4 threaded studs
 - Fastening torque 1.2 Nm or .88 Lb.-Ft.
- Connection of secondary

Remarks

- I_s is positive when I_p flows in the direction of the arrow.
- Temperature of the primary conductor should not exceed 100 °C.