

Voltage Transducer LV 200-AW/2/SP7

$I_{PN} = 20 \text{ mA}$

For the electronic measurement of voltages : DC, AC, pulsed..., with a galvanic isolation between the primary circuit (high voltage) and the secondary circuit (electronic circuit).

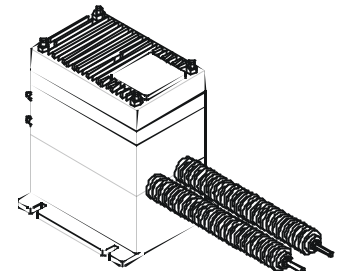

Electrical data

I_{PN}	Primary nominal r.m.s. current	20	m A
I_p	Primary current, measuring range	0 .. ± 40	m A
R_M	Measuring resistance	$R_{M \min}$	$R_{M \max}$
		@ $\pm 20 \text{ mA}_{\max}$	0 93 Ω
		@ $\pm 40 \text{ mA}_{\max}$	0 31 Ω
I_{SN}	Secondary nominal r.m.s. current	100	m A
K_N	Conversion ratio	10000 : 2000	
V_C	Supply voltage ($\pm 10 \%$)	$\pm 17 \dots 28$	V
I_C	Current consumption	$90(@\pm 28V) + I_S$	m A
V_d	R.m.s. voltage for AC isolation test, 50 Hz, 1 mn	28 ¹⁾	k V
		2 ²⁾	k V

Accuracy - Dynamic performance data

X_G	Overall Accuracy @ $I_{PN}, T_A = 25^\circ\text{C}$	± 0.5	%
ϵ_L	Linearity	< 0.1	%
I_O	Offset current @ $I_p = 0, T_A = 25^\circ\text{C}$	Typ	Max
			± 0.3 m A
I_{OT}	Thermal drift of I_O - 25°C .. + 70°C	± 0.4	± 0.7 m A
t_r	Response time ³⁾ @ 90 % of V_{PN}	20 .. 100	μs

General data

T_A	Ambient operating temperature	- 25 .. + 70	$^\circ\text{C}$
T_S	Ambient storage temperature	- 40 .. + 85	$^\circ\text{C}$
R_p	Primary coil resistance @ $T_A = 25^\circ\text{C}$	550	Ω
R_S	Secondary coil resistance @ $T_A = 70^\circ\text{C}$	40	Ω
m	Mass	3	kg
	Standards ⁴⁾	EN 50178(01.10.97)	

Features

- Closed loop (compensated) voltage transducer using the Hall effect
- Insulated plastic case recognized according to UL 94-V0
- Accessible electronic circuit
- Shield between primary and secondary circuit.

Principle of use

- For voltage measurements, a current proportional to the measured voltage must be passed through an external resistor R_1 which is selected by the user and installed in series with the primary circuit of the transducer.

Special Features

- $I_p = 0 \dots \pm 40 \text{ mA}$
- $V_d = 28 \text{ kV}^{1)}$.

Advantages

- Excellent accuracy
- Very good linearity
- Low thermal drift
- High immunity to external interference

Applications

- AC variable speed drives and servo motor drives
- Static converters for DC motor drives
- Battery supplied applications
- Uninterruptible Power Supplies (UPS)
- Power supplies for welding applications.

Notes :
¹⁾ Between primary and secondary + shield
²⁾ Between secondary and shield
³⁾ $R_1 = 50 \text{ k}\Omega$ (L/R constant, produced by the resistance and inductance of the primary circuit)
⁴⁾ A list of corresponding tests is available.

Dimensions LV 200-AW/2/SP7 (in mm. 1 mm = 0.0394 inch)

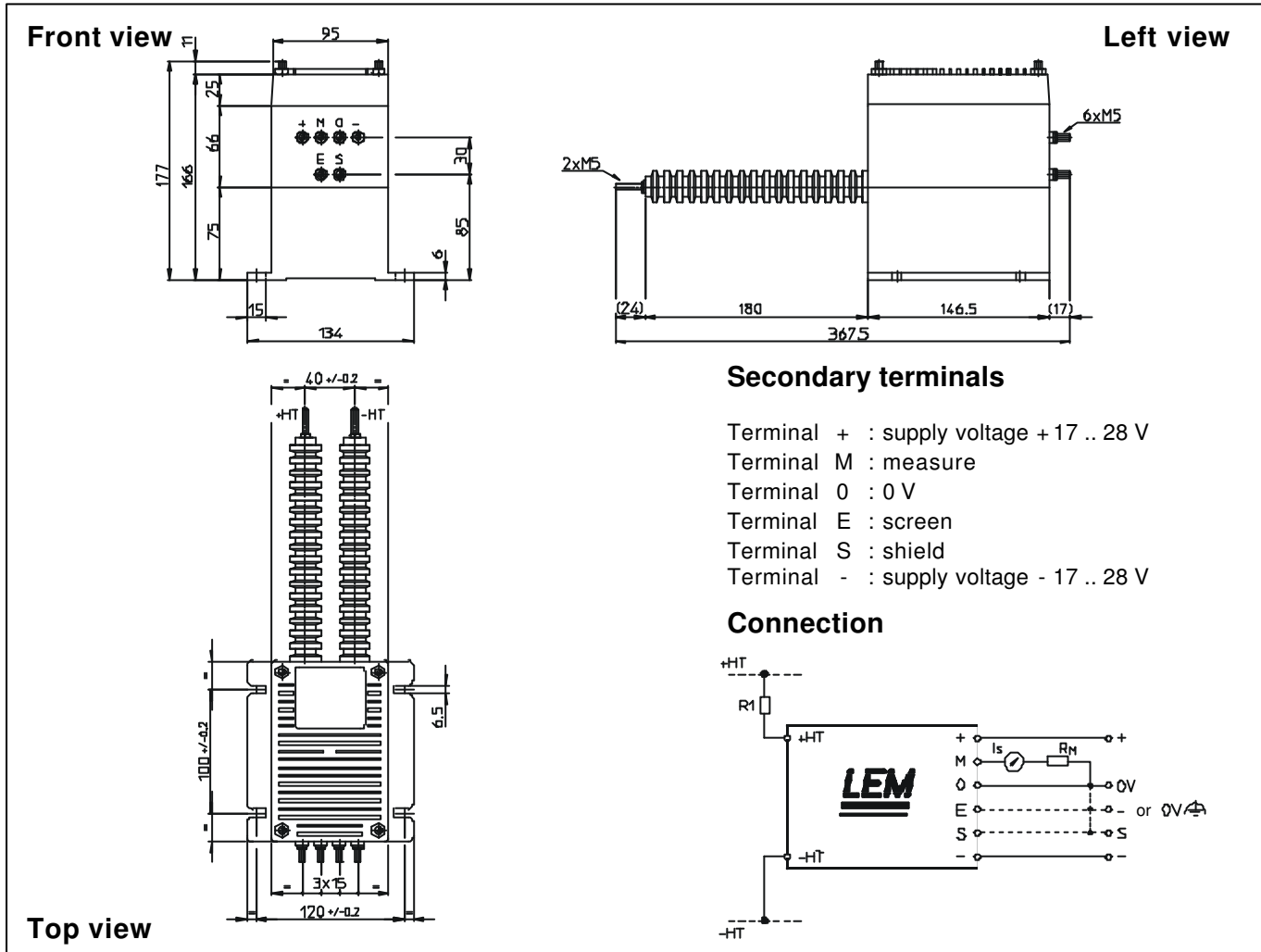

Mechanical characteristics

- General tolerance ± 0.5 mm
- Transducer fastening 4 slots $\varnothing 6.5$ mm
4 M6 steel screws
Recommended fastening torque 4.5 Nm or 3.32 Lb - Ft.
- Connection of primary M5 threaded studs
- Connection of secondary M5 threaded studs
- Recommended fastening torque 2.2 Nm or 1.62 Lb - Ft.

Remarks

- I_s is positive when V_p is applied on terminal +HT.
- The shield (terminal E) and the screen (terminal S) must be connected to 0 V or terminal -.

Instructions for use of the voltage transducer model LV 200-AW/2/SP7

Primary resistor R_1 : the transducer's optimum accuracy is obtained at the nominal primary current. As far as possible, R_1 should be calculated so that the nominal voltage to be measured corresponds to a primary current of 20 mA .

Example: Voltage to be measured $V_{PN} = 1000$ V

- a) $R_1 = 50$ k Ω /40 W, $I_p = 20$ mA Accuracy = ± 0.5 % of V_{PN} (@ $T_A = +25^\circ\text{C}$)
 b) $R_1 = 200$ k Ω /10 W, $I_p = 5$ mA Accuracy = ± 2.0 % of V_{PN} (@ $T_A = +25^\circ\text{C}$)

Operating range (recommended) : taking into account the resistance of the primary windings (which must remain low compared to R_1 , in order to keep thermal deviation as low as possible) and the isolation, this transducer is suitable for measuring nominal voltages from 100 to 2500 V.